

FARPOINTE
P-900 HA

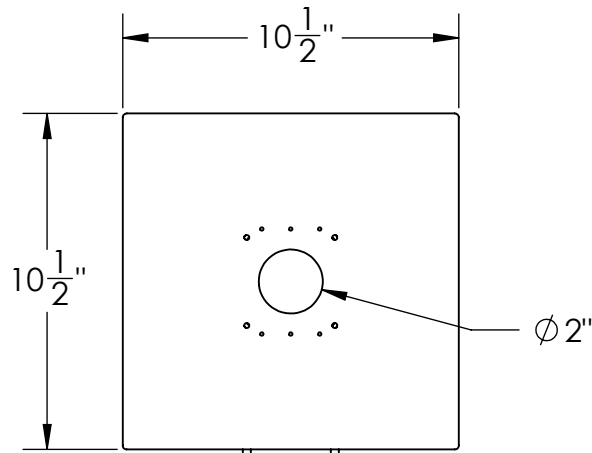

DETAIL A

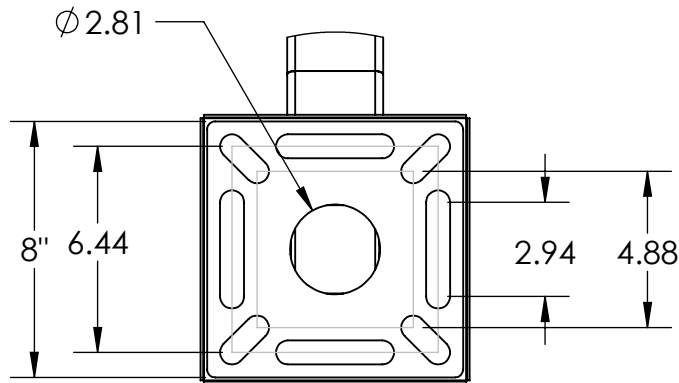
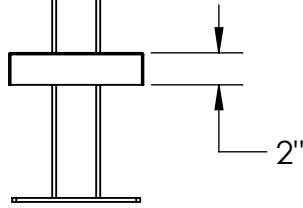
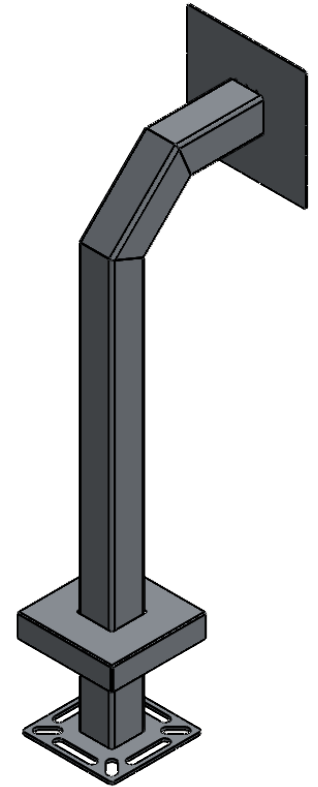
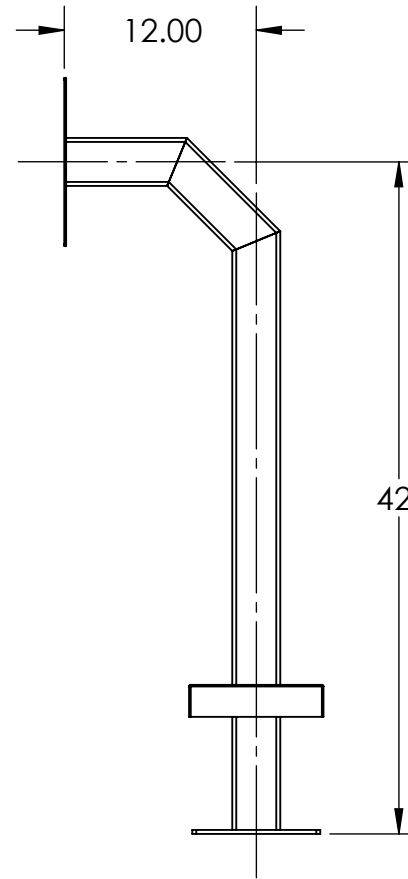

DETAIL B

NOTES:

- 1/2" Ø MOUNTING HARDWARE IS RECOMMENDED FOR 5X5 BASEPLATE MODELS. L-BOLT-500, STUD-ANCHOR-500.
- 5/8" Ø MOUNTING HARDWARE IS RECOMMENDED FOR 8X8 AND 12X12 BASEPLATE MODELS. L-BOLT-625, STUD-ANCHOR-625
- MATERIAL OF CONSTRUCTION IS 304SS, BRUSHED #4 FINISH.



PEDESTALPRO.COM
1-800-660-3072

UNLESS OTHERWISE SPECIFIED:

DIMENSIONS ARE IN INCHES
TOLERANCES:
FRACTIONAL: ± 1/32
ANGULAR: ± 2°
TWO PLACE DECIMAL ± 0.010
THREE PLACE DECIMAL ± 0.005

INTERPRET GEOMETRIC
TOLERANCING PER:
ASME Y14.5 -2009

NAME DATE

DRAWN

CHECKED

PROPRIETARY AND CONFIDENTIAL

THE INFORMATION CONTAINED IN THIS
DRAWING IS THE SOLE PROPERTY OF
PEDESTALPRO LLC. ANY REPRODUCTION
IN PART OR AS A WHOLE WITHOUT THE
WRITTEN PERMISSION OF PEDESTALPRO LLC
IS PROHIBITED.

TITLE:

INSTALLATION

Thursday, October 25,
2018 3:57:46 PM

WEIGHT:

SIZE
A

PART NO.
33PE1-FARP-01-304

REV
B

NO SCALE

SHEET 1 OF 4

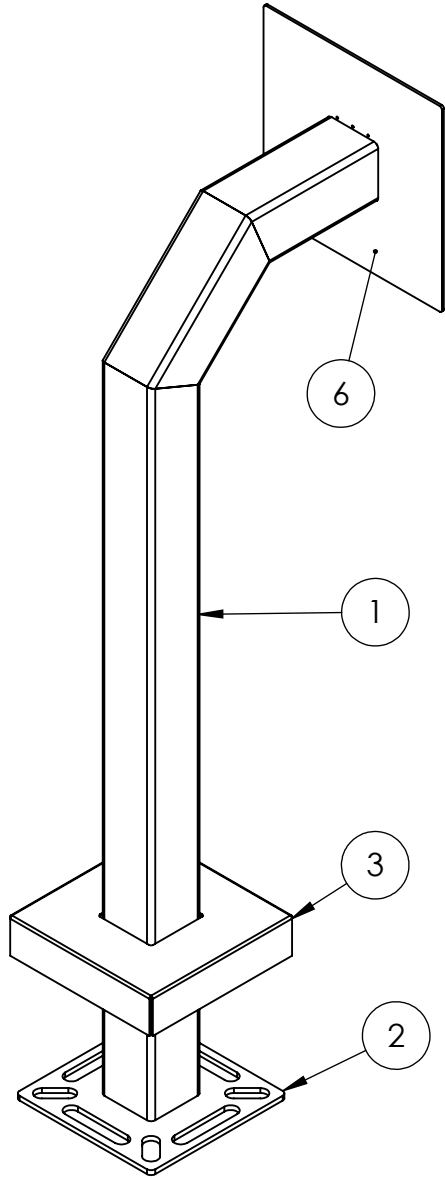

ITEM NO.	PART NUMBER	DESCRIPTION	QTY.
1	33PE1-FARP-01-CRS	3X3X.120 SQ SS TUBE	1
2	PLTBAS-8-3	8" STANDARD BASE PLATE	1
3	PLTCOV-10-6	8" STANDARD COVER PLATE	1
4	--	1/4-20 X .50 ZINC PL CARRIAGE BOLT	4
5	--	1/4-20 ZINC PL HEX NUT	4
6	PLTFAC 10-10	DEVICE MOUNTING PLATE	1

NOTES:

1. BUTT WELDED SECTIONS ARE NOT ALLOWED, EACH SECTION OF TUBE MUST BE FROM CONTINUOUS STOCK.
2. ALL WELDS ARE TO BE CONTINUOUS FILLET WELDS UNLESS NOTED OTHERWISE.
3. SEE STANDARD PREPARATION AND COATING INSTRUCTIONS FOR COATING PROCEDURE AND COLOR.
4. FASTENERS ARE TO BE BAGGED AND SHIPPED WITH PEDESTAL.
5. SEE STANDARD PACKAGING INSTRUCTIONS FOR PACKAGING PROCEDURE.



PEDESTALPRO.COM
1-800-660-3072

UNLESS OTHERWISE SPECIFIED:

DIMENSIONS ARE IN INCHES
TOLERANCES:
FRACTIONAL: $\pm 1/32$
ANGULAR: $\pm 2^\circ$
TWO PLACE DECIMAL: ± 0.010
THREE PLACE DECIMAL: ± 0.005

INTERPRET GEOMETRIC
TOLERANCING PER:
ASME Y14.5 -2009

NAME	DATE
DRAWN	
CHECKED	

PROPRIETARY AND CONFIDENTIAL

THE INFORMATION CONTAINED IN THIS DRAWING IS THE SOLE PROPERTY OF PEDESTALPRO LLC. ANY REPRODUCTION IN PART OR AS A WHOLE WITHOUT THE WRITTEN PERMISSION OF PEDESTALPRO LLC IS PROHIBITED.

TITLE:
ASSEMBLY

Thursday, October 25,
2018 3:57:46 PM

WEIGHT:

SIZE A	PART NO. 33PE1-FARP-01-304
------------------	-------------------------------

REV B

NO SCALE

SHEET 2 OF 4