

NOTES:
 1. MATERIAL OF CONSTRUCTION IS 304 SS, BRUSHED #4.



PEDESTALPRO.COM
 1-800-660-3072

UNLESS OTHERWISE SPECIFIED:
 DIMENSIONS ARE IN INCHES
 TOLERANCES:
 FRACTIONAL ± 1/32
 ANGULAR: ± 2°
 TWO PLACE DECIMAL ± 0.010
 THREE PLACE DECIMAL ± 0.005
 INTERPRET GEOMETRIC
 TOLERANCING PER:
 ASME Y14.5 -2009

NAME	DATE
DRAWN	
CHECKED	
PROPRIETARY AND CONFIDENTIAL	
THE INFORMATION CONTAINED IN THIS DRAWING IS THE SOLE PROPERTY OF PEDESTALPRO LLC. ANY REPRODUCTION IN PART OR AS A WHOLE WITHOUT THE WRITTEN PERMISSION OF PEDESTALPRO LLC IS PROHIBITED.	

TITLE: INSTALLATION		SIZE A	PART NO. 64TOW-2NIP-01-304	REV B
Tuesday, October 23, 2018 1:52:42 PM		NO SCALE		SHEET 1 OF 7
WEIGHT:				

ITEM NO.	PART NUMBER	DESCRIPTION	QTY.
1	PLTCAP-46-46-30	CAP PLATE	1
2	64TOW-2NIP-01-304 TUBE	VERTICAL TUBE	1
3	PLTBAS-46-46	BASE PLATE	1
4	PLTACC-510	ACCESS PANEL	1
5	--	8-32 SS BUTTON HEAD SCREW	4

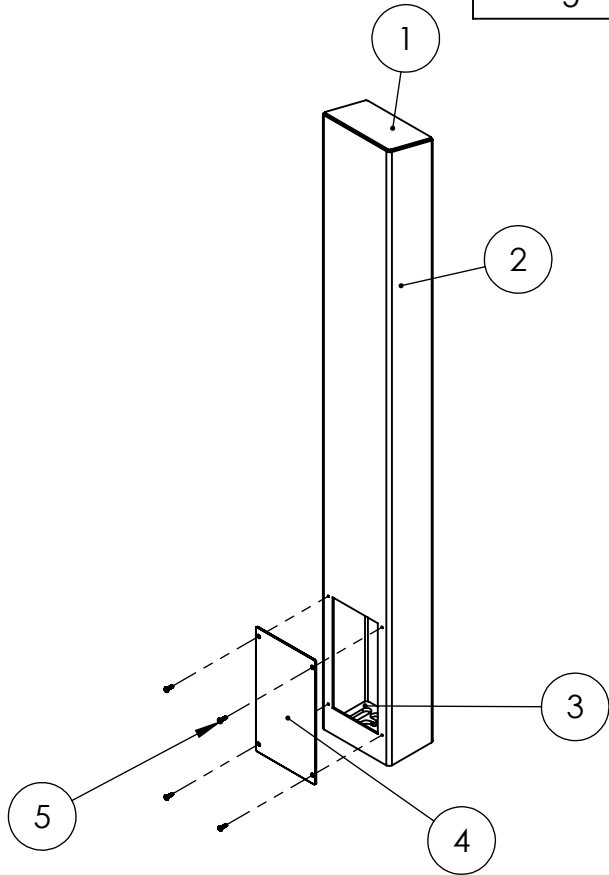

NOTES:

1. SEE STANDARD PREPARATION AND COATING INSTRUCTIONS FOR COATING PROCEDURE AND COLOR
2. SEE STANDARD PACKAGING INSTRUCTIONS FOR PACKAGING PROCEDURE



PEDESTALPRO.COM
1-800-660-3072

UNLESS OTHERWISE SPECIFIED:

DIMENSIONS ARE IN INCHES
TOLERANCES:
FRACTIONAL $\pm 1/32$
ANGULAR: $\pm 2^\circ$
TWO PLACE DECIMAL ± 0.010
THREE PLACE DECIMAL ± 0.005

INTERPRET GEOMETRIC
TOLERANCING PER:
ASME Y14.5 -2009

NAME	DATE
DRAWN	
CHECKED	

PROPRIETARY AND CONFIDENTIAL
THE INFORMATION CONTAINED IN THIS DRAWING IS THE SOLE PROPERTY OF PEDESTALPRO LLC. ANY REPRODUCTION IN PART OR AS A WHOLE WITHOUT THE WRITTEN PERMISSION OF PEDESTALPRO LLC IS PROHIBITED.

TITLE:
ASSEMBLY

Tuesday, October 23,
2018 1:52:42 PM

WEIGHT:

SIZE	PART NO.	REV
A	64TOW-2NIP-01-304	B
NO SCALE		SHEET 2 OF 7