

OPENPATH TRUTH

NOTES:

1. MATERIAL OF CONSTRUCTION IS 304 SS, BRUSHED #4.

UNLESS OTHERWISE SPECIFIED:

DIMENSIONS ARE IN INCHES
 TOLERANCES:
 FRACTIONAL $\pm 1/32$
 ANGULAR: $\pm 2^\circ$
 TWO PLACE DECIMAL ± 0.010
 THREE PLACE DECIMAL ± 0.005

INTERPRET GEOMETRIC
 TOLERANCING PER:
 ASME Y14.5 -2009

NAME DATE

DRAWN

CHECKED

PROPRIETARY AND CONFIDENTIAL

THE INFORMATION CONTAINED IN THIS
 DRAWING IS THE SOLE PROPERTY OF
 PEDESTALPRO LLC. ANY REPRODUCTION
 IN PART OR AS A WHOLE WITHOUT THE
 WRITTEN PERMISSION OF PEDESTALPRO LLC
 IS PROHIBITED.

TITLE:

INSTALLATION

Monday, May 24, 2021
 2:22:39 PM

WEIGHT: 6.191

SIZE
A

PART NO.
 610HOU-OPEN-01-304

REV
0

NO SCALE

SHEET 1 OF 6

ITEM NO.	PART NUMBER	DESCRIPTION	QTY.
1	610HOU-OPEN-01-304 ENCLOSURE	ENCLOSURE WELDMENT	1
2	HINGE	PIANO HINGE	1
3	610HOU-OPEN-01-304 DOOR	DOOR WELDMENT	1
4	GASKET SIDE	3/8" X .150 WEATHERSTRIPPING	2
5	GASKET TOP	3/8" X .150 WEATHERSTRIPPING	1
6	--	6-32 PAN HEAD SCREW	2
7	--	6-32 EXTERNAL TOOTH LOCK NUT	2
8	610HOU-OPEN-01-304 BRACKET	DEVICE BRACKET	1
9	--	8-32 SS TORX SECURITY SCREW	1
11	--	8-32 X 1/2 SS PEM STUD	4
12	--	8-32 SS NYLON LOCK NUT	4

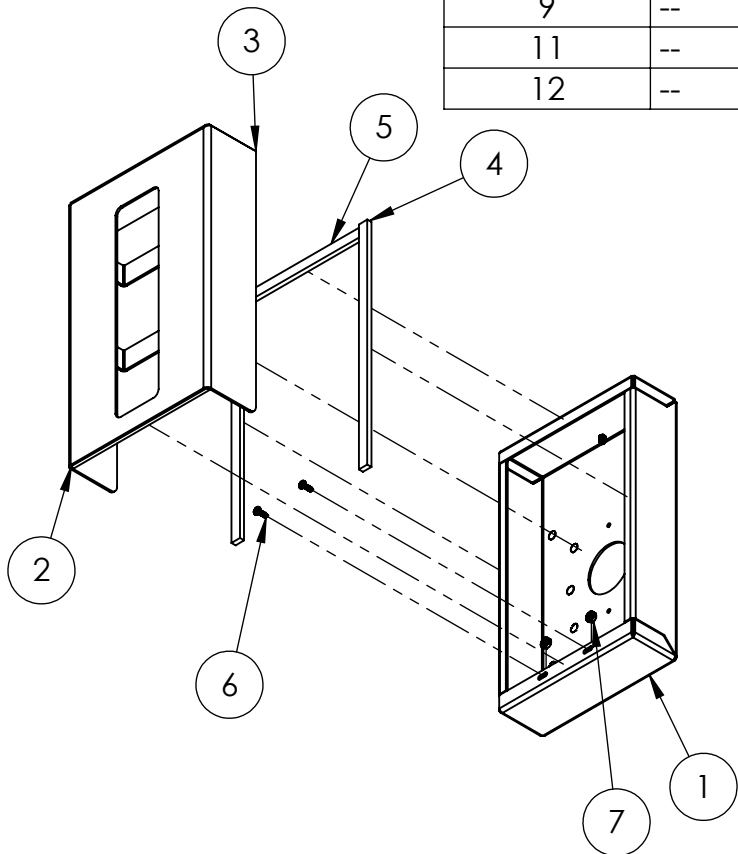

NOTES:

- SEE STANDARD PREPARATION AND COATING INSTRUCTIONS FOR COATING PROCEDURE AND COLOR.
- SEE STANDARD PACKAGING INSTRUCTIONS FOR PACKAGING PROCEDURE.

UNLESS OTHERWISE SPECIFIED:

DIMENSIONS ARE IN INCHES
 TOLERANCES:
 FRACTIONAL ± 1/32
 ANGULAR: ± 2°
 TWO PLACE DECIMAL ± 0.010
 THREE PLACE DECIMAL ± 0.005

INTERPRET GEOMETRIC
 TOLERANCING PER:
 ASME Y14.5 -2009

NAME DATE

DRAWN

CHECKED

PROPRIETARY AND CONFIDENTIAL

THE INFORMATION CONTAINED IN THIS
 DRAWING IS THE SOLE PROPERTY OF
 PEDESTALPRO LLC. ANY REPRODUCTION
 IN PART OR AS A WHOLE WITHOUT THE
 WRITTEN PERMISSION OF PEDESTALPRO LLC
 IS PROHIBITED.

TITLE:

ASSEMBLY

Tuesday, August 4,
 2020 1:54:51 PM

WEIGHT: 6.191

SIZE
A

PART NO.
 610HOU-OPEN-01-304

REV
0

NO SCALE

SHEET 2 OF 6

PEDESTALPRO.COM
 1-800-660-3072