

SECTION A-A

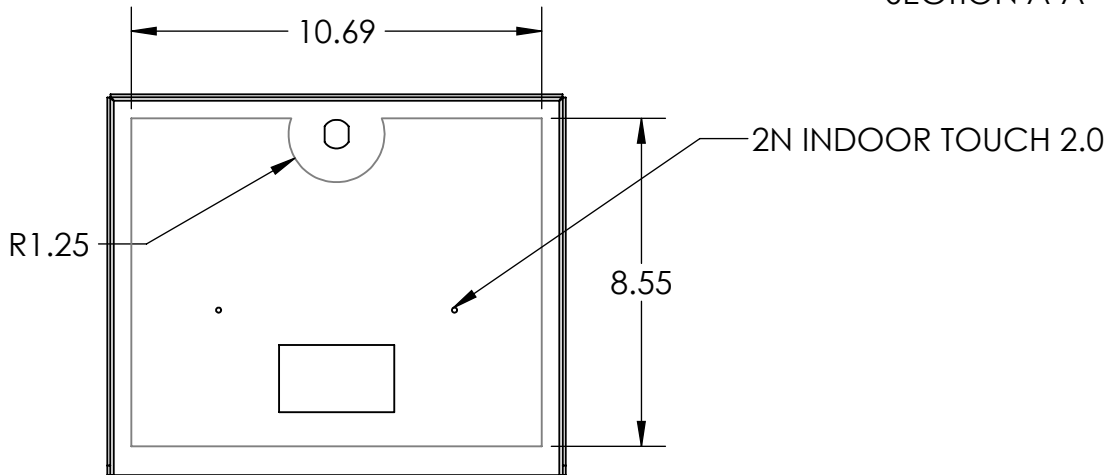
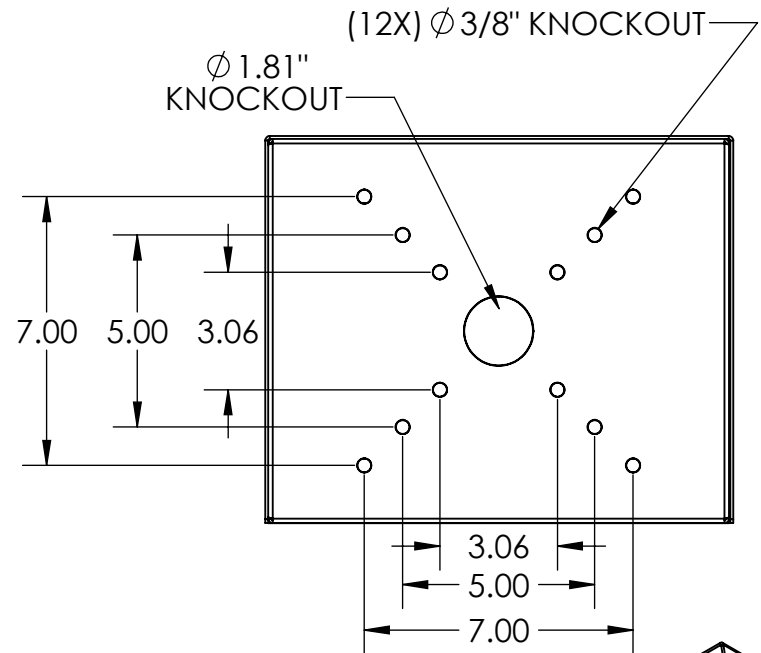

AVAILABLE CUTOUT AREA

NOTES:

1. MATERIAL OF CONSTRUCTION IS 304 SS, BRUSHED #4.

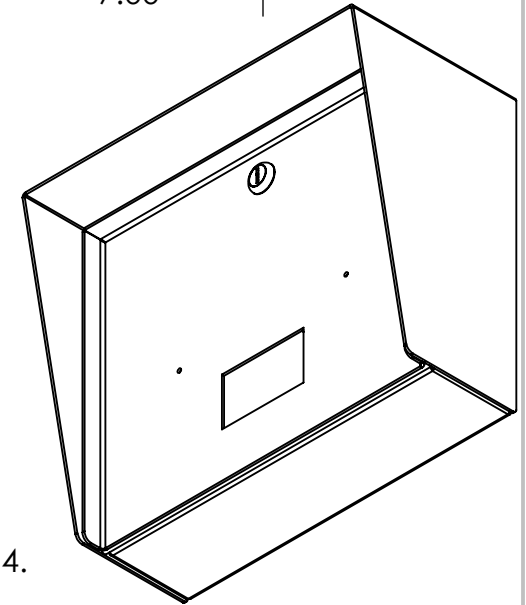

PEDESTALPRO.COM
1-800-660-3072

UNLESS OTHERWISE SPECIFIED:

DIMENSIONS ARE IN INCHES
TOLERANCES:
FRACTIONAL $\pm 1/32$
ANGULAR: $\pm 2^\circ$
TWO PLACE DECIMAL ± 0.010
THREE PLACE DECIMAL ± 0.005

INTERPRET GEOMETRIC
TOLERANCING PER:
ASME Y14.5 -2009

NAME	DATE
DRAWN	
CHECKED	

PROPRIETARY AND CONFIDENTIAL
THE INFORMATION CONTAINED IN THIS DRAWING IS THE SOLE PROPERTY OF PEDESTALPRO LLC. ANY REPRODUCTION IN PART OR AS A WHOLE WITHOUT THE WRITTEN PERMISSION OF PEDESTALPRO LLC IS PROHIBITED.

TITLE:
INSTALLATION

Friday, April 21, 2023
10:46:52 AM

WEIGHT: 13.212

SIZE	PART NO.	REV
A	1210HOU-2NIP-01-304	A
NO SCALE		SHEET 1 OF 6

ITEM NO.	PART NUMBER	DESCRIPTION	QTY.
1	1210HOU-2NIP-01-304 ENCLOSURE	ENCLOSURE WELDMENT	1
2	1210HOU-2NIP-01-304 DOOR	DOOR WELDMENT	1
3	1210HOU-2NIP-01-304 HOOD	HOOD	1
4	HINGE	PIANO HINGE	1
5	CAM LOCK	STRAIGHT CAM	1
6	GASKET SIDE	3/8" X .150 WEATHERSTRIPPING	2
7	GASKET TOP	3/8" X .150 WEATHERSTRIPPING	1
8	--	6-32 PAN HEAD SCREW	4
9	--	6-32 EXTERNAL TOOTH LOCK NUT	4

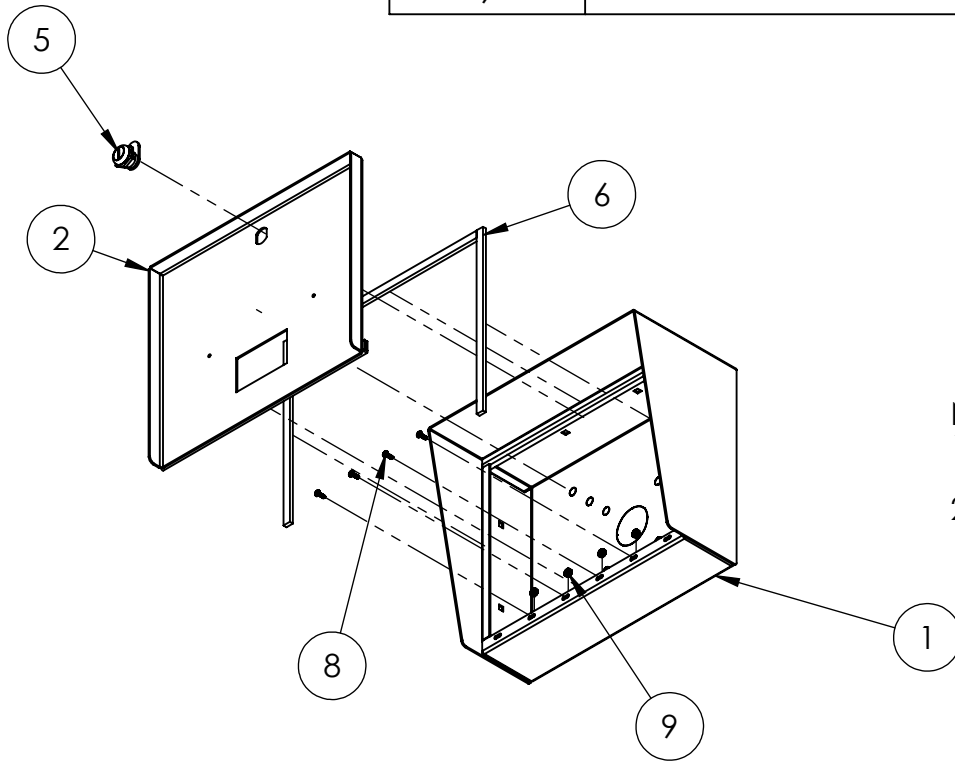

NOTES:

1. SEE STANDARD PREPARATION AND COATING INSTRUCTIONS FOR COATING PROCEDURE AND COLOR.
2. SEE STANDARD PACKAGING INSTRUCTIONS FOR PACKAGING PROCEDURE.



PEDESTALPRO.COM
1-800-660-3072

UNLESS OTHERWISE SPECIFIED:

DIMENSIONS ARE IN INCHES
TOLERANCES:
FRACTIONAL $\pm 1/32$
ANGULAR: $\pm 2^\circ$
TWO PLACE DECIMAL ± 0.010
THREE PLACE DECIMAL ± 0.005

INTERPRET GEOMETRIC
TOLERANCING PER:
ASME Y14.5 -2009

NAME	DATE
DRAWN	
CHECKED	

PROPRIETARY AND CONFIDENTIAL

THE INFORMATION CONTAINED IN THIS DRAWING IS THE SOLE PROPERTY OF PEDESTALPRO LLC. ANY REPRODUCTION IN PART OR AS A WHOLE WITHOUT THE WRITTEN PERMISSION OF PEDESTALPRO LLC IS PROHIBITED.

TITLE:
ASSEMBLY

Friday, April 21, 2023
10:46:52 AM

WEIGHT: 13.212

SIZE	PART NO.	REV
A	1210HOU-2NIP-01-304	A

NO SCALE

SHEET 2 OF 6