

**EVID**

**EV** Innovative Design

# Electro-Voice Ceiling Speaker User Manual



**EVID C4.2D**  
**EVID C8.2D**

Live For Sound  
[www.electrovoice.com](http://www.electrovoice.com)



---

Welcome.....	3
Safety First.....	3
Important Features.....	3
Model Summary .....	4
EVID C4.2D .....	4
EVID C8.2D .....	4
Packing List.....	4
Product Feature Identification.....	5
Installation and Wiring .....	5
Step 1 - Cut the Hole.....	5
Step 2 - Install C-Ring and/or Tile Rails.....	6
Step 3 - Attach Wiring to the Ceramic Connector.....	7
Step 4 - Connect an Auxiliary Support Line .....	7
Step 5 - Mount the Speaker into the Ceiling.....	8
Step 6 - Adjust the Tap Selector.....	8
Step 7 - Attach the Grille .....	9
Painting the Speaker .....	10
Painting Process .....	10
Specifications .....	11



## Welcome

Thank you for purchasing Electro-Voice loudspeakers. Read through this manual to familiarize yourself with features, applications, and precautions before you use these products.

Electro-Voice loudspeakers use innovative design and materials to provide premium-level performance in a flush-mount ceiling format. Two models are available: the EVID C4.2D with a 4-inch LF driver and a 0.75-inch, titanium-coated tweeter with waveguide; the EVID C8.2D with an 8-inch LF driver and a 1-inch titanium-coated tweeter with waveguide.

## Safety First

Suspending any object is potentially dangerous and should only be attempted by individuals who have a thorough knowledge of the techniques and regulations of suspending objects overhead. Electro-Voice strongly recommends all loudspeakers be suspended taking into account all current national, federal, state, and local laws and regulations. It is the responsibility of the installer to ensure all loudspeakers are safely installed in accordance with all such requirements. When loudspeakers are suspended, Electro-Voice strongly recommends the system be inspected at least once per year or as laws and regulations require. If any sign of weakness or damage is detected, remedial action should be taken immediately. The user is responsible for making sure the wall, ceiling, or structure is capable of supporting all objects suspended overhead. Any hardware used to suspend a loudspeaker not associated with Electro-Voice is the responsibility of others.



### Caution!

The seismic tab (auxiliary support ring) is not intended for primary suspension of the loudspeaker. The seismic tab should only be used as a secondary safety point.



### Caution!

Ceiling mount speaker's safety cable  
The safety cable should be installed with a minimum of 3-inches (76.2 mm) of slack.

## Important Features

- Model for model, has superior performance to competing brands
- Comes with both 70V/100V or 8-ohm operation standard
- Includes all installation accessories commonly needed for most jobs
- Designed for use in voice alarm systems

## Model Summary

### EVID C4.2D

The EVID C4.2D is ported and tuned to provide surprising bass response in such a compact package. Perfect for conventional rooms, its compact design fits in tight areas and has excellent bandwidth in an aesthetically unobtrusive installation profile. Its 4-inch woofer and waveguide-coupled, titanium-coated dome tweeter give smooth, wide frequency response. An easy 3-point mounting system is included for quick installations.

### EVID C8.2D

The EVID C8.2D has a specially tuned enclosure and 8-inch woofer to provide amazing bass response. The 1-inch waveguide-coupled tweeter give smooth controlled coverage out to 20 kHz. Perfect for installations where a flush-mount design is desired but demand for high-quality audio exists. A 4-point mounting system is included to make installations fast and easy.

## Packing List

Item	Qty.	Description
A	2	Speaker System
B	4	Tile Rails
C	2	C-Ring Support
D	2	Grille
E	1	Owner's Manual
F	4	Support Ring Screw
G	1	Cutout Template
H	2	Paint Shield

**Table 1:**  
*Packing List Qty. / Descriptions*

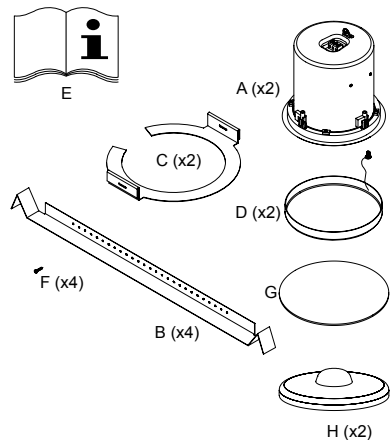

**Figure 1:**  
*Packing List Views*



**Product Feature Identification**

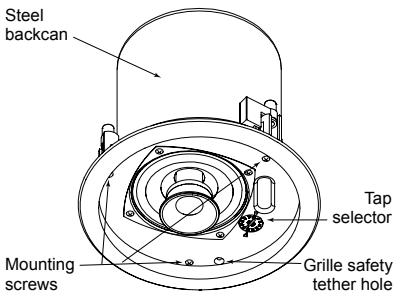

**Figure 2:**  
*Bottom of Speaker*

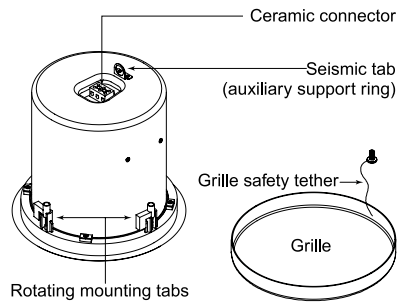

**Figure 3:**  
*Top of Speaker*

**Installation and Wiring**

The Electro-Voice mounting system has been designed so that, if necessary, the installation can be done from beneath the ceiling. In some cases with a suspended ceiling grid, however, it may be easier to access from both the top and bottom of the ceiling tile during the installation process. Typical installation hardware needed for either suspended ceilings or sheetrock ceilings is included. The ceiling speaker assembly is held in place by mounting tabs that securely grip the ceiling material. Input wiring is attached to a removable terminal block connector that can be pre-wired if necessary before speaker installation to speed up the installation process.

**Step 1: Cut the Hole**

For suspended tile or sheetrock ceilings, cut out the hole either by tracing the cardboard template or with a circular cutter set to the appropriate cutout size, as shown in Figure 4. If the wire has been pre-installed, pull the wiring through the cutout hole.

**Figure 4:**  
*Cut Ceiling Hole*

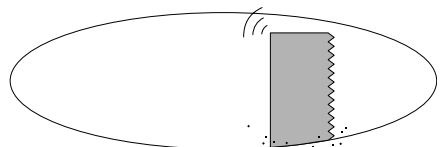

**Step 2: Install C-Ring and/or Tile Rails**

The Electro-Voice speakers come packaged with hardware: a C-ring and two tile rails.

For suspended ceiling installations, insert the C-ring through the hole cut in the ceiling tile. Place the C-ring around the hole with the tabs located as shown in Figure 5. Insert the tile rails through the cut hole in the ceiling tile. Snap the two rails into the two tabs in the C-ring and align the rails so that the ends extend OVER the T-channel grid on the side of the tile. Secure the rails onto the C-ring tabs by inserting a screw through each tab into the rail, as shown in Figure 5.

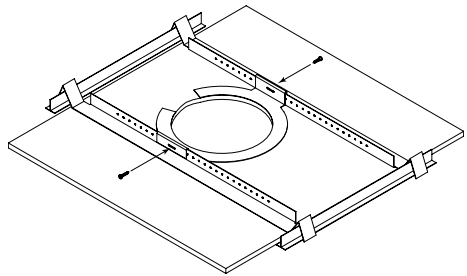

**Figure 5:**  
*Secure Rails to C-Ring*

**INSTALLATION NOTE: TILE RAILS AND C-RING**

Each speaker comes with two tile rails which are designed to fit either standard 24-inch-wide or 600-mm-wide tiles. It is important to note that the tile rail pieces do not actually attach to the T-grid struts. The ends of the rails sit OVER the T-grid strut. Normally, the tile supports the rails. The tile rails are pre-punched at regular intervals with holes along their length. This allows the C-ring to be positioned at any point along the rail. If the tile comes out or falls apart, the ends of the support rails fall onto the T-grid, which prevents the speaker assembly from falling.

Always use all included support hardware when installing into suspended ceiling tiles to make sure the installation is secure.

For sheetrock ceiling installations, the C-ring should be used by itself to reinforce the ceiling material and to spread out the pressure from the speaker hold-down tabs. Guide the C-ring through the cut hole in the ceiling, and place it on the back side of the hole before inserting the speaker.

# Installation and Wiring

## Step 3: Attach Wiring to the Ceramic Connector

Insert the bare end of wire into the appropriate connector terminals as described below and screw down the hold-down screw until tight, using a small screwdriver, as shown in Figure 6.

## Step 4: Connect an Auxiliary Support Line

Note the support ring on the back of the speaker. The ring allows for connection to a independent and secure anchor point, as shown in Figure 7. Construction codes often require the use of this secondary support point.

## Installation Note: Ceiling Tile

When mounting the units into 2'x2' or 2'x4' suspended ceiling tiles, **DO NOT** install them in lightweight fiberglass-type tiles without full secondary support for the speaker as noted in Step 4. Such tiles are not designed to support any substantial weight. Speaker installation without secondary support will cause the tile to sag and distort, even with the tile bridge installed. The secondary support line at the rear of the speaker **MUST** be strung taut in these situations and **MUST** remove most of the force of the speaker on the tile to ensure that the speaker does not deform the tile.

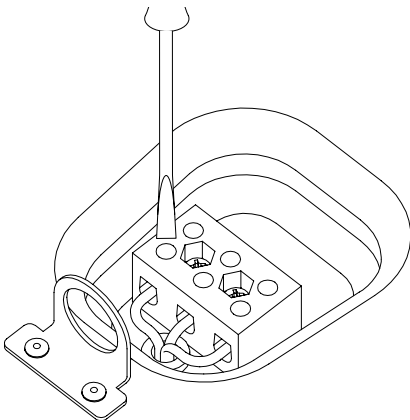

**Figure 6:**  
*Tighten with Screwdriver*

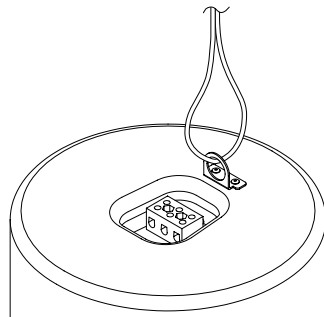

**Figure 7:**  
*Attach Auxiliary Support Line*

## Step 5: Mount the Speaker Into the Ceiling

Push the speaker into the ceiling hole until the front baffle rim is flush with the ceiling, as shown in Figure 8. Tighten the mounting tabs by turning the screw clockwise until the speaker is secure. Please note that the first clockwise quarter-turn rotates the attachment tabs outward. The remaining turns tighten the tabs down onto the back of the ceiling surface, as shown in Figure 9.

### INSTALLATION NOTE: MOUNTING TABS

For each attachment screw, first turn one half-turn counterclockwise to release the mounting tab from its guide.

## Step 6: Adjust Tap Selector

The tap selector switch is located on the front baffle. Adjust the speaker to the appropriate tap setting, as shown in Figure 10, before installing the grille. In some 70V/100V constant voltage installations it is advisable to leave the grilles off if final speaker audio level balance adjustments are to be made later. After the levels are adjusted the grilles can then be installed.

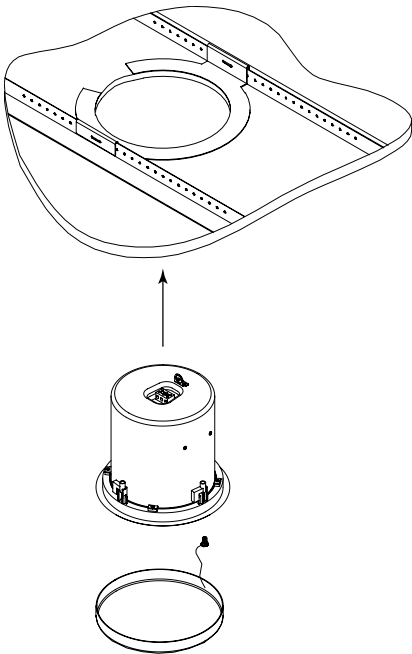

**Figure 8:**  
 Mount Speaker to Ceiling

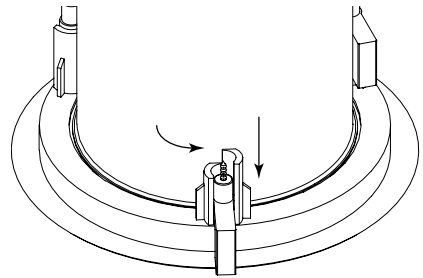

**Figure 9:**  
 Tighten Mounting Tabs

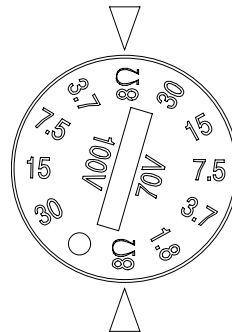

**Figure 10:**  
 Adjust Tap Selector



## Step 7: Attach the Grille

First, install the grille's safety tether by pushing the grille fastener into the hole in the front of the baffle, as shown in Figure 11. Second, press the grille into place until the front of the grille is flush with the rim of the baffle. Make sure the grille is securely seated to prevent it from vibrating loose.

If you need to remove the grille, the easiest way is to insert two bent paper clips or other pointed objects into holes in the grille, then apply slow even pressure to pull down on the grille until that section of the grille comes out slightly. Continue the same procedure around the perimeter of the grille, loosening a portion at a time until the grille is removed.

### INSTALLATION NOTE: GRILLE SAFETY FEATURE

Electro-Voice grilles features a unique safety tether to prevent the grille from falling if the grille is removed or comes loose after installation.

**Figure 11:**  
*Attach the Grille*

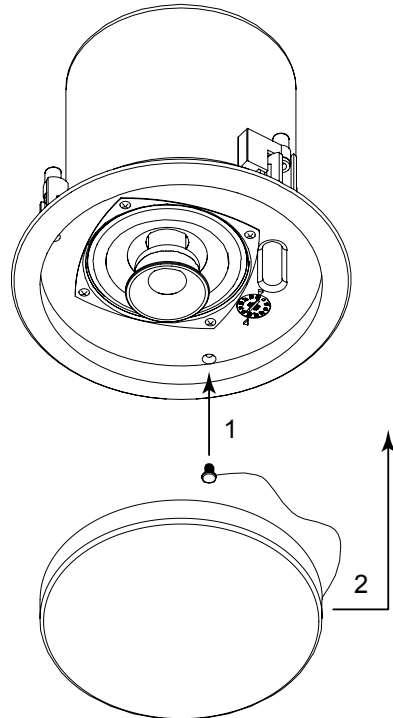

**Painting the Speaker**

If the speaker is installed in an area where the interior design requires a color match, these speakers are simple to paint. The speakers can accommodate almost any type of latex or oil-based paint. The bezel/rim can be painted before installation or after mounting into the ceiling.

**Painting Process**

Clean the rim and grille with mineral spirits or other light solvent. Do not use harsh solvents such as gasoline, kerosene, acetone, or other chemicals. If you use these cleaners you may permanently damage the enclosure. Also, don't use abrasive products such as sandpaper or steel wool.

Either by rolling or spraying, apply two or more thin coats of paint. If you are spraying, hold the spray can at the angles shown in Figure 12.

**Figure 12:**  
*Spray-Painting Angles*

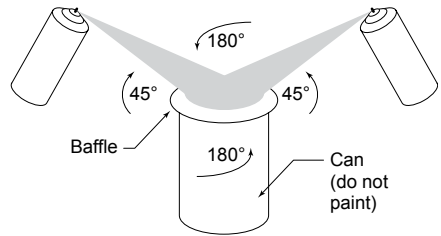

If you are also painting the grille, you must first remove the internal grille cloth. Spray painting is strongly recommended. If the grille is rolled or brush painted, the grille may become clogged with paint and the sound quality will suffer. After the paint has dried, replace the internal grille cloth.

If you wish to paint the speaker along with the ceiling after installation, insert a plastic or cardboard paint shield into the front of the speaker to mask the drivers and internal baffle, paint the speaker, then remove the shield.

# Specifications



Specification	EVID C4.2D	EVID C8.2D
<b>Dimensions (Depth x Diam.):</b>	6.9 in x 7.1 in (176 mm x 181 mm)	10.0 in x 10.6 in (255 mm x 270 mm)
<b>Bezel Diameter:</b>	8.3 in (210 mm)	11.8 in (300 mm)
<b>Weight:</b>	6 lb (2.7 kg)	11 lb (5.0 kg)
<b>Cabinet Construction:</b>	Steel Enclosure and UL94V-0 Rated Baffle and Bezel	
<b>LF Transducer:</b>	4" (102 mm) High-Compliance Driver (Weatherized Cone)	8" (205mm) High-Compliance Driver (Weatherized Cone)
<b>HF Transducer:</b>	0.75 in (19 mm) Ti-Coated Dome	1.00 in (25.4 mm) Ti-Coated Dome
<b>Mounting System:</b>	Integrated 3-Point Toggle Anchors	Integrated 4-Point Toggle Anchors
<b>Available Colors:</b>	White (Paintable Surface)	
<b>Grille Construction:</b>	Powder-Coated Steel	
<b>Acoustic Design:</b>	Ported Cabinet, Two-Way Design, Internally Damped w/Passive Crossover	
<b>Frequency Response:</b>	65 Hz - 20 kHz	50 Hz - 20 kHz
<b>Power Handling (8 Ohms):</b>	50 W (with Overload Protection)	75 W (with Overload Protection)
<b>Coverage Pattern:</b>	130° Conical	110° Conical
<b>Sensitivity (SPL 1W/1m):</b>	86 dB	91 dB
<b>Input Configuration:</b>	8 ohms; 70 V/100 V	
<b>70V/100V Power Taps:</b>	1.8 (70 V Only)/3.7/7.5/15/30 W	
<b>Included Accessories:</b>	Tile Bridge; Mounting Ring	

**Bosch Security Systems, Inc**

12000 Portland Avenue South

Burnsville MN 55337

USA

**[www.electrovoice.com](http://www.electrovoice.com)**

© Bosch Security Systems, Inc, 2015

2015.09 | 02 | F.01U.317.228