



THIS PRODUCT MUST BE INSTALLED IN ACCORDANCE WITH THE APPLICABLE INSTALLATION CODE BY A PERSON FAMILIAR WITH THE CONSTRUCTION AND OPERATION OF THE PRODUCT AND THE HAZARDS INVOLVED

CE PRODUIT DOIT ÊTRE INSTALLÉ SELON LE CODE D'INSTALLATION PERTINENT, PAR UNE PERSONNE QUI CONNAÎT BIEN LES PRODUIT ET SON FONCTIONNEMENT AINSI QUE LES RISQUES INHÉRENTS

I. Introduction

This manual is for the Blue Light Emergency Phone Tower (model **ETP-MT**), Radius Emergency Phone Tower (model **ETP-MT/R**) and the ECO TOWER® Emergency Phone Tower (model **ETP-MTE**) installation only. For instructions on installing the anchor bolts into the foundation, see the **TOWER ANCHOR BOLT INSTALLATION INSTRUCTIONS** or **ETP-PDMK INSTRUCTIONS** for Parking Deck Mounting Kits.

II. Contents

Before beginning installation, make sure you have all the included components. Each **TOWER PARTS** kit includes:

Qty.	Part Number	Description
3	42941	10-24 x 3/4" Pin-In-Torx Pan head(TS-20 driver required)
2	42843	6-32 hex nut
1	68590	LED Panel Light (12-24V AC/DC - 120VAC)
1	ETP-EL or ETP-EL12/24	120VAC LED Blue Light or 12/24V AC/DC LED Blue Light

III. Installation



It is the installer's obligation to ensure compliance with all national, regional, and local regulations.

1. After removing the tower from its shipping carton, install the LED Blue Light on top of the tower, feeding the power cord and control wires through the top of the tower. If installing an **ETP-MT/R** tower series, you will need to remove the cap plate atop the tower first. Fasten the LED Blue Light to the tower with three (3) 10-24 pan head tamperproof screws. Replace the cap plate at the top, if used. *It is not necessary to connect power lines at this point.*
2. Slide the LED Panel Light over the studs with the LEDs facing down. Tighten down using the two (2) 6-32 hex nuts (provided). Be careful not to over tighten to avoid cracking the LED Panel Light.
3. Install one 3/4"-10 hex nut and one washer (found in the **MT/R BOLT KIT** or **MT BOLT KIT**) on each anchor bolt 2.5-3.5" above grade to top of washer. This will allow for a 1/2" air gap between the foundation and the tower, which will allow airflow and prevent moisture problems. Verify that the nuts are level (0° pitch). – See **Figure 1** –

TOWER PARTS Kit Installation Instructions

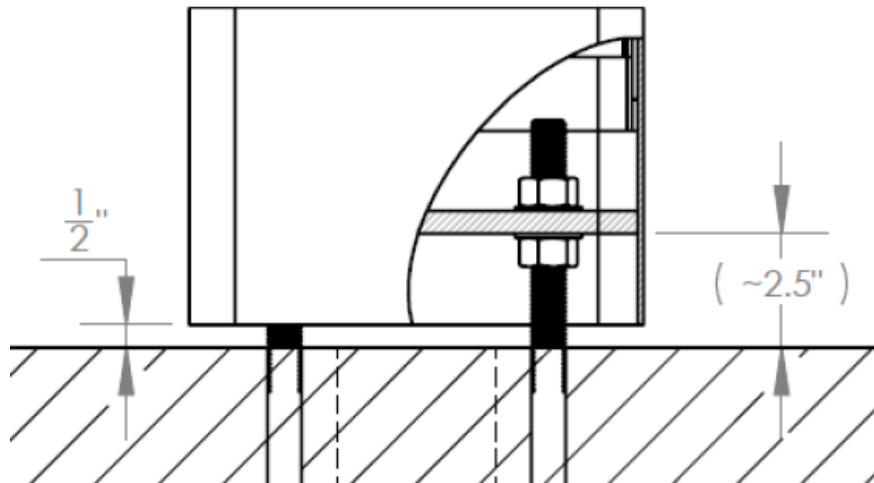

Figure 1: Tower Installation



To insure proper grounding of all electrical components, the tower mount should be effectively earth grounded from the grounding stud (located in the electrical box) with 6 AWG or better insulated, stranded copper wire to the metallic power service raceway (conduit) or an 8' or longer corrosion-resistant ground spike.

4. After removing the access panel from the tower's rear access opening, install the tower onto the bolts with the emergency phone opening oriented in the desired direction. Install second set of 3/4"-10 hex nuts and washers. Tighten the upper nuts; the bottom set is only for leveling.
5. Wire incoming power to the LED Blue Light and to the LED Panel Light. The LED Panel Light operates on 12VDC up to 120VAC and is not polarity sensitive. The high voltage LED Blue Light operates only on 120VAC. The low voltage LED Blue Light, if used, operates on 12/24VDC or 24VAC only. Please refer to the wiring instructions as shown in **Figure 2** and **Figure 3**.

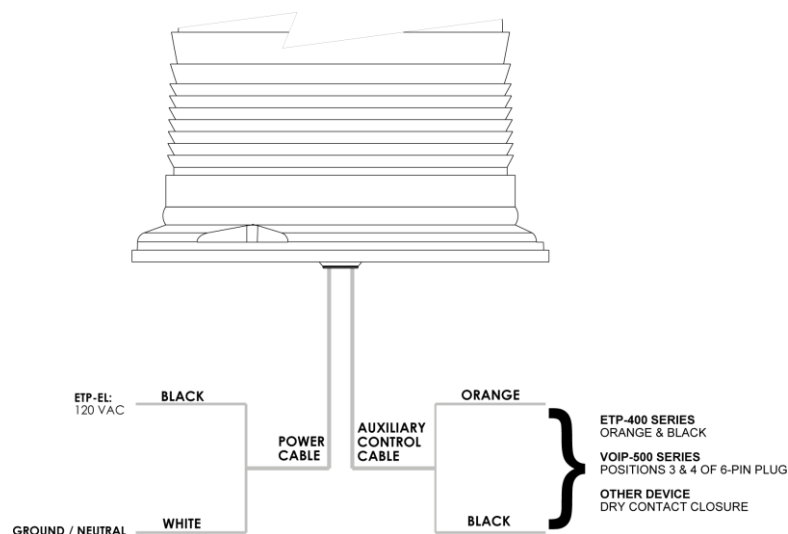

Figure 2: Electrical connections to the ETP-EL LED Blue Light

TOWER PARTS Kit Installation Instructions

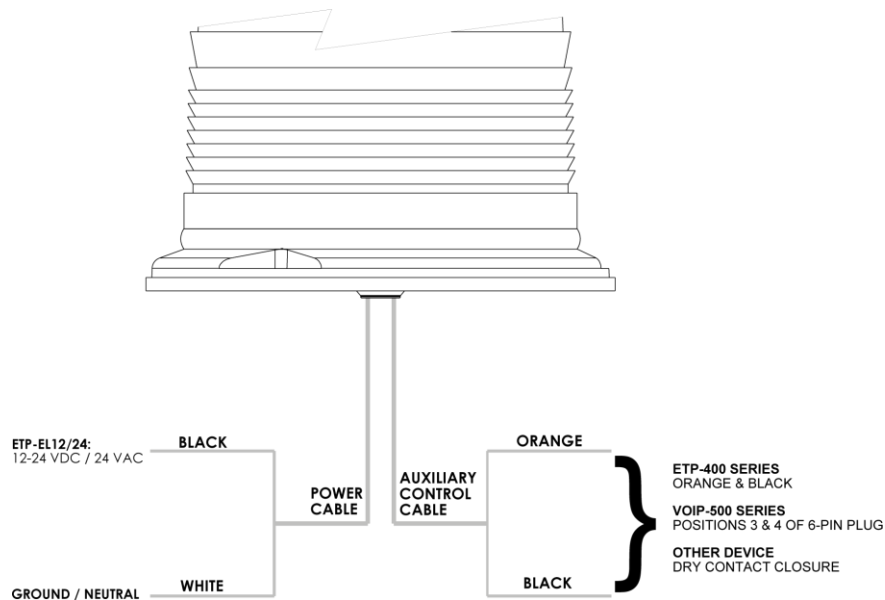

Figure 3: Electrical connections to the ETP-EL12/24 LED Blue Light

6. When using the **ETP-EL** Series LED Blue Light with **ETP-400** Series Emergency Phones, connect the orange and black auxiliary control cable pair of the LED Blue Light to the orange and black wires of the emergency phone. Refer to the emergency phone manual for information regarding the programming of your phone.
7. When using the **ETP-EL** Series LED Blue Light with **VOIP-500** Series Emergency Phones, connect the orange and black auxiliary control cable pair of the LED Blue Light to positions 3 and 4 (Aux. Output 2) of the 6-pin connector plug of the **VOIP-500** Series Phone.
8. Re-attach the access panel over the access opening.

IV. Power Requirements:

ETP-EL: 96-132VAC, 7.8 Watts (35A peak inrush)

ETP-EL12/24: 10-30VDC / 20-28VAC, 7.5 Watts, 1.5 Watts low power steady mode (18A peak inrush)

LED Panel Light: 12VDC, 1.2 Watts and 24VDC / 24 VAC / 120VAC, 1.63 Watts

V. OP4 / OP5 Arm Installation (optional)

1. Remove tower cap plate. – See **Figure 4** –
2. Pull the LED Blue Light and camera cables through hollow arm channel.
3. Attach LED Blue Light using the three (3) 10-24 tamperproof screws provided in the **OP 4 TOWER PTS** package. If installing a camera, attach the camera to the 1.5" NPT coupling of the arm. (Hardware is not provided for the camera). Pull cables into tower.
4. Nuts and bolts are provided in the **OP 4 TOWER PTS** to attach the arm to the tower itself. Reach through the top of the tower to tighten the bolts. Replace the tower cap plate.

TOWER PARTS Kit Installation Instructions

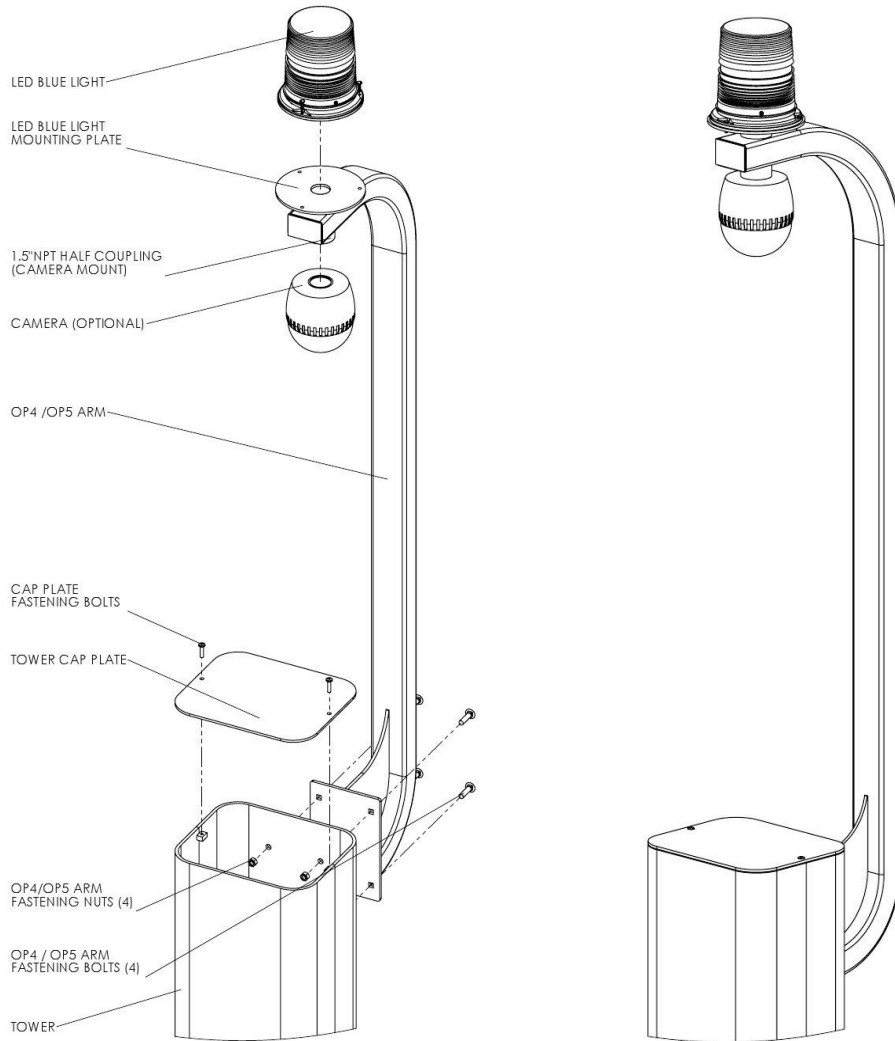

Figure 4: Installation (exploded and assembled views) of OP4 / OP5 Arm to Tower