

SDC Spectra™

S6000 Series

Electrified Architectural
Rim & Vertical Rod Exit Devices



SDC's Spectra™ S6000 series electrified architectural rim and vertical rod exit devices offer several electrified options to complement your access control system and meet virtually any application. UL listed and ANSI/BHMA A156.3 Grade 1 compliant, S6000 series devices comply with all national and state building and fire life safety codes.

Designed for a modern look and quiet push pad operation, S6000 series devices are panic or fire rated exit and are available in rim mount or surface vertical rod configurations.

Trim is ordered separately, see related products.

MODELS

S61 Rim

S62 Surface Vertical Rod (SVR)

STANDARD FEATURES

- Electrified architectural design
- Panic and fire rated devices
- Durable stainless steel construction
- Corrosion resistant
- High traffic use

OPTIONAL FEATURES

- Request-to-exit (REX)
- Latch status (LS)
- Less bottom rod*
- Motorized electric latch retraction and dogging
- Motorized electric latch retraction and dogging, external module
- Electric dogging
- Alarmed exit, battery powered
- Alarmed exit, hardwired

* Available for S62 surface vertical rod devices only.



APPLICATIONS

- Commercial and industrial
- Hollow metal, wood and mineral core doors
- New or retrofit construction
- Rim and surface vertical rod devices
- Single or pair of doors
- Wide stiles (4" minimum)

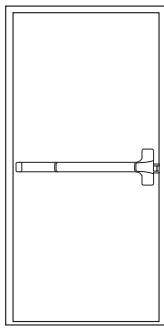
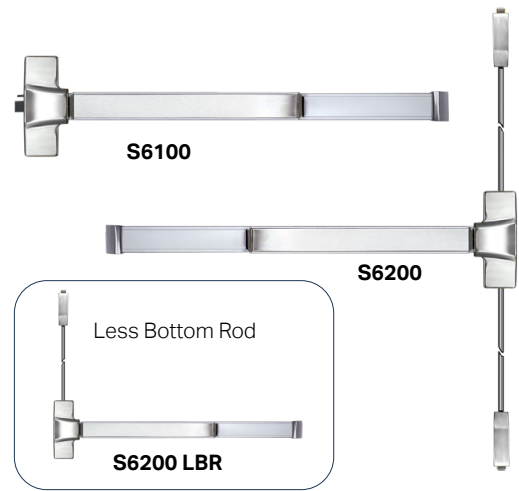

Rim device on single door.

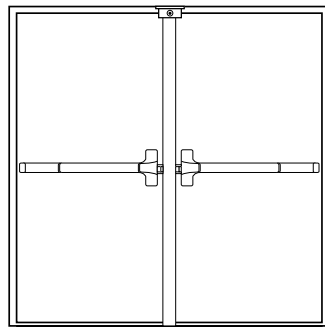

Two rim devices on two independent active doors with removable mullion.

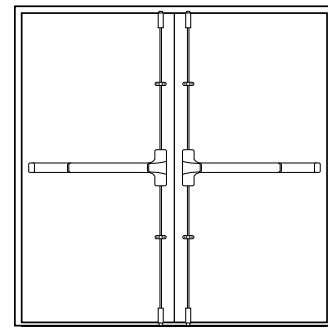

Two surface vertical rod devices - same direction. Overlapping astragal not required.

MOTORIZED ELECTRIC LATCH RETRACTION & DOGGING

Electric latch retraction enables electric access control and dogging of mechanical exit devices. When energized the motor retracts the exit device latch and pulls the pushpad on most devices into the dogged (depressed) position enabling momentary or sustained push and pull operation of the door. S6000E models house all electronics within the rail of the device behind the access cover, whereas S6000EM models utilize external electronic modules for enhanced security or to accommodate smaller field cut devices for smaller openings.

ELECTRIC DOGGING

When energized by a remote switch, manually depressing the pushpad causes the pushpad and latch to remain retracted (unlocked) providing push-pull door operation. When de-energized or signaled by a fire alarm, the pushpad and latch are released. S6000G models are failsecure and will remain locked in the event of power loss.

ALARMED EXIT

Audible alarm and multi-colored LED provide alert to emergency egress. A field selectable alarm mode includes continuous alarm with manual key reset, fixed automatic rearming two minutes after door close, or dual rearming either automatically two minutes after door close or by key before automatically rearmed. S6000A models are battery powered, whereas S6000B models are hardwired with battery backup to provide remote monitoring and alarm shunt.



 SPECIFICATIONS

	S61	S62
Device Type	Rim	Surface Vertical Rod (SVR)
Door Width	36", 42", 48"	36", 42", 48"
Door Height	-----	7'0"
Door Thickness	1¾" - 2"	1¾" - 2"
Door Stile	Wide (4" Minimum)	Wide (4" Minimum)
Handing	Non-Handed	Non-Handed
Headcover	Stainless Steel	Stainless Steel
Rail	Stainless Steel	Stainless Steel
End Cap	Stainless Steel	Stainless Steel
Projection	3½" Neutral 2⅝" Depressed	3½" Neutral 2⅝" Depressed
Latch	¾" Throw Stainless Steel	¾" Throw (Top & Bottom) Stainless Steel (Top & Bottom)
Deadlatch	⅝" Throw, Stainless Steel	-----
Strike	Aluminum	Aluminum
Vertical Rods	-----	Aluminum
Weight	13 lbs	15 lbs
Request-To-Exit (REX)	SPDT	SPDT
Latch Status (LS)	250 mA @ 30 VDC Resistive	250 mA @ 30 VDC Resistive
Motorized Electric Latch Retraction & Dogging	(E & EM - Options) 24 VDC ± 10% 700 mA Inrush, 200 mA Continuous	(E & EM - Options) 24 VDC ± 10% 700 mA Inrush, 200 mA Continuous
Electric Dogging	(G - Option) 12/24 VDC ± 10%, Auto-Sensing 170 mA @ 12 VDC, 100 mA @ 24 VDC	(G - Option) 12/24 VDC ± 10%, Auto-Sensing 170 mA @ 12 VDC, 100 mA @ 24 VDC
Alarmed Exit, Battery Powered	(A - Option) 9V Battery Powered	(A - Option) 9V Battery Powered
Alarmed Exit, Hardwired	(B - Option) 12/24 VDC ± 10%, Auto-Sensing 20 mA @ 12/24 VDC 9V Battery Backup	(B - Option) 12/24 VDC ± 10%, Auto-Sensing 20 mA @ 12/24 VDC 9V Battery Backup

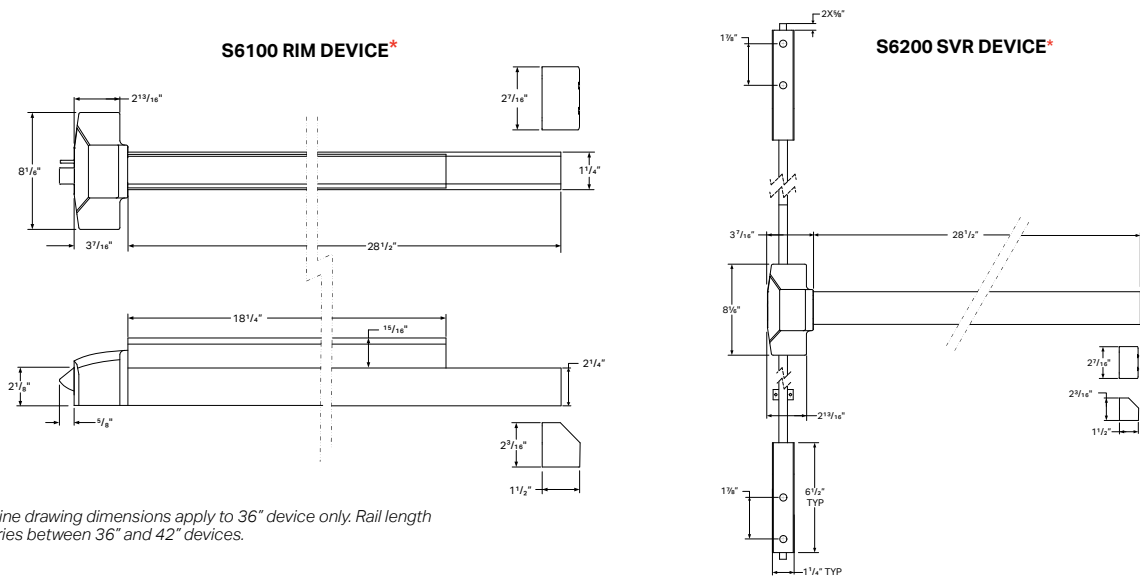

* Line drawing dimensions apply to 36" device only. Rail length varies between 36" and 42" devices.

CERTIFICATIONS

- UL 305 Panic Hardware
- UL 10C Positive Pressure Fire Tests
- ANSI/BHMA A156.3 Grade 1

HOW TO ORDER

FOLLOW STEPS FOR ORDERING

 Designates optional step

1| SPECIFY MODEL

- S61** Rim
- S62** Surface Vertical Rod (SVR)

2| SPECIFY FUNCTION

- 01** Exit Only (No Trim)
- 02** Dummy Trim (No Cylinder Prep)
- 03** Key Retracts Latchbolt (Nightlatch)
- 08*** Key Locks/Unlocks Lever (Classroom)
- 14*** Lever Always Active (Passage)

* Not applicable for use with S6000A or S6000B alarmed exit models.

3| SPECIFY RATING

- P** Panic Device  Standard
- F** Fire-Rated Device

4| SPECIFY FINISH

- U** 630 Dull Stainless  Standard

5| SPECIFY LENGTH

- 36** 36" Door Opening  Standard
- 42** 42" Door Opening
- 48** 48" Door Opening

6| SPECIFY OPTIONS

- R** Request-To-Exit (REX)
- L** Latch Status (LS)
- LBR*** Less Bottom Rod, Panic
- LBRF*** Less Bottom Rod, Fire-Rated

* Available for S62 surface vertical rod devices only.

7| SPECIFY ELECTRIFICATION*

- E** Motorized Electric Latch Retraction & Dogging
- EM** Motorized Electric Latch Retraction & Dogging, External Module
- G** Electric Dogging
- A** Alarmed Exit, Battery Powered
- B** Alarmed Exit, Hardwired

* Specify one electrification option only.

STEP NUMBER:	1	2	3	4	5	6	7
ORDERING EXAMPLE:	S61	02	P	U	36	R	E



RELATED PRODUCTS

ELECTRIFIED MORTISE DEVICES



SDC's Spectra™ S6300 series electrified architectural exit devices offer several electrified options to complement your access control system and meet virtually any application.

[CLICK TO VIEW](#)

DELAYED EGRESS DEVICES



Stop theft, control pedestrians in public facilities and airports, control wandering patients and guard against infant abduction.

[CLICK TO VIEW](#)

COMPATIBLE TRIM

SDC exit device trim is stainless steel. Key cylinders are not included, order separately.

Series	EK	GK	SP	EKE	GKE
Trim Style	Eclipse Escutcheon	Galaxy Escutcheon	Saturn Escutcheon	Eclipse Escutcheon	Galaxy Escutcheon
Trim Type	Mechanical	Mechanical	Mechanical	Electrified	Electrified
02 Dummy	EK02U	GK02U	SP02U	----	----
03 Nightlatch	EK03U	GK03U	SP03U	EKE03U**	GKE03U**
08 Classroom*	EK08U	GK08U	----	----	----
14 Passage*	EK14U	GK14U	----	----	----

* Not applicable for use with S6000A or S6000B alarmed exit models.

** Not applicable for use with S6000E or S6000EM motorized electric latch retraction models

COMPATIBLE KEY CYLINDERS

CYL-6KDQ Mortise Cylinder, 6-Pin, Keyed Different



CYL-6KAQ Mortise Cylinder, 6-Pin, Keyed Alike

RIM-CYL-KA* Rim Cylinder, 6-Pin, Keyed Alike

* For EK03U, GK03U and SP03U trim only.

REPLACEMENT STRIKES

ST1P Rim Strike, 1³/₁₆" Projection

ST1F Rim Strike, 1³/₁₆" Projection, Fire-Rated

ST2DF Double Door Rim Strike, 1³/₁₆" Projection

ST2P Vertical Rod Top Strike, 2⁹/₃₂" Projection

ST2F Vertical Rod Top Strike, 1¹/₈" Projection, Fire-Rated

ST28T Threshold Strike, 3/8" Projection



REMOVABLE MULLION

KR90F* Removable Mullion, 11 Gauge Steel, 8' x 2" x 2"

ST1MP Mullion Strike, 7/8" Projection

ST1MF Mullion Strike, 7/8" Projection, Fire-Rated



* Key cylinder not included, order separately.

COMPONENT CONSIDERATIONS

LOW ENERGY OPERATORS

[CLICK TO VIEW](#)



SDC's low energy swing door operators are designed for applications requiring ADA compliance, user convenience and touchless solutions. The state-of-the-art microprocessor-based operator is self-tuning and self-learning while offering non-handed operation, full mechanical stops, door sequencing and a variety of interface options for sensors, push-plates, fire alarms and electrified locks. A built-in 1 Amp power supply allows users to power electric latch retraction directly from the operator.

POWER TRANSFER DEVICES

[CLICK TO VIEW](#)



Electrified power transfer hinges (PTH Series), loops (PT Series) and mortise devices (PTM Series) provide both surface and concealed methods for running wires from the frame to transfer power and monitoring signals to doors equipped with electric locks and exit devices. Wireless power transfer devices (WPT Series) wirelessly transfer power and monitor latch bolt status, REX or data signals to electrified locks and latches.

DOOR PROP ALARMS & ANNUNCIATORS

[CLICK TO VIEW](#)



Multi-mode annunciators, like SDC's EA series door prop alarm, EA100 and 400 series LEDs, sirens, buzzers and speakers come in a variety of door, frame, wall, ceiling or single and double gang box configurations to provide the ultimate in door status indication, access control system compatibility and control. SDC door prop alarms are compatible with all access control systems but can also function as a standalone solution.

KEYPADS & READERS

[CLICK TO VIEW](#)



SDC has a variety of digital keypad and proximity card access control system equipment to meet any need. SDC's keypads and readers are engineered to provide real-world door control of a single opening up to 100 doors, such as indoor, outdoor and PC-based systems, while ensuring fire and life safety code compliance along with superior expandability and flexibility in authorization identification, authentication, access approval and accountability of entities through login credentials.

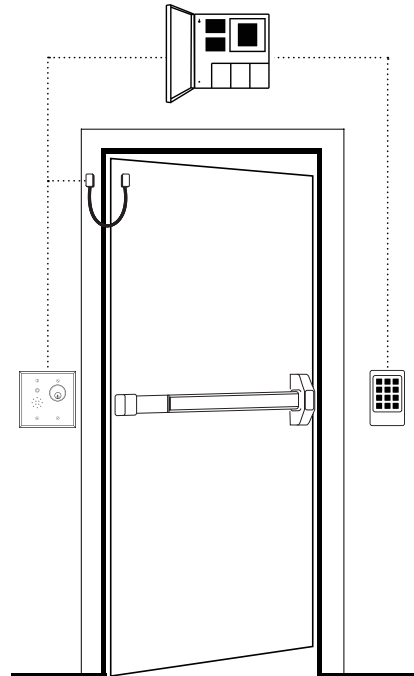

POWER CONTROLLERS

[CLICK TO VIEW](#)



SDC access control power supplies have been developed specifically to support access controls and electric locking hardware. They are UL listed and provide filtered and regulated linear DC power, with optional control logic, component interface, alarm interface and battery back-up to meet the requirements of single and multiple access-controlled openings. The circuitry design is ideal for the inductive loads generated by access control hardware for high performance and longevity.

DOOR CONTROLS & BACKUP BATTERIES

[CLICK TO VIEW](#)



SDC's door control relay modules ensure compatibility of access hardware components and simplify system installation and troubleshooting. Different modules may be specified for one power supply. The isolated relay design allows trigger signals over small gauge cable runs of 22 gauge wire up to 1,000 feet from the trigger device to the module. SDC's engineered system design services are available when you purchase SDC locks, control modules and power controllers for your door opening applications.