



24-Port Blank Angled Keystone Shielded 1U Patch Panel

TC-KP24SA (v1.0R)

- 24-port blank angled keystone shielded patch panel
- 1U 19" rackmount ready
- Angled keystone design for easy cable management
- Use with TRENDnet keystone jacks TC-K06C6A, TC-K25C6BK, or TC-K25C6 (sold separately)
- Shielded housing protects against EMI/RFI noise

TRENDnet's 24-Port Blank Angled Keystone Shielded 1U Patch Panel, model TC-KP24SA, is designed for use with TRENDnet's Cat6A shielded keystone jack (TC-K06C6A). When used together, they create a patch panel solution suitable for gigabit and 10G Copper Ethernet network applications. Use this shielded patch panel with Cat6A shielded cabling, which is specifically designed to eliminate EMI and crosstalk ensuring peak performance and data integrity.

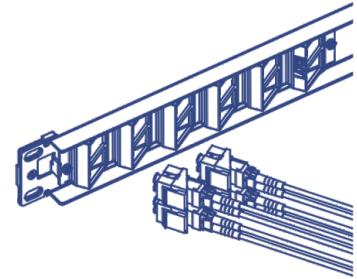
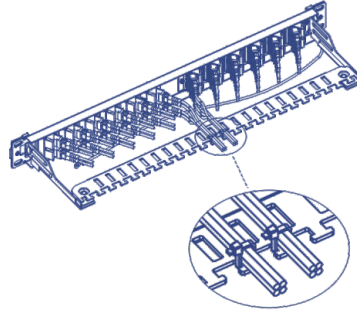
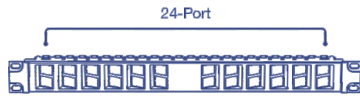

24-Port

24-Port blank keystone shielded 1U patch panel is designed for use with TRENDnet's Cat6A shielded keystone jacks (sold separately).

Angled Design

19" 1U sturdy metal rackmount housing with angled keystone design for easy cable management

Connectivity

Ideal for high-speed gigabit and 10G Copper Ethernet network applications when used with TRENDnet's Cat6A shielded keystone jacks (sold separately).

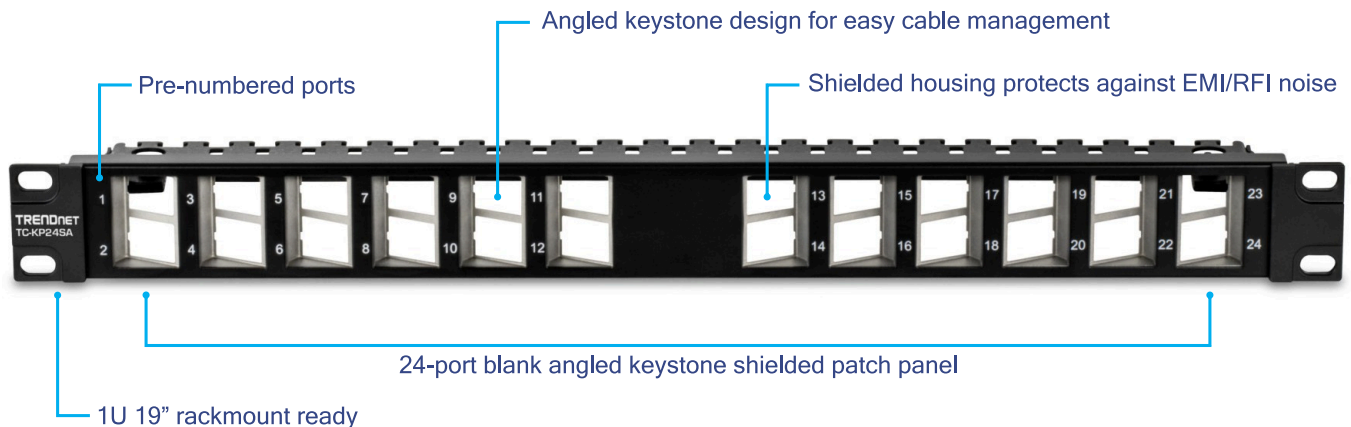

SPECIFICATIONS

Features

- 24-port STP blank keystone shielded patch panel
- 1U 19" rackmount ready
- Pre-numbered ports
- EIA-310-D standard compliance
- Use with TC-K05LC shielded keystone jack (sold separately)

Materials

- SPCC steel construction
- Black coating

Dimensions

- 483 x 45 x 94mm (19 x 1.77 x 3.7 in.)

Weight

- 665g (1.5 lb.)

Warranty

- 2 year

Package Contents

- TC-KP24SA
- Mounting hardware
- Grounding wire
- Marking labels
- Quick Installation Guide

All references to speed are for comparison purposes only. Product specifications, size, and shape are subject to change without notice, and actual product appearance may differ from that depicted herein.