

**INSTALLATION INSTRUCTIONS**  
**WHEELOCK ELUXA MULTI-TONE STROBE (ELMTS)**  
**WITH PRE-WIRE/PRE-TEST (WALL MOUNT)**

Use this product according to this instruction manual. Please keep this instruction manual for future reference.

**GENERAL:**

The Wheelock Eluxa series ELMTS Multi-Tone Strobe appliances are designed for easy installation with a pre-wire capable mounting plate. Eluxa Multi-Tone Strobe is UL Listed for indoor fire protection service under Standard 1971 for Signaling Devices for the Hearing Impaired, UL 1638 for Visual Signaling Devices and Standard 464 for Audible Signaling Devices. The Eluxa Multi-Tone is also ULC Listed under Standard CAN/ULC-S526-16 for Visual Signaling Devices and under Standard CAN/ULC-S525-16 for Audible Signaling Devices for Fire Alarm Systems. These models are listed for indoor use only, and for wall mount only when used with the backboxes specified in these instructions (see mounting options).

Eluxa Multi-Tone appliances can be field set to produce any one of eight commonly used alarm tones. Sound output can be field set to provide either HIGH (HI) dBA or STANDARD (STD) dBA sound output level. ELMT Multi-Tone appliances are designed for use with either filtered or unfiltered Full-Wave-Rectified (FWR) input voltage. All inputs are polarized for compatibility with standard reverse polarity supervision of circuit wiring by a Fire Alarm Panel (FACP). The horn portion of the ELMTS appliance can be field set to provide a synchronized code 3 horn when used in conjunction with the Dual Sync Module (DSM) or Wheelock power supply.

The Wheelock Eluxa Series meets NFPA 2016 20 millisecond light pulse duration code requirements. In addition, the Wheelock Eluxa and LED3 product lines have been UL/ULC listed as compatible with all Fire Alarm Control Panels (FACP) and accessories that have been determined to be compatible with Wheelock model RSS Strobe based products including the RSS, CH, E, EH, ET, ST, HS, MT, S8, SA, STH and Z Series. The maximum number of Eluxa devices per NAC is determined by dividing the maximum current rating of the FACP NAC by the total current rating of one Eluxa device, with a maximum of 105 Eluxa (or LED3) devices per NAC. Refer to FACP installation instructions for more detail. The Wheelock Eluxa Series and Exceder LED3 Series strobes may be installed in the same notification zone and field of view with any RSS Strobe based product.

Eluxa Strobe can provide a non-synchronized strobe appliance when connected directly to a Fire Alarm Control Panel (FACP), or provide a synchronized strobe appliance when used in conjunction with an FACP that incorporates the Wheelock Sync Protocol, a Dual Sync Module (DSM) or a Wheelock Power Supply.

**CAUTION:** Do not change factory applied finishes. "DO NOT PAINT".

**ATTENTION:** Ne pas modifier les finitions appliquées en usine. "NE PAS PEINTURER"

**IMPORTANT:** PLEASE READ THESE INSTRUCTIONS CAREFULLY. FAILURE TO COMPLY WITH ANY OF THE FOLLOWING INSTRUCTIONS COULD RESULT IN IMPROPER APPLICATION, INSTALLATION AND/OR OPERATION OF THESE PRODUCTS IN AN EMERGENCY SITUATION, WHICH COULD RESULT IN PROPERTY DAMAGE AND SERIOUS INJURY OR DEATH.

**SPECIFICATIONS:**

| Table 1: Specifications |   |
|-------------------------|---|
| Models                  | ELMTS (Eluxa Multi-Tone Strobe)   |
| Agency                  | Strobe: UL1638, UL1971, CAN/ULC-S526-16<br>Multi-Tone: UL464, CAN/ULC-S525-16 |
| Input Voltage           | DC or FWR, 24V Regulated, 16 to 33V (All models)                              |
| Volume Setting          | STD (standard) or HI (high) (selectable via DIP switch SW1 POS1)              |
| Tone Setting            | Eight (8) selectable tones (via DIP switch SW1, POS 2,3,4)                    |
| Strobe Light Output     | Strobe: 15, 30, 75, 110, 135, 185cd (field selectable)                        |
| NAC Characteristics     | Max. line resistance: 35Ω   |
| Environmental           | Indoor Use Only, 0° C - 50° C (32° F - 122° F) 93% R.H.                       |

| Table 2: Eluxa Strobe Current Ratings (AMPS) ** |                           |       |       |                             |       |       |
|---|---------------------------|-------|-------|-----------------------------|-------|-------|
|   | Regulated 24DC (16-33VDC) |       |       | Regulated 24FWR (16-33VRMS) |       |       |
|   | Candela Setting           | 15cd  | 30cd  | 75cd                        | 110cd | 135cd |
| DC  | 0.022                     | 0.030 | 0.060 | 0.086                       | 0.125 | 0.185 |
| FWR   | 0.036                     | 0.050 | 0.092 | 0.142                       | 0.196 | 0.274 |

\*\* Setting will determine the current draw of the product.

**NOTES:**

- The strobe will produce 1 flash per second over the "Regulated Voltage" range.
- Strobe is not designed to be used on coded systems in which the applied voltage is cycled on and off.
- The maximum number of Eluxa or LED3 strobes on a single notification appliance circuit shall not exceed 105.
- These appliances are UL Listed as "Regulated". They are intended to be used with FACP's whose notification circuits are UL Listed as "Regulated." Refer to the FACP instructions or the Wheelock Strobe Compatibility Data Sheet (P85328) for special application and strobe synchronization compatibility.
- The effect of shipping and storage temperatures shall not adversely affect the performance of the appliance when it is stored in the original cartons and not subjected to misuse or abuse.

When calculating the total currents: Use Table 2, 3 to determine the highest value of "RMS Current" for an individual appliance, then multiply these values by the total number of appliances; be sure to add the currents for any other appliances powered by the same source and include any required safety factors. Make sure that the total RMS current required required by all appliances that are connected to the system's PRIMARY and SECONDARY power sources, NAC circuits, DSM Sync Modules or Wheelock Power Supplies does not exceed the power sources' rated capacity or the current ratings of any fuses on the circuits to which these appliances are wired. Check the minimum and maximum output of the power supply and standby battery, and subtract the voltage drop from the circuit wiring resistance to determine the applied voltage to the appliance.

**CAUTION:** If ELMT Multi-Tone appliances are operated within 15 inches of a person's ear, they can produce a sound pressure level that exceeds the maximum 120 dBA permitted by ADA and OSHA rules. Exposure to such sound levels can result in damage to a person's hearing.

**ATTENTION:** Si les appareils ELMT Multi-Tone sont utilisés à moins de 15 pouces de l'oreille d'une personne, ils peuvent produire un niveau de pression acoustique supérieur à la vitesse maximale de 120 dBA permise par les règles de l'ADA et de l'OSHA. L'exposition à de tels niveaux sonores peut endommager l'ouïe d'une personne.

| Table 3: Current and Sound Pressure Ratings for ELMT Multi-Tone Appliances |        |                            |           |                                    |     |     |   |     |     |
|--|--------|----------------------------|-----------|------------------------------------|-----|-----|---|-----|-----|
| Tone   | Volume | Maximum RMS Current (AMPS) |           | Reverberant dBA at 10ft Per UL 464 |     |     | Anechoic dBA at 10 ft Per CAN/ULC S525-16 |     |     |
|  |        | 16-33VDC                   | 16-33VFWR | 16V                                | 24V | 33V | 16V                                       | 24V | 33V |
| Horn   | HI     | 0.108                      | 0.087     | 88                                 | 91  | 93  | 95  | 99  | 100 |
|  | STD    | 0.044                      | 0.045     | 82                                 | 86  | 88  | 89  | 93  | 94  |
| Bell   | HI     | 0.053                      | 0.067     | 80                                 | 83  | 87  | 85  | 89  | 91  |
|  | STD    | 0.024                      | 0.028     | 72*                                | 76  | 80  | 77  | 81  | 84  |
| March Time   | HI     | 0.104                      | 0.087     | 85                                 | 88  | 90  | 95  | 99  | 100 |
|  | STD    | 0.087                      | 0.045     | 79                                 | 83  | 85  | 89  | 93  | 94  |
| Code 3 Horn  | HI     | 0.122                      | 0.087     | 84                                 | 87  | 89  | 95  | 99  | 100 |
|  | STD    | 0.035                      | 0.045     | 78                                 | 82  | 85  | 89  | 93  | 94  |
| Code 3 Tone  | HI     | 0.135                      | 0.110     | 81                                 | 85  | 86  | 91  | 95  | 96  |
|  | STD    | 0.035                      | 0.029     | 76                                 | 80  | 82  | 86  | 90  | 91  |
| Slow Whoop   | HI     | 0.098                      | 0.092     | 87                                 | 90  | 92  | 95  | 99  | 100 |
|  | STD    | 0.037                      | 0.042     | 80                                 | 84  | 87  | 90  | 94  | 95  |
| Siren  | HI     | 0.104                      | 0.092     | 86                                 | 89  | 92  | 94  | 98  | 99  |
|  | STD    | 0.036                      | 0.040     | 81                                 | 84  | 87  | 89  | 93  | 94  |
| HI/LO  | HI     | 0.057                      | 0.063     | 86                                 | 88  | 91  | 89  | 93  | 94  |
|  | STD    | 0.025                      | 0.032     | 80                                 | 84  | 86  | 84  | 88  | 89  |

| Table 4: ULC Directional Characteristics |  |
|--|--|
| -3dB                                     | +/- 35 Degrees Horizontal, +/- 35 Degrees Vertical |
| -6dB                                     | +/- 45 Degrees Horizontal, +/- 45 Degrees Vertical |

**WIRING DIAGRAMS:**

**Figure 1A: One circuit.**  
ELMTS Multi-Tone and Strobe activate in unison.

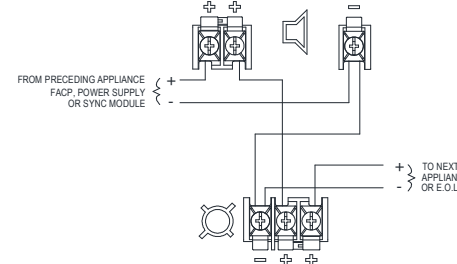

**Figure 1B: Two Circuits (Multi-Tone may be Coded)**  
ELMTS Multi-Tone and Strobe will operate independently

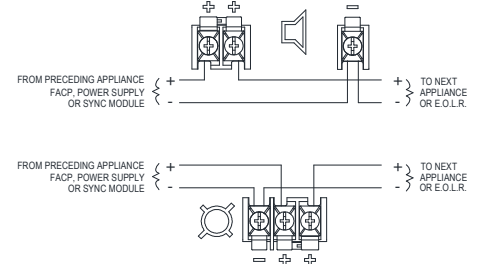

\*Refer to Dual Sync Module instruction sheets DSM (P83177) or Wheelock's Power Supplies for additional information.

**Figure 2:**



- This model has in-out wiring terminals that accept two #12 to #18 American Wire Gauge (AWG) wires at each screw terminal. Strip leads 3/8 inches and connect to screw terminals.
- Break all in-out wire runs on supervised circuits to assure integrity of circuit supervision as shown in Figure 2. The polarity shown in the wiring diagrams is for operation of the appliances. The polarity is reversed by the FACP during supervision.

**SETTINGS:** To set Volume and Tone, use Switch (SW1). Refer to Table 5,6 and Figures 3,4.

**Figure 3:** Switch (SW1) located as shown

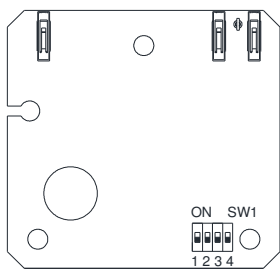

**Figure 4:** Switch (SW1) Settings

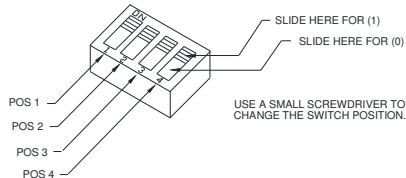

| Sound Output Level | Switch SW1 Settings              |
|--------------------|----------------------------------|
| High dBA           | SW1 POS 1 on 1 (Factory Setting) |
| Standard dBA       | SW1 POS 1 on 0                   |

**Table 6: Alarm Tone Settings**

| Tone            | Pattern Description                            | Switch (SW1) |       |       |
|-----------------|--|--------------|-------|-------|
|                 |  | POS 2        | POS 3 | POS 4 |
| Horn**          | Broadband Horn (Continuous)                    | 1            | 1     | 1     |
| Bell            | 1560 Hz Modulated (0.07 Sec. ON/Repeat)        | 1            | 0     | 1     |
| March Time Horn | Horn (0.25 Sec. ON/0.25 Sec. OFF/Repeat)       | 0            | 0     | 1     |
| Code 3 Horn     | Horn (ANSI S3.41 Temporal Pattern)             | 1            | 1     | 0     |
| Code 3 Tone     | 500 Hz (ANSI S3.41 Temporal Pattern)           | 0            | 1     | 1     |
| Slow Whoop      | 500-1200Hz Sweep (4 sec ON/0.5 sec OFF/Repeat) | 0            | 1     | 0     |
| Siren           | 600-1200Hz Sweep (1.0 Sec. ON/Repeat)          | 1            | 0     | 0     |
| HI/LO           | 1000/800 Hz (0.25 Sec. ON/Alternate)           | 0            | 0     | 0     |

\*\* Factory setting is Horn with Switch SW1 POS 2, 3, 4 set on 1, 1, 1.

The Code 3 Horn and Code 3 Tone incorporate the temporal pattern specified by ANSI/NFPA/ISO for standard emergency evacuation signaling. They shall be used only for fire evacuation signaling and not for any other purpose.

The Horn and Bell Tones can be used on coded systems with a minimum On-Time of 1/4 second. All other tones are recommended for use only on continuous (non-coded) systems.

The ELMT must be set for Code 3 horn when used with the sync module. Refer to instruction sheets for DSM (P83177) or Wheelock power supplies for additional information.

**SETTINGS:** To set candela, slide the selector switch to the desired setting. See Figure 5.

**Figure 5: Candela**

Set from side or rear. Factory Setting is 15cd.

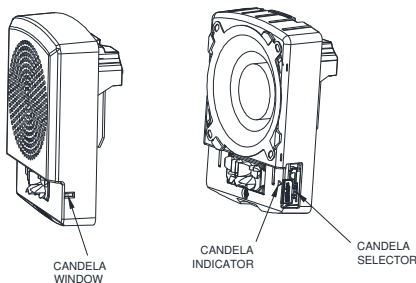

Strobe device has only one mounting orientation. LED light element should be oriented toward the floor  
NFPA 72/ANSI 117.1 provide means for determining equivalent illumination using fewer, higher intensity strobes within the protected area.

**Figure 7: Grille Removal \*\***

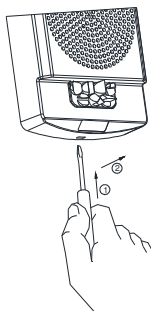

**Figure 6: ELMTS Light Distribution**

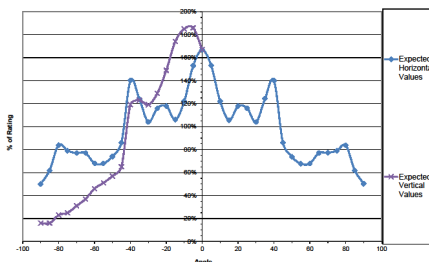

**Figure 8: Surface BackBox - ELSPKBB**

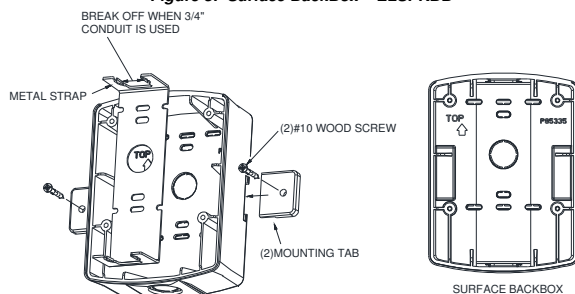

**MOUNTING OPTIONS:**

The following figures (A and B) show the maximum number of field wires (conductors) that can enter the backbox used with each mounting option. If these limits are exceeded, there may be insufficient space in the backbox to accommodate the field wires and stresses from the wires could damage the product.

Check that the installed product will have sufficient clearance and wiring room prior to installing backboxes and conduit, especially if sheathed multiconductor cable or 3/4" conduit fittings are used.

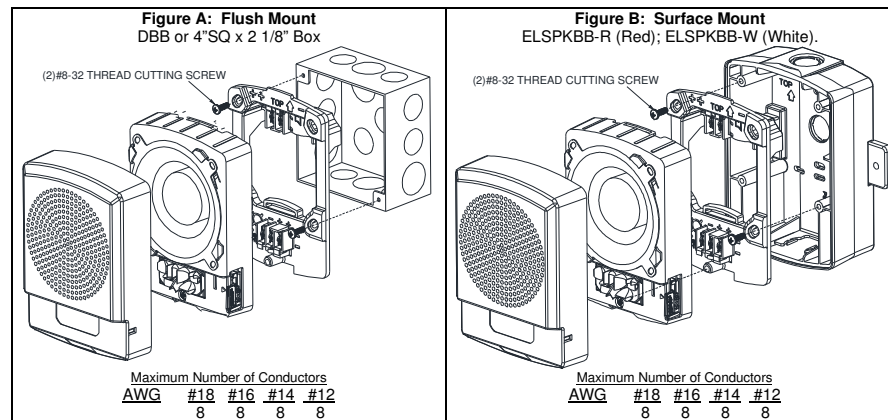

**All installations shall be in accordance with:**

- 1) In the United States, the National Electrical Code, NFPA 70, and the National Fire Alarm and Signaling Code, NFPA 72.
- 2) In Canada, CSA C22.1, Canadian Electrical Code, Part I, Safety Standard for Electrical Installations, Section 32; and the Canadian Standard for the Installation of Fire Alarm Systems - CAN/ULC-S524.

**MOUNTING PROCEDURES:**

1. Select a mounting option and install the backbox. ELSPKBB requires 5 1/8" spacing for surface mounting. Screws are provided. Conduit entrances to the backbox should be selected to provide sufficient wiring clearance for the installed product. Do not pass additional wires (used for other than the signaling appliance) through the backbox. Such additional wires could result in insufficient wiring space for the signaling appliance.
2. Install the Mounting Plate on the backbox. Use 8-32 screws for 4" back-box or hi-lo screws for the ELSPKBB.
3. Pre-Wire: Connect field wires to terminals on mounting plate (reference Figure 1 and 2). Use care and proper techniques to position the field wires in the backbox so that they use minimum space and produce minimum stress on the product. This is especially important for stiff, heavy gauge wires and wires with thick insulation or sheathing. When terminating field wires, do not use more lead length than required. Excess lead length could result in insufficient wiring space for the signaling appliance.
4. Pre-Test: Mounting Plate contains a SHUNT between adjacent "+" terminals to facilitate testing before device is attached. Note: Shunt will open permanently when device is installed on mounting plate.
5. Verify appliance settings are correct for your application. Settings are shown in Fig. 3-5. Factory settings are HIGH dBA, Horn, 15cd.
6. Place the Eluxa appliance over the mounting plate. Engage TOP hook on mounting plate, then secure with screw at the bottom. Use care to prevent speaker cone damage when driving the screw.
7. Align cover to the Eluxa appliance with strobe opening over LED lens. Then, snap the cover in place.
8. To remove the appliance, insert a small flat-bladed screwdriver into the bottom opening 1/2" as shown in Figure 7. Then lift off grille.
9. Accessories for Eluxa surface back box (Ceiling): ELSPKBB-R (Red); ELSPKBB-W (White).

**Important: Do not fully back out terminal screws. Do not over tighten screws or terminals. Excessive torque may affect operation. When using power tools, ensure the torque is set to the lowest setting available.**

NOTE: Final acceptance is subject to Authorities Having Jurisdiction.

Check the installation instructions of the manufacturers of other equipment used in the system for any guidelines or restrictions on wiring and/or locating Notification Appliance Circuits (NAC) and notification appliances. Some system communication circuits and/or audio circuits, for example, may require special precautions to assure immunity from electrical noise (e.g. audio crosstalk).

This equipment has been tested and found to comply with the limits for a Class A digital device, pursuant to part 15 of the FCC Rules. These limits are designed to provide reasonable protection against harmful interference when the equipment is operated in a commercial environment. This equipment generates, uses, and can radiate radio frequency energy and, if not installed and used in accordance with the instruction manual, may cause harmful interference to radio communications. Operation of this equipment in a residential area is likely to cause harmful interference in which case the user will be required to correct the interference at his own expense.

This Class A digital apparatus meets all requirements of the Canadian Interference-Causing Equipment Regulations. Cet appareil numérique de la classe A respecte toutes les exigences du Règlement sur le matériel brouilleur du Canada.

Any material extrapolated from this document or from Cooper Wheelock manuals or other documents describing the product for use in promotional or advertising claims, or for any other use, including description of the product's application, operation, installation and testing is used at the sole risk of the user and Cooper Wheelock will not have any liability for such use. IN NO CASE WILL SELLER'S LIABILITY EXCEED THE PURCHASE PRICE PAID FOR A PRODUCT.

\*\* Grille removal: (Figure 7) 1) Insert Screwdriver into slot, and push to release snap. 2) Lift Up to remove the grille.