



BP-VRTEXL Series Battery Packs

User's Manual

Para Systems, Inc.
1455 Lemay Dr.
Carrollton, TX 75007
Phone: 1-972-446-7363
Fax: 1-972-446-9011
Internet: minutemanups.com
UPS Sizing: sizemyups.com

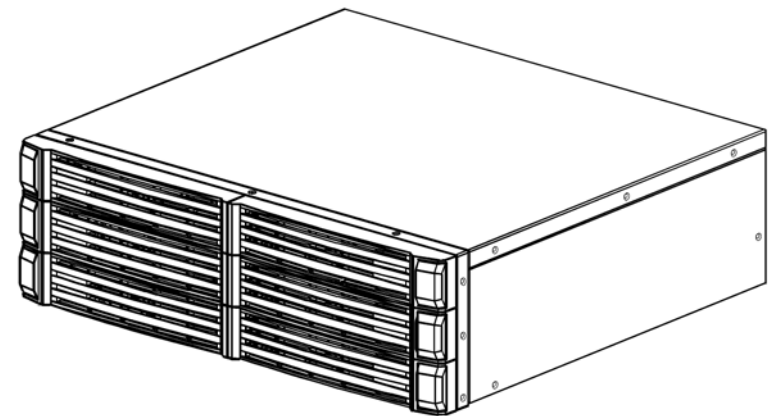

TABLE OF CONTENTS

1.	Introduction	2
2.	Rear Panel	6
3.	Installation	6
4.	Operation	12
5.	Obtaining Service	14
6.	Replacing the Battery	15
7.	Specifications	18
8.	Limited Product Warranty	19

Chapter 1: Introduction

Thank you for purchasing this power protection product. It has been designed and manufactured to provide many years of trouble free service. Please read this manual before installing your BP-VRTEXL Battery Pack series, models BP24V72RTEXL, BP36V48RTEXL, BP48V36RTEXL, BP72V24RTEXL as it provides important information that should be followed during the installation and the maintenance of the Battery Pack and batteries allowing you to correctly set up your system for the maximum safety and performance. Included is information on customer support and factory service, if it is required. If you experience a problem with the Battery Pack please refer to the Obtaining Service section in this manual to correct the problem or collect enough information so that the Technical Support Department can assist you.

SAVE THESE INSTRUCTIONS - This manual contains important instructions that should be followed during the installation and the maintenance of the Battery Pack and the batteries.

IMPORTANT SAFETY INSTRUCTIONS
SAVE THESE INSTRUCTIONS !
CONSIGNES DE SÉCURITÉ IMPORTANTES
SAUVEGARDEZ CES CONSIGNES!

Veuillez lire ce manuel avant l'installation de l'onduleur modèles BP24V72RTEXL, BP36V48RTEXL, BP48V36RTEXL, BP72V24RTEXL. Il contient de l'information importante qui doit être respectée au cours de l'installation et de l'entretien de l'onduleur et des batteries. Cette information vous permettra de correctement installer le système pour atteindre son rendement maximum en toute sécurité.

CAUTION! The maximum ambient operating temperature for this Battery Pack series is 40°C ("0 ~ 40°C" for Ambient Operation).

- The external vents and openings on the Battery Pack are provided for ventilation. To ensure reliable operation of the Battery Pack and to protect the Battery Pack from overheating, these vents and openings must not be blocked or covered. Do not insert any object into any of the vents or opening that may hinder the ventilation.
- Install the Battery Pack in a well ventilated area, away from excess moisture, heat, dust, flammable gas or explosives.
- Leave adequate space (at least 20cm) in the front and at the rear of the Battery Pack for proper ventilation.
- Do not mount the Battery Pack with its front or rear panel facing down at any angle.
- Before usage, you must allow the Battery Pack to adjust to room temperature (20°C~25°C or 68°F~77°F) for at least one hour to avoid moisture condensing inside the Battery Pack.

CAUTION! This Battery Pack series is **ONLY** intended to be installed in an indoor temperature controlled environment that is free of conductive contaminants. This Battery Pack series is not intended for use in a computer room as defined in the Standard for the Protection of Electronic Computer/Data Processing Equipment ANSI/NFPA 75.

CAUTION! Connect the Battery Pack to a two pole, three wire grounded AC wall outlet. The receptacle must be connected to the appropriate branch protection (circuit breaker or fuse). Connection to any other type of receptacle may result in a shock hazard and violate local electrical codes. **DO NOT PLUG THE BATTERY PACK INTO EXTENSION CORDS, ADAPTER PLUGS OR SURGE STRIPS. DO NOT CUT THE INPUT PLUG OFF AND ATTEMPT TO HARDWIRE THIS BATTERY PACK, DOING SO WILL VOID THE WARRANTY.**

CAUTION! To reduce the risk of fire, connect only to a utility powered circuit provided with 20 amperes maximum branch circuit over-current protection in accordance with the National Electric Code, ANSI/NFPA 70.

CAUTION! To reduce the risk of electrical shock with the installation of this Battery Pack and UPS equipment, the user must ensure that the combined sum of the AC leakage current does not exceed 3.5mA.

CAUTION! To reduce the risk of electrical shock in conditions where the load equipment grounding cannot be verified, disconnect the Battery Pack and the UPS from the AC wall outlet before installing a computer interface cable. Reconnect the power cord only after all signaling connections are made.

WARNING: This Battery Pack contains potentially hazardous voltages. Do not attempt to disassemble the Battery Pack beyond the battery replacement procedure. This Battery Pack contains no user serviceable parts. Repairs and Battery replacement must be performed by **QUALIFIED SERVICE PERSONNEL ONLY**.

WARNING: Qualified Service Personnel ONLY must perform the Installation and Servicing of these Battery Packs. MINUTEMAN accepts no liabilities and is not limited to: injury to the Service Personnel, or damages to; the Battery Pack and the UPS, or the connected equipment caused by the incorrect installation or servicing of the Battery Pack.

WARNING: Risk of Electrical Shock. Hazardous live parts inside these Battery Packs are energized from the battery even when the AC input is disconnected.

CAUTION! DO NOT USE THE MOUNTING BRACKETS TO LIFT THE BATTERY PACK. The mounting brackets are **ONLY** for securing the Battery Pack to the rack.

CAUTION! To de-energize the Battery Pack:

1. If the UPS is On press and release the On/Off/Test button.
2. Disconnect the UPS and the Battery Pack from the AC wall outlet.
3. Turn off the DC breaker on the rear panel of the Battery Pack.
4. Disconnect the battery cable from the rear panel of the UPS.
5. To de-energize the Battery Pack completely, disconnect the batteries.

WARNING: Qualified Service Personnel ONLY must perform the Installation and Servicing of these Battery Packs. MINUTEMAN accepts no liabilities and is not limited to: injury to the Service Personnel, or damages to; the Battery Pack, the UPS, or the connected equipment caused by the incorrect installation or servicing of the Battery Packs. These Battery Packs MUST be operated with their respective UPS models, see the table below:

BP Model	BP24V72RTEXTL	BP36V48RTEXTL	BP48V36RTEXTL	BP72V24RTEXTL
UPS Model	ED1000RMT2U ED1000RTXL2U	E750RTXL2U E1000RTXL2U E1500RTXL2U E1500RTXL2U	ED1500RMT2U ED2000RMT2U ED1500RTXL2U ED2000RTXL2U	E2000RTXL2U E3000RTXL2U E3000RTXL2U ED3000RMT2U ED3000RTXL2U

RECEIVING INSPECTION

Once you receive the product it should be visually inspected for damage that may have occurred in shipping. Immediately notify the carrier and place of purchase if any damage is found. Warranty claims for damage caused by the carrier will not be honored by the manufacturer. The packing materials that the product was shipped in were carefully designed to minimize any shipping damage. In the unlikely case that the product needs to be returned to the manufacturer, use the original packing material. Since the manufacturer is not responsible for shipping damage incurred when the product is returned, the original packing material is inexpensive insurance. **PLEASE SAVE THE PACKING MATERIALS!**



Life Support Policy

As a general policy, we do not recommend the use of any of our products in life support applications where failure or malfunction of the product can be reasonably expected to cause failure of the life support device or to significantly affect its safety or effectiveness. We do not recommend the use of any of our products in direct patient care. We will not knowingly sell our products for use in such applications unless it receives in writing assurances satisfactory to us that (a) the risks of injury or damage have been minimized, (b) the customer assumes all such risks, and (c) our liability is adequately protected under the circumstances.

© COPYRIGHT 2019 BY PARA SYSTEMS, INC.

All Rights Reserved. All rights of this User Manual ("Manual"), including but not limited to the content, information, and figures are solely owned and reserved by Para Systems, Inc. ("Para Systems"). The Manual can only be applied to the operation or the use of this product. Any disposition, duplication, dissemination, reproduction, modification, translation, extraction, or usage of this Manual in whole or in part is prohibited without the prior written permission of Para Systems. Given that Para Systems will continuously improve and develop the product, changes may be made to the information in this Manual at any time without obligation to notify any person of such revision or changes. Para Systems will make all possible efforts to secure the accuracy and the integrity of this Manual. Para Systems disclaims any kinds or forms of warranty, guarantee, or undertaking, either expressly or implicitly, including but not limited to the completeness, faultlessness, accuracy, non-infringement, merchantability or fitness for a particular purpose of the Manual.

Chapter 2: Rear Panel

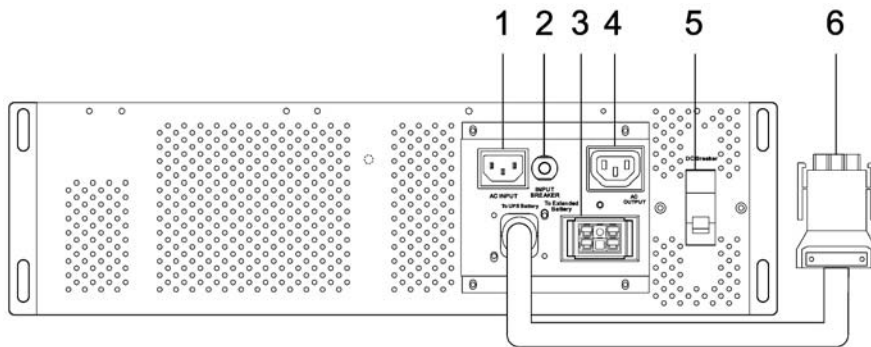

1. The AC Inlet is for connecting the input power cord to the AC wall outlet to operate the Charger.
2. The Input Breaker will trip in the event that the Internal Charger draws excessive current.
3. The External Battery connector is for Daisy Chaining additional Battery Packs.
4. The AC Outlet is for connecting the AC output cable to Daisy Chain additional Battery Packs.
5. The DC Breaker connects and disconnects the DC bus voltage from the Battery Pack to the UPS. The DC Breaker will trip in the event of a DC over-current condition.
6. The External Battery cable is for connecting the Battery Pack to the UPS or to Daisy Chain additional Battery Packs.

Chapter 3: Installation

INSTALLATION PLACEMENT

ENVIRONMENTAL	
Operating Temperature (max)	0 to 40°C (+32 to +104°F)
Storage Temperature	-15 to +45°C (+5 to +113°F)
Operating/Storage Humidity	10% - 90% Non-Condensing
Operating Elevation	0 to 3,000m (0 to +10,000 ft)
Storage Elevation	0 to 15,000m (0 to +50,000 ft)
Audible Noise at 1 m (3 ft.)	<45 dBA

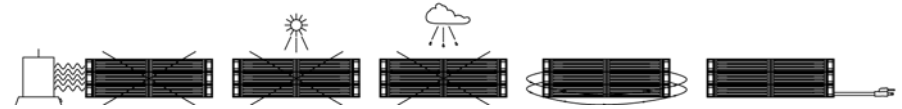

This Battery Pack series is **ONLY** intended to be installed in an indoor temperature controlled environment that is free of conductive contaminants. DO NOT operate the Battery Pack in: extremely dusty and/or unclean areas, locations near heating devices, water or excessive humidity, or where the Battery Pack is exposed to direct sunlight. Select a location, which will provide good air circulation for the Battery Pack at all times. Route cables so they cannot be walked on or damaged. This Battery Pack series is not for use in a computer room as defined in the Standard for the Protection of Electronic Computer/Data Processing Equipment ANSI/NFPA 75. Typical battery life is 3 to 5 years. Environmental factors do affect battery life. High temperatures, poor ventilation and frequent, short duration discharges have a negative impact on battery life.

INSTALLATION

Be sure to read the installation placement and all the cautions before installing the Battery Pack. Place the Battery Pack in the final desired location and complete the rest of the installation procedure.

CAUTION! DO NOT USE THE MOUNTING BRACKETS TO LIFT THE BATTERY PACK. The mounting brackets are **ONLY** for securing the Battery Pack to the rack.

WARNING! These Battery Packs are extremely heavy. Any time the Battery Pack has to be handled be sure to use, enough personnel, strong supports and equipment to safely handle the Battery Pack.

CAUTION! Before connecting the Battery Pack to the AC wall outlet, verify that the AC source is 120VAC. Use a two pole, three wire, grounded AC wall outlet. The AC wall outlet shall be near the Battery Pack and shall be easily accessible. The input power cord on this Battery Pack series is intended to serve as a disconnect device. **DO NOT PLUG THE BATTERY PACK INTO EXTENSION CORDS, ADAPTER PLUGS OR SURGE STRIPS. DO NOT CUT THE INPUT PLUG OFF AND ATTEMPT TO HARDWIRE THIS BATTERY PACK, DOING SO WILL VOID THE WARRANTY.**

NOTE: When using these Battery Packs, the UPS must be configured so that the UPS will report the correct estimated runtime on the LCD screen and in the Power Monitoring software and/or the SNMP card. See the Power Monitoring software or the SNMP card's User's Manual to configure the UPS.

RACKMOUNT CONFIGURATION

The Battery Pack comes with mounting brackets and rails for the standard 19" (46.5cm) 4-post rack. The screws for mounting the Battery Pack to the rack are not included (screw size varies with rack size).

1. Mount the rails to the 4-post rack. (FIG. 1)
2. Locate the mounting bracket screw holes on the side panels of the Battery Pack, at the front of the Battery Pack. (FIG. 2)
3. Align the mounting bracket with the mounting bracket screw holes. (FIG. 2)
4. Attach the mounting bracket with the retaining screws. (FIG. 2)
5. Install the Battery Pack onto the Rails and secure the Battery Pack to the rack with the retaining screws. (FIG. 3) **WARNING:** Use two or more people when installing the Battery Pack. Use **CAUTION**, the Battery Pack is extremely heavy. Do not move the rack after the units have been installed. The rack may be unstable due to the weight distribution.
6. The Rackmount Configuration is complete. See Connecting the Battery Pack.

FIG. 1

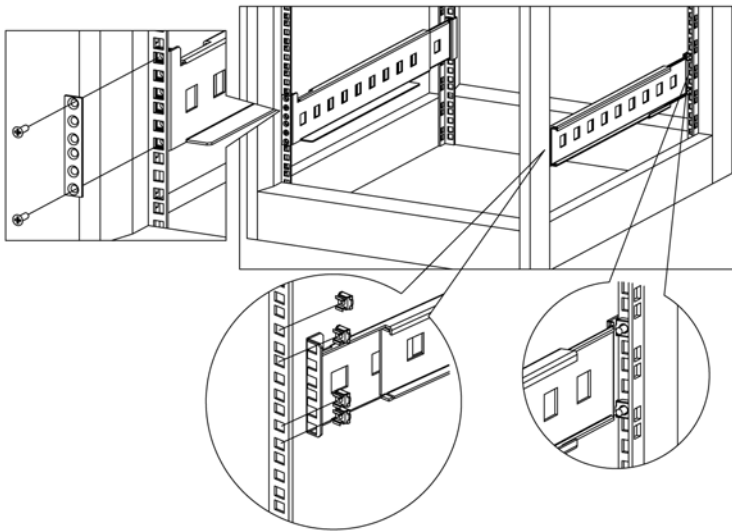

FIG. 2

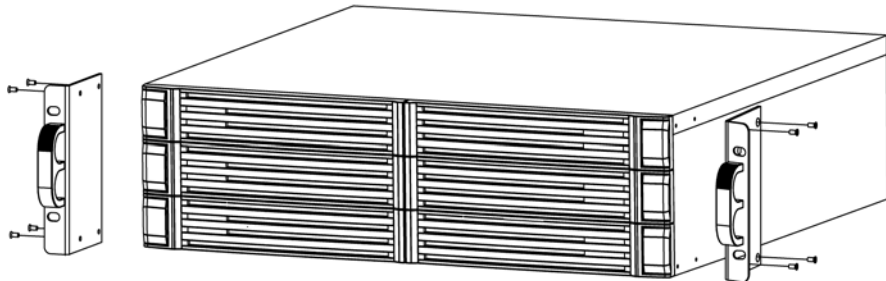
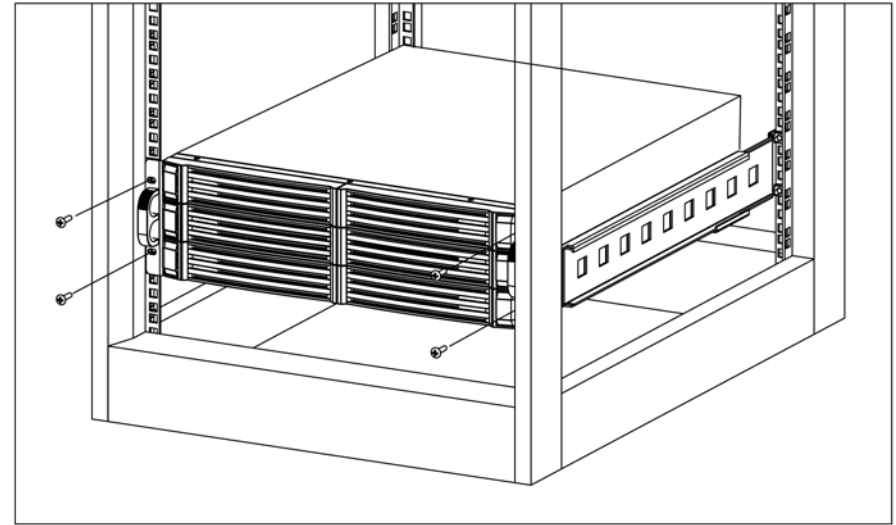

FIG. 3



TOWER CONFIGURATION

The tower configuration allows the user to install the Battery Pack in the up-right position next to the UPS. The tower brackets are provided with the Battery Pack. **WARNING:** Use two or more people when installing the Battery Pack. Use **CAUTION**, the Battery Pack is extremely heavy.

1. Once the location of the Battery Pack has been determined, lay the Battery Pack on its side. (FIG. 1)
2. Attached the tower brackets to the Battery Pack with the retaining screws. (FIG. 1)
3. Rotate the Battery Pack to the up-right position. Ensure the Battery Pack is stable. (FIG. 2)
4. The Tower Configuration is complete. See Connecting the Battery Pack.

FIG. 1

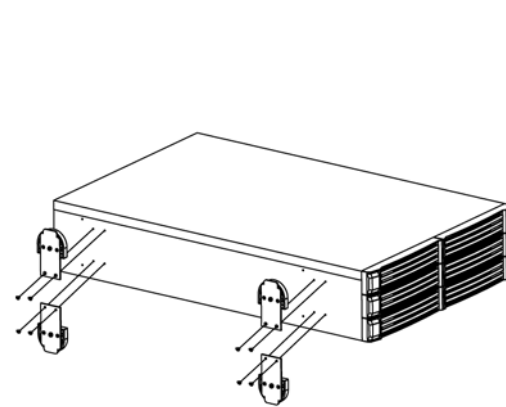
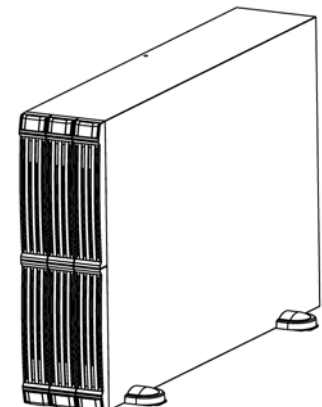

FIG. 2



CAUTION! Before connecting the Battery Pack to the AC wall outlet, verify that the AC source is 120VAC. Use a two pole, three wire, grounded AC wall outlet. The AC wall outlet shall be near the Battery Pack and shall be easily accessible. The input power cord on this Battery Pack series is intended to serve as a disconnect device. **DO NOT PLUG THE BATTERY PACK INTO EXTENSION CORDS, ADAPTER PLUGS OR SURGE STRIPS. DO NOT CUT THE INPUT PLUG OFF AND ATTEMPT TO HARDWIRE THIS BATTERY PACK, DOING SO WILL VOID THE WARRANTY.**

CONNECTING THE BATTERY PACK
(QUALIFIED SERVICE PERSONNEL ONLY)

1. Be sure to read the installation placement procedure, all of the cautions and the safety precautions before connecting the Battery Pack(s).
2. Make sure that the DC circuit breaker on the rear panel of the Battery Pack is in the Off position. **CAUTION:** If the Battery Pack's DC circuit breaker is in the On position, the battery voltage will be present at the open end of the Battery Pack's external battery cable and external battery connector.
3. Make sure that the Battery Pack's input power cord is disconnected from the AC wall outlet.
4. Turn the UPS off and disconnect the UPS's input power cord from the AC wall outlet.
5. Remove the External Battery Connector cover plate from the UPS's rear panel.
6. Verify, before connecting the Battery Pack's external battery cable into the UPS's external battery connector, that they mate red to red and black to black. **NOTE:** The red connector is the battery positive (+) and the black connector is the battery negative (-). Connect the external battery cable from the Battery Pack to the external battery connector on the UPS.
7. Plug the Battery Pack's input power cord's IEC connector into the AC Inlet on the rear panel of the Battery Pack.
8. Plug the other end of the Battery Pack's input power cord (NEMA 5-15P plug) into the AC wall outlet.
9. Turn On the DC circuit breaker on the rear panel of the Battery Pack.
10. The Battery Pack is ready for normal operation. See the UPS User' Manual for the normal startup procedure for the UPS.

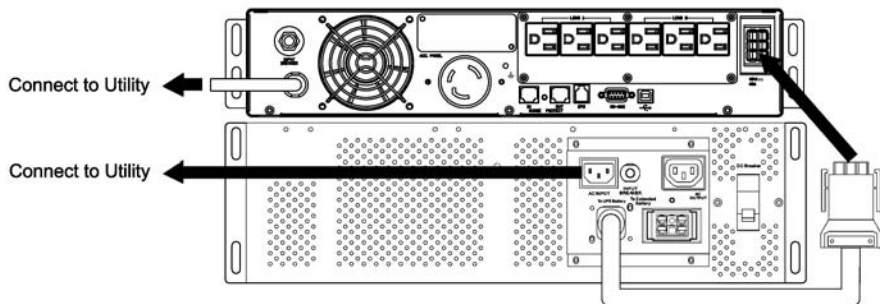

NOTE: When using these Battery Packs, the UPS must be configured so that the UPS will report the correct estimated runtime on the LCD screen and in the Power Monitoring software and/or the SNMP card. See the Power Monitoring software or the SNMP card's User's Manual to configure the UPS.

Model	This is the number of External Battery Packs to select in the power monitoring software and/or the SNMP card for each Battery Pack.
BP24V72RTEXTL	4
BP36V48RTEXTL	3
BP48V36RTEXTL	2
BP72V24RTEXTL	3

DAISY CHAINING
(QUALIFIED SERVICE PERSONNEL ONLY)

"Daisy Chaining" means connecting one Battery Pack to another Battery Pack to another Battery Pack, this chain could go on indefinitely. Follow the steps below to Daisy Chain the Battery Packs:

1. Be sure to read the installation placement procedure, all of the cautions and the safety precautions before Daisy Chaining the Battery Pack(s).
2. Make sure that the DC circuit breakers on the rear panel of the Battery Packs are in the Off position. **CAUTION:** If the Battery Pack's DC circuit breaker is in the On position, the battery voltage will be present at the open end of the Battery Pack's external battery cable and external battery connector.
3. Make sure that the Battery Pack's input power cord is disconnected from the AC wall outlet.
4. Turn the UPS off and disconnect the UPS's input power cord from the AC wall outlet.
5. Remove the external battery connector's cover plate from the UPS's rear panel and the additional Battery Packs rear panel.
6. Verify, before connecting the Battery Pack's external battery cable into the UPS's external battery connector, that they mate red to red and black to black. **NOTE:** The red connector is the battery positive (+) and the black connector is the battery negative (-).
7. Connect the external battery cable from the first Battery Pack to the external battery connector on the UPS.
8. Connect the external battery cable from the second Battery Pack to the external battery connector on the first Battery Pack.
9. Connect the Daisy Chain power cord (IEC to IEC connectors) from the AC Outlet of the of the first Battery Pack to the AC Inlet of the second Battery Pack.

10. Plug the Battery Pack's input power cord's IEC connector into the AC Inlet on the rear panel of the first Battery Pack.
11. Plug the other end of the Battery Pack's input power cord (NEMA 5-15P plug) into the AC wall outlet.
12. Turn On the DC circuit breakers on the rear panel of all of the Battery Packs.
13. The Battery Packs are ready for normal operation, see the UPS User's Manual for the normal startup procedure for the UPS.

NOTE: There is no maximum number for Daisy Chaining the DC bus voltage for the Battery Packs. The maximum number that can be Daisy Chained for the AC source is five Battery Packs.

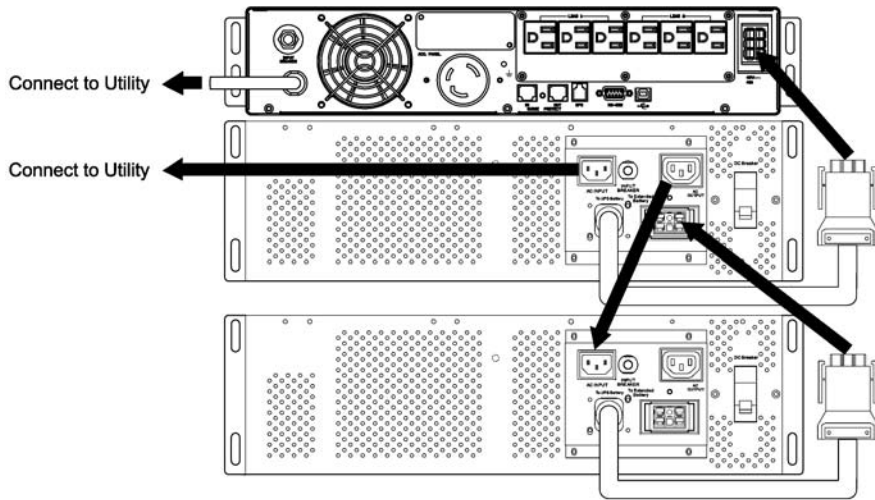

Chapter 4: Operation

SYSTEM OVERVIEW

These Battery Packs will extend the runtime capabilities of the UPS. These Battery Packs have internal chargers to properly maintain the internal batteries. The Battery Pack will charge the batteries with the DC breaker in the On or Off position as long as the Battery Pack is plugged into the AC wall outlet and there is an acceptable AC voltage present. When the commercial power is lost the charger will turn Off and the Battery Pack will extend the runtime of the UPS. When the commercial power returns the Battery Pack's internal charger will automatically start recharging the batteries. During normal AC operation, the UPS and Battery Pack will quietly and confidently protect your system from power anomalies.

Block Diagram of the Basic Wiring and Internal Circuit Configuration

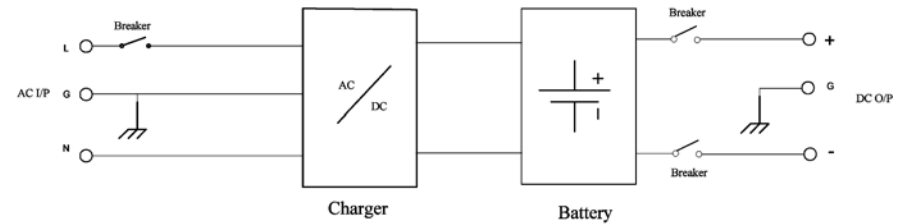

TURNING THE BATTERY PACK ON/OFF

Turning the DC circuit breaker to the On position will connect the DC bus voltage from the Battery Pack to the UPS. Turning the DC circuit breaker to the Off position will disconnect the DC bus voltage from the Battery Pack to the UPS. The DC circuit breaker does NOT turn on or turn off the internal charger. Plug the Battery Pack's AC input power cord into the AC wall outlet to turn on the internal charger. Unplug the Battery Pack's AC input power cord from the AC wall outlet to turn off the internal charger.

CHARGING THE BATTERY

The Battery Pack will charge the internal batteries whenever the Battery Pack is connected to an AC source and there is an acceptable AC voltage (75 - 140VAC) present. It is recommended that the Battery Packs be charged for a minimum of 4 hours before use. The Battery Pack may be used immediately, however, the "On-Battery" runtime of the UPS may be less than normally expected. **NOTE:** If the Battery Pack is going to be out of service or stored for a prolonged period of time, the batteries must be recharged for at least 24 hours every ninety days.

NOTE: When using these Battery Packs, the UPS must be configured so that the UPS will report the correct estimated runtime on the LCD screen and in the Power Monitoring software and/or the SNMP card. See the Power Monitoring software or the SNMP card's User's Manual to configure the UPS.

Model	This is the number of External Battery Packs to select in the power monitoring software and/or the SNMP card for each Battery Pack.
BP24V72RTEXTL	4
BP36V48RTEXTL	3
BP48V36RTEXTL	2
BP72V24RTEXTL	3

Chapter 5: Obtaining Service

IF THE BATTERY PACK REQUIRES SERVICE

1. Use the following to eliminate obvious causes.
2. Verify there are no tripped circuit breakers and that the batteries are good. A tripped circuit breaker and defective batteries are the most common issues.
3. Call your dealer for assistance. If you cannot reach your dealer, or if they cannot resolve the issue call the Technical Support department at (972) 446-7363, or visit our Web site at www.minutemanups.com and look under the Support Tab. Before calling the Technical Support Department have the following information available:
 - a) Contact name and address.
 - b) Where and when the unit was purchased.
 - c) All of the model information about your unit.
 - d) The serial number of your unit.
 - e) Any information on the failure, including LEDs that may be illuminated or error codes displayed.
 - f) A description of the protected equipment including model numbers, if possible.
 - g) A technician will ask you for the above information and if possible, help solve the issue over the phone. In the event that the unit requires factory service, the Technical Support Representative will issue you a Return Material Authorization Number (RMA #). **NOTE: We must have the model number and the serial number of the product to issue an RMA #.**
 - h) If the unit is under warranty, the repairs will be done at no charge. If the unit is not under warranty there will be a charge for the repair.
4. Pack the unit in its original packaging. If the original packaging is no longer available, ask the Technical Support Representative about obtaining a new set. It is important to pack the unit properly in order to avoid damages during transit. Never use Styrofoam beads for a packing material.
 - a) Include a letter with your name, address, daytime phone number, the RMA number, a copy of your original sales receipt, and a brief description of the problem.
5. Mark the RMA # on the outside of all packages. The factory cannot accept any package without the RMA # marked on the outside.
6. Return the unit by insured, prepaid carrier to:

Para Systems Inc.
 MINUTEMAN UPS
 1809 W. Frankford Road, Suite 150
 Carrollton, TX 75007
 ATTN: RMA# _____

Chapter 6: Replacing The Battery

(QUALIFIED SERVICE PERSONNEL ONLY)

These Battery Packs have an easy to replace hot-swappable batteries. Please read all of the **WARNINGS** and **CAUTIONS** before attempting to service the batteries.

NOTE: If there is a power interruption while replacing the hot-swappable batteries, with the UPS on, the load will not be backed up.

WARNING! These Battery Packs contain potentially hazardous voltages. Do not attempt to disassemble the Battery Pack beyond the battery replacement procedure. These Battery Packs contain no user serviceable parts. Repairs and Battery replacement must be performed by **QUALIFIED SERVICE PERSONNEL ONLY**.

CAUTION: Do not open or mutilate batteries. Released electrolyte is harmful to the skin and eyes and may be toxic.

CAUTION: Do not dispose of batteries in a fire. The batteries may explode. The batteries in these Battery Packs are recyclable. Dispose of the batteries properly. The batteries contain lead and pose a hazard to the environment and human health if not disposed of properly. Refer to local codes for proper disposal requirements or return the battery to the supplier.

CAUTION: Although battery system voltages are only 24VDC, 36VDC, 48VDC and 72VDC the battery system can still present a risk of electrical shock. These batteries produce sufficient current to burn wire or tools very rapidly, producing molten metal. Observe these precautions when replacing the batteries:

1. Remove watches, rings, or other metal objects.
2. Use hand tools with insulated handles.
3. Wear protective eye gear (goggles), rubber gloves and boots.
4. Do not lay tools or other metal parts on top of batteries.
5. Disconnect the charging source prior to connecting or disconnecting the battery terminals.
6. Determine if the battery is inadvertently grounded. If the battery is, remove the source of the grounding. Contact with any part of a grounded battery can result in an electrical shock. The likelihood of such shock will be reduced, if such grounds are removed during installation and maintenance.

CAUTION: Replace the batteries with the same number and type as originally installed in the Battery Pack. These batteries have pressure operated vents. These Battery Packs contain sealed non-spillable maintenance free lead acid batteries.

Model #	BP24V72RTEXTL	BP36V48RTEXTL	BP48V36RTEXTL	BP72V24RTEXTL
Battery Module #	BM0082	BM0083	BM0084	BM0085
Battery Qty/Rating	12 - 12V12Ah			
CSB Part #	GP 12120 F2			

BATTERY REPLACEMENT PROCEDURE

(QUALIFIED SERVICE PERSONNEL ONLY)

PLEASE READ THE CAUTIONS AND WARNINGS BEFORE ATTEMPTING TO REPLACE THE BATTERIES

Hot-swappable batteries mean that the batteries can be replaced without powering down the whole UPS system.

NOTE: If there is a power interruption while replacing the hot-swappable batteries, with the UPS on, the load will not be backed up. To hot-swap the Battery Pack's batteries start with step number 6.

1. Turn off the equipment that is plugged into the output receptacles of the UPS.
2. Press and release the Off button on the front panel to turn the UPS off.
3. Unplug the UPS's AC power cord from the AC wall outlet.
4. Unplug the equipment from the output receptacles of the UPS.
5. Unplug the computer interface cable from the rear panel of the UPS.
6. Turn off all of the DC circuit breakers on the rear panel of all of the Battery Packs.
7. Unplug all of the Battery Pack's AC power cords from the AC wall outlet.
8. Disconnect all of the external battery cables.
9. Remove the six (6) front panel retaining screw cover plates. (FIG. 1)

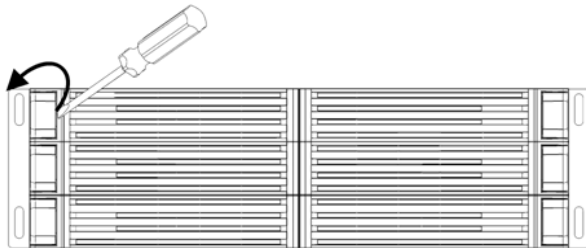
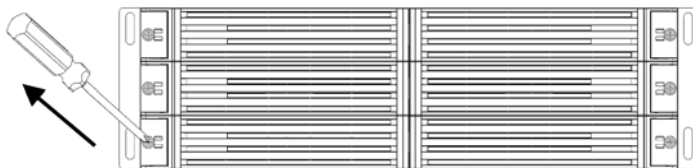

FIG. 1

10. Remove the six (6) front panel retaining screws. (FIG. 2)
11. Remove the front panel.

FIG. 2



12. Remove the two (2) retaining screws for the battery retaining bracket. (FIG. 3)
13. Remove the battery retaining bracket.

FIG. 3

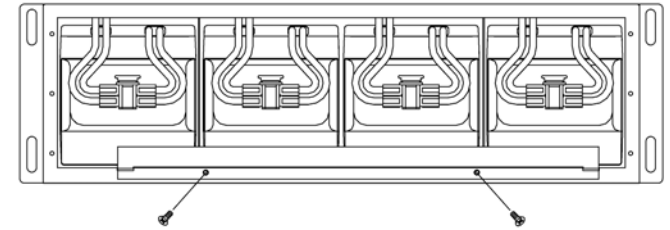

14. Press down to unlock the battery connector holders, one on each battery module. (FIG. 4)
15. Disconnect the battery connectors (red and black) one on each battery module. (FIG. 4)
16. Grasp the battery pull tabs and gently pull the battery modules out of the Battery Pack one at a time and set on the floor. (FIG. 4)

FIG. 4

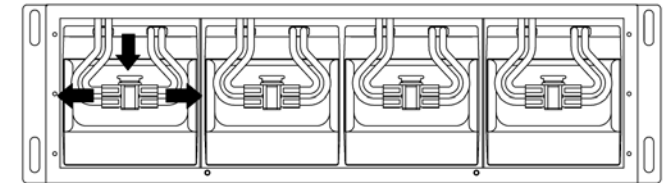

NOTE: Use Caution, the battery modules are heavy.

17. Slide the new battery modules into the Battery Pack one at a time.
18. Verify proper polarity. Reconnect the battery connectors (red and black).
- NOTE:** Some sparking might occur, this is normal.
19. Press the battery connectors into the battery connector holders, one on each battery module and lock them in place.
20. Re-install the battery retaining bracket.
21. Re-install the two (2) retaining screws for the battery retaining bracket.
22. Re-install the front panel on the Battery Pack.
23. Re-install the six (6) front panel retaining screws.
24. Re-install the six (6) front panel retaining screw cover plates.
25. Reconnect all of the external battery cables.
26. Reconnect all of the the Battery Pack's AC power cords to the AC wall outlet.
27. Turn on all of the DC circuit breakers on the rear panel of all of the Battery Packs.
28. Properly dispose of the old batteries at an appropriate recycling facility or return them to the supplier in the packing material for the new batteries.
29. The Battery Pack is ready for normal operation.

NOTE: If the UPS has a Weak/Bad Battery Alarm after replacing the batteries, the user must initiate a self test to clear the Weak/Bad Battery Alarm. To initiate a self test see section 4 "**SELF TEST**" in the UPS's User's Manual.

Chapter 7: Specifications

SYSTEM SPECIFICATIONS				
Model Number	BP24V72RTEXTL	BP36V48RTEXTL	BP48V36RTEXTL	BP72V24RTEXTL
Format	Rack/Tower Convertible			
CHARGER INPUT				
Number of Phases	Single (1Ø 2W +G)			
Nominal Voltage	120VAC			
Voltage Range	75 - 140VAC			
AC Current	2.5 Amps			
Frequency Limits	44 - 66 Hz			
Input Protection	Resettable Circuit Breaker			
Surge Energy Rating	220Joules			
Input Power Cord	IEC320 C13 to NEMA 5-15P, 10ft			
Daisy Chain Power Cord	IEC320 C13 to IEC320 C14, 6ft			
CHARGER OUTPUT				
DC Voltage	27.3VDC ±1%	41.0VDC ±1%	54.6VDC ±1%	81.9VDC ±1%
DC Current	5Amps ±15%	4Amps ±15%	3Amps ±15%	2Amps ±15%
BATTERY SYSTEM				
Battery Type	Sealed, Non-Spillable, Maintenance Free, Value Regulated, Lead Acid			
Typical Recharge Time	10-hours to 90% after full load discharge			
Typical Battery Life	3-5 years, depending on discharge cycles and ambient temp			
System Voltage	24VDC	36VDC	48VDC	72VDC
Battery Module	BM0082	BM0083	BM0084	BM0085
Battery Qty/Rating	12 / 12V12Ah			
ENVIRONMENTAL				
Operating Temperature	0 to 40°C (+32 to +104°F)			
Storage Temperature	-15 to +45°C (+5 to +113°F)			
Oper/Storage Humidity	10% - 90% Non-Condensing			
Operating Elevation	0 to 3,000m (0 to +10,000 ft)			
Storage Elevation	0 to 15,000m (0 to +50,000 ft)			
PHYSICAL				
Size - Net (LxWxH)	26.8 x 17.3 x 5.2" / 680 x 440 x 132 mm			
Weight - Net	131.2 lbs 59.5 Kgs	130.7 lbs 59.3 Kgs	131.0 lbs 59.4 Kgs	130.5 lbs 59.2 Kgs
Size - Shipping (LxWxH)	35.8 x 22.0 x 10.7" / 909 x 560 x 272 mm			
Weight - Shipping	142.9 lbs 64.8 Kgs	142.4 lbs 64.6 Kgs	142.6 lbs 64.7 Kgs	142.2 lbs 64.5 Kgs
REGULATORY COMPLIANCE				
Safety and Approvals	FCC Class A, RoHS2 (EU Directive 2011/65/EU & 2015/863/EU)			

Chapter 8: Limited Product Warranty

Para Systems, Inc. (Para Systems) warrants this equipment, when properly applied and operated within specified conditions, against faulty materials or workmanship for a period of three (3) years from the date of purchase. For equipment sites within the United States and Canada, this warranty covers depot repair or replacement of defective equipment at the discretion of Para Systems. Depot repair will be from the nearest authorized service center. The customer pays for shipping the product to Para Systems. Para Systems pays ground freight to ship the product back to the customer. Replacement parts and warranty labor will be borne by Para Systems. For equipment located outside of the United States and Canada, Para Systems only covers faulty parts. Para Systems products that are depot repaired or replaced pursuant to this warranty shall only be warranted for the unexpired portion of the warranty applying to the original product. This warranty applies only to the original purchaser who must have properly registered the product within ten (10) days of purchase.

The warranty shall be void if (a) the equipment is damaged by the customer, is improperly used, is subjected to an adverse operating environment, or is operated outside the limits of its electrical specifications; (b) the equipment is repaired or modified by anyone other than Para Systems or Para Systems approved personnel; or (c) has been used in a manner contrary to the product's User's Manual or other written instructions.

Any technical advice furnished before or after delivery in regard to use or application of Para Systems' equipment is furnished without charge and on the basis that it represents Para Systems' best judgment under the circumstances, but it is used at the recipient's sole risk.

EXCEPT AS PROVIDED HEREIN, PARA SYSTEMS MAKES NO WARRANTIES, EXPRESSED OR IMPLIED, INCLUDING WARRANTIES OF MERCHANTABILITY AND FITNESS FOR A PARTICULAR PURPOSE. Some states do not permit limitation of implied warranties; therefore, the aforesaid limitation(s) may not apply to the purchaser.

EXCEPT AS PROVIDED ABOVE, IN NO EVENT WILL PARA SYSTEMS BE LIABLE FOR DIRECT, INDIRECT, SPECIAL, INCIDENTAL, OR CONSEQUENTIAL DAMAGES ARISING OUT OF THE USE OF THIS PRODUCT, EVEN IF ADVISED OF THE POSSIBILITY OF SUCH DAMAGE. Specifically, Para Systems is not liable for any costs, such as; labor for on-site installation, on-site maintenance or on-site service, lost profits or revenue, loss of equipment, loss of use of equipment, loss of software, loss of data, cost of substitutes, claims by third parties, or otherwise. The sole and exclusive remedy for breach of any warranty, expressed or implied, concerning Para Systems' products and the only obligation of Para Systems hereunder, shall be depot repair or replacement of defective equipment, components, or parts; or, at Para Systems' option, refund of the purchase price or substitution with an equivalent replacement product. This warranty gives you specific legal rights and you may also have other rights which vary from state to state.

No employee, salesman, or agent of Para Systems is authorized to add to or vary the terms of this warranty.

Please go to our web site at www.minutemanups.com/support to fill out the Warranty Registration.



Notes:



Notes: