

DESCRIPTION

Nascom's N505AUTM 2 1/4" TRACK MOUNT FLIP SWITCH™ with universal magnet handles commercial and industrial overhead door applications.

The TRACK MOUNT FLIP SWITCH™ combines the installers' choice of contact configuration with an N35 grade NdFeB magnet for maximum gap performance.

The closed loop versions of the N505AUTM prevents false alarms caused by the up and down movement of overhead doors with our unique **NO DEAD SPOT™** technology. The switch can be mounted with the cable in either direction, without loss of gap.

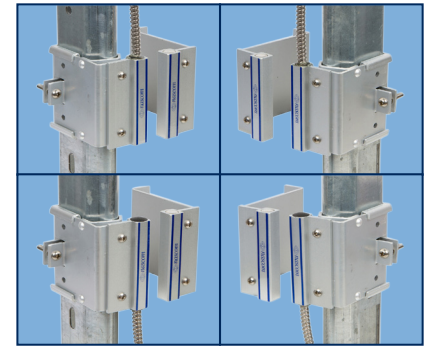

FEATURES

- **NO DEAD SPOT™** TECHNOLOGY
- QUICK SWITCH INSTALL - LESS THAN 60 SECONDS
- UNIVERSAL MOUNT
- 36" 22AWG WIRE LEADS
- EXTRUDED ANNOXIDIZED (TYPE II) ALUMINUM
- FLIP THE SWITCH - GAP IS NOT IMPACTED BY CABLE DIRECTION
- 24" STAINLESS STEEL ARMORED CABLE LEAD PROTECTION
- LISTED TO UL634 STANDARD

ORDERING INFORMATION

PART NUMBER	COLOR	OPERATE GAP (in INCHES)	CONTACT RATING (Max DC/Peak AC Resistive)				STATIC CONTACT RESISTANCE (50mV, 100mA)
			SWITCHING		CARRY		
			V	I	V	I	

CLOSED LOOP, NORMALLY OPEN, 1FA, SWITCH/MAGNET SET:

N505AUTM/ST	SILVER	1.75 to 2.75	200 VDC	0.5 Amps	10vA	1.5 Amps	150 mOhms
-------------	--------	--------------	---------	----------	------	----------	-----------

DUAL CLOSED LOOP, NORMALLY OPEN, 1FA, SWITCH/MAGNET SET:

N505AUTM/ST2CR	SILVER	1.75 to 2.75	200 VDC	0.5 Amps	10vA	0.5 Amps	150 mOhms
----------------	--------	--------------	---------	----------	------	----------	-----------

OPEN LOOP, NORMALLY CLOSED, 1FB, SWITCH/MAGNET SET:

N505AUTM/STFB	SILVER	1.50 to 2.50	30 VDC	0.2 Amps	3vA	0.5 Amps	100 mOhms
---------------	--------	--------------	--------	----------	-----	----------	-----------

SINGLE POLE DOUBLE THROW, SWITCH/MAGNET SET:

N505AUTM/STSD	SILVER	1.50 to 2.50	30 VDC	0.2 Amps	3vA	0.5 Amps	100 mOhms
---------------	--------	--------------	--------	----------	-----	----------	-----------

DOUBLE POLE DOUBLE THROW, SWITCH/MAGNET SET:

N505AUTM/STDD	SILVER	1.50 to 2.50	30 VDC	0.2 Amps	3vA	0.5 Amps	100 mOhms
---------------	--------	--------------	--------	----------	-----	----------	-----------

WIRING SCHEMATIC - IN [mm]

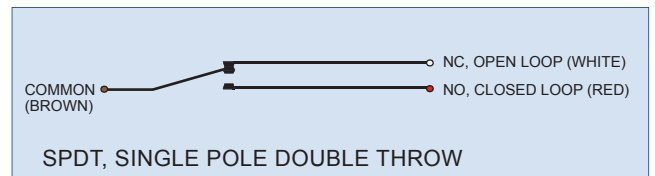
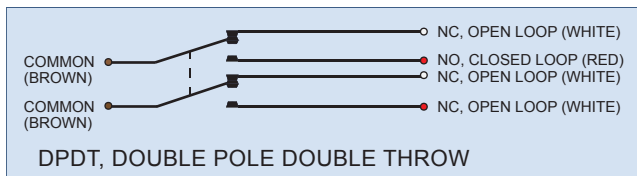
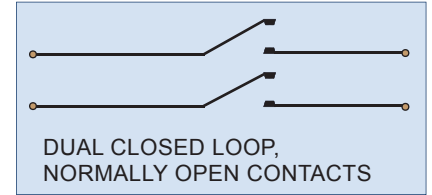
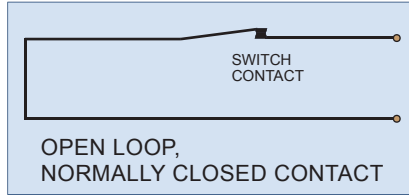
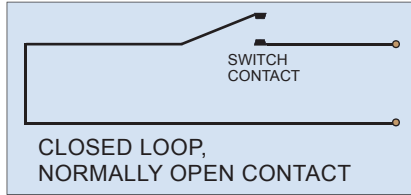

DIMENSIONS - IN [mm]

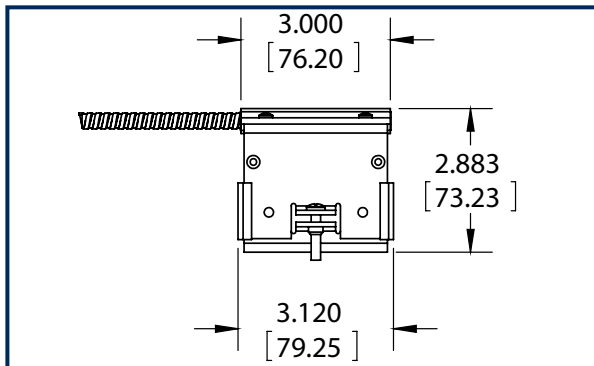

SWITCH

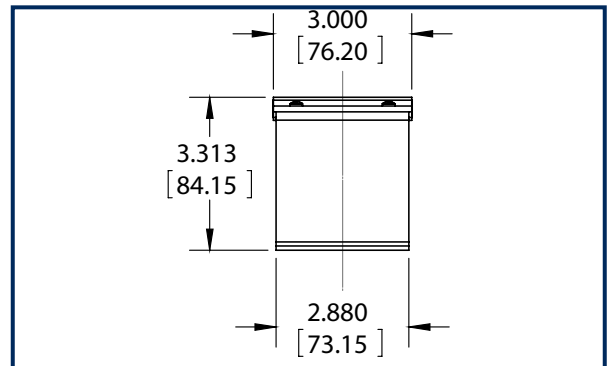

MAGNET

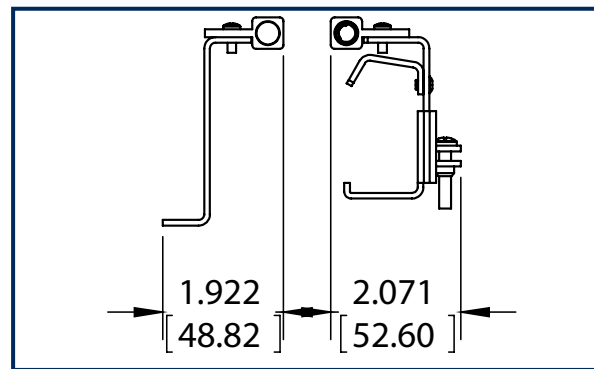

SWITCH/MAGNET SET

INSTALLATION INSTRUCTIONS

The N505AU Universal Track Mount switch and magnet system can be installed on either the right or left side of the overhead door. To change the direction of the direction of the armored cable, remove the 2 screws attaching the switch to the bracket and flip the switch. Insert and re-tighten the screws.

Depending on the type of Roller Guide Track your door has, or operating condition of the door, it may be necessary to remove the rear half of the switch bracket to complete installation.

- Un-pack the switch and magnet assemblies and set aside the magnet bracket assembly.
- Slide the two halves of the switch bracket assembly apart so they are fully extended against the clamping screw.
- Position the switch bracket assembly on the guide roller track in the desired location. Make sure the rear half of the bracket assembly is fully extended around the track.
- Slide the bracket halves together on the track and hold the switch assembly in position. Carefully open and close the door to make sure the door will operate freely without contacting the switch or bracket assembly. (If there is interference between the lower guide roller bracket plate and the switch bracket assembly, use the alternate mounting method below.)
- Secure the switch and bracket assembly to the track by tightening the clamping screw on the side of the bracket.
- With the door closed, align the magnet bracket assembly with the switch. Make sure there is sufficient clearance between the magnet and switch so the door can open and close freely.
- Attach the magnet to the door using #6 self-tapping screws.
- Connect an ohm meter to the switch leads and open and close the door to test switch for correct operation.
- Connect the switch leads to the alarm system.

Alternate Mounting Method: Use the alternate mounting method if your Roller guide track has a web that will not allow the the rear half of the switch bracket to wrap around the back of the roller guid track. Or if there is interference between the switch and bracket assembly and the lower guide roller bracket plate.

- Remove the rear half of the mounting bracket by removing the clamping screw completely and separating the two halves of the bracket set.
- Position the front half of the bracket with the switch on the rail in the desired location. Using the mounting holes in the side of the bracket as your guide, drill through the rail using a 3/16 drill in two locations.
- To mount the bracket, use two pan head machine screws. (**Note:** The screw heads must be on the inside of the rail to allow the door guide roller to pass). From the inside of the rail, insert the screws through the holes in the rail and through the mounting holes in the side of the bracket. Place a washer over the screw and use a nylock type lock nut to secure the bracket to the rail. If nylock type nuts are not available use thread locking compound on the mounting screw threads. This will prevent the mounting screws from loosening due to vibration from the door opening and closing.
- Open and close the door to make sure the door will operate freely without contacting the switch or mounting bracket.
- With the door closed, re-align the magnet actuator with the switch. Make sure there is sufficient clearance between the magnet and switch so the door can open and close freely.
- Connect an ohm meter to the switch leads and open and close the door to test the switch for correct operation.
- Connect the switch leads to the alarm system.

N505AUTM / XX XXX XXXX X XX XXXX XXXX

PRODUCT TYPE (1 or 2 digits):

- ST = SWITCH/MAGNET SET
- SW = SWITCH ONLY
- M = MAGNET ONLY

CIRCUIT (0, 2 or 3 digits):

- Blank = CLOSED LOOP
- 2CR = DUAL CLOSED LOOP
- FB = OPEN LOOP
- SD = SPDT
- DD = DPDT

LEAD LENGTH (zero, 3 or 4 digits):

- Blank - 24 Inches
- All other lengths specified in Inches with 3 digits (e.g. 036 = 36 Inches)
- * lead length is armored cable length- wire length is 12 inches greater than armored cable length

END OF LINE RESISTOR (zero to 4 digits):

- Blank = Resistor in series with the switch
- P = Resistor in parallel with the switch
- SP = Resistor 1 in series to the switch; resistor 2 in parallel to the switch

BUILT-IN END OF LINE RESISTOR VALUE (zero to 4 digits):

- Blank = No built-in end of line resistor
- All other resistor values are specified (e.g. 1K = 1,000 Ω)

LEAD WIRE COLOR (zero to 2 digits):

- Blank = Switch Color except:
 - » resistor contacts standard is red wire
 - » all 2 conductor jacketed wire is grey
- BL = Blue leads
- OL = Orange leads

WIRE TYPE (0 or 1 digit):

- Blank = UL1061 | 22AWG | 7/30
- J = 2-conductor PVC Jacketed NEC Type CL2 and CM