

Vi3002WP

Hardened Weatherproof Ethernet and 60W PoE Repeater

Features

- Extends Ethernet and 60W PoE range up to 656 ft. (200m)
- PoE powered with no need for local power
- Conforms to IP67 standards for total moisture and dust protection
- IEC60068-252 certified for operation in salt laden environments
- Operates at wide temperature range -40°C to +75°C
- No network configuration required
- Full network bandwidth 10/100Mbps for transmitting the highest megapixel cameras
- Pass-Through-PoE up to 60W for high power PTZ cameras
- Extremely compact size enables easy installation
- Multiple Vi3002WPs can be used to extend IP video and PoE at distances up to 3000ft.



Vigatron's MaxiiNet™ Vi3002WP is an Ethernet and 60W PoE repeater that provides a cost effective method for extending distances beyond the Ethernet limit of 328 feet (100m) for IT or CCTV installations. Each unit can extend Ethernet and PoE for 328 feet (100m). Up to 8 units can be combined to achieve a distance up to 3,000 feet (909m) for IP video and PoE transmission. The Vi3002WP is a high performance device that meets the demands for the highest PoE powered PTZ domes and LED lighting eliminating the need for local power.

The Vi3002WP conforms to IP67 and is designed for the hardest environmental conditions with total dust protection, water immersion, and an operating temperature range of -40°C to +75°C. It uses PoE only and its patent pending Pass-Through-PoE (PTPTM) eliminates the need for local power supplies. Complies with 60W UPoE.

It is compact in size and easy to install. The Vi3002WP is very cost effective and is a perfect solution for any extended IP transmission applications.

Technical Specification*

Electrical

Data Rate	10/100BaseTX (10/100Mbps) Auto-configuring
Power Transmission Standard	802.3af (15.4W), 802.3at (30W), 74W compliant to UPoE
Network Connection	2 x RJ45 weatherproof IEC 60603-7
Wiring Support	1 or 4 pair Cat 5/5e/6
Power Consumption	1W (PoE only)
Extended Distance Supported	328 ft. (100m) per link
Data Interfaces and Compliances	RFC 768 UDP, RFC 2068 HTTP RFC 793 TCP, RFC 791 IP RFC 1783 TFTP, RFC 894 IP over Ethernet RFC 2544 TCP/IP Packet Transmission
PoE Compatibility	IEEE 802.3af, IEEE 802.3at, 60W PoE

Regulatory

Safety	CE, FCC
Environmental	RoHS, WEEE

Environmental

Humidity	Total Moisture Protection Compliant to IP67
Temperature	Operating: -40°C to +75°C per NEMA-TS2 Testing** Storage: -40°C to +85°C
Dust	Total Dust Protection Compliant to IP67
Environment	IEC 60068-252 Salt Laden

Mechanical

Dimensions	3.26 x 1.57 x 1.83 in., 3.26 x 3.99 x 4.65 cm (HxWxL)
Weight	0.50 lb, 227 g
Material	ABS

*Specifications subject to change without notice.

Ordering Information

Part No.	Description
Vi3002WP	IP67 Ethernet and 60W PoE Repeater

Related Products

Part No.	Description
Vi3002	Ethernet and 60W PoE Repeater
Vi30002U	Ethernet and 90W PoE Repeater



Mechanical Drawings

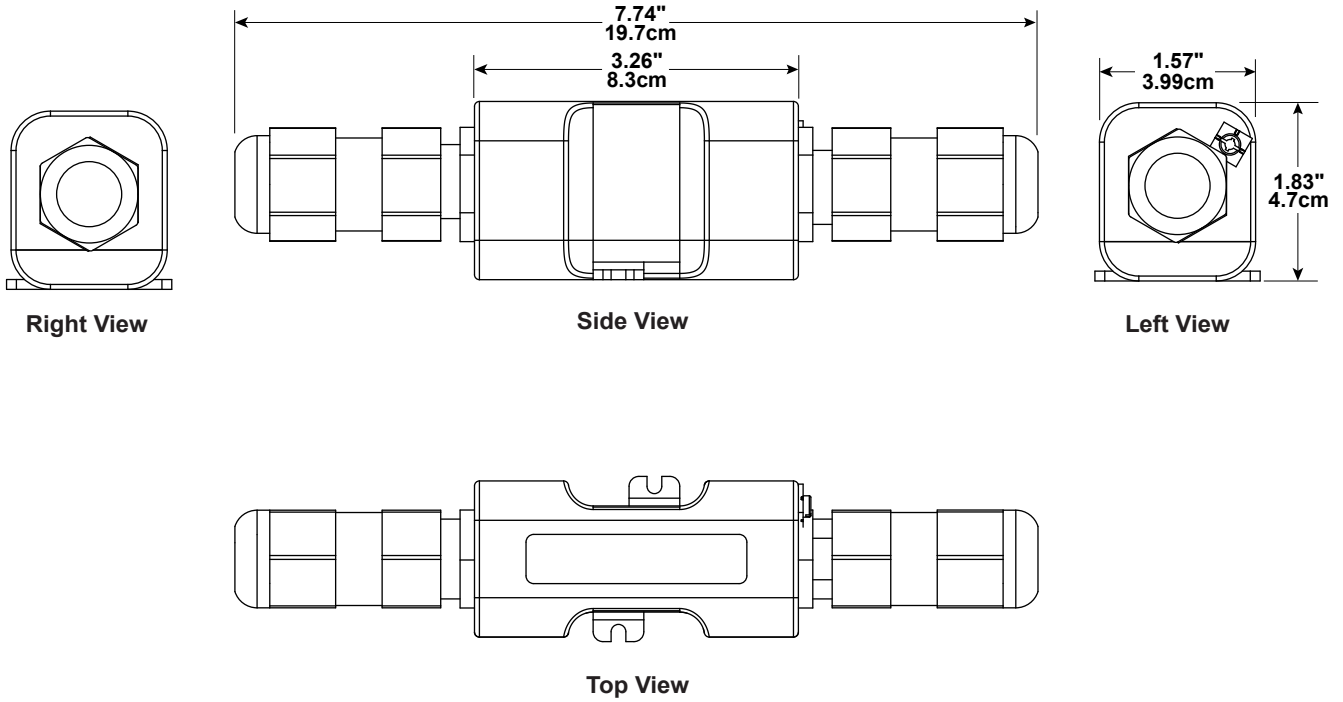

Application Diagrams

Cat 5/6

Extending Ethernet and 60W PoE from a PoE Switch

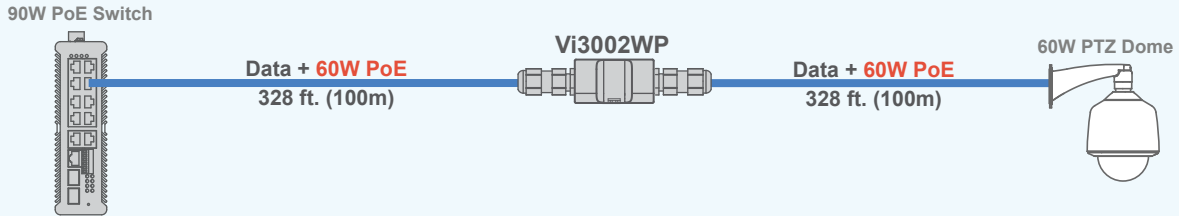

A single Vi3002 extends Ethernet and PoE from a PoE switch for total Distance of 656 ft. (200m).

Extending Ethernet and 60W PoE from a Switch & PoE Midspan

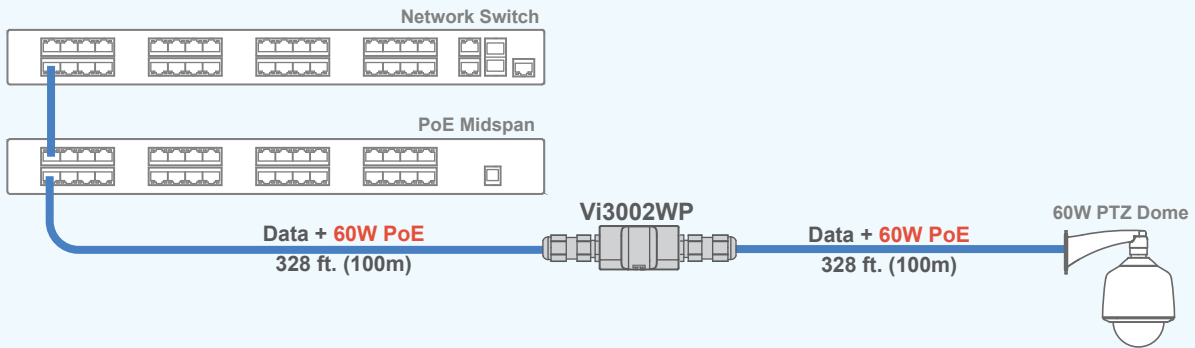

A single Vi3002 extends Ethernet and PoE from a network switch and a PoE Midspan for total Distance of 656 ft. (200m).

Extending Ethernet and 60W PoE using multiple Vi3002WPs

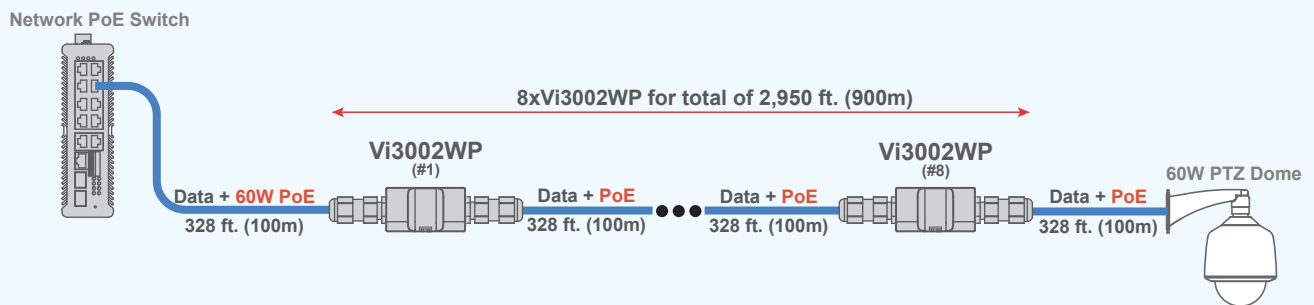

Up to 8 x Vi3002 can be used in series to extend Ethernet and PoE for up to 2950 ft. (900m).

Application Diagrams

— Cat 5/6

Connecting Multiple PoE Cameras at Extended Distances

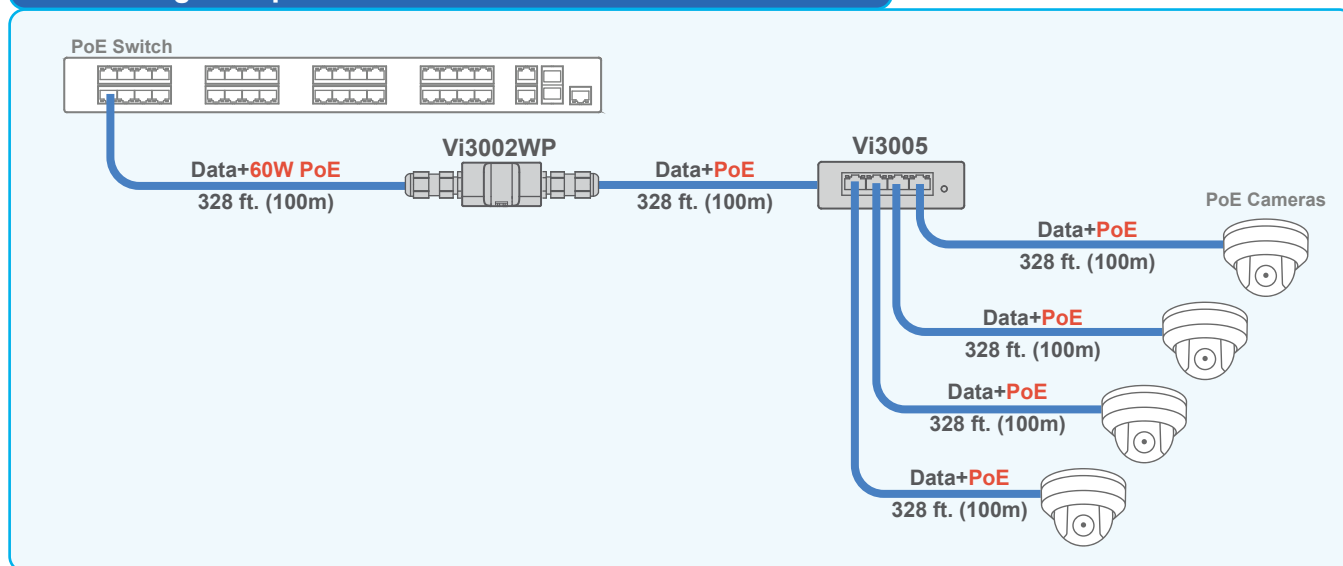

The Vi3002 can be used to connect multiple PoE cameras at extended distances.