

EZ-SnapJack™ Instructions

©2016 Platinum Tools Inc. All rights reserved. 01/16

PLATINUM TOOLS

- 1) Remove 2" of the outer cable jacket using P/N 15015, Cat5e/6 Cable Jacket Stripper.

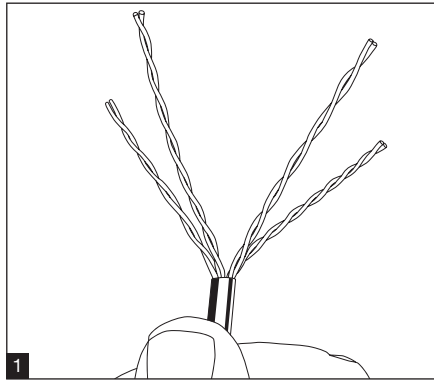

- 2) Separate pairs and follow the color code on the wire guide bar, per the A or B.

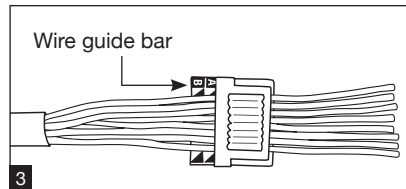
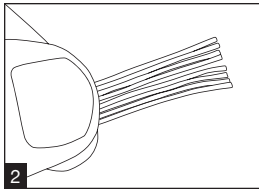

- 3) Insert the conductors through the holes of the wire guide bar.

IMPORTANT: The color code on the wire guide bar is correct! Follow it, it will work!

- 4) Slide the wire guide all the way down to the outer cable jacket so that it fits up against the twisted pairs of the cable.

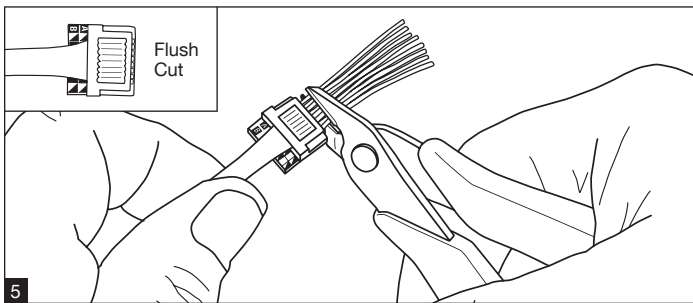
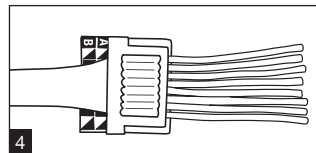

- 5) Cut off the extra wire extending from the guide so that it is flush with the wire guide edge using the Flush Cutter, P/N 10531.

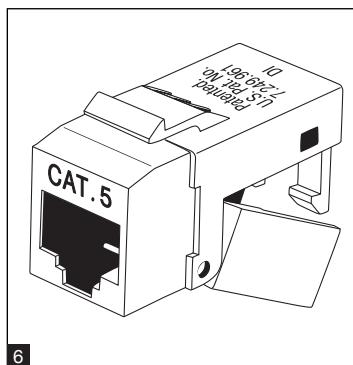

- 6) Open the EZ-SnapJack so that the hinged portion is on the bottom at 6 o'clock. Then rotate to 3 o'clock.

- 7) Insert the prepped wire guide into the hinged portion, pushing it forward until it stops. Hold it in this position.

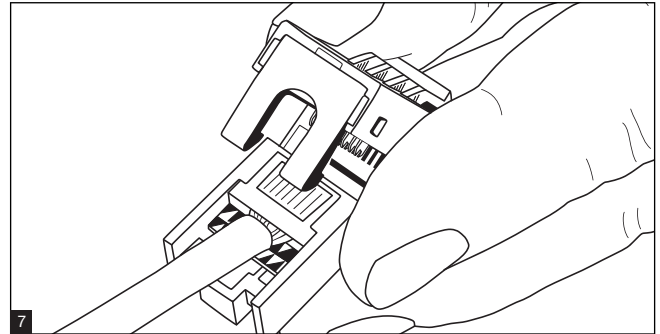

- 8) Close the hinged portion until it 'snaps' and latches into place.

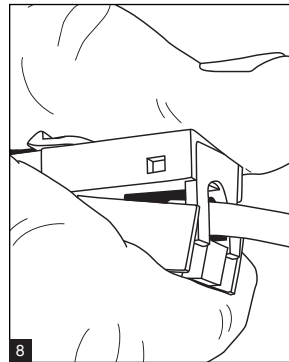

- 9) Insert the terminated EZ-SnapJack into the backside of the wall plate.

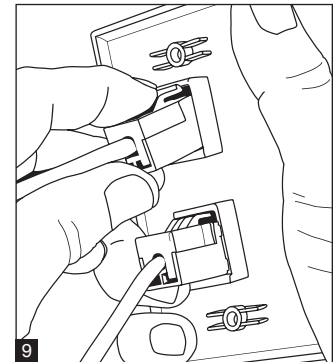

- 10) To Re-Open SnapJack: Using a small slotted screwdriver, lightly pry open the two EZ-Snap-Jack clasps (Fig 10).

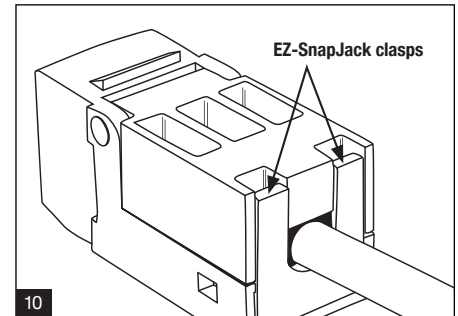

CAT6 Cable Reducer Piece (For Cat6 version only)

Re-size the cable opening to support smaller Cat6 diameter cable as well as Cat5e.

Cable Reducer Installation: Insert the reducer piece into the U shaped cable slot and push it all the way until fully seated and in place.

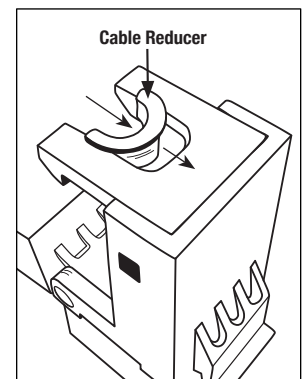

Test Equipment Depot
1-800-517-8431

99 Washington Street
Melrose, MA 02176
Phone 781-665-1400
Toll Free 1-800-517-8431