

VINGTOR STENTOFON

Turbine Compact IP Mounting Manual

1 Turbine Compact IP Stations

This document describes the dimensions, mounting procedure, and connections of the Turbine Compact IP Stations. **Zenitel takes no responsibility for damages caused by improper or inadequate mounting.** The Turbine Compact IP product range comprises the following stations & accessories:

Item Number	Type	Item Name
1008111020	TCIS-2	Turbine Compact IP - stainless steel front plate
1008111030	TCIS-3	Turbine Compact IP - thermoplastic front plate



1.1 TCIS Compact Station Dimensions

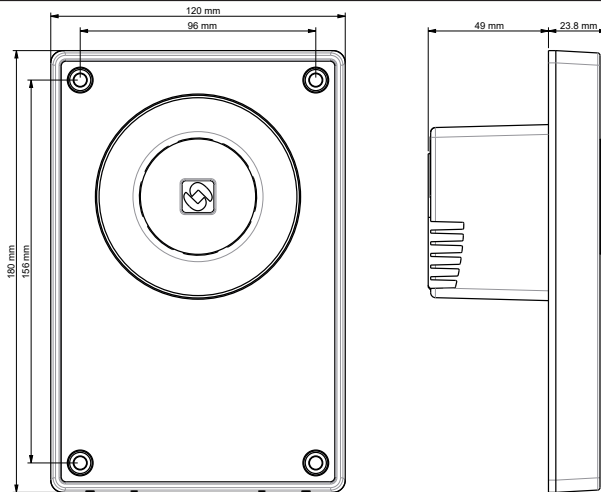

* The latest product information / specification can be found at hanwhasecurity.com
 * Design and specifications are subject to change without notice.
 * Wisenet is the proprietary brand of Hanwha Techwin, formerly known as Samsung Techwin.

2 On-Wall Surface Mounting

2.1 On-Wall Surface Mount Back Box - TA-1

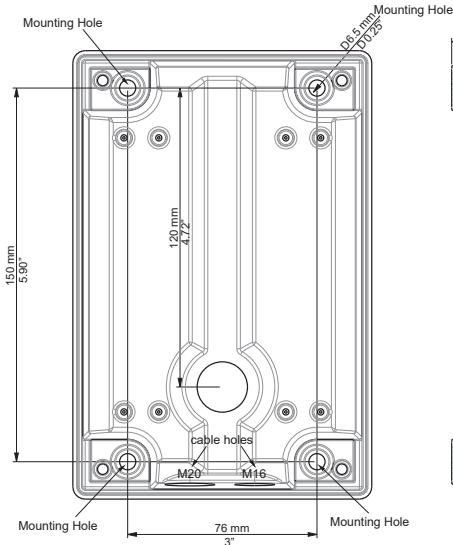

① **IP-66 rating is only valid when TA-1 Back Box is used**

Mounting holes are to be drilled as shown.

Max. recommended screw diameter: ISO M6 or ANSI 1/4".
Screw length must be greater than 25 mm or 1".

A4 stainless steel socket head screws/bolts are recommended.
Max. recommended screw head diameter: 9.5 mm or 3/8".

Included:

4x M5 Fasteners
2x Grommets
1x M20 Cable Gland
4x Washers for extra protection against corrosive effects between surfaces to be placed at bottom of the 4 mounting holes.

2.2 On-Wall Surface Mounting Procedure

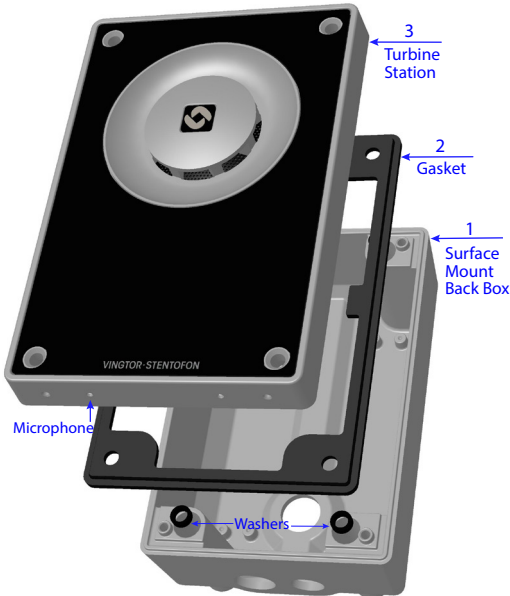

- ① **The Gasket MUST be mounted to seal the station!**
- ① **Ensure the station is mounted vertically with the microphone aperture facing down.**
- ① **Ensure there is enough clearance under the station so that the microphone aperture is NOT smothered.**
- ① **Place the washers at the bottom of the 4 mounting holes on the back box.**
- ① **Use the grommets and M20 cable gland provided for the cable holes on the back box.**

1. Mount the back box onto the wall using A4 socket head screws
2. Fit the gasket onto the back box with the ridged side facing down
 - Plug the Ethernet cable into the RJ-45 port on the station
3. Mount the Turbine station onto the back box with the M5 fasteners provided applying 1.5 Nm torque

3 Flush Mounting

3.1 Flush Mount 2-Gang Double-Depth Back Box - TA-2

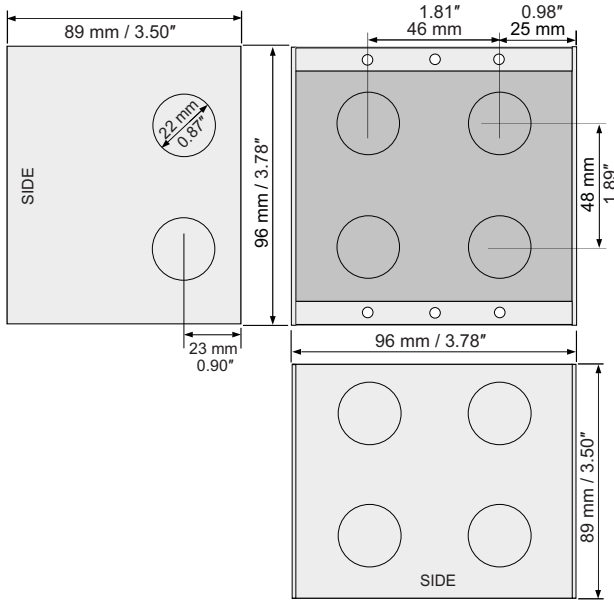

① It is recommended to utilize back boxes with weep holes at the bottom.

3.2 Flush Mount Bracket - TA-5

① **The TA-5 Bracket is mandatory for flush mounting.**

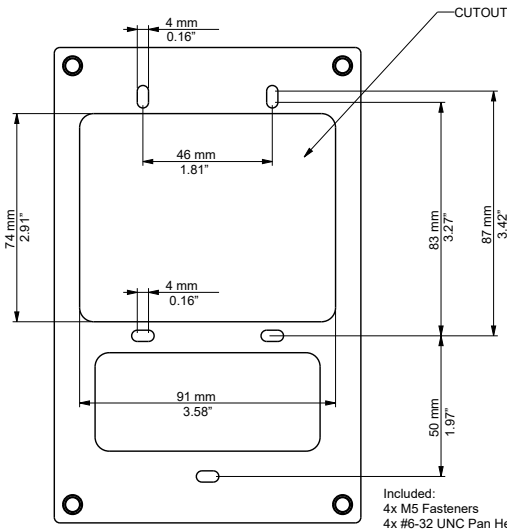

Fits US 2-GANG electrical boxes

Recommended screw diameter: up to M4 (5/32")

Use #6-32 UNC pan head screws for the TA-2 back box

3.3 Flush Mounting Procedure

① **The Gasket MUST be mounted to seal the station!**

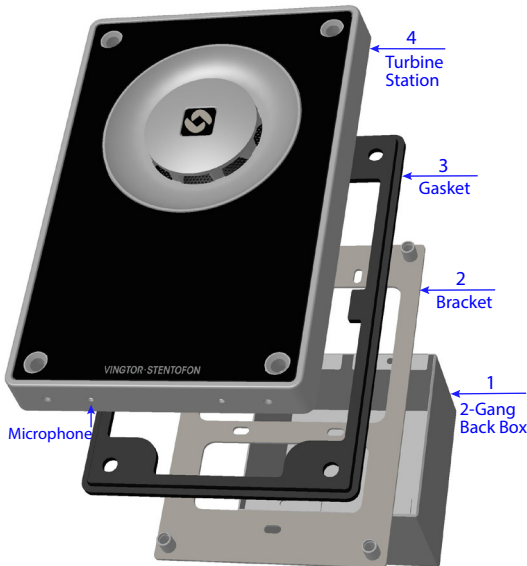

- ① **Ensure the station is mounted vertically with the microphone aperture facing down.**
- ① **Ensure there is enough clearance under the station so that the microphone aperture is NOT smothered.**
- ① **Apply silicone sealant all around the aluminum frame of the station, making sure to leave the microphone aperture open.**

1. Mount the 2-gang back box into the wall
2. Mount the bracket onto the back box with #6-32 UNC pan head screws
3. Fit the gasket onto the bracket with the ridged side facing down
 - Plug the Ethernet cable into the RJ-45 port on the station
4. Mount the Turbine station onto the bracket with the M5 fasteners provided

4 Connections

The Turbine Compact IP station has a RJ-45 PoE/LAN port, and 6-pin & 10-pin external connectors.

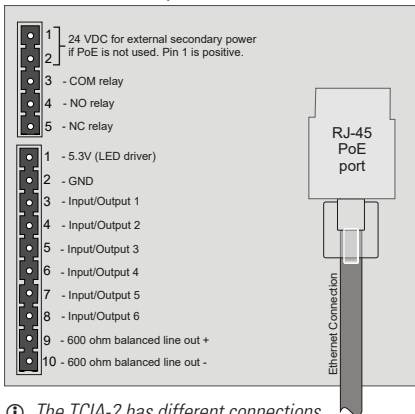

Ethernet / Power	10/100 Mbps Ethernet RJ-45 port for LAN (uplink) connection. Supports PoE (802.3af). Draws power from either spare line or signal line.
Secondary Power	24 VDC (16 – 48 V) secondary power is provided from an external adapter.
Relays	There is one Double Throw relay contact with 60W switching power. COM, NO, NC contacts are provided. Max: 250VAC/220VDC, 2A, 60W.
Input/Output	6 I/Os are available. Each I/O can be configured as either input, output, or LED driver.
Audio Line Out	A balanced 600 ohm audio line out with induction loop signal

① *The TCIA-2 has different connections*

① *Use cables crimped with ferrules for terminal block connectors*



- When the Turbine Station is connected to the network, its IP address is automatically obtained from a DHCP server or an IP address in the range 169.254.x.x will be assigned.
- To make the station speak its IP address, press the call button on the station.

