

REVISIONS

ZONE	REV	DESCRIPTION	DATE	APPROVED
	A	A-SEP-08 SMKL-2	SEPT.'08	

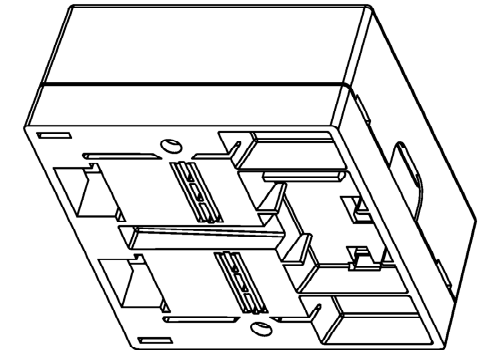
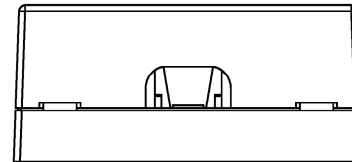
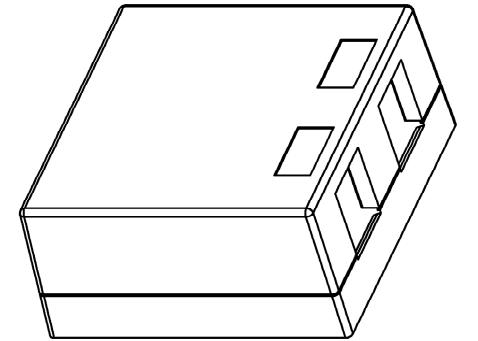
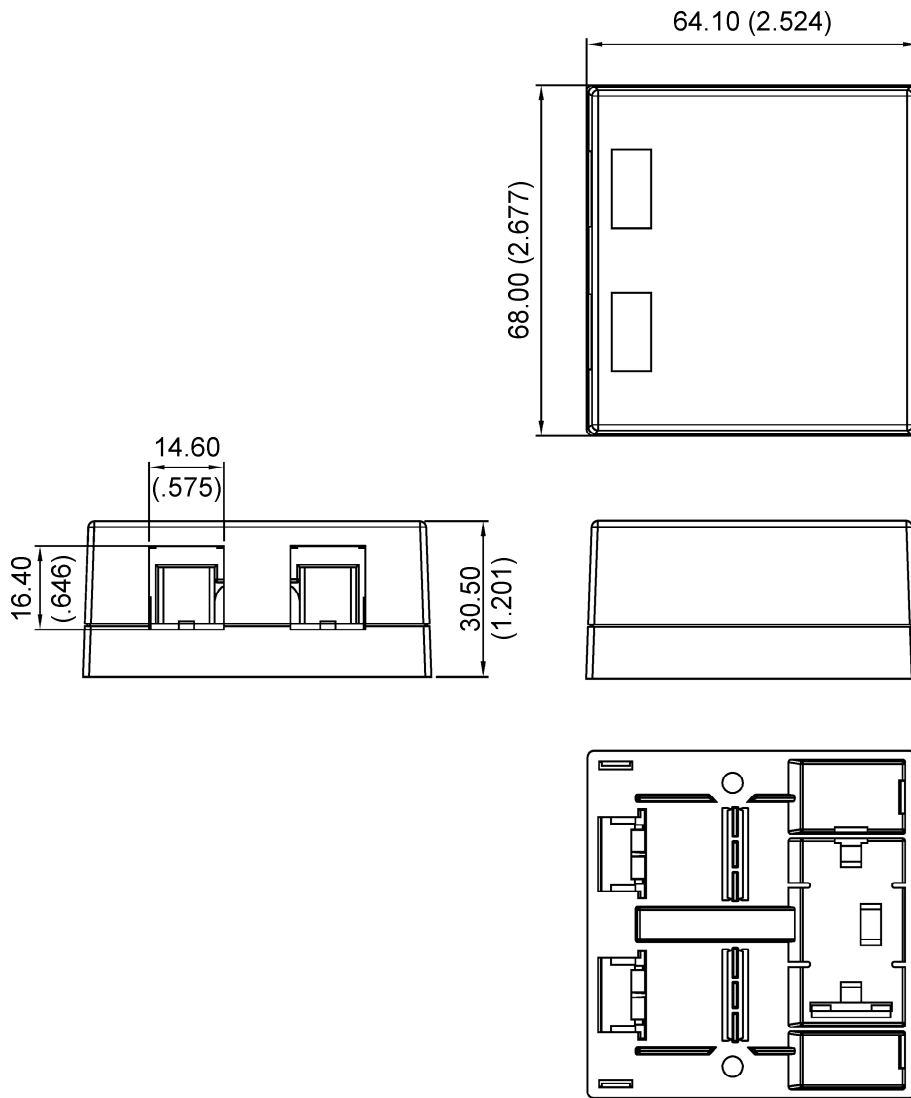

NOTES:
1. MATERIAL: ABS UL 94V-0

UNLESS OTHERWISE SPECIFIED DIMENSIONS ARE IN MILLIMETERS (INCHES) TOLERANCES:		MATERIAL:	AS NOTES		
MM	IN	ANGULAR			
.X ± .2	.X ± .016	X ± 1°			16295 NW 13th Ave, Ste A, Miami, FL 33169, PH: (305) 944-7710, FX: (305) 949-4483, www.signamax.com
.XX ± .1	.XX ± .008	X ± .5°			
	.XXX ± .004				
PROJECT ID SPCS - PD		FILE SPCS - PD.KSM-MMB.SMKL2	SEPT'08		
PROCESS	INITIALS	NAME	DATE	TITLE	
DRAWN				SMKL-2 (2-PORT SURFACE MOUNT BOX)	
CHECK				SIZE	CAGE CODE
APPROVED				A	DWG. NO.
					REV
					A
SCALE 1:1.5		UNIT MM (IN)	SHEET 1 OF 1		