



**Safety Technology  
International**

**Illuminated Stopper® Station  
Push Button**  
Model SS2xx6



**Rely on STI®**

## Dimensions

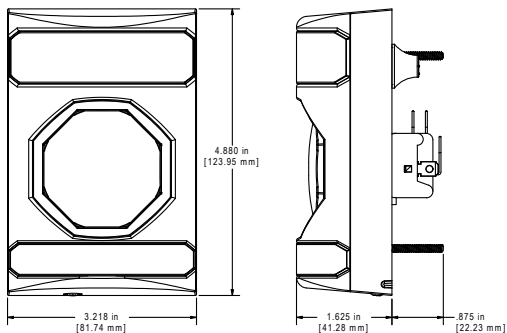

## Switch Rating

2 momentary independent Form "C" contacts, DPDT

Rated at: 10A, 125/250VAC; ½ HP

6A, 30 VDC

100,000 operations

Temperature: 32°F to 120°F (0°C to 49°C)

## NOTE

LED connection is polarity sensitive. If LED does not light, switch positive and negative wiring or remove LED and rotate 180°. 24 volt is included and will operate on 12 volts; however not as bright. 12 volt LED's are also available.

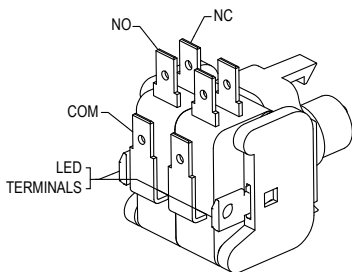

## **Safety Notice to Installers and Users**

This push button has been tested according to UL2017. It is important to read, understand and follow all instructions provided with this product. Non-fire alarm initiating devices are listed in UL category UEHX. It is the installer's responsibility to comply with NEC and Canadian electrical code, mounting specifications according to ADA and other applicable fire and electrical codes. To avoid electrical shock, DO NOT attempt to install this product when power is on. To avoid possible confusion with fire alarm initiating devices, do not mount a red stopper station near a manual fire alarm initiating device. ADA mounting compliance requires the operable part of the initiating device shall not be less than 1.1m (3 1/2 ft.) or greater than 1.37m (4 1/2 ft.) above finished floor service. After installation and testing are complete, provide a copy of this manual to all personnel responsible for testing and maintenance of this product. Push buttons for outdoor use must be mounted with STI outdoor rated covers.

Remarques sur l'installation: Ce bouton-poussoir a été testé selon UL2017. Il est important de lire, de comprendre et de suivre toutes les instructions fournies avec ce produit. Les dispositifs de déclenchement d'alertes non incendie sont répertoriés sous la catégorie UL UEHX. Il incombe à l'installateur de se conformer aux normes NEC et Code canadien de l'électricité, aux spécifications de montage selon l'ADA et aux autres codes de prévention des incendies et de l'électricité en vigueur. Pour éviter un choc électrique, NE tentez PAS d'installer ce produit lorsqu'il est sous tension. Pour éviter toute confusion possible avec les dispositifs de déclenchement d'alertes d'incendie, n'installez pas un avertisseur Stopper rouge à proximité d'un dispositif de déclenchement d'alarme d'incendie manuel. La conformité aux règles d'installation de l'ADA exige que la partie utilisable du dispositif de déclenchement soit installée à une hauteur située entre 1,1 m (3 1/2 pi) et 1,37 m (4 1/2 pi) au-dessus du plancher fini. Une fois l'installation et les essais terminés, vous devez fournir une copie de ce manuel à l'ensemble du personnel chargé de l'essai et de l'entretien de ce produit. Les boutons poussoirs pour utilisation à l'extérieur doivent être installés avec couvercles pour l'extérieur de STI.

## Install or Remove Contact Block

### INSTALL

To attach, align tabs (as shown) and gently snap top then bottom. Be sure to hear BOTH tabs snap into place. (Can be reversed if wiring comes from the bottom of the box.)

### REMOVE

Repeat STEP A for the top and bottom tab before pulling on contact block.

**Step A:** Position small flat screwdriver blade under tab and gently rotate until tab disengages. The contact block will rotate a little. **DO NOT PULL YET.**

**Step B:** Repeat for opposite tab.

**Step C:** When both tabs are disengaged, pull the contact block straight off.

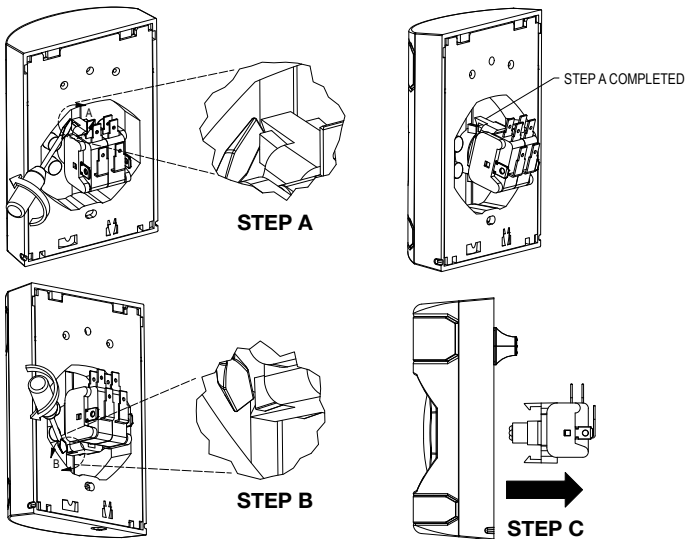

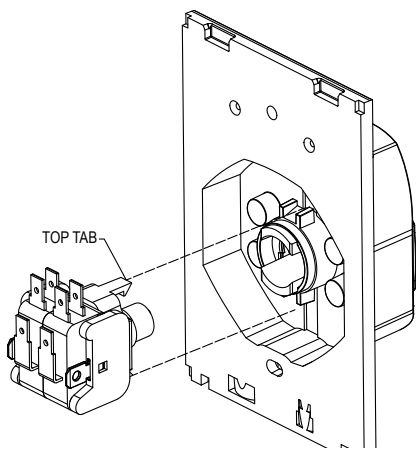

## Mounting

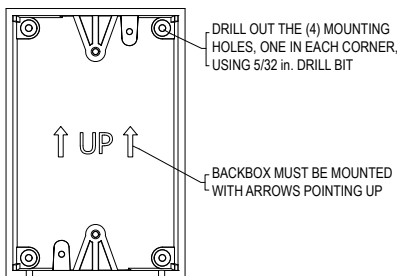
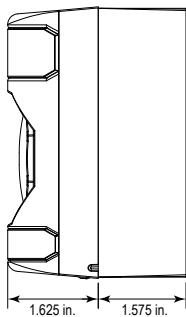

# Surface Mounting

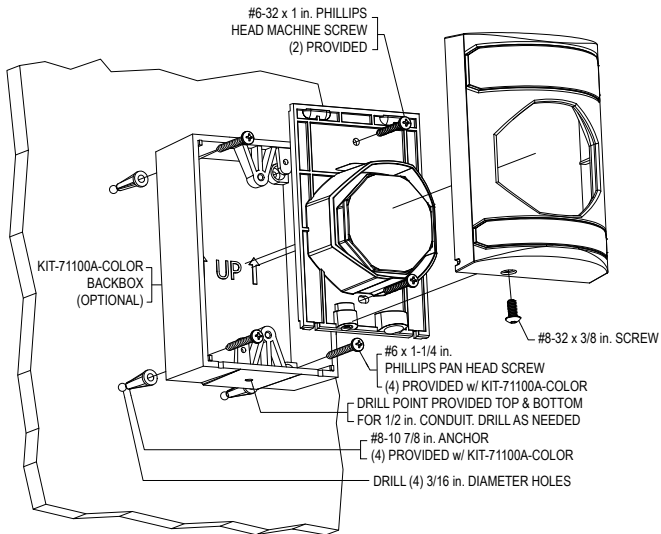

## Testing Approvals

It has been tested and approved or listed by:

· Underwriter Laboratories and cUL No. S7255.

## Warranty

Three year guarantee against breakage of polycarbonate in normal use (one year on electro mechanical and electronic components).

Electronic warranty form at [www.sti-usa.com/wc14](http://www.sti-usa.com/wc14).

**⚠** WARNING: This product can expose you to chemicals including Dichloromethane, which is known to the State of California to cause cancer, and Bisphenol A (BPA), which is known to the State of California to cause birth defects or other reproductive harm. For more information go to [www.P65Warnings.ca.gov](http://www.P65Warnings.ca.gov).



USA



**Safety Technology  
International**



EMEA

2306 Airport Rd • Waterford, MI 48327, USA

Phone: 248-673-9898 • [info@sti-usa.com](mailto:info@sti-usa.com) • [www.sti-usa.com](http://www.sti-usa.com)

Taylor House • 34 Sherwood Road • Bromsgrove, Worcestershire • B60 3DR • England

Tel: +44 (0)1527 520 999 • [info@sti-emea.com](mailto:info@sti-emea.com) • [www.sti-emea.com](http://www.sti-emea.com)

Unit 7A • Lockhead Avenue • Airport Business Park • Waterford • X91 HWF2 • Ireland

[info@sti-emea.com](mailto:info@sti-emea.com) • [www.sti-emea.com](http://www.sti-emea.com)