



Safety Technology International

STI-1229-HAZ

Enclosure Only

STI-1229HTR-HAZ

Enclosure with 110 VAC Heater Option

STI-1229HTR240-HAZ

Enclosure with 240 VAC Heater Option



Features

- Hazardous Classification Class II Groups F&G Div. 2 and Class III locations.
- Maintains operating strobe appliance temperature with external temperatures to -70°F (-57°C).
- Enclosure tested to NEMA 4X Standards. Equivalent to an IP 66 rating.
- UL/cUL Listed.
- CSFM requires local approval only.
- Protects ADA compliant strobes to UL 1971 Standards.

Operation

For use in areas where temperature or environmental conditions exceed the operating range of fire strobe signaling devices. Unit requires 24 VDC continuous for fan operation and 110 VAC or 240 VAC for heater, as well as power for strobe operation and supervision for temperature indicator. Fan runs continuously to maintain uniform temperature. Heater cycles as required to maintain operating temperature range for listed strobes.

We protect the things that protect you.®

Warnings

The enclosure is used to protect UL/cUL listed 1638 and 1971 visual notification appliances at temperatures down to -70°F (-57°C). It is the installer's responsibility to comply with NEC 70 Articles 502 and 503, NFPA72, and other applicable fire and electrical codes. Conduit or raceway paths need to be sealed as near to the enclosure as possible. Installer should have maintained supervision over the low temperature thermostat. The low temperature monitoring thermostat makes the circuit at +32°F (0°C) and clears the circuit at +50°F (+10°C). This listing requires that the fire alarm supervisory control module be only of the latching type. On the appliance mounting plate is a label where you should record the installation date. Also include below the serial number and installation date on the instruction sheet for quick reference.

Serial Number _____ Installation Date _____

Installation Notes

1. The enclosure is rated to protect signaling appliances indoors and outdoors and in areas of direct weather exposure.
2. When covering fire-signaling appliances with the enclosure, some light loss occurs. Please follow the guidelines listed during installation.
3. Strobe light loss values for respective manufacturers are shown on page 3. To determine the new composite candela value of the use with the guard refer to the sample calculation shown on page 3 for a manufacturer's strobe.
4. Record the manufacturer's candela value as "A" and the light loss value as "B" and the assembly value as "C". Example: A 60 candela strobe with a 30% light loss transmission value. Value "A" is now 60. Value "B" is (60 times 30% or 0.30) in this case 18.
5. Now value "C" is value "A" minus value "B" or $60 - 18 = 42$ candela light source. Now refer to NFPA tables for proper room size that newly established value "C" will work in. Then submittal installation drawings must show the composite candela value in this example 42.
6. On a multiple candela value strobe such as 15/30/75 a calculation must be done for each value and the drawing notation composite value for each number on the strobe.
7. All field wiring within this enclosure must be rated for a minimum operating range of 0°C - 110°C.

Performance Review

Manufacturer	Category/Model	Light Loss
American Security Equip. Co.	Select-a-strobe SL24W-153075	36% Light Loss
Faraday	2700	33% Light Loss
Gentex	GES24*	36% Light Loss
System Sensor	SS24110ADA	35% Light Loss

*NOTE: GES24 may be followed by W, R or P.

Polycarbonate Cleaning Instructions

Rinse with water to remove abrasive dust and dirt. Wash with soap or mild detergent, using a soft cloth. Rinse once more, then dry with a soft cloth or chamois. Exercise caution when using water inside enclosure. Make sure unit is completely dry inside before reassembling. Do not use razor blades.

Specifications

Polycarbonate Enclosure

Flammability	UL94 V-2
Wall Thickness	0.2 in. (5.1mm)
NEMA Rating	4X, indoor and outdoor use
Hazardous Rating	Class II Groups F&G Div. 2 and Class III locations
Warranty	Three year guarantee against breakage of polycarbonate in normal use (one year on electro mechanical and electronic components).

Silicone Laminate Heater

STI-1229HTR-HAZ 110 VAC 50/60 Hz	UL Recognized Component
STI-1229HTR240-HAZ 240 VAC 50/60 Hz	UL Recognized Component
100 Watts	
Life: @-10°C (14°F) ~ 70°C (158°F)	5 Years
Duty Cycle: -40°F (-40°C)	53%
-70°F (-57°C)	71%

Fan

24 VDC, 90 mA	UL Recognized Component
Life	5 Years Continuous Duty
WARNING: The polarity of the circulating fan is important as it only rotates in one direction with red lead being positive.	

Gasket

Material	Neoprene
Life	5 Years

Installation Instructions

Mount Enclosure back box - Refer to Fig. 1

1. Remove appliance heater assembly from back box and set aside.
2. Mount back box in desired location (wall mount only) using the four #10 x 1-1/2" screws and anchors (provided). Drill a 1/4" diameter pilot hole for plastic anchors at spacing in Fig. 1.

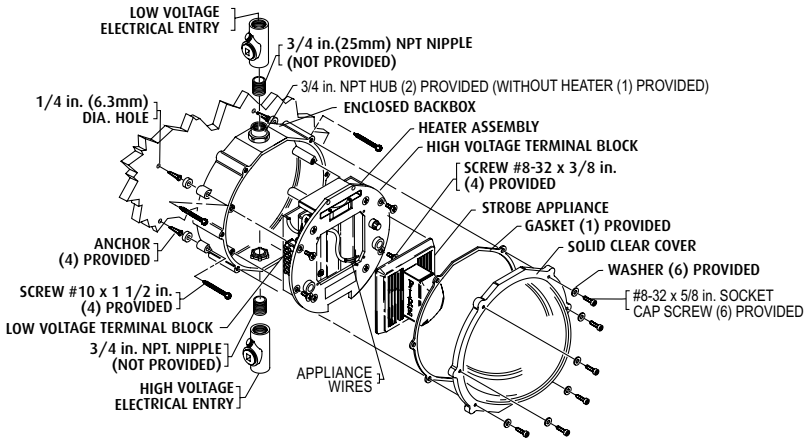

FIGURE 1

3. Attach conduit hub to a 3/4" NPT nipple and conduit seal fitting to the back box, top and bottom. **Note:** A conduit seal fitting must be used on both top and bottom conduit entries as close to the unit as possible. Use conduit seal Crouse-Hinds 3/4" EYSX 21 or equivalent. Conduit should be installed according to applicable NEC and local codes.
4. Pull wiring into back box. **Note:** High Voltage (110 or 240 VAC) wiring must enter thru bottom conduit and low voltage and signaling wires must enter thru top conduit and remain separated per NFPA 70, NEC, and local codes.

High Voltage Wiring - Refer to Fig. 2

5. **Connect high voltage:** Make sure 110 or 240 VAC power is "OFF". Refer to high voltage schematic diagram on page 6.

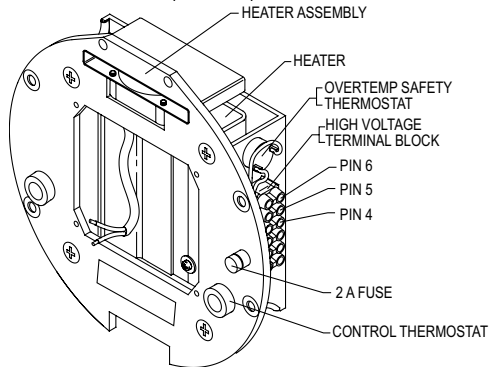
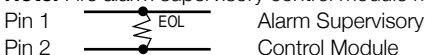

FIGURE 2

Low Voltage Wiring - Refer to Fig. 3 & Schematic drawings on page 6

6. **Connect Supervisory Module:** MConnect EOL device (not included) between pins 1 and 2 of low voltage terminal block. Pins 1 and 2 should then be connected to the fire alarm supervisory control module.

Note: Fire alarm supervisory control module must be of the latching type only.



7. **Connect Fan Power**

Note: Fan will not operate if polarity is reversed. Refer to low voltage schematic on page 6.

Pin 3 -24 VDC

Pin 4 +24 VDC

8. **Connect Strobe Appliance Power from Fire Alarm Panel**

Pin 5 -16-33 VDC

Pin 6 +16-33 VDC

9. Connect strobe out to next device (if needed)

Pin 7 - 16-33 VDC

Pin 8 +16-33 VDC

10. Attach heater assembly to back box using (4) #8-32 x 3/8" flat head screws into heater assembly mounting bosses on back box (see Fig. 1). Make sure all service wiring is gathered away from the heater and be careful not to pinch wire under heater assembly. Fan must be mounted toward top of enclosure.

11. Wire strobe in and out using Teflon coated wire provided. (White-Positive/Black-Negative) and attach to the strobe mounting bosses on heater assembly.

12. Record installation date on label and in manual (page 2).

13. Install cover and gasket with (6) #8-32 x 5/8" socket cap screws and (6) flat washers as shown in Fig. 4. Max. torque 18-20 in./lb.

14. Turn all power to "ON" position.

Note: Fan runs continuously. This system requires three sources of power:

1. 110 or 240 VAC heater on the load side of the fuse holder.
2. 24 VDC power source for the circulating fan. Check fan to see if operating; if not check polarity and reverse then try again.
3. 16-33 VDC fire alarm notification circuit for strobes and temperature warning monitor.

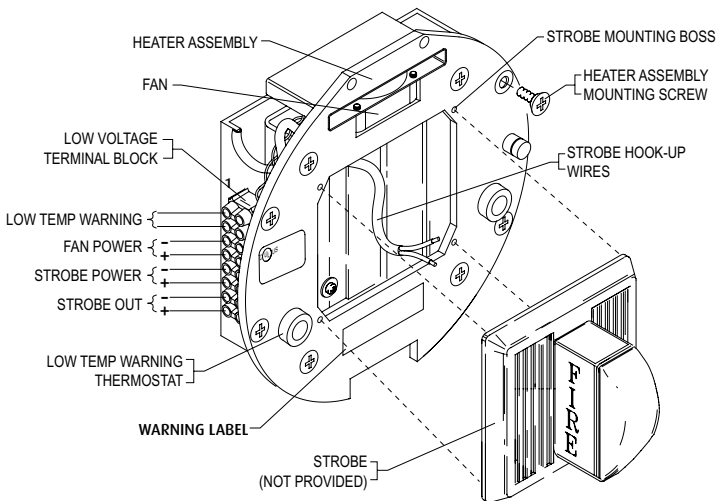
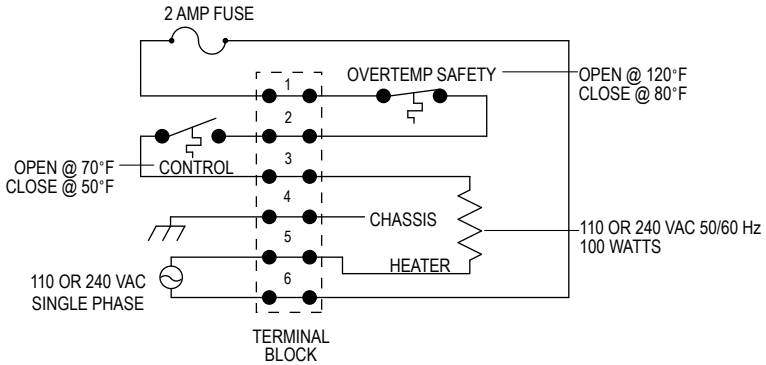

FIGURE 3

Schematic Diagrams

HIGH VOLTAGE CIRCUIT



LOW VOLTAGE CIRCUIT

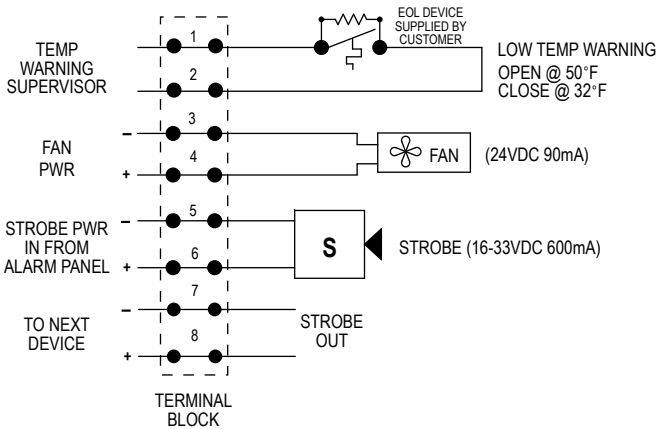

Product Assembly

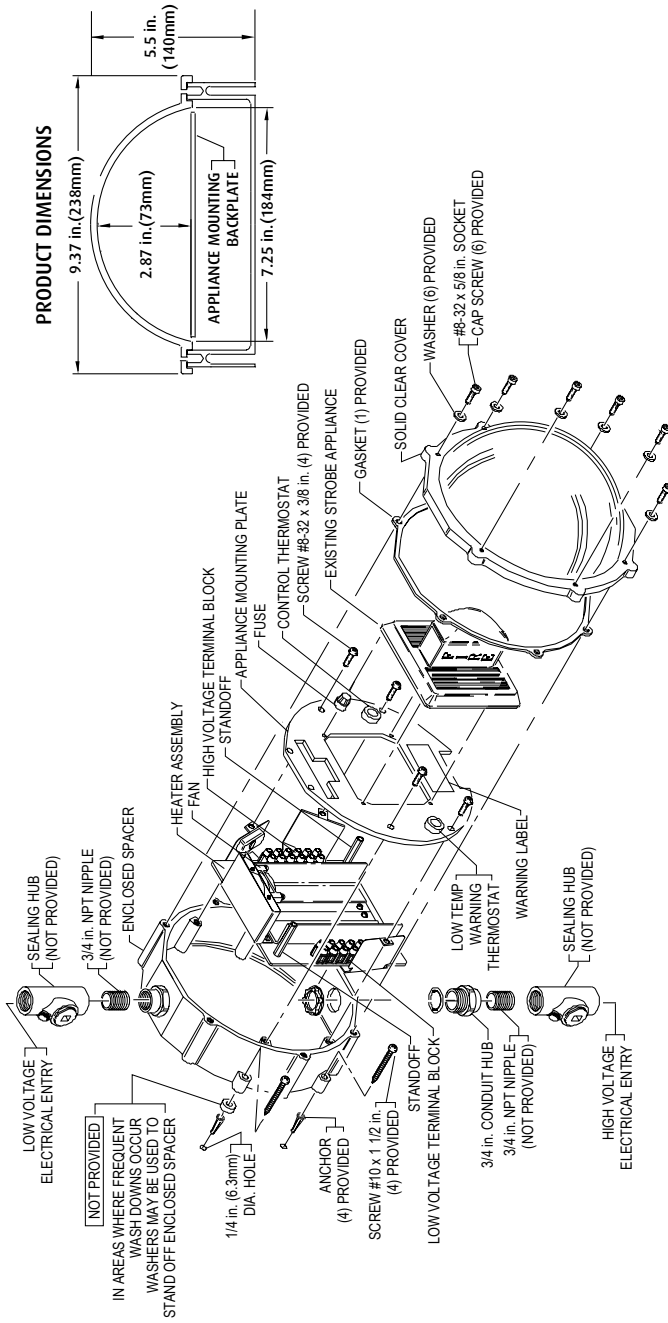

FIGURE 4

Warranty

⚠ WARNING: This product can expose you to chemicals including Dichloromethane, which is known to the State of California to cause cancer, and Bisphenol A (BPA), which is known to the State of California to cause birth defects or other reproductive harm.
For more information go to **www.P65Warnings.ca.gov**.

Three year warranty or a one year limited warranty (from date of purchase) on most products. See website for details.
Electronic warranty form at **www.sti-usa.com/wc14**.



USA



**Safety Technology
International**



EMEA

2306 Airport Rd • Waterford, MI 48327, USA
Phone: 248-673-9898 • info@sti-usa.com • www.sti-usa.com

Taylor House • 34 Sherwood Road • Bromsgrove, Worcestershire • B60 3DR • England
Tel: +44 (0)1527 520 999 • info@sti-emea.com • www.sti-emea.com

Unit 7A • Lockhead Avenue • Airport Business Park • Waterford • X91 HWF2 • Ireland
info@sti-emea.com • www.sti-emea.com