



Product Guide

Fire alarm solutions

for small and mid-size buildings



See what's possible now.

An **EDWARDS** brand.

Control Panels

Intelligent Addressable Devices

Conventional Initiating Devices

Notification Appliances

Door Holders & Relays



**Edwards Signaling: Building on a rich legacy of innovation.
Focused squarely on the future...**

Edwards Signaling offers total solutions that protect people and property with some of the most innovative fire alarm technology ever developed. From integrated life safety systems to intuitive programming and configuration, all of our products undergo rigorous scrutiny throughout their development to make sure they live up to the highest expectations of you, our customer. We invest this extra-effort with one simple goal in mind, to earn the right for our life safety solutions to be selected to maintain safe environments in some of the world's most important buildings – including yours.

When you invest in Edwards Signaling fire alarm products, you invest in a legacy that spans 140 years of innovation, and a team of dedicated people focused squarely on the future. We're already at the forefront of emerging new technologies. And we're investing heavily in fire alarm solutions that will make your world safer.

Product Guide:

Fire alarm solutions

for small and mid-size buildings

Fire Alarm Product Guide

Life safety solutions for small and midsize buildings

© 2013 UTC Fire & Security Americas Corporation, Inc.
All rights reserved.

3 Farm Glen Boulevard, Farmington, CT 06032

S85005-0132

Wiring diagrams provided herein are for information and reference only and are not to be used for installation purposes. Consult the appropriate installation documents for wiring and configuration details.

This guidebook is for information only and is not intended as a substitute for verbatim legislated requirements. For authoritative specifications regarding the application of life safety, security, and access control systems, consult current editions of applicable codes and standards. For authoritative interpretation of those codes and standards, consult your local authority having jurisdiction.

While every effort has been made to ensure the accuracy and completeness of this guidebook, the authors and publishers assume no responsibility for errors, inaccuracies, omissions, or any inconsistencies herein.

Genesis Series is a trademark of UTC.

Intelligent fire alarm systems for small to mid-sized buildings



With control panels, devices, and accessories all engineered to work in unison, Ed-

wards systems provide reliable performance and the advanced features you need for successful installation and worry-free operation. Best of all, Edwards leaves you in control – not hemmed in by a limited distribution product line. Edwards' extensive range of fire alarm products gives you the freedom to tailor each system to the particular needs of the building – and the budget of the building owner – while a robust feature set leaves plenty of room for upgrades, expansions, and retrofits long into the future.

But innovative features tell only part of the story: when you specify Edwards you're getting more than outstanding value in a fire alarm panel; you're benefitting from a whole family of control, detection, and notification appliances finely tuned to work together – engineered and tested to function as a single unified system.

Built on the successes of the past, and meeting the needs of the future, Edwards is the changing face of small to mid-size building fire detection today.

Control Panels & Accessories 1

Specifications	2
Intelligent Addressable Fire Panels	3
Intelligent Addressable Panel Modules	4
Remote Annunciators for Addressable Panels	6
Conventional Fire Alarm Control Panels	8
Conventional Panel Modules and Accessories	9
Booster Power Supplies	10
Control Panel Accessories	11

Addressable Initiating Devices 13

Detectors and Bases	14
Manual Pull Stations	17
Input/Output Modules	18

Conventional Initiating Devices 21

500 Series Smoke Detectors	21
700 Series Smoke Detectors	22
Beam Smoke Detectors	23
Heat Detectors	24
SuperDuct Duct Smoke Detectors	26
Carbon Monoxide Detector	27
Fire Alarm Stations	28
Harsh Environment Stations	30

Notification Appliances 31

Wall Strobes, Horns and Chimes	32
Wall Speakers and Speaker-strobes	34
Ceiling Speakers, Horns, and Strobes	35
Weatherproof Signals	36
Hazardous Location Horns and Strobes	37
Audio Notification System	38

Door Holders & Relays 39

Door Holders	39
Relays	39

Reference and Index 40

Specifications	p. 2
Intelligent Addressable Fire Panels	p. 3
Intelligent Addressable Panel Modules	p. 4
Remote Annunciators for Addressable Panels	p. 6
Conventional Fire Alarm Control Panels	p. 8
Conventional Panel Modules and Accessories	p. 9
Booster Power Supplies	p. 10
Control Panel Accessories	p. 11

Intelligent Control

Edwards life safety systems are a powerful intelligent solution for small to mid-sized buildings. The Edwards family includes intelligent addressable and conventional fire alarm control systems. A full line of remote annunciators, modules and accessories are available for both intelligent/addressable and conventional panels. Advanced technology delivers the benefits of flexible system installation, while a clean and easy-to-operate user interface makes panel operation and system maintenance quick and intuitive.

Flexibility built right in

Edwards programming features allow the system designer to customize powerful built-in features to precisely suit the needs of each building.

Intuitive software

The Edwards FSA-CU Configuration Utility is a windows based program used to configure system operation for

the Edwards E-FSC conventional and E-FSA addressable systems. The program can communicate remotely with a 56K Modem and optional DACT installed in the panel. It also can communicate with the addressable panels over RS-232 or Ethernet with optional modules. When used with the addressable panels, the Configuration Utility provides access to extensive reports and diagnostic tools. These reports and tools can be accessed remotely over the DACT or Ethernet modules.

Signals with a difference

Edwards NACs are configurable to fully support the advanced signaling technology of Genesis notification appliances. These devices offer precision synchronization of strobes to UL 1971 standards. For Genesis devices, enabling this feature allows connected horns to be silenced while strobes on the same two-wire circuit continue to flash until the panel is reset.

Clear-cut remote annunciation

Remote annunciation is a strong suit of Edwards intelligent panels. Up to eight annunciators can be installed on a single addressable system. Compatible annunciators include a range of LED and LCD models that provide zone or point annunciation, as well as common control capabilities.

Edwards also supports graphic annunciation with optional Graphic Annunciator Interface (GCI) modules. Each interface provides common control, indicators, and 32 LEDs.

A complete line of accessories

Edwards fire and life safety systems are supported by a complete line of detectors, modules and related equipment, each of which is fully tuned and tested to operate in concert with one another to provide highly reliable service and years of trouble-free operation.



Specifications

Fire Alarm Control Panels

Intelligent addressable technology engineered and designed expressly for small building applications...

Optional second loop (XAL127 module added to FSA250)

Up to 20,000 feet of wiring per data loop

Up to 20,000 feet of wiring per data loop

Specifications	FSA64	FSA250
Device loops (support devices of any type)	1 loop Class B, Class A optional, supports up to 64 devices	Standard 1 loop (127) devices, expand to 2 nd loop for additional (127) devices, order XAL-127 loop expander.
Notification Appliance Circuits	2 Class B, Class A optional. Total Power available 3.75A FWR	4 Class B or 2 Class A. Total Power available 6.0A FWR
Front Panel LEDs	N/A	Optional (2) 16-LED modules for a total of (32) LEDs, order (1) or (2) DL16L-FA LED Expander Module(s)
Aux Power 1	Continuous circuit: 24 VDC nominal at 500 mA	
Aux Power 2	Resettable circuit: 24 VDC nominal at 500 mA	
Base Panel Current	Standby: 155 mA Alarm: 204 mA	Standby: 172 mA, Alarm: 267 mA
Battery Placement	Accommodates up to 11 Ah (p/n 12V10A) batteries. Use external cabinet for larger batteries (p/n BC-1R).	Accommodates up to 18 Ah (p/n 12V17A) batteries. Use external cabinet for larger batteries (p/n BC-1R).
Batteries	Maximum charging capacity = 26 Ah.	
Loop Circuit	Max. wire run twisted nonshielded pair or non-twisted nonshielded fully loaded with devices - #18 AWG - 5,172 ft., #16 AWG - 8,217 ft., #14 AWG - 13,609 ft. See Tech. Ref. #3101202 R2 for additional information. Paige wire number for twisted nonshielded pair #18 AWG - 493490-L, #16 AWG - 740208-L, #14 AWG - 493491-L (THHN or TFN in conduit can be used on loop circuits).	
Auxiliary Contacts	Alarm & Trouble: Form C 24 VDC @ 1 A (resistive load). Supervisory: Form A 24 VDC @ 1 A (resistive load)	
Environmental	Temperature: 0 to 49°C (32 to 120°F). Humidity: 0 to 93% RH, noncondensing	
Remote Annunciator	Panel supports 8 max, RS-485 Class B or A. Panel auxiliary power will support (3) LCD and/or LED Master units. Paige wire number for twisted nonshielded 4-conductor (data & power) FPLP #18 AWG - 494449 or #14 AWG - 740212-L.	
Correlation Groups	199, which matches Inputs (Detectors and/or Initiating Modules) to Outputs (Panel NAC, Addressable NAC Modules, Addressable Relays, Sounder Bases and/or Relay Bases)	

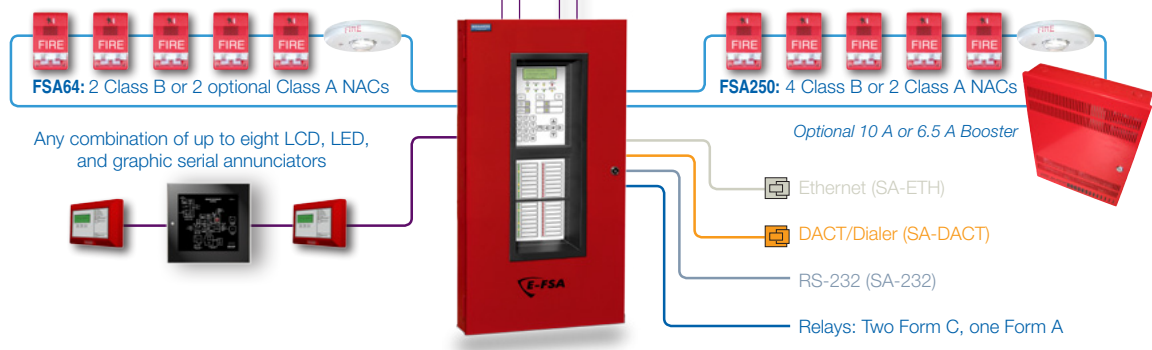
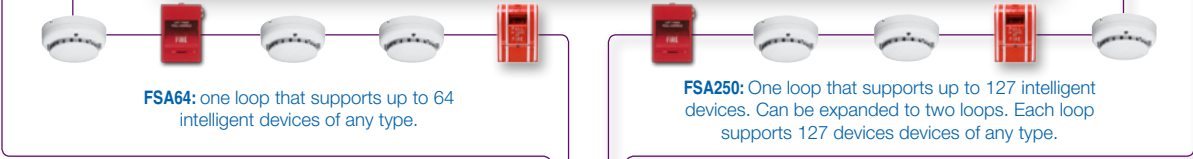

Intelligent Addressable Control Panels



Advanced intelligent addressable technology delivers the benefits of flexible system installation, while a clean and easy-to-operate user interface makes panel operation and system maintenance quick and intuitive.

The Edwards family of intelligent components also offers contractors and installers simple setup and installation, while delivering options that take full advantage of intelligent fire alarm processing. With a microprocessor in each device, intelligence is distributed throughout the system so that command decisions are made at the individual module, rather than bottlenecking at the control panel.

This not only speeds event processing, it also makes a more robust and reliable system – so robust, in fact, that when upgrading from a conventional panel to an Edwards intelligent system, you can usually use existing wiring – no twisted or shielded cable required!

Standard Features

The attractive appearance of Edwards control panels fits in any decor. Controls are discreetly inset behind the window.

- Sized to fit your needs: E-FSA64 - 64 points or E-FSA254 - 127 points. Expandable to 254 points.
- Supports up to eight serial annunciators, LCD, LED, and graphic interface
- 4 x 20 character, backlit LCD display, with event details display
- User interface includes two programmable switches with LEDs and custom labeling
- Class B or A SLC standard on both E-FSA64 and E-FSA250
- Class B or A NAC and annunciator wiring on E-FSA250 panels, optional on E-FSA64
- WireSaver feature enables use of existing or new solid or stranded fire wire, (up to 20K ft.)
- Form C contacts for alarm and trouble, Form A for supervisory
- Optional RS-232 printer/programming port
- Supports horn silence over two wires and UL

1971-compliant strobe synchronization with Genesis low profile notification appliances

- Fast ground-fault diagnostic mode
- Supports intelligent modules, pull stations, detectors,
- Programmable duct detector relay, sounder and relay bases
- Rotary addressing on all intelligent addressable devices
- Detailed module personality codes simplify programming
- Access panel programming and diagnostics locally or remotely via phone or IP
- Remote program read in any panel state
- Automatic drift compensation and two-level CleanMe® maintenance alert reporting on spot and duct detectors
- Detector Sensitivity level, alarm verification, and pre alarm set by point
- Day/Night sensitivity detector adjustment
- PinPoint enhanced ground-fault identification by circuit and module

Intelligent Single Loop Systems, Edwards data sheet number S85005-0131

E-FSA64*D	Fire Alarm Control Panel, Intelligent/Addressable, 64 Points, w/U/D Dialer, 24VDC	<input type="checkbox"/>
E-FSA64*	Fire Alarm Control Panel, Intelligent/Addressable, 64 Points, 24VDC	<input type="checkbox"/>
SA-TRIM1	Fire Alarm Control Accessory, Semi-Flush Mt., Trim Kit, E-FSA64*	<input type="checkbox"/>

Intelligent Two-Loop Systems, Edwards data sheet number S85005-0130

E-FSA250*D	Fire Alarm Control Panel, Intelligent/Addressable, 127 Standard up to 254 Points, w/U/D Dialer	<input type="checkbox"/>
E-FSA250*	Fire Alarm Control Panel, Intelligent/Addressable, 127 Standard up to 254 Points	<input type="checkbox"/>
D16L-FA	Remote Annunciator, LED, 16-Zone, 2-LEDs per Zone	<input type="checkbox"/>
SA-TRIM2	Fire Alarm Control Accessory, Semi-Flush Mt., Trim Kit, E-FSA250*	<input type="checkbox"/>

* Indicate color with R for red, G for gray, i.e. E-FSA64D, E-FSA250G

Dimensions

Panel dimensions, in (cm)									
	D1*	D2	D3	D4	D5*	D6	D7	D8	D9
E	21.50	3.85	7.5	15.5	14.25	10.25	3.9	21.7	2.7
-FSA64	(54.6)	(9.8)	(19)	(39.4)	(36.2)	(26)	(9.9)	(55.1)	(6.8)
E	28.0	3.85	9.0	22.0	15.75	10.25	3.9	28.2	2.7
-FSA250	(71.1)	(9.8)	(22.8)	(55.8)	(40.0)	(26.0)	(9.9)	(71.6)	(6.8)

* Optional trim kits provide 3/4" frame on top, bottom and sides of enclosure.

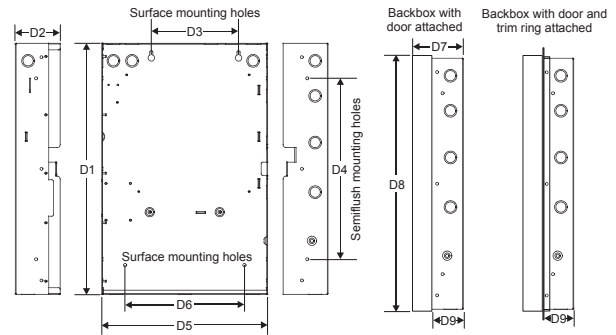

Option Cards

Edwards intelligent addressable panels are supported by a complete line of modules and related equipment that enhance performance and extend system capabilities. Option cards are easy to install and set up. They simply plug directly into the control panel main circuit board or are connected to it with a ribbon cable. After installation, terminals remain easily accessible for quick connection of field wiring. The cabinet provides ample room for wire routing, keeping wiring neat and easy to service at all times.

XAL127 Loop Expander Card

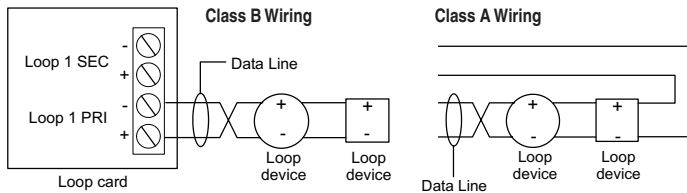

The XAL127 loop expander Card provides an additional device loop on the control panel. The card expands the control panel's device capacity to 254 total device addresses, 127 per loop. The card is compatible with Class B or Class A wiring. It is compatible with E-FSA250 control panels only. The loop expander card connects to connector J7 on the main circuit board.

The loop expander card connects to connector J7 on the main circuit board.

XAL127 SLC Loop Expansion Module. Adds second loop to E-FSA250 systems, 254 pt capacity. Mounts in cabinet on main board.

Data Sheet S85005-0130

SA-CLA Class A Module

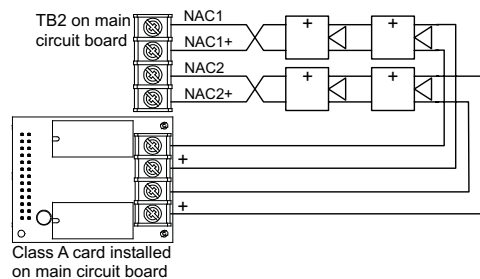

The SA-CLA card provides Class A capability for NAC and annunciator wiring. Its terminal block provides the wiring connection for NAC return wiring. The card is required for annunciator Class A wiring even though this wiring does not return to the SA-CLA card. The SA-CLA is compatible with E-FSA64 control panels only. E-FSA250 panels are Class A ready. The SA-CLA is installed directly to the control panel circuit board using its plastic standoffs and plug connection.

SA-CLA E-FSA64 Class A adapter module. Provides Class A capacity on NACs. Mounts in cabinet on main board.

Data Sheet S85005-0131

SA-ETH Ethernet Interface Card

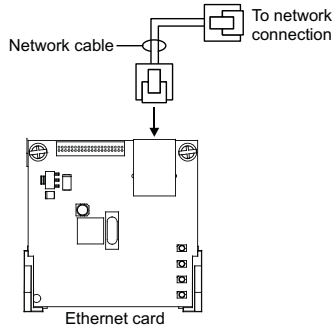

The SA-ETH card provides a standard 10/100 Base T Ethernet network connection for connecting to an intranet, a local network, or the Internet. The card can be used to upload and download panel configuration, history, and current status from the configuration utility to the panel over the network.

The Ethernet card is installed on the plastic assembly and connects to the main circuit board via a ribbon cable.

SA-ETH Ethernet Port for connection to local area networks. Mounts in cabinet on base plate. Data Sheet S85005-0131

SA-232 Serial Port (RS-232) interface

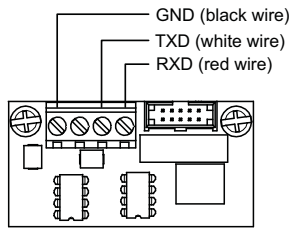

The SA-232 card provides an RS-232 interface with Edwards Intelligent Series panels. It can be used for connecting a printer to the control panel to print system events. The card also can be used for connecting a computer to download a configuration program from the configuration utility to the control panel.

The RS-232 card is installed on the plastic assembly and connects to the main circuit board via a ribbon cable.

SA-232 Serial Port (RS-232), for connection to printers & computers, mounts in cabinet to base plate. Data Sheet S85005-0131

260097 Upload/download cable from SA-232 card to PC, DB9 to wire leads

SA-DACT Upload/Download Dialer

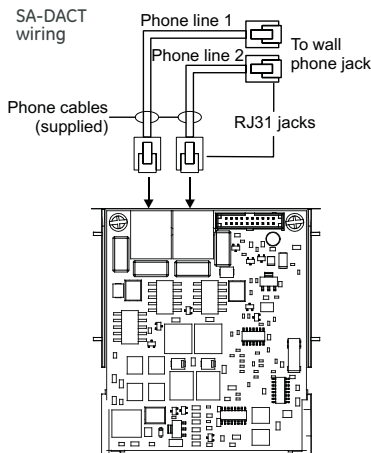

The SA-DACT provides communications between the control panel and the central station over a telephone line system. It transmits system status changes (events) to a compatible digital alarm communicator receiver over the public switched telephone network. The dialer is capable of single, dual, or split reporting of events to two different account and telephone numbers. The modem feature of the SA-DACT can also be used for remotely uploading and downloading panel configuration, history, and current status to a PC running the configuration utility. The 56K DACT/Modem can be configured for dual-line, single-line, or modem operation only.

The dialer phone lines connect to connectors on the dialer's main circuit board. Phone line 1 connects to connector J4 and phone line 2 connects to connector J1. The SA-DACT includes two RJ-31X cords with plugs at each end.

Note: All Edwards intelligent addressable fire panels can be ordered with the SA-DACT upload/download dialer included by ordering a panel with a "D" in the part number.

SA-DACT Dual Line Dialer/Modem, supports Contact ID, mounts in cabinet on base plate Data Sheet S85005-0131

Remote Annunciation



R-Series Annunciators are high-performance remote annunciators that provide status indication and common controls for Edwards Intelligent Addressable fire alarm systems. This family of annunciators offers LCD or LED annunciation as well as a graphic annunciator driver. Models are available with and without common controls.

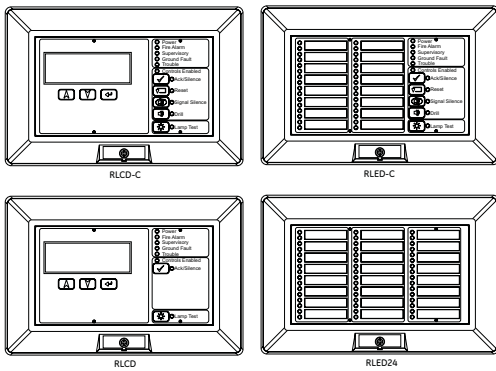

There are three R-Series annunciator models, plus an LED-based expander. Up to two expanders can be connected to any annunciator. The expander includes 24 pairs of LEDs that extend the capabilities of any of the annunciators.

All annunciator models include status LEDs and an internal buzzer. Two models have an LCD text display, and one has 16 pairs of LEDs for zone annunciation. LCD models feature a large back-lit, four by twenty character per line, super-twist liquid crystal display.

R-Series annunciators and expanders are mounted on a standard 4-inch square electrical box, using the included mounting ring. They can also be surface mounted in locking steel enclosures. Three different enclosures are available.

A keyswitch or locking enclosure are available for R-Series annunciator applications. The keyswitch enables or disables common controls. The key switch and locking enclosures limit access to the common controls to authorized personnel and may be required to meet NFPA requirements. The common controls on the E-RLCD-C can also be password protected.

Wiring, Class A

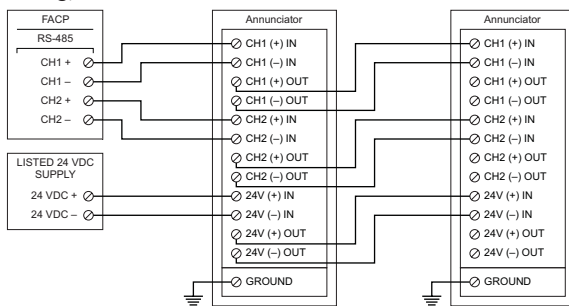

Wiring, Class B

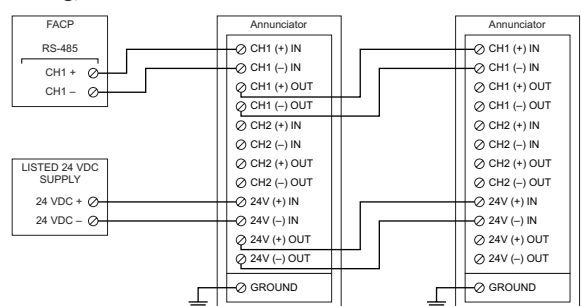

Remote Annunciators

<input type="checkbox"/>	RLCD-R	LCD text annunciator without common controls. Red.	Data Sheet S85005-0128
<input type="checkbox"/>	E-RLCD	LCD text annunciator without common controls. White.	Data Sheet S85005-0128
<input type="checkbox"/>	RLCD-CR	LCD text annunciator with common controls. Red.	Data Sheet S85005-0128
<input type="checkbox"/>	E-RLCD-C	LCD text annunciator with common controls. White.	Data Sheet S85005-0128
<input type="checkbox"/>	RLED-CR	16-pair LED zone annunciator with common controls. Red.	Data Sheet S85005-0128
<input type="checkbox"/>	E-RLED-C	16-pair LED zone annunciator with common controls. White.	Data Sheet S85005-0128

Remote Expanders

<input type="checkbox"/>	RLED24R	24-pair LED zone expander with expander cable and zone card insert. Red.	Data Sheet S85005-0128
--------------------------	---------	--	------------------------

Accessories

RKEY	Remote key switch on plate for enabling or disabling common controls (Lock/Unlock).	Data Sheet S85005-0128	<input type="checkbox"/>
RA-LED16ZC	Zone card insert for RLED-C, RLED-CR, and RLED-CF.	Data Sheet S85008-0128	<input type="checkbox"/>
RA-LED24ZC	Zone card insert for RLED24, RLED24R.	Data Sheet S85008-0128	<input type="checkbox"/>
27193-16	Surface Mount Box - Indoor, WHITE, 1-gang	Data Sheet S85008-0128	<input type="checkbox"/>
7300073	24-inch expander cable assembly, includes cable and hardware.	Data Sheet S85008-0128	<input type="checkbox"/>
7120313-01	12-inch expander cable (cable only).	Data Sheet S85008-0128	<input type="checkbox"/>
7120313-02	24-inch expander cable (cable only).	Data Sheet S85008-0128	<input type="checkbox"/>

R Series Annunciator Enclosures and Accessories

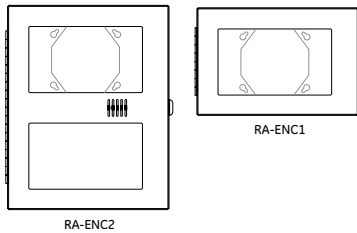

The RA Remote Annunciator Enclosures provide secure, surface mounted protection for annunciators and extenders. Each consists of a back plate, hinged cover, and key lock. The enclosures are 16-gauge welded steel with a white, painted finish. Each enclosure includes a security lock and two keys. The two- and three-position enclosures have wiring channels for correct routing of interconnections. The enclosures attach to a standard electrical box, and provide a mounting lip that takes the place of the integral mounting ring supplied with the annunciators and expanders.

RA-ENC1	One-position enclosure for Remote Annunciator.	Data Sheet S85005-0128	<input type="checkbox"/>
RA-ENC2	Two-position enclosure for Remote Annunciator and one Remote Expander.	Data Sheet S85005-0128	<input type="checkbox"/>
RA-ENC3	Three-position enclosure for Remote Annunciator and two Remote Expanders.	Data Sheet S85005-0128	<input type="checkbox"/>
LSRA-SB	Surface Mount Box	Data Sheet S85005-0128	<input type="checkbox"/>

GCI Graphic Annunciator Driver

The Graphic Annunciator Driver is an interface card that connects the Edwards Intelligent control panel to the display panel of an LED-based graphic annunciator (sold separately). The annunciator card supports 32 LEDs on the graphic panel display (E-FSA250) and 16 on E-FSA64. It includes status LEDs and an internal buzzer. The graphic interface is supplied with snap track mounting. It is attached to a plastic mounting rail that requires two EIA panels. The annunciator communicates with the control panel on the RS-485 data riser. This can be configured for Class A or Class B communication. The annunciator does not provide ground fault isolation. It is a stand-alone unit that can be powered by the control panel or by an approved power supply.



GCI	Graphic Annunciator Driver (Graphic Annunciator not included)	Data Sheet S85005-0128	<input type="checkbox"/>
-----	---	------------------------	--------------------------

Conventional Panels & Accessories



The Edwards conventional fire alarm family consists of 3-, 5- and 10- zone fire alarm control panels (FACP), an optional integrated upload/download DACT (dialer), intelligent/analog type detector features, serial annunciator modules, and serial remote relay modules. All FACP's and components are UL 864 Listed to the 9th edition standard.

Edwards incorporates features designed to simplify installation, operation and maintenance. These include front panel programming, one person walk testing, and selectable IDC and NAC types. In addition, when used with CleanMe® -compatible conventional smoke detectors, Edwards provides analog type features such as remote maintenance alert and automatic drift compensation that helps reduce false alarms and simplifies maintenance calls.

Edwards conventional panels are powerful enough to meet the demands of today's installations while leaving plenty of room to grow in the future. They support Class A operation by combining pairs of on-board IDCs or NACs to provide the necessary Class A circuits (5 and 10 zone panels only). For example, the E-FSC1004D comes factory set to support 10 Class B IDCs and 4 NACs. But it can be field-configured to provide 5 Class A IDCs (no Class B IDCs), and 2 Class A NACs – or any other combination of circuits that fall within the circuit-pairing parameters. Additionally, the E-FSC1004 10 zone panel can be expanded to 7.0 amps of signal power with the addition of an F-XTR120 transformer.

	E-FSC1004	E-FSC502	E-FSC302
Class B IDCs	Up to 10	Up to 5	3
Class A IDCs	Up to 5	Up to 2	0
Class B NACs	Up to 4	Up to 2	2
Class A NACs	Up to 2	1	0
NAC Power	7.0 amps	3.5 amps	3.5 amps
Auxiliary power	0.5 amps	0.5 amps	0.5 amps

Notes: Class A operation will reduce the number of available Class B IDCs and/or NACs, depending on the panel configuration. NAC power for E-FSC1004 is 3.5, expandable to 7.0 with optional F-XTR120. See catalog sheet S85005-0126 for details.

Conventional Fire Alarm Panels, Data Sheet S85005-0126

- E-FSC302*D Conventional Fire Alarm Control Panel with upload/download dialer – 3 Class B IDCs; 2 Class B NACs; 3.5A NAC power (Pairs of IDCs and NACs convertible to single Class A circuits); 120 Vac
- E-FSC502*D Conventional Fire Alarm Control Panel with upload/download dialer – 5 Class B IDCs; 2 Class B NACs; 3.5A NAC power (Pairs of IDCs and NACs convertible to single Class A circuits); 120 Vac
- E-FSC1004*D Conventional Fire Alarm Control Panel with upload/download dialer – 10 Class B IDCs; 4 Class B NACs; 7.5A NAC power (Pairs of IDCs and NACs convertible to single Class A circuits); 120 Vac

Note: Remove "D" from part number to order panels without UD dialer. UD dialer also sold separately under part number F-DACT.
 * Indicate color with G for gray, R for red, i.e. E-FSC302GD, E-FSC1004R, etc.

Semi-flush Trim Rings (for recessed mounting)

- F-TRIM35* Semi-flush trim for E-FSC302* and E-FSC502* (* specify R for red, G for gray, i.e. F-TRIM35G)
- F-TRIM10* Semi-flush trim ring for E-FSC1004*D (* specify R for red, G for gray, i.e. F-TRIM10RD)

End of Line Resistor (Options & replacements) (Panels include one 4.7K UL listed resistor for each IDC and NAC)

- EOL3.6-1.1 Required UL listed End of Line Resistors – One 3.6K Ohm and one 1.1K Ohm. One required for each IDC configured as combination waterflow and supervisory.

Expander Transformer (for the 10-zone panel only)

F-XTR120	Expander Transformer - doubles the NAC power supply capacity from 3.5 amps to 7.0 amps.	<input type="checkbox"/>
----------	---	--------------------------

Off Premises Communications

F-DACT	Upload/download digital Communicator/modem/LCD module (Mounts in control panel)	<input type="checkbox"/>
CTM	City Tie Module (Requires 4" square or 2-gang North American electrical box)	<input type="checkbox"/>
RPM	Reverse Polarity Module (Requires MFC-A or other listed fire alarm enclosure)	<input type="checkbox"/>



FSRSI



FSRZI-A



FSRA10

Remote Annunciation, Data Sheet S85005-0126

FSRSI	Remote System Indicator – Includes LEDs for display of Power, Alarm, Supervisory, Trouble and Ground Fault, trouble sounder and silence/lamp test switch. Single gang trim plate included, multi-gang plates ordered separately. Mounts in a single or multi-gang North American electrical box.	<input type="checkbox"/>
FSRZI-A	Remote Zone Indicator – Includes red LEDs for five IDCs. Single gang trim plate included, multi-gang plates ordered separately. Mounts in single or multi-gang North American electrical box.	<input type="checkbox"/>
FSRZI-SA	Remote Zone Indicator – Includes LEDs for five IDCs. Single gang trim plate included, multi-gang plates ordered separately. Mounts in single or multi-gang North American electrical box. Jumper selected Alarm (red) or Supervisory (amber) indications.	<input type="checkbox"/>
FSRA10	Single Unit 10 zone remote annunciator for E-FSC1004, White	<input type="checkbox"/>
FSRA10C	Single Unit 10 zone remote annunciator for E-FSC1004, White (with common controls)	<input type="checkbox"/>
FSUIM	Graphic Driver/Interface - 9 relays and 5 switch inputs for common system indicators and control functions	<input type="checkbox"/>

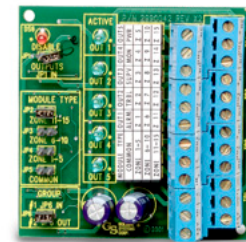

FSRRM24

Remote Relay Module, Data Sheet S85005-0126

FSRRM24	Remote Relay Module – Five Form C relays. Configurable for 1:1 operation with IDCs 1-5 or 6-10, matrix operation, or common system activation. Requires MFC-A or other listed fire alarm enclosure.	<input type="checkbox"/>
FSRRM-S11	11" Mounting track. Holds up to 4 FSRRM24s.	<input type="checkbox"/>

Mounting Accessories, Data Sheet S85005-0126

FSAT1	Annunciator Trim Plate, 1 gang, White. (Used with one FSRSI or FSRZI module.)	<input type="checkbox"/>
FSAT2	Annunciator Trim Plate, 2 gang, White. (Used with two FSRSI & FSRZI modules.)	<input type="checkbox"/>
FSAT3	Annunciator Trim Plate, 3 gang, White. (Used with three FSRSI & FSRZI modules.)	<input type="checkbox"/>
MFC-A	Multi-function Cabinet, red. Used for devices requiring a UL listed fire alarm accessory enclosure, such as RPM, FSUIM, FSRRM24	<input type="checkbox"/>

Power Supplies

Remote Booster Power Supply



The Remote Booster Power Supply is a self-contained 24 Vdc power supply designed to augment fire alarm audible and visual power requirements as well as provide power for auxiliary, access control and security applications. The booster contains all of the necessary circuits to monitor and charge batteries, control and supervise four Class B or two Class A NAC circuits and monitor two controlling inputs from external sources.

Simple switch selection provides a wide variety of operational configurations. Each remote booster power supply is supplied with its own enclosure providing ample space for additional interface modules and battery compartment. Will fit up to two 12V10A 11 amp hour batteries in cabinet.

When used with Genesis Notification appliances, the booster provides the ability to synchronize strobes as well as horn signals. The booster flexibility allows synchronization with upstream devices, or, the booster may be used to synchronize downstream devices, as well as other boosters and their connected devices.

BPS notification appliance circuits easily configure for either of two signaling rates: temporal 3 or continuous. This makes the BPS ideal for applications requiring signaling rates not available from the main panel. It also allows independent setup of a notification appliance circuit without interfering with the main panel and its initiating circuits. In addition to the generated signal rates, the BPS can also be configured to follow the signal rate of the main panel's notification appliance circuit. This allows seamless expansion of existing NACs.

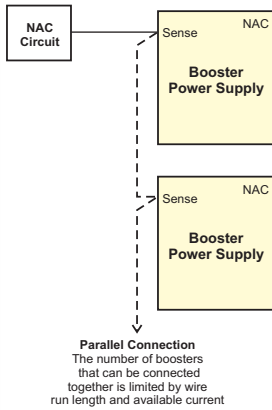

<input type="checkbox"/>	EBPS6A	6.5 Amp Booster Power Supply	Data Sheet S85005-0125
<input type="checkbox"/>	EBPS10A	10 Amp Booster Power Supply	Data Sheet S85005-0125



Batteries and Battery Cabinets

<input type="checkbox"/>	12 Volt Batteries	<input type="checkbox"/> 12V4A (4.5 Ah)	<input type="checkbox"/> 12V6A5 (7.2 Ah)	<input type="checkbox"/> 12V10A (11 Ah)
		<input type="checkbox"/> 12V24A (26 Ah)	<input type="checkbox"/> 12V17A (18 Ah)	
<input type="checkbox"/>	Battery Cabinet	<input type="checkbox"/> BC-1 (holds up to two 40 Ah batteries)		<input type="checkbox"/> BC-1R - Red

Accessories for Conventional and Addressable Panels

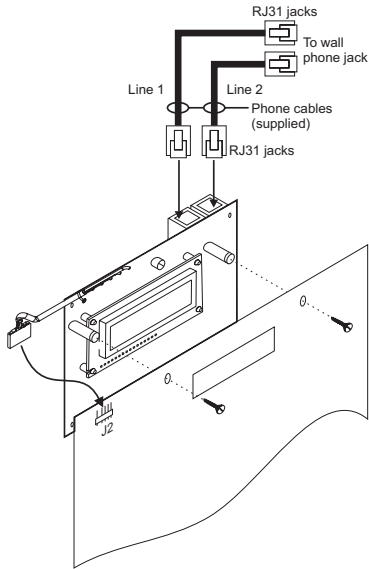

F-DACT dual line upload/download digital fire alarm communicator (for conventional panels only)

The F-DACT dialer is a multifunction module that provides communications, modem capability, and LCD display functions. Primarily a Digital Alarm Communicator Transmitter (DACT), it transmits event messages to a Digital Alarm Communicator Receiver (DACR) at a monitoring facility. The monitoring facility then notifies the fire department and other responsible parties of the event. Programmable options include split or dual reporting to two DACRs.

The DACT module can also be used as a modem to connect the panel to remote computers for uploading and downloading of configuration data (programming), panel status and event history. For security, the modem can be configured to accept programming on incoming calls or it can be required to call a preprogrammed number before accepting downloads and sending uploads.

The DACT module can be configured to work as all of the above, or as only an LCD display or LCD display and modem. It can be ordered separately or as part of the panel configuration by including a "D" in the panel part number.

F-DACT Upload/download digital fire alarm (mounts in control panel) [Data Sheet S85005-0126](#)



City Tie Module

The City Tie Module provides a simple way of connecting S to a local energy fire alarm box or City Master Box. One CTM provides either supervisory or alarm signaling. To configure both supervisory and alarm signaling, two City Tie modules are required. Each CTM connects to either a dedicated NAC on the panel or a dedicated NAC module.

CTM City Tie Module [Data Sheet S85005-0131](#)



Reverse Polarity Module

Provides three reverse polarity transmitters: one for system common alarm; one for system common trouble; and, one for system common supervisory.

RPM Reverse Polarity Module [Data Sheet S85005-0097](#)



Desktop Serial Printer (for addressable panels only)

The PT-1 series printers are high-speed, nine-pin dot matrix type. It is used to permanently record life safety system changes of state. All printed entries contain the date, time, event type and a user-defined message for each printed event. The printer is required in proprietary systems and requires a backup UPS power source. In auxiliary, local, or remote station systems, the printer is optional. Requires the SA-232 module.

PT-1S Serial Printer [Data Sheet S270020](#)

Detectors p. 14
 Detector Bases p. 15
 Duct Smoke Detectors p. 16
 Manual Pull Stations p. 17
 Input/Output Modules p. 18
 Related Equipment p. 20

Edwards

Intelligent Addressable Devices

Edwards brand intelligent addressable detectors are meticulously engineered to deliver high-performance features, superb reliability, and unbeatable quality. With their highly stable design, these detectors resist air movement caused by heating and air conditioning, making them reliable performers ideally suited to modern building interiors.

The installation and maintenance advantages of Edwards intelligent addressable detectors add value throughout their service life. The twist-and-lock design makes short work of installation and maintenance operations. A plastic breakout on the detector housing optionally prevents removal from the base except with a special tool.

A bright, dual color LED flashes red when the detector is in alarm, and green for normal polling, thus eliminating much of the guesswork when responding to front-panel indications.

Device loop

The E-FSA64 control panel provides one device loop circuit that supports 64 addresses. The E-FSA250 panel supports 127 addresses and can be expanded to provide a second loop of 127 addresses by means of the XAL127 SLC loop expansion module for a panel maximum of 254 addresses. All loop circuits are supervised for opens, shorts, and grounds. All addresses can be used for any device type maximizing loop flexibility.

Circuit specifications

Device loops	
E-FSA64	1 loop, supports up to 64 addresses, Class B or Class A
E-FSA250	1 loop, supports up to 127 addresses, Class B or Class A Optional 2nd loop supports up to 127 additional addresses, Class B or Class A

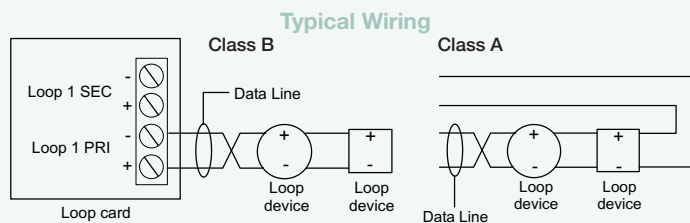

See page 4 for details concerning the XAL127 Loop Expansion Module.

All detectors feature comprehensive self-diagnostic capability. E-PD and E-PHD photoelectric detectors continuously adjust their sensitivity to compensate for changes in the environment such as the presence of dirt, smoke, temperature, and humidity. These detectors are factory set to issue a dirty sensor warning when they reach 80% of their compensation limit and a trouble condition when they reach 100%. The Edwards intelligent panel allows you to adjust the sensitivity settings during programming to meet the needs of the application.

Standard Features

- Photoelectric smoke detector, Photoelectric smoke & heat detector, and heat detectors available
- Compatible with standard, relay, isolator, and audible bases
- Field replaceable photoelectric chamber
- Simple rotary address setting
- Bases mount to standard North American two-gang or 4" square electrical boxes
- Dual color LED to differentiate between normal and alarm
- Tamper-resistant twist-and-lock installation feature
- Self diagnostic capability with on-board storage of results
- Factory-set to continuously adjust sensitivity to compensate for changes in the environment such as the presence of dirt, smoke, temperature, and humidity
- Manufactured to strict international ISO 9001 standards
- Assembled using surface mount technology for RF resistance
- Conformally coated components resist dust and humidity
- Automatic detector test
- Low profile detector and module design
- Panel is able to identify address of modules with ground fault on supervised field wiring
- Large selection of module types
- Module personality selection allows detailed information at panel and monitoring facility
- Command decisions are made at the module or detector decreasing response time
- Reuse existing, code compliant, electrically sound, untwisted, twisted or shielded wire

Intelligent Addressable Devices

Conventional Initiating Devices

Notification Appliances

Door Holders & Relays

Detectors



Photoelectric and combination detectors

Edwards photoelectric detectors continuously adjust their sensitivity based on fluctuating environmental conditions such as the presence of dirt, smoke, humidity, or changes in temperature, and notifies the panel of any changes in sensor sensitivity. When the detector has adjusted its sensitivity to its maximum limit, it issues a dirty sensor warning, allowing enough of a margin for maintenance personnel to clean the detector before it goes into trouble condition. These detectors perform comprehensive self-diagnostics and store these details in their on-board memory.

Photoelectric Smoke Detector

E-PD Photoelectric Smoke Detector uses an optical sensing chamber to detect smoke. The detector analyzes data gathered by the sensor to determine when an alarm is initiated. Thanks to its high-performance photoelectric sensing chamber, the E-PD responds quickly and reliably to a wide range of fire types, especially slow burning fires fuelled by combustibles typically found in modern multi-use buildings.

<input type="checkbox"/>	E-PD	Intelligent/Addressable Photoelectric Smoke Detector (Base sold separately)	Data Sheet S85001-0592
--------------------------	------	---	------------------------

Photoelectric/Fixed Temperature Detector

E-PHD Photoelectric/Fixed Temperature Detector houses a photoelectric sensing chamber that detects smoke, as well as a fixed-temperature sensor that detects heat.

<input type="checkbox"/>	E-PHD	Intelligent/Addressable Photoelectric Smoke/Heat Detector (Base sold separately)	Data Sheet S85001-0592
--------------------------	-------	--	------------------------

Heat Detectors

Thanks to advanced thermistor technology, Edwards heat detectors are ideal for sensing fast, flaming fires and for applications where smoke detection is inappropriate. They are particularly well suited for areas such as kitchens or harsh environments where the normal presence of smoke or dirt can cause smoke detectors to false alarm. These heat detectors are capable of performing comprehensive self-diagnostics and storing the results.



Fixed Temperature Heat or Rate-of-Rise Detector

E-HD Heat Detector is programmable as either a 135°F (57°C) fixed-temperature or 15°F (-9°C) degree per minute rate of rise heat sensor for the detection of heat due to fire. The heat sensor monitors the temperature of the air and determines whether an alarm should be initiated.

<input type="checkbox"/>	E-HD	Intelligent/Addressable Heat Detector (Base sold separately)	Data Sheet S85001-0592
--------------------------	------	--	------------------------

Addressable Detector Bases

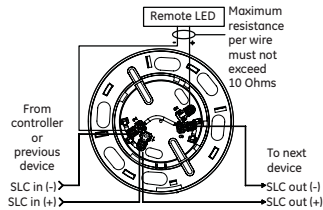
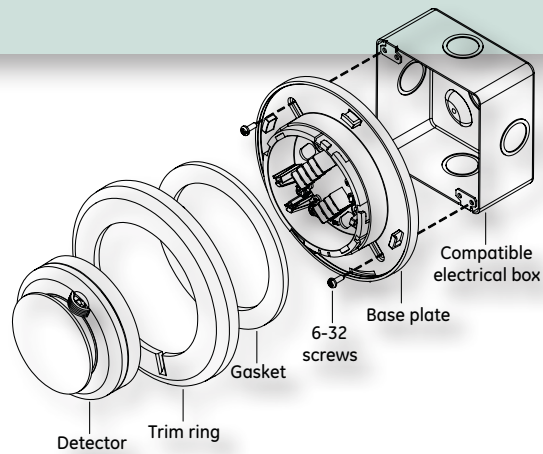

B4U Standard Base for Intelligent Addressable Detectors

The B4U Standard Detector Base features twist-and-lock detector installation and is compatible with Edwards Intelligent detectors. The base does not require a separate address because it shares the address of the device it is connected to.

B4U	Standard Base	Data Sheet S85001-0592	<input type="checkbox"/>
------------	----------------------	-------------------------------	--------------------------

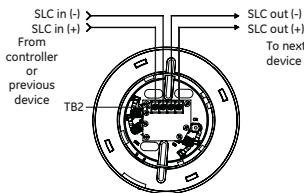

IB4U Isolator Detector Base for Intelligent Addressable Detectors

The IB4U Isolator Detector Base is designed to prevent an entire Class A communications loop from being disabled when a short circuit occurs. This is accomplished by isolating the part of the loop containing the short from the remainder of the circuit.

IB4U	Isolator Detector Base	Data Sheet S85001-0592	<input type="checkbox"/>
-------------	-------------------------------	-------------------------------	--------------------------

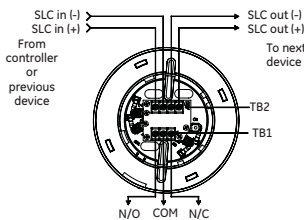

RB4U Relay Detector Base for Intelligent Addressable Detectors

The RB4U Relay Detector Base is designed to add relay functionality to the listed compatible detectors. Form C relay contacts are included for the control of appliances such as door closers, fans, dampers, etc. Relay bases may be configured for operation independent of the detector connected to the base.

RB4U	Relay Detector Base	Data Sheet S85001-0592	<input type="checkbox"/>
-------------	----------------------------	-------------------------------	--------------------------

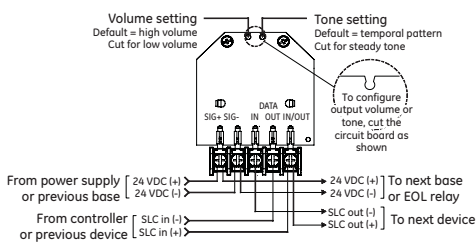

SB4U Audible (Sounder) Detector Base for Intelligent Addressable Detectors

The SB4U is designed to add an audible output function to compatible detectors. The base can operate as an independent local alarm, or as part of a zone or system alarm with synchronized audible output. The SB4U is field-configurable for output tone (steady or temporal) and output volume (low dBA or high dBA). The base must be connected to a continuous voltage whether the output tone is set to steady or temporal. The base does not require a separate address; it shares the address of the device it is connected to.

SB4U	Audible (Sounder) Detector Base	Data Sheet S85001-0592	<input type="checkbox"/>
-------------	--	-------------------------------	--------------------------

Accessories

AB4G-SB	Surface Box for Audible Base	Data Sheet S85001-0592	<input type="checkbox"/>
R-LED	Remote alarm LED. Use with standard base only.	Data Sheet S85001-0592	<input type="checkbox"/>
211-10PKG	Replaceable smoke det. optical chamber for E Series detectors; 10-Pack	Data Sheet S85001-0592	<input type="checkbox"/>

Note: 211-10PKG replaceable optical chamber is not compatible with the SuperDuct duct detector, optical beam detectors, and other smoke detectors not listed in description

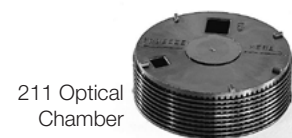

Intelligent Addressable Devices

Conventional Initiating Devices

Notification Appliances

Door Holders & Relays



SuperDuct Intelligent Duct Smoke Detectors

Less than two inches deep, SuperDuct Intelligent addressable smoke detectors are ideal for installation in ductwork, where space is always at a premium. Offering the most advanced and most reliable performance in its class, SuperDuct represents the perfect balance of practical design and advanced technology.

SuperDuct detectors feature a unique design that speeds installation and simplifies maintenance. Industry standard sampling tube mounting holes simplify retrofit applications. Removable dust filters, conformally coated circuit boards, and optional water-resistant gaskets keep contaminants away from components, ensuring years of trouble-free service. When cleaning is required, the assemblies come apart easily and snap back together in seconds. The relay output may be configured for operation independent of the duct detector.

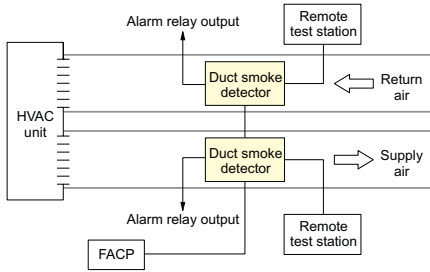

<input type="checkbox"/>	E-PDD	Intelligent Addressable SuperDuct Detector			Data Sheet S85001-0613
<input type="checkbox"/>	Sampling Tubes	<input type="checkbox"/> SD-T8 (8")	<input type="checkbox"/> SD-T18 (18")	<input type="checkbox"/> SD-T24 (24")	<input type="checkbox"/> SD-T36 (36")
		<input type="checkbox"/> SD-T42 (42")	<input type="checkbox"/> SD-T60 (60")	<input type="checkbox"/> SD-T78 (78")	<input type="checkbox"/> SD-T120 (120")
<input type="checkbox"/>	Remote Test Stations	<input type="checkbox"/> SD-TRM (magnetic)	<input type="checkbox"/> SD-TRK (keyed)	<input type="checkbox"/> R-LED (Remote alarm LED)	
<input type="checkbox"/>	Protective Housing	<input type="checkbox"/> SD-PH			
<input type="checkbox"/>	Accessories	<input type="checkbox"/> SD-MAG (Test magnet kit)			Data Sheet S85001-0613
		<input type="checkbox"/> SD-VTK (Air velocity test kit, stoppers only)			

Note: 211-10PKG replaceable optical chamber is not compatible with the E-PDD intelligent addressable duct detector

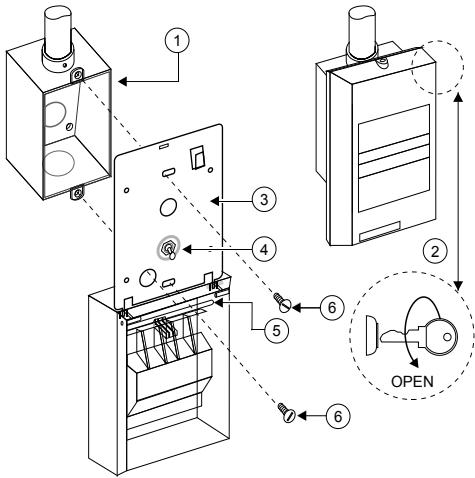

Manual Pull Stations

A single input mini module mounted on the back of the unit (factory installed) supervises the station and sends an alarm signal to the control panel when the switch is closed (i.e. when the handle is pulled). The device address is set using the two rotary switches located on the back of the unit. One device address is required. The pull station is configured for alarm latching operation. When the pull lever is activated, an alarm signal is sent to the control panel and the alarm condition is latched at the pull station.

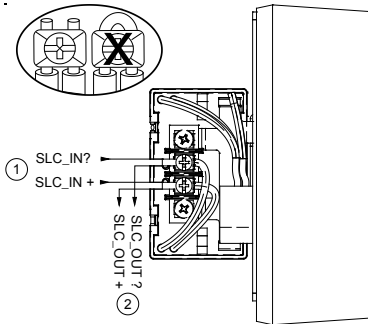

Addressable Double Action Pull Stations

The double action, single stage E-278 station is a contemporary style manual station made from durable red LEXAN. To initiate an alarm, first lift the upper door, then pull the alarm handle.



E-278	Double Action Fire Pull Station, Addressable, key reset	Data Sheet S85001-0612	<input type="checkbox"/>
276B-RSB	Surface Mount Box, Red — 278 series/E-278	Data Sheet S85001-0612	<input type="checkbox"/>
276-GLR	20 Break-rods — for 278 series, 20 Count	Data Sheet S85001-0612	<input type="checkbox"/>

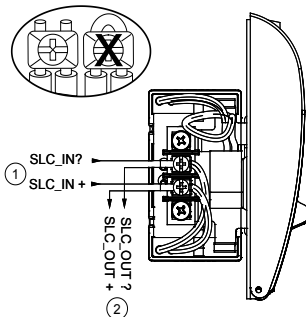

Addressable Single Action Pull Stations

E-270 series manual pull stations are made from die-cast zinc and finished with red epoxy powder-coat paint. With positive pull-lever operation, one pull on the station handle breaks the rod and turns in a positive alarm.



E-270	Single Action Fire Pull Station, Addressable, tool reset	Data Sheet S85001-0612	<input type="checkbox"/>
270-GLR	Pull Station Accessory, Glass Replacement Rods for 270/E-270 Series, 20 Count	Data Sheet S85001-0612	<input type="checkbox"/>
P-027193	Pull Station Accessory, Cast Mounting Box, 270/E-270 Series	Data Sheet S85001-0612	<input type="checkbox"/>
P-039250	Pull Station Accessory, Steel Mounting Box, 270/E-270 Series	Data Sheet S85001-0612	<input type="checkbox"/>

Intelligent Addressable Modules

Input/Output Modules



Standard Module



Mini Module

Edwards addressable modules are engineered to deliver high-performance features, superb reliability, and unbeatable quality. From control of ancillary equipment, to enhanced signaling functionality, these products add flexibility and powerful options to Edwards intelligent systems.

Edwards modules are addressable devices that are uniquely identified on the system by means of familiar rotary switches. Once registered, they share data and update status information that determines how the system behaves and how connected devices interact with one another.

Unique to Edwards modules is ground fault detection so precise that it actually pinpoints the specific module where the wiring problem has occurred. This saves hours of troubleshooting and wire tracing. And only Edwards provides this important feature!

The Edwards family of intelligent modules also offers contractors and installers simple setup and installation, while delivering options that take full advantage of intelligent fire alarm processing. With a microprocessor in each device, intelligence is distributed throughout the system so that command decisions are made instantly at the individual module, rather than bottlenecking at the control panel.

This not only speeds event processing, it also makes a more robust and reliable system – so robust, in fact, that when upgrading from a conventional panel to an Edwards intelligent system, you can usually use existing wiring – no twisted or shielded cable required!

E-IDC1B Single Input Mini Module

The E-IDC1B connects a normally open, alarm, supervisory, or monitor type dry contact initiating device circuit (IDC) to the Edwards control panel. This module is for Class B circuit operation. The device address is set using the two rotary switches located on the front of the module. One device address is required. The module is configured to operate as an alarm latching device type from the factory. When the NO contact of an initiating device is closed, an alarm signal is sent to the control panel and the alarm condition is latched at the module. Additional device types are available through front panel programming or the configuration utility. Refer to applicable control panel technical reference manual. The E-IDC1B includes two LEDs, green to indicate normal polling and red to show when the device is active.

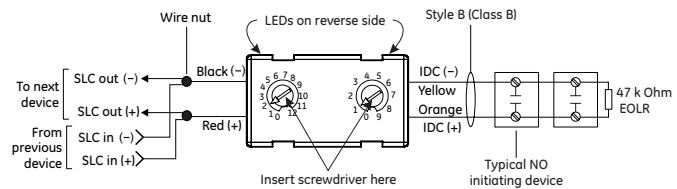

E-IDC1B

Single Input Mini Module (one-gang standard mount)

Data Sheet S85001-0611

E-IDC2B Dual Input Module

The E-IDC2B connects two normally open, alarm, supervisory, or monitor type dry contact initiating device circuits (IDCs) to the Edwards control panel. This module is designed for Class B circuit operation. The device address is set using the two rotary switches located on the front of the module. Two consecutive addresses are required. The second address is automatically assigned one number higher than the value set on the rotary switches. The E-IDC2B can be preset for alarm or supervisory operation using the slide switch located on the front of the module. It can also be configured for other device types through front panel programming or the configuration utility. The E-IDC2B includes a dual color LED, green to indicate normal polling and red to show when the device is active.

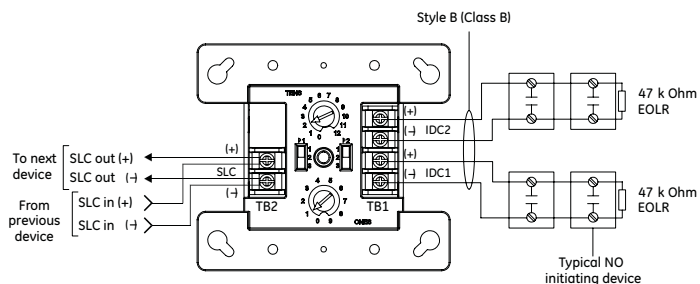

E-IDC2B

Dual Input Module (4x4 or two-gang standard mount)

Data Sheet S85001-0611

Class A-B Two-Wire Module

The E-2WIRE module interfaces between conventional two-wire smoke detectors and the E-FSA control panel. It monitors the circuit and smoke detectors, and signals the control panel of any trouble or alarm conditions. The module also regulates and supervises the 24 VDC input power. The E-2WIRE is configured to operate as a two-wire alarm device that does not require alarm verification. It can be set for two-wire alarm verified operation through front panel programming or the configuration utility. When using the alarm verification feature of the control panel, do not mix normally open contact initiating devices with two-wire conventional smoke detectors. The E-2WIRE can be set for Class B or Class A operation using the slide switch located on the front of the module.

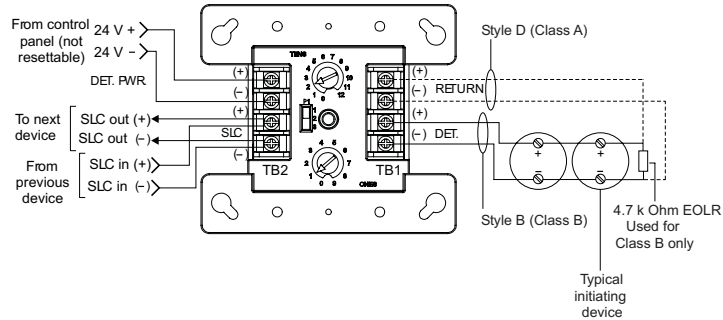

E-2WIRE Class A-B Two-Wire Module (4 x 4 or two-gang standard mount) Data Sheet S85001-0611

Waterflow/Supervisory Module

The E-IDCWS connects normally open waterflow alarm and supervisory initiating device circuits (IDCs) to the Edwards control panel. The E-IDCWS is designed for Class B circuit operation. The device address is set using the two rotary switches located on the front of the module. Two consecutive addresses are required. The first input address is fixed as waterflow and the second address is fixed as supervisory. The second address is automatically assigned one number higher than the value set on the rotary switches. The E-IDCWS includes a dual color LED, green to indicate normal polling and red to show when the device is active.

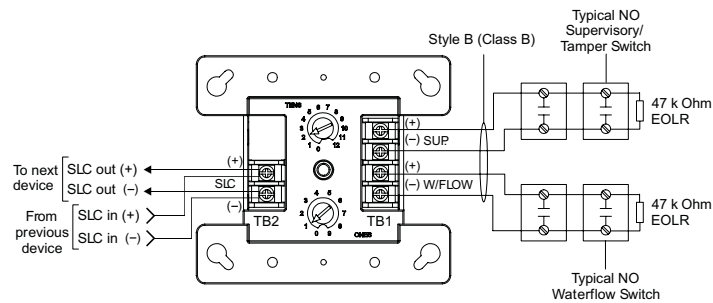

E-IDCWS Dual Input Waterflow, Supervisory Module (4 x 4 or two-gang standard mount) Data Sheet S85001-0611

E-ISO SLC Fault Isolator Module

The E-ISO isolator module is an intelligent device that allows part of the data loop to continue operating in the event of a short circuit. The module must be wired into a Class A data loop. A maximum of 64 isolator modules can be installed on one circuit. The E-ISO protects a Class A SLC from total collapse due to wire-to-wire short circuits. The module monitors line voltages and opens the SLC when a short is detected. A short is isolated between the two modules located electrically closest to the short. The device address is set using the two rotary switches located on the front of the module. One device address is required.

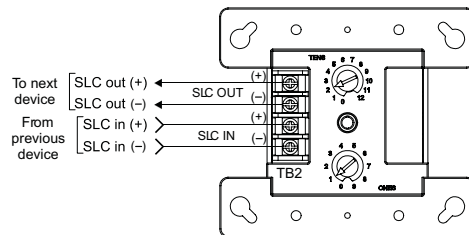

E-ISO SLC (Signalling Line Circuit) Fault Isolator Module (4 x 4 or two-gang standard mount) Data Sheet S85001-0611

Intelligent Addressable Output Modules

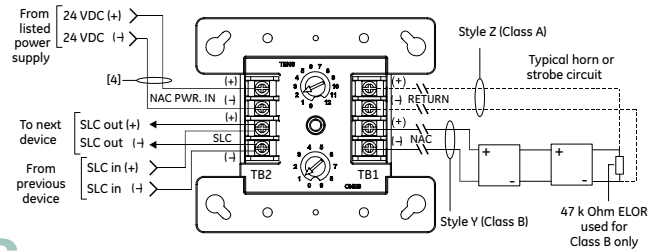

E-NAC Notification Appliance Circuit Module

The E-NAC connects a supervised output circuit to a signal riser. The output wiring is monitored for open and short circuits. A short circuit causes the module to inhibit the activation of the audible/visual signal circuit so the riser is not connected to the wiring fault. Upon command from the control panel, the module connects the output circuit to the riser input. The output circuit energizes a riser to operate polarized audible and visual signals. The module can be used for connection of a Class A or Class B (with EOL) output notification appliance circuit (NAC). When used with the EBPS Series power boosters, the E-NAC can also enable strobe synchronization of an entire building. Addressing the E-NAC is done with intuitive easy-to-use rotary dials.

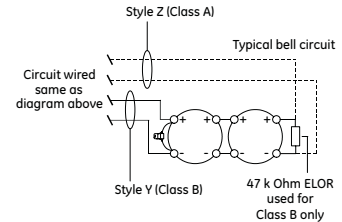

The 235196P transorb shown on drawing is required when electromechanical-type devices (like bells) are used.

E-NAC

Intelligent Notification Appliance (NAC) module

Data Sheet S85001-0611

E-RLY Contact Relay Module

The E-RLY provides one Form C dry relay contact. It can also be configured to provide polarity reversal of its output. The E-RLY can be used to control external appliances or shut down equipment. The E-RLY is wired according to its operation. It is configured to operate as a relay nonsilence device type, and can function as either a control relay or polarity reversal relay, depending on how it is wired. Control relay function: Provides one Form C dry relay contact. Polarity reversal relay function: Provides polarity reversal of its output.

Note: Additional device types are available through front panel programming or the configuration utility. Refer to applicable control panel technical reference manual.

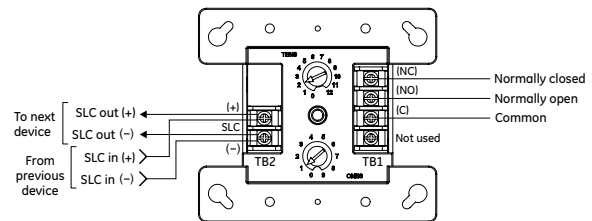

E-RLY

Intelligent Addressable Contact Relay Module

Data Sheet S85001-0611

Related Equipment

MFC-A	Multi-function Cabinet
27193-11	Surface Mount Box - Red, One-gang
27193-16	Surface Mount Box - White, One-gang
27193-21	Surface Mount Box - Red, Two-gang
27193-26	Surface Mount Box - White, Two-gang
235196P	Bi-polar Transient Protector (use when electromechanical devices, such as bells, are connected to E-NAC module)
EOL-4.7	EOL Resistor 4.7K, UL Listed
EOL-47	EOL Resistor, 47K, 1/2 watt, UL Listed
EOL-15	EOL Resistor, 15k, 1/2 watt, UL Listed



Conventional Initiating Devices



521B Smoke Detector

- 500 Series Heat Detectors p. 21
- 700 Series Heat Detectors p. 22
- Beam Smoke Detectors p. 23
- Heat Detectors p. 24
- SuperDuct Smoke Detectors p. 26
- Carbon Monoxide Detector p. 27
- Harsh Environment Stations p. 28
- Conventional Fire Alarm Stations p. 29

500 Series Smoke Detectors

Edwards brand 500 Series two-wire conventional photoelectric smoke detectors bring together trusted technology and a full line of features that meet the demands of every type of application. The 500 offers sounder models in two-wire applications, specifically to meet residential occupancy code requirements. The 500 Series also offers choices for optional auxiliary relays and isolated heat sensors.

Edwards is also proud to offer proven technology like CleanMe®, drift compensation, field replaceable optical chambers, and self-diagnostics. CleanMe® is only available on the 521 2-wire models and will communicate to the Edwards panels when servicing is required.

500 Series detectors work on a light-scattering principle. A pulsed infrared light-emitting diode serves as the light source, and a high-speed photo diode as the sensing element. This design has superior protection against nuisance alarms caused by dust, insects, RF interference, and ambient light.

The proprietary optical chamber is field replaceable. In the event of a confirmed alarm the LED will light continuously. The unit indicates trouble by flashing the LED every second. This meets the NFPA 72 field sensitivity testing requirements.

Units with built-in 85dBA sounders emit a temporal 3 tone pattern when in alarm and will emit a steady tone when the input power is reversed. All wiring terminates in clamp-type screw terminals. The detectors mount to a standard single-gang electrical box, a four-inch octagonal, four-inch square electrical box, or WIREMOLD(T) No. 5739 fixture box.

Standard Features

- CleanMe® remote maintenance reporting (521 models) and built-in drift compensation reduces false alarms
- Self-diagnostics eliminates the need for external meters
- Field-replaceable optical chamber makes service fast and simple
- Small, low profile design blends with any environment
- Optional auxiliary functions include:
 - Integral sounder
 - Fixed/Rate-of-Rise heats
 - Auxiliary relay

Detector Options Key

- N = Detector includes optional function
- B = 6-33VDC operation
- C = 8.5-33VDC operation
- R = Auxiliary relay
- S = 85dBa sounder
- XT = Rate-of-rise and fixed temp sensors

Two-Wire Models

511C	Photoelectric 2-Wire Smoke Detector, 12/24VDC. Not Listed MEA. S09A, S10A compatible	Data Sheet S85001-0595	<input type="checkbox"/>
521B	Photoelectric 2-Wire Smoke Detector w/CleanMe, 6/12 or 12/24VDC. S09A, S10A Compatible	Data Sheet S85001-0606	<input type="checkbox"/>
521BXT	Photoelectric 2-Wire Smoke Detector w/CleanMe and Heat Sensor, 6/12 or 12/24VDC.	Data Sheet S85001-0606	<input type="checkbox"/>
521NCRXT	Photoelectric 2-Wire Smoke Detector w/CleanMe, Heat Sensor and Auxiliary Relay, 12/24VDC.	Data Sheet S85001-0606	<input type="checkbox"/>
521NCSXT	Photoelectric 2-Wire Smoke Detector w/CleanMe, Heat Sensor and Sounder, 12/24VDC.	Data Sheet S85001-0606	<input type="checkbox"/>

700 Series Smoke Detectors

The 700 Series smoke detectors are the industry's first conventional self-diagnostic detectors specifically designed for the demands of commercial and industrial environments. If the detector drifts out of its UL Listed sensitivity range or fails internal diagnostics, the alarm LED flashes once a second to indicate trouble. This meets NFPA 72 field sensitivity testing requirements without the need for external meters.

The 700 series photoelectric smoke detector is an interchangeable head and base detector with a light-scattering optical sensor that provides outstanding stability and excellent response to a wide range of fires. The TS7 Series includes both the smoke detector head and base with SEM terminals packaged together.

Additional diagnostic information is activated by applying a magnet near the detector's integral reed switch. This initiates a self-diagnostic routine and provides visual indication of sensitivity level, or if service is required. The magnet test causes the LED to blink. The number of blink counts corresponds to a smoke detector sensitivity range.

And, if they become dirty over time, the 700 Series detectors automatically adjust the alarm threshold through built-in drift compensation.

Standard Features

- Self-diagnostic capability continually monitors operation
- Automatic drift compensation
- Field-replaceable optical chamber
- Low-profile design blends into the ceiling
- Advanced nuisance alarm immunity
- Extensive two-wire compatibility listings



Detectors with Packaged Bases: 2-Wire Conventional Smoke Detectors

<input type="checkbox"/>	TS7-2	2-Wire Detector, 12/24VDC. S10A Compatible, 711U Head w/701U Base	Data Sheet S85001-0600
<input type="checkbox"/>	TS7-2T	2 wire detector with heat sensor, 721UT head w/702U base	Data Sheet S85001-0600

Conventional Smoke Detector Accessories for 500, 700, and TS series (Data Sheet S85001-0600)

<input type="checkbox"/>	211-10PKG	Replaceable smoke detector optical chamber for E-PD, E-PHD, 500, 700, TS7; 10 pack
<input type="checkbox"/>	SM-200	Smoke! in a Can® (aerosol spray) for functional testing of smoke detectors; 12 pack
<input type="checkbox"/>	SM-XT1	Smoke! in a Can® aerosol test spray extension tube for use with SM-200-12PKG, aids in directing smoke flow

Note: 211-10PKG replaceable optical chamber is not compatible with the SuperDuct duct detector, optical beam detectors, and other smoke detectors not listed in description

700 Series Smoke Detector, heads only: 2-wire

(Data Sheet S85001-0598)

<input type="checkbox"/>	711U	2-Wire Fast Response Detector, 12/24VDC, S10A Compatible
<input type="checkbox"/>	721UT	2-Wire Fast Response Detector, w/Heat Sensors, 12/24VDC. S10A Compatible



700 Series Smoke Detector Bases, sold separately

(Data Sheet S85001-0598)

<input type="checkbox"/>	701U	6" Mounting Base for 711U and 711UT, 3 Terminals
<input type="checkbox"/>	702U	6" Universal Mounting Base, 700 Series, 6 Terminals for All Heads

701U 6-inch base
(for the 711U head)



Beam Smoke Detectors

EC Series Reflective Beam Smoke Detector

EC Series Reflective Beam Smoke Detectors comprise a transmitter and receiver in a single enclosure. The transmitter emits an invisible infrared light beam that is reflected via a prism mounted directly opposite and with a clear line of sight. Depending on the detector model, the prism can be mounted up to 160 feet – or as far away as 330 feet – from transmitter/receiver unit, and provide a protected area up to 60 feet wide.

This large protected swath makes EC Reflective Beam smoke detectors ideal for open areas such as warehouses, hotel atriums, industrial plants, and school gymnasiums. They are also invaluable in shopping malls, libraries, theatres and churches, where servicing traditional detectors can be difficult. Optional key-operated ground-level test stations allow remote detector testing from a safe location.

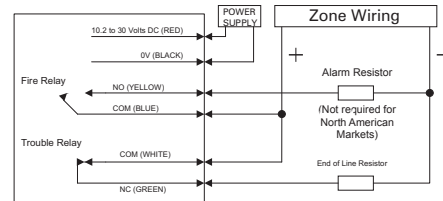
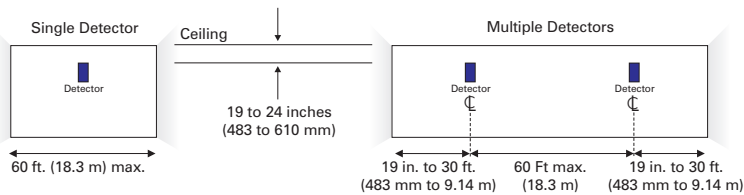

EC-50R	EC-50R Reflective Beam Smoke Detector, test filter, one reflector	Data Sheet S85001-0560	<input type="checkbox"/>
EC-100R	EC-100R Reflective Beam Smoke Detector, test filter, four reflectors	Data Sheet S85001-0560	<input type="checkbox"/>
EC-LLT	Ground Level Test Station	Data Sheet S85001-0560	<input type="checkbox"/>

Heat Detectors

Single Pole Heat Detectors

Edwards conventional heat detectors provide high quality, reliability, and the ultimate in design and decor. The low silhouette and pure white finish blends with most ceiling styles to provide an inconspicuous unit. Heat Detectors are available with 135°F, 194°F or 200°F ratings for fixed temperature, or combination rate-of-rise and fixed temperature operation. Both single pole and double pole models are available.



280B-PL

Rate-of-rise operation: a temperature increase at the detector of 15°F or more per minute activates the rate-of-rise feature. This closes the contacts in the detector to transmit the alarm condition to the fire alarm control panel. When the rate-of-rise element alone has been activated, the detector is self-restoring.

Fixed temperature operation: if the temperature of the center disk rises to the detector's rated temperature, the fixed temperature element activates. This closes contacts in the detector and transmits an alarm condition to the fire alarm control panel. The fixed temperature element is non-restorable and, when activated, the detector must be replaced. The need for replacement is indicated when the center disk has fallen free from the detector.

Note: Standard Plastic Mounting Plate Included with Each Heat Detector

<input type="checkbox"/>	281B-PL	Heat Detector, 135°F, combination rate-of-rise & fixed temperature	Data Sheet S85001-0261
<input type="checkbox"/>	282B-PL	Heat Detector, 194°F, combination rate-of-rise & fixed temperature	Data Sheet S85001-0261
<input type="checkbox"/>	283B-PL	Heat Detector, 135°F, fixed temperature	Data Sheet S85001-0261
<input type="checkbox"/>	284B-PL	Heat Detector, 194°F, fixed temperature	Data Sheet S85001-0261
<input type="checkbox"/>	280A-PL	Reversible Plastic Mounting Plate, White, for 280 Series Detectors	Data Sheet S85001-0261

Double Pole Heat Detectors

CR/CF Series Heat Detectors offer fixed temperature or combination rate-of-rise and fixed temperature detection.



CR-CF

Rate-of-rise operation: a temperature increase at the sensor of 15°F (9°C) or more per minute activates the rate-of-rise feature. This closes the contacts in the sensor to transmit the alarm condition to the fire alarm control panel. When the rate-of-rise element alone has been activated, the sensor is self-restoring.

Fixed temperature operation: if the temperature of the center disk rises to the sensor's rated temperature, the fixed temperature element activates. This closes contacts in the sensor and transmits an alarm condition to the fire alarm control panel. The fixed temperature element is non-restorable and, when activated, the detector must be replaced. The need for replacement is indicated when the center disk has fallen free from the detector.

<input type="checkbox"/>	CR135-2	Heat Detector, 135°F (57°C), combination rate-of-rise & fixed temperature	Data Sheet S85001-0367
<input type="checkbox"/>	CR200-2	Heat Detector, 200°F (93°C), combination rate-of-rise & fixed temperature	Data Sheet S85001-0367
<input type="checkbox"/>	CF135-2	Heat Detector, 135°F (57°C), fixed temperature only	Data Sheet S85001-0367
<input type="checkbox"/>	CF200-2	Heat Detector, 200°F (93°C), fixed temperature only	Data Sheet S85001-0367

Rate compensation heat detectors for indoor, all weather & hazardous environments

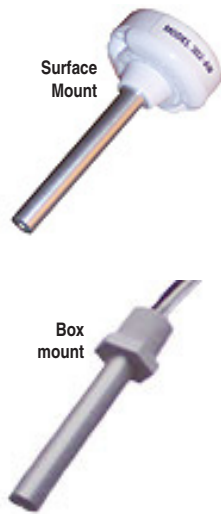

Series 302 heat detectors are designed for use in normal environments as well as environments where the detectors are subject to weather, moisture (internal condensation), and explosive atmospheres. They are normally-open devices designed to close an electrical circuit upon activation. All models feature rate compensation and are available with either 135 °F (57.2 °C) or 194 °F (90 °C) ratings. They are self restoring, hermetically sealed, shock and corrosion resistant, and are tamperproof.

Sensors rated at 135 °F (57.2 °C) will not respond to momentary temperature fluctuations less than 30 °F/minute between 60 °F (16 °C) and 100 °F (38 °C). Sensors rated at 194°F (90 °C) will not respond to momentary temperature fluctuations less than 50 °F/minute between 60 °F (16 °C) and 150 °F (66 °C). 302 Series sensors should not be used in environments where conditions exceed these parameters. Do not install them in hot air ducts, in front of heaters, in paint booths that use heat to cure paint, or any other location subject to temperature fluctuation.

Sensor's Rated Temperature	Minimum Ambient Air Temperature	Maximum Ceiling Temperature
135 °F (57.2 °C)	-40 °F (-40 °C)	100 °F (38 °C)
194 °F (90 °C)	-40 °F (-40 °C)	150 °F (66 °C)

The sensor's aluminum tube acts as a heat collector when sources of heat radiate directly on the tube. Install these sensors out of direct sunlight and away from radiating heat sources including the direct flow from heaters and heat ducts.

Indoor

302-135	Heat Detector, rate compensated, 135F 57.2C	Data Sheet S85001-0589	<input type="checkbox"/>
302-194	Heat Detector, rate compensated, 194F 90.2C	Data Sheet S85001-0589	<input type="checkbox"/>

All Weather

302-AW-135	All-weather Heat Detector - Vertical Mounting FM & UL, 135 °F (57.2 °C)	Data Sheet S85001-0589	<input type="checkbox"/>
302-AW-194	All-weather Heat Detector - Vertical Mounting FM & UL, 194°F (90 °C)	Data Sheet S85001-0589	<input type="checkbox"/>
302-ET-135	All-weather Heat Detector - Vertical, Box Mount (½" NPT), FM & UL, 135 °F (57.2 °C)	Data Sheet S85001-0589	<input type="checkbox"/>
302-ET-194	All-weather Heat Detector - Vertical, Box Mount (½" NPT), FM & UL, 194°F (90 °C)	Data Sheet S85001-0589	<input type="checkbox"/>

Hazardous Location

302-EPM-135	Heat Detector - Explosionproof Mounting UL (Not FM approved), 135 °F (57.2 °C)	Data Sheet S85001-0589	<input type="checkbox"/>
302-EPM-194	Heat Detector - Explosionproof Mounting UL (not FM approved), 194°F (90 °C)	Data Sheet S85001-0589	<input type="checkbox"/>

Rate Compensation Heat Detector Accessories



AP-P	Adaptor plate, white, plastic. Mounts 302 & 302-AW to 3" outlet or 4" (octagon) box.	Data Sheet S85001-0589	<input type="checkbox"/>
STONCO27	3 ½" Weatherproof, round backbox and cover (½" thread hubs)	Data Sheet S85001-0589	<input type="checkbox"/>
JALX11	Explosion proof outlet body with cover (½" thread hubs) - Killark	Data Sheet S85001-0589	<input type="checkbox"/>

SuperDuct Duct Smoke Detectors

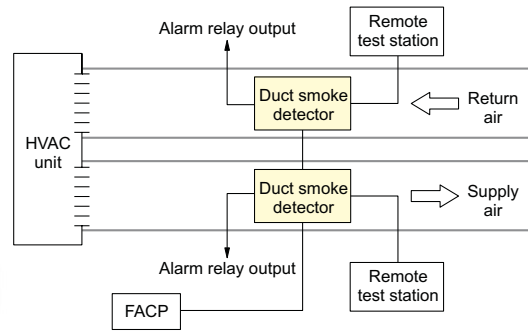

SuperDuct Conventional Duct Smoke Detectors

Less than two inches deep, SuperDuct smoke detectors are ideal for installation in ductwork, where space is always at a premium. Offering the most advanced and most reliable performance in its class, SuperDuct represents the perfect balance of practical design and advanced technology.

SuperDuct detectors feature a unique design that speeds installation and simplifies maintenance. Industry standard sampling tube mounting holes simplify retrofit applications. The relay output may be configured for operation independent of the duct detector. A dedicated dirty/trouble LED on each unit offers immediate at-a-glance information even when the cover is closed.

Controller can be installed up to 15 feet from detector and one controller can support up to two detectors. Up to 15 controllers can be interconnected for multiple fan shut-down.

<input type="checkbox"/>	SD-2W	Conventional 2-wire Duct Detector	Data Sheet S85001-0585
<input type="checkbox"/>	SD-4WJ	Conventional 4-wire Duct Detector Controller with sensor	Data Sheet S85001-0583
<input type="checkbox"/>	SD-CJ	Duct Detector, Controller Only, RJ45	
<input type="checkbox"/>	SD-CT	Duct Detector, Controller Only, Terminals	
<input type="checkbox"/>	SD-SJ	Duct Detector, Sensor Only, 4-Wire, RJ45	
<input type="checkbox"/>	SD-ST	Duct Detector, Sensor Only, Terminals	
<input type="checkbox"/>	Sampling Tubes	<input type="checkbox"/> SD-T8 (8") <input type="checkbox"/> SD-T18 (18") <input type="checkbox"/> SD-T24 (24") <input type="checkbox"/> SD-T36 (36") <input type="checkbox"/> SD-T42 (42") <input type="checkbox"/> SD-T60 (60") <input type="checkbox"/> SD-T78 (78") <input type="checkbox"/> SD-T120 (120")	
<input type="checkbox"/>	Remote Test Stations for 4 wire	<input type="checkbox"/> SD-TRM4 (magnetic) <input type="checkbox"/> SD-TRK4 (keyed)	
<input type="checkbox"/>	Remote Test Stations for 2 wire	<input type="checkbox"/> SD-TRM (magnetic) <input type="checkbox"/> SD-TRK (keyed)	
<input type="checkbox"/>	R-LED	Remote Alarm LED	
<input type="checkbox"/>	Accessories	<input type="checkbox"/> SD-GSK (cover gasket kit) <input type="checkbox"/> SD-MAG (Test magnet kit) <input type="checkbox"/> SD-VTK (Air velocity test kit, stoppers only) <input type="checkbox"/> SD-PH Protective Housing	
<input type="checkbox"/>	SD-RJ15	RJ45 wiring harness kit -- 15 ft. 1.5 (0.7)	
<input type="checkbox"/>	SD-RJ10	RJ45 wiring harness kit -- 10 ft. 1.5 (0.7)	
<input type="checkbox"/>	SD-RJ5	RJ45 wiring harness kit -- 5 ft.	
<input type="checkbox"/>	6263-EC	Air Velocity Test Kit	
<input type="checkbox"/>	EC-LED	Fire Alarm LED Indicator	
<input type="checkbox"/>	C-DTS	Fire Alarm LED/Test Station	



Carbon Monoxide Detector

The next generation SafeAir™ 250-CO carbon monoxide (CO) detector is an accurate and reliable means of alerting building occupants of potentially dangerous levels of CO in the protected area. The internal electro-chemical sensor communicates with a sophisticated on-board microprocessor that accurately tracks CO levels over time. The 250-CO continues SafeAir's proven legacy of more than one million 240-COe carbon monoxide detectors installed over a decade.

This commercial-grade detection technology results in quick response, reliable sensing, fast reset time, and superior false alarm immunity. Its small size allows the 250-CO to blend inconspicuously with any decor, and its smooth contoured design is compatible with both residential and commercial environments. The 250-CO detector can connect to either UL 985 (Household Fire Warning) or UL 864 (Commercial Fire) control panels. It is not intended for use in industrial applications such as gasoline refineries or parking garages, which require different listings.

Unaffected by normal indoor temperature variations, the 250-CO actually self-adjusts for environmental changes and operates reliably under a wide variety of conditions. It also monitors its own performance and automatically compensates for sensitivity drift throughout the course of its service life.

Like all CO detectors, the 250-CO has a limited service life. When it reaches this point, the 250-CO's six-year end-of-life timer automatically triggers a warning, locally, at the control panel, and optionally, at a central monitoring station, indicating that the device must be serviced.

An integrated temporal four-horn provides local signaling capability for the 250-CO, and it easily interfaces with any Listed intrusion or fire alarm system by means of its 150mA output relay, which may be connected to the auxiliary input on the control panel. Its low current draw results in little additional demand on the system power supply.

The 250-CO fully complies with the latest UL 2075 requirements which allows for installation in a wide range of residential and commercial settings.

Standard Features

- Uses highly reliable, commercial-grade, electro-chemical sensing technology
- Self-diagnostics keep the device operating optimally throughout its service life
- Sensor is unaffected by fluctuations in normal indoor temperature
- Built-in trouble/power supervision relay
- 12 or 24VDC operation and 150mA relay contact configurable for normally open or normally closed operation
- Long-life six-year sensor
- Transmits sensor end-of-life to the control panel and central station if the system is monitored
- Fully listed to the latest UL 2075 CO standard for residential or commercial occupancies
- Large terminals ease wiring installation 14 to 22 AWG
- One-touch TEST/HUSH button simplifies local operation
- Integrated 85 dBA temporal 4-sounder for local notification
- On-board LED provides local alarm and trouble indication
- Inconspicuous footprint and attractively contoured design
- Replacement for SafeAir 240-COe detector (optional adaptor plate available)

Data Sheet S85001-0618

250-CO	SafeAir™ 250-CO carbon monoxide detector, alarm & trouble relays, sounder, end-of life signal, 12/24VDC	<input type="checkbox"/>
250-COPLT-5PKG	Adaptor plate for use when replacing the legacy SafeAir 240-COe detector with new and improved SafeAir 250-CO	<input type="checkbox"/>

Conventional Manual Stations



Manual Pull Stations - Single Action Metal

The 270 Series non-coded fire alarm conventional pull stations are sturdy, attractive, and designed for economical installation. 270 Series provide a single action, break glass initiating station. It is available with normally open, normally closed or combination NO/NC contacts. 270 Series have screw terminals for field connection. 270A Series have 6-inch wire leads.

<input type="checkbox"/>	<input type="checkbox"/> 270-SPO (w/ terminals)	<input type="checkbox"/> 270A-SPO (w/ wire leads)	Single-action pull station, single normally open	Data Sheet S85001-0303
<input type="checkbox"/>	<input type="checkbox"/> 270-DPO (w/ terminals)	<input type="checkbox"/> 270A-DPO (w/ wire leads)	Single action pull station, double normally open	Data Sheet S85001-0303
<input type="checkbox"/>	<input type="checkbox"/> 270-DOC		Single action pull station, normally open / normally closed	Data Sheet S85001-0303
<input type="checkbox"/>	<input type="checkbox"/> 270-GLR		Glass rods for 270 Series manual stations	Data Sheet S85001-0183



Manual Pull Stations - Single/Double Action Lexan®

276B/277B Series non-coded fire alarm stations are contemporary styled Lexan stations that are flexibly designed to meet a wide variety of application requirements and operational sequences.

- 276B Series are single action stations with terminals for field wiring connections.
- 277B Series are also single action stations but use 6" wire leads for field wiring connections.
- 278B Series are double action stations with terminals for field wiring connections.
- 279B Series are double action stations with 6" wire leads for field wiring connections.

Available with single or double pole alarm contacts that can be normally open, normally closed or a combination of both. Either a key or tool (depending on station selected) is required to reset pull station.

<input type="checkbox"/>	276B-1120	Single action, 1 stage, key reset, terminals, single pole	Data Sheet S85001-0183
<input type="checkbox"/>	276B-1110	Single action, 1 stage, tool reset, terminals, single pole	Data Sheet S85001-0183
<input type="checkbox"/>	277B-1110	Single action, 1 stage, tool reset, wire leads, single pole	Data Sheet S85001-0183
<input type="checkbox"/>	278B-1420	Double action, 1 stage, double pole, leads, key, reset, 1 open & 1 closed contact	Data Sheet S85001-0227
<input type="checkbox"/>	278B-1120	Double action, 1 stage, single pole, key reset, terminals	Data Sheet S85001-0227
<input type="checkbox"/>	278B-1110	Double action, 1 stage, single pole, tool reset, terminals	Data Sheet S85001-0227
<input type="checkbox"/>	279B-1110	Double action, 1 stage, single pole, tool reset, wire leads	Data Sheet S85001-0227
<input type="checkbox"/>	276-GLR	Pull Station Accessory, Plastic Replacement Rods for 276/278/279, 20 Count	Data Sheet S85001-0227

Harsh Environment Manual Stations



Weatherproof Manual Stations

MPSR Series manual pull stations are noncoded fire alarm stations solidly constructed of die-cast material. All components are pre-painted or have plated surfaces to inhibit corrosion. MPSR Series manual pull stations are weatherproof and rated for outdoor use. Single- and double-action MPSR models are available with either single pole (normally open) or double pole (double throw) alarm contacts. Depending on the model, access to the unit for resetting purposes is gained with either a keylock or hex screw. All models feature terminals for wire connection.

Single Action Stations (weatherproof backbox included)

MPSR1-SHTW-GE	SPST, hex screw reset, terminal connections.	Data Sheet S85001-0588	<input type="checkbox"/>
MPSR1-S45W-GE	SPST, Cat 45 Key reset, terminal connections.	Data Sheet S85001-0588	<input type="checkbox"/>
MPSR1-DHTW-GE	DPDT, hex screw reset, terminal connections.	Data Sheet S85001-0588	<input type="checkbox"/>
MPSR1-D45W-GE	DPDT, Cat 45 Key reset, terminal connections.	Data Sheet S85001-0588	<input type="checkbox"/>

Double Action Stations (weatherproof backbox included)

MPSR2-SHTW-GE	SPST, hex screw reset, terminal connections.	Data Sheet S85001-0588	<input type="checkbox"/>
MPSR2-DHTW-GE	DPDT, hex screw reset, terminal connections.	Data Sheet S85001-0588	<input type="checkbox"/>
MPSR2-S45W-GE	SPST, Cat 45 Key reset, terminal connections.	Data Sheet S85001-0588	<input type="checkbox"/>
MPSR2-D45W-GE	DPDT, Cat 45 Key reset, terminal connections.	Data Sheet S85001-0588	<input type="checkbox"/>
MPSR2-SHTW-GE-NYW	SPST, hex screw reset, terminal connections, NYC white stripe.	Data Sheet S85001-0588	<input type="checkbox"/>
MPSR2-S45W-GE-NYW	SPST, Cat 45 Key reset, terminal connections, NYC white stripe.	Data Sheet S85001-0588	<input type="checkbox"/>

Manual Station Accessories

P-024953	Key - for Presignal Manual Pull Stations	<input type="checkbox"/>
276-K1	Reset Key & Tag (for 270 Series Key-Reset Stations)	<input type="checkbox"/>
276B-RSB	Surface Back Box - Red, Steel; for 270 Series Stations	<input type="checkbox"/>
P-027193	Surface Box, Cast	<input type="checkbox"/>
P-039250	Surface Box	<input type="checkbox"/>
MPSRGR10	Replacement glass rods for MPSR stations (10 pack).	<input type="checkbox"/>
MPSR-LP	Double action cover for MPSR stations	<input type="checkbox"/>
27193-11	Pull Station Accessory, 1-gang Surface Box for 270, Red	<input type="checkbox"/>
27193-16	Pull Station Accessory, 1-gang Surface Mount Box, White	<input type="checkbox"/>



Hazardous Location Fire Alarm Manual Station

The MPSR1-D45WX-GE is an extremely rugged fire alarm station suitable for hazardous locations. The MPSR1-D45WX-GE is a single action station that can be converted to a double-action by adding a MPSR-LP.

MPSR1-D45WX-GE	Single-action, DPDT, Cat 45 Key reset, terminal connections	Data Sheet S85001-0588	<input type="checkbox"/>
----------------	---	------------------------	--------------------------

Fire Alarm
Control Panels

Intelligent
Addressable Devices

**Conventional
Initiating Devices**

Wall Strobes, Horns and Chimes p. 32

Wall Speakers and Speaker-strobes p. 34

Ceiling Speakers, Horns and Strobes p. 35

Weatherproof Signals p. 36

Hazardous Location Horns and Strobes p. 37

Audio Notification System p. 38

Notification Appliances

Genesis notification appliances are high-performance devices finely tuned to deliver maximum output in exchange for the lowest possible current draw. Covering the entire spectrum of life safety applications, these devices are durable, dependable, and virtually maintenance-free. And they support a wide range of mounting options that make them ideal for new construction and retrofit applications alike.

The E-FSA250 intelligent and E-FSC1004 conventional fire control panels come equipped with four notification appliance circuits that can be wired to provide four Class B NACs or two Class A NACs. The E-FSA64 comes with two Class B NACs. These may be configured for Class A operation with the optional SA-CLA Class A Module installed. The E-FSC502 comes with two Class B NACs that can be configured as one Class A NAC. The E-FSC302 has two Class B NACs.

Edwards NACs may be individually configured for continuous, temporal, synchronized, and coded output.

Edwards NACs are configurable to fully support the advanced signaling technology of Genesis notification appliances. These devices offer precision synchronization of strobes to UL 1971 standards. For Genesis devices, enabling this feature allows connected horns to be silenced while strobes on the same two-wire circuit continue to flash until the panel is reset.

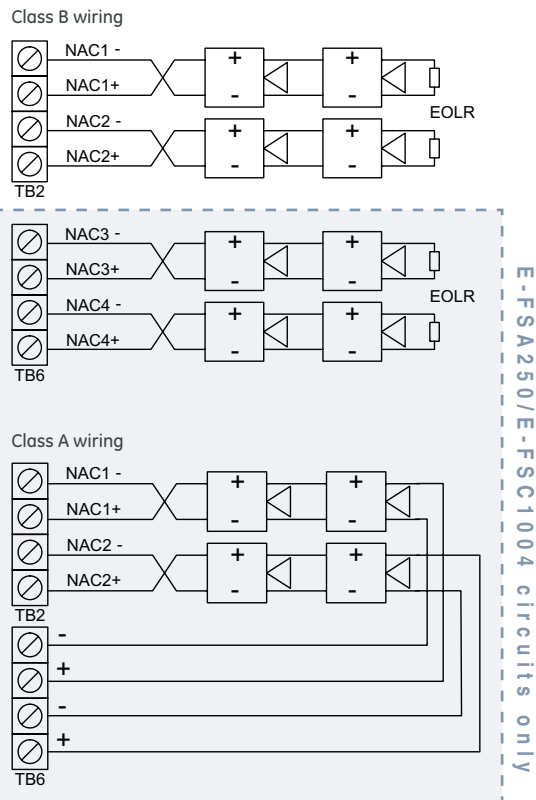

Genesis Series

Wall Strobes, Horns & Chimes



The Genesis line of signals are among the smallest, most compact audible-visible emergency signaling devices in the world. About the size of a deck of playing cards, these devices are designed to blend with any decor. They feature textured housings in architecturally neutral white or traditional fire red. An ingenious iconographic symbol indicates the purpose of the device. This universal symbol is code-compliant and is easily recognized by all building occupants regardless of what language they speak. Models with "FIRE" markings are also available.

Signals can be synchronized when connected to Edwards E-FSC and E-FSA fire panels, EBPS booster supplies, or with the use of EG1M(-RM) synch modules.

Genesis Wall Strobes

Genesis wall strobes offer 15 to 110 candela output, which is selectable with a conveniently-located switch on the side of the device. The candela output setting remains clearly visible even after final installation, yet it stays locked in place to prevent unauthorized tampering.

<input type="checkbox"/>	EG1-VM	Strobe, wall mt., 15-110 CD, 24VDC, white	Data Sheet S85001-0573
<input type="checkbox"/>	EG1R-VM	Strobe, wall mt., 15-110 CD, 24VDC, red	Data Sheet S85001-0573
<input type="checkbox"/>	EG1F-VM	Strobe, wall mt., 15-110 CD, Marked "Fire", 24VDC, white	Data Sheet S85001-0573
<input type="checkbox"/>	EG1RF-VM	Strobe, wall mt., 15-110 CD, Marked "Fire", 24VDC, red	Data Sheet S85001-0573

Genesis Horns and Horn-strobes

Genesis Horns and Horn-strobes reach output levels as high as 99 dB and features a unique multiple frequency tone that results in excellent wall penetration and an unmistakable warning of danger. Horns may be configured for either coded or non-coded signal circuits. They can also be set for low dB output with a jumper cut that reduces horn output by about 5 dB.

<input type="checkbox"/>	EG1-HDVM	Horn/Strobe, wall mt., 15-110 CD, 24VDC, white	Data Sheet S85001-0573
<input type="checkbox"/>	EG1R-HDVM	Horn/Strobe, wall mt., 15-110 CD, 24VDC, red	Data Sheet S85001-0573
<input type="checkbox"/>	EG1F-HDVM	Horn/Strobe, wall mt., 15-110 CD, Marked "Fire", 24VDC, white	Data Sheet S85001-0573
<input type="checkbox"/>	EG1RF-HDVM	Horn/Strobe, wall mt., 15-110 CD, Marked "Fire", 24VDC, red	Data Sheet S85001-0573
<input type="checkbox"/>	EG1-HD	Horn, temporal, 24VDC, white	Data Sheet S85001-0573
<input type="checkbox"/>	EG1R-HD	Horn, temporal, High/Low dB, 24VDC, red	Data Sheet S85001-0573
<input type="checkbox"/>	EG1-P	Horn, steady, 24VDC, white	Data Sheet S85001-0573
<input type="checkbox"/>	EG1R-P	Horn, steady, High/Low dB, 24VDC, red	Data Sheet S85001-0573
<input type="checkbox"/>	EG1F-HD	Horn, temporal, High/Low dB, Marked "Fire", 24VDC, White	Data Sheet S85001-0573
<input type="checkbox"/>	EG1RF-HD	Horn, temporal, High/Low dB, Marked "Fire", 24VDC, Red	Data Sheet S85001-0573
<input type="checkbox"/>	EG1F-P	Horn, steady, Marked "Fire", 24VDC, White	Data Sheet S85001-0573
<input type="checkbox"/>	EG1RF-P	Horn, steady, Marked "Fire", 24VDC, Red	Data Sheet S85001-0573

Genesis Chimes and Chime-strokes

Genesis chimes and chime-strokes produce a pleasing mellow tone. When steady (non-stroked) voltage is applied, the chime automatically pulses at 60 strokes per minute, or may be field-configured for temporal output. When installed with an EG1M Signal Master Module, the chime may also be field-configured for coded operation, which enables the chime output to match the rate that voltage is applied to the circuit. The chime's 79 dBA (peak) output level makes this device suitable for many applications. Chimes may be set for low dB output with a jumper cut that reduces sound output by about 5 dB.

EG1-CVM	Genesis Chime-Strobe (15, 30, 75, or 110 cd output, high or low dB), white	Data Sheet S85001-0574	<input type="checkbox"/>
EG1R-CVM	Genesis Chime-Strobe (15, 30, 75, or 110 cd output, high or low dB), red	Data Sheet S85001-0574	<input type="checkbox"/>
EG1-C	Genesis Chime (selectable high or low dB output), white	Data Sheet S85001-0574	<input type="checkbox"/>
EG1R-C	Genesis Chime (selectable high or low dB output), red	Data Sheet S85001-0574	<input type="checkbox"/>
EG1F-CVM	Chime/Strobe, Wall Mt., 15-95 CD, Marked "Fire", 24VDC, White	Data Sheet S85001-0574	<input type="checkbox"/>
EG1RF-CVM	Chime/Strobe, Wall Mt., 15-95 CD, Marked "Fire", 24VDC, Red	Data Sheet S5001-0574	<input type="checkbox"/>
EG1F-C	Chime, Wall Mt., Marked "Fire", 24VDC, White	Data Sheet S85001-0574	<input type="checkbox"/>
EG1RF-C	Chime, Wall Mt., Marked "Fire", 24VDC, Red	Data Sheet S85001-0574	<input type="checkbox"/>

Genesis Wall Mount Device Accessories



Optional trim plates available in red and white with or without "FIRE" marking



Housings with optional "FIRE" markings

EG1T-FIRE	Genesis Trim Plate (for 2-gang or 4" sq. boxes) with "FIRE" markings, white	Data Sheet S85001-0573	<input type="checkbox"/>
EG1RT-FIRE	Genesis Trim Plate (for 2-gang or 4" sq. boxes) with "FIRE" markings, red	Data Sheet S85001-0573	<input type="checkbox"/>
EG1T	Genesis Trim Plate (for 2-gang or 4" sq. boxes), white	Data Sheet S85001-0573	<input type="checkbox"/>
EG1RT	Genesis Trim Plate (for 2-gang or 4" sq. boxes), red	Data Sheet S85001-0573	<input type="checkbox"/>
EG1M	Genesis Piggy Back Synch Module	Data Sheet S85001-0573	<input type="checkbox"/>
EG1M-RM	Genesis Remote Mount Synch Module	Data Sheet S85001-0573	<input type="checkbox"/>

Genesis Series

Wall Speakers and Speaker-strobes

Genesis speakers include a DC blocking capacitor to allow electrical supervision of the audio distribution circuit. Models for 25 V_{RMS} and 70 V_{RMS} circuits are available. The mylar speaker with its sealed back construction provides extra durability and improved audibility. ¼ W to 2 W operation is selectable with a conveniently-located switch on the bottom of the device. They are compatible with standard 4-inch (10 cm) square electrical boxes and don't require extension rings or trim plates. No mounting screws are visible when the unit is installed, providing a clean, finished, unobtrusive appearance that blends with any decor.

Speaker-strobes feature 15, 30, 75 or 110 candela output, selectable with a conveniently-located switch on the bottom of the device. Strobes can be synchronized when connected to Edwards E-FSC and E-FSA fire panels, EBPS booster supplies, or EG1M-RM sync module

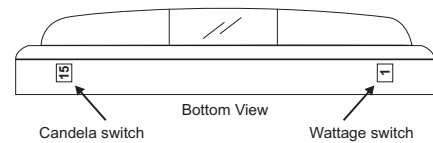

Candela and wattage settings remain clearly visible even after final installation.

#18 - #12 AWG terminals – ideal for long runs, existing wiring

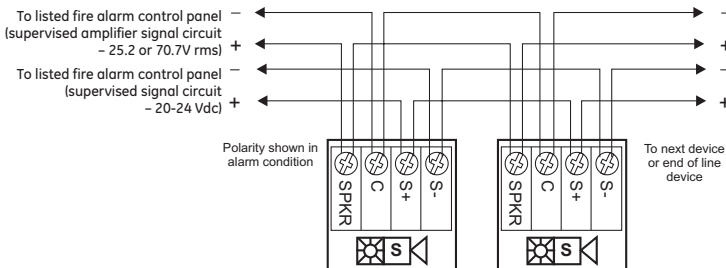

Genesis speakers are available with white or red housings and with or without FIRE markings.

Genesis Speakers and speaker-strobes Data Sheet S85001-0549

	White housing no "FIRE"	Red housing no "FIRE"	White housing with "FIRE"	Red housing with "FIRE"	
<input type="checkbox"/>	<input type="checkbox"/> EG4-S2	<input type="checkbox"/> EG4R-S2	<input type="checkbox"/> EG4F-S2	<input type="checkbox"/> EG4RF-S2	Multi-wattage 25 Volt Speaker
<input type="checkbox"/>	<input type="checkbox"/> EG4-S2VM	<input type="checkbox"/> EG4R-S2VM	<input type="checkbox"/> EG4F-S2VM	<input type="checkbox"/> EG4RF-S2VM	Multi-candela/wattage 25 Volt Speaker-strobe
<input type="checkbox"/>	<input type="checkbox"/> EG4-S7	<input type="checkbox"/> EG4R-S7	<input type="checkbox"/> EG4F-S7	<input type="checkbox"/> EG4RF-S7	Multi-wattage 70 Volt Speaker
<input type="checkbox"/>	<input type="checkbox"/> EG4-S7VM	<input type="checkbox"/> EG4R-S7VM	<input type="checkbox"/> EG4F-S7VM	<input type="checkbox"/> EG4RF-S7VM	Multi-candela/wattage 70 Volt Speaker-strobe

All speakers feature selectable ¼, ½, 1, or 2 watt operation. Multi-candela strobes feature 15, 30, 75, or 110 candela output.

Genesis Wall Speaker and Speaker Strobe Accessories

<input type="checkbox"/>	EG4RB	Speaker Surface box, red, indoor
<input type="checkbox"/>	EG4B	Speaker Surface box, white, indoor

Genesis EG4B Speaker Surface Box



Genesis Series

Ceiling Speakers, Horns, and Strobes

The Genesis line of multi-candela and multi-wattage ceiling signals feature all the hallmarks that have made Genesis products a big hit with designers, engineers, building owners, and installers everywhere. The Genesis exclusive FullLight technology, precision timing electronics, and low current draw bring the benefits of the popular Genesis wall-mount models to ceiling applications. Up to 30 percent slimmer than comparable signals on the market, they are compatible with standard 4-inch (10 cm) square electrical boxes and don't require extension rings or trim plates. No mounting screws are visible when the unit is installed, providing a clean, finished, unobtrusive appearance that blends with any decor. These signals are also listed for wall mount applications. Strobes can be synchronized when connected to Edwards E-FSC and E-FSA fire panels, EBPS booster supplies, and EG1M-RM remote synch module.



Select 15/30/75/95 and 95/115/150/177 candela output!

177

2

Select ¼, ½, 1, or 2 watt operation!

White Field configurable Speaker-Strobes may be ordered with or without "FIRE" marking. Red Speaker-Strobes come with "FIRE" marking.



White housing ↓ no "FIRE"	White housing ↓ with "FIRE"	Red housing ↓ with "FIRE"			
Strobes					
<input type="checkbox"/> EGC-VM	<input type="checkbox"/> EGCF-VM	<input type="checkbox"/> EGCFR-VM	Multi-cd Strobe	Data Sheet S85001-0557	<input type="checkbox"/>
<input type="checkbox"/> EGC-VMH	<input type="checkbox"/> EGCF-VMH		Multi High-cd Strobe	Data Sheet S85001-0557	<input type="checkbox"/>
Horn/strobes					
<input type="checkbox"/> EGC-HDVM	<input type="checkbox"/> EGCF-HDVM	<input type="checkbox"/> EGCFR-HDVM	Multi-cd Horn-Strobe	Data Sheet S85001-0559	<input type="checkbox"/>
<input type="checkbox"/> EGC-HDVMH	<input type="checkbox"/> EGCF-HDVMH		Multi High-cd Horn-Strobe	Data Sheet S85001-0559	<input type="checkbox"/>
Speakers and speaker/strobes					
<input type="checkbox"/> EGC-S2	<input type="checkbox"/> EGCF-S2		Multi-wattage 25 V Speaker	Data Sheet S85001-0558	<input type="checkbox"/>
<input type="checkbox"/> EGC-S7	<input type="checkbox"/> EGCF-S7	<input type="checkbox"/> EGCFR-S7	Multi-wattage 70 V Speaker	Data Sheet S85001-0558	<input type="checkbox"/>
<input type="checkbox"/> EGC-S2VM	<input type="checkbox"/> EGCF-S2VM		Multi-cd/wattage 25 V Spkr-strobe	Data Sheet S85001-0556	<input type="checkbox"/>
<input type="checkbox"/> EGC-S2VMH	<input type="checkbox"/> EGCF-S2VMH		Multi High-cd/wattage 25 V Spkr-strobe	Data Sheet S85001-0556	<input type="checkbox"/>
<input type="checkbox"/> EGC-S7VM	<input type="checkbox"/> EGCF-S7VM	<input type="checkbox"/> EGCFR-S7VM	Multi-cd/wattage 70 V Spkr-strobe	Data Sheet S85001-0556	<input type="checkbox"/>
<input type="checkbox"/> EGC-S7VMH	<input type="checkbox"/> EGCF-S7VMH		Multi High-cd/wattage 70 V Spkr-strobe	Data Sheet S85001-0556	<input type="checkbox"/>

All speakers feature selectable ¼, ½, 1, or 2 watt operation. All horns feature high or low dB output. Multi-Candela Strobes feature 15, 30, 75, or 95 candela output. Multi High-Candela Strobes feature 95, 115, 150, or 177 candela output.

Signal Master /Synchronization Module

The Signal Master is a simple-to-use accessory that adds enhanced features to Genesis strobes, speaker strobes and horn-strobes. It is a dual-purpose module that provides UL 1971 required precision synchronization for connected Genesis strobes, and independent control for connected Genesis horns over a single pair of wires. Two methods of horn control are available: traditional horn silence; or, normally-closed contact. Both methods may be used to silence horns without turning off strobes on the same circuit. Two models are available. The Genesis "piggyback" model doesn't require a separate electrical box. It simply snaps to the back of the first EG1 signal on the circuit. The remote mount model mounts in a North American 2½ inch (64 mm) deep one-gang box. Edwards panels and power boosters provide the same functionality as the Signal Master when Genesis Mode is enabled. Synchronization modules must be listed as compatible to the panels.



Snap-on (piggyback) model



Remote 1-gang mount model

EG1M	Genesis Signal Master – Snap-on (piggyback), 2 amp max.	Data Sheet S85001-0545	<input type="checkbox"/>
EG1M-RM	Genesis Signal Master – Remote 1-gang mount, 2 amp max.	Data Sheet S85001-0545	<input type="checkbox"/>

Note: EG1M can't be used with EG4 or EGC speaker strobes

Enhanced Signals

Weatherproof Signals

All Enhanced Integrity devices are UL 1971 listed for both wall and ceiling orientation. Enhanced Integrity strobes meet the latest UL1971 synchronization requirements when used with compatible Edwards panels or the EG1M-RM Signal Master. Integrity devices are shipped with wall mount style "FIRE" lens markings. Other lens markings are available.

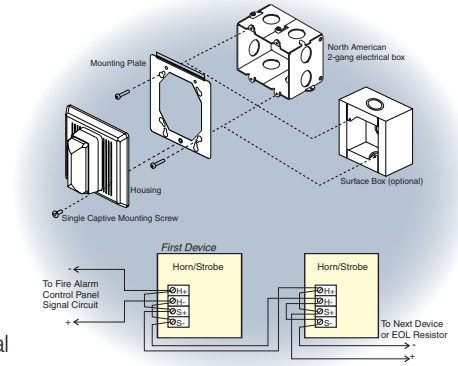

Weatherproof Horns and Horn-Strobes

During installation, the Horn is configured for steady or temporal tone signal. When temporal output is selected, all Horns on a common two-wire circuit are self-synchronized. Integrity Series Horns emit a low frequency "growling" tone that demands attention. Horns can be configured for either high output (98 dBA) or low output (94 dBA); and are listed for outdoor use. (Order weatherproof mounting box separately.)

<input type="checkbox"/>	2447TH-R	Temporal Horn, Red	Data Sheet S85001-0341
<input type="checkbox"/>	2452THS-15/75-R	Temporal Horn-Strobe, 15/75cd, Red	Data Sheet S85001-0341
<input type="checkbox"/>	2452THS-110-R	Temporal Horn-Strobe, 110cd, Red	Data Sheet S85001-0341

Important Note: 2459-WPB-R back box must be specified and ordered separately for weather-proof rating



Weatherproof Strobe

CS405 Series strobes are weatherproof devices specially designed for use with compatible life safety communication and control equipment to alert the hearing impaired of a life safety event. Strobes are available with 15/75 cd effective flash intensity. They are fully compatible with Genesis signals.

CS405 Series strobes exceed UL synchronization requirements (within 10 milliseconds other over a two-hour period) when used with a compatible synchronization source. The flash from 405 Series strobes can be noticed from almost any position in the room, corridor, or large open space. 405 Series strobes are UL 1971 listed with both wall and ceiling cd intensity ratings (see Specifications). This is useful in areas where the Authority Having Jurisdiction (AHJ) permits ceiling-mount strobes. 405 Series strobes are designed for 16 to 33 Vdc operation and must be connected to signal circuits that output a constant (not pulsed) voltage. A diode is used to allow full signal circuit supervision and polarized connections are made to terminals that accept up to #12 AWG (2.5mm²) wire. The strobe front plate is of steel construction finished with durable baked epoxy polyester powder-coat paint.

<input type="checkbox"/>	<input type="checkbox"/> CS405-7A-T (15/75 cd)	<input type="checkbox"/> CS405-8A-T (110 cd)	Strobe - Weatherproof (red)	Data Sheet S85001-0305
--------------------------	--	--	-----------------------------	------------------------

Important Note: 449 back box must be specified and ordered separately for weather-proof rating

Accessories

<input type="checkbox"/>	449	Weatherproof Notification Appliance Wall Box for CS405 strobes	Data Sheet S85001-0305
<input type="checkbox"/>	2459-WPB-R	Fire Alarm Signal Accessory, Water-Proof Box, Red, for 2452THS-110-R, 2452THS-15/75-R, and 2447TH	Data Sheet S85001-0341

Hazardous Location Horns & Strobes

Hazardous Location Strobes

- Class I, Division 1, Groups C and D;
- Class I, Division 2 Groups A, B, C, and D;
- Class II, Division 1, Groups E, F, and G;
- Class II, Division 2, Groups F and G;
- Class III, Division 1 and 2

116DEGEX-FJ hazardous location strobes are in-rush current limited life safety signaling appliances designed for installation in hazardous environments. Rigid specifications and state-of-the-art technology provide for high visual output and low maintenance. When pendant, wall or ceiling mounted, the 116DEGEX-FJ meets or exceeds the requirements of UL 1971 Signaling Appliance for the Hearing Impaired. Rated for 125 candela ceiling mount, 60 candela wall mount.

Note: Can be synchronized when connected to compatible Edwards fire panel or booster power supply, or with EG1M-RM synch module.



116DEGEX-FJ	Explosionproof Strobe, Diode Polarized	Data Sheet S85001-0586	<input type="checkbox"/>
<input type="checkbox"/> 116EX-B Wall Mount Elbow	<input type="checkbox"/> 116EX-C Ceiling/wall Module	<input type="checkbox"/> 116EX-P Pendant Module	<input type="checkbox"/>

Hazardous Location Horns

- Class I groups B, C and D locations
- Class III hazardous locations, for Divisions 1 and 2
- Class II groups E, F and G locations

888D and 889D hazardous location horns are diode-polarized, heavy duty, high decibel vibrating horns intended for use in life safety systems in hazardous (classified) indoor locations. These horns may be mounted to any solid surface using two bolts. Each unit is supplied with a sealing fitting for a 3/4 inch -14 National Pipe Taper (NPT) nipple, and wire leads for the electrical connection to the life safety system notification appliance circuit.

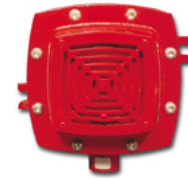

888D-N5	Fire Alarm Horn, Explosion-Proof, 120VAC	Data Sheet S85001-0397	<input type="checkbox"/>
889D-AW	Fire Alarm Horn, Explosion-Proof, 24VDC	Data Sheet S85001-0397	<input type="checkbox"/>

Audio Notification System

The ANS series of products from Edwards are high-performance audio notification systems that provide voice evacuation capability that meet the Emergency Voice Alarm requirements of NFPA 72 for UL listed fire alarm applications. ANS panels, which are available in 25, 50, or 100 Watt models, include an amplifier, tone generator, digital message repeater (DMR), and supervisory interface.

These self-contained systems offer robust field-configurable features and are supported by a wide range of accessory equipment that provides application flexibility and reliable performance for new and retrofit installations alike. Expander panels and modules extend the range of the ANS system to meet the needs of even the most demanding audio applications, while accessory equipment such as zone switchers and remote microphones offer the sophistication of high-end systems for a relatively low cost.

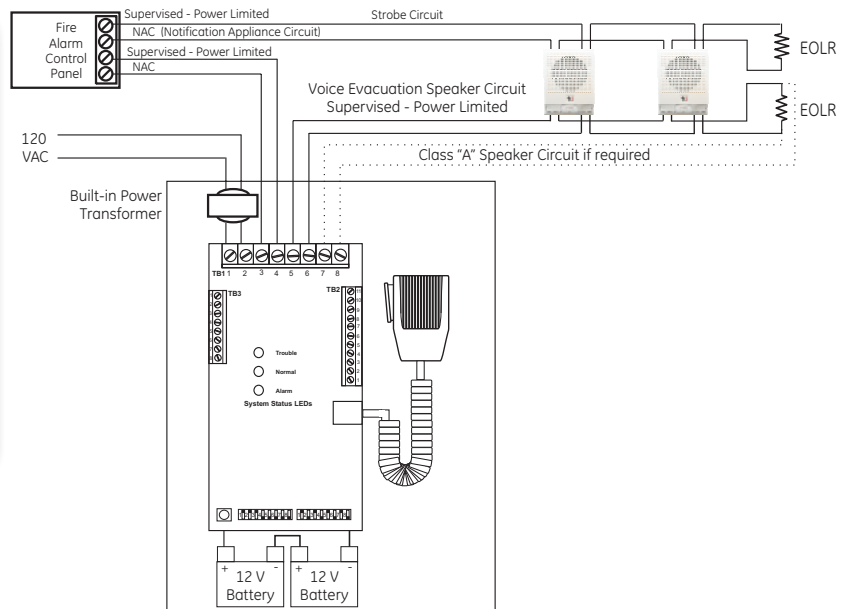

Audio Notification Panels

Panels include DMR, temporal pattern, standard message, microphone, power supply and battery charger.

<input type="checkbox"/>	<input type="checkbox"/> ANS25MDG (Gray cabinet)	<input type="checkbox"/> ANS25MDR (Red cabinet)	25 Watt Audio Notification Panel.	Data Sheet S85001-0587
<input type="checkbox"/>	<input type="checkbox"/> ANS50MDG (Gray cabinet)	<input type="checkbox"/> ANS50MDR (Red cabinet)	50 Watt Audio Notification Panel.	Data Sheet S85001-0587
<input type="checkbox"/>	<input type="checkbox"/> ANS100MDG (Gray cabinet)	<input type="checkbox"/> ANS100MDR (Red cabinet)	100 Watt Audio Notification Panel	Data Sheet S85001-0587

Audio Expander Panels

Panels include power supply and battery charger. DMR and microphone ordered separately.

<input type="checkbox"/>	<input type="checkbox"/> ANS25XG (Gray cabinet)	<input type="checkbox"/> ANS25XR (Red cabinet)	25 Watt Audio Expander Panel.	Data Sheet S85001-0587
<input type="checkbox"/>	<input type="checkbox"/> ANS50XG (Gray cabinet)	<input type="checkbox"/> ANS50XR (Red cabinet)	50 Watt Audio Expander Panel.	Data Sheet S85001-0587
<input type="checkbox"/>	<input type="checkbox"/> ANS100XG (Gray cabinet)	<input type="checkbox"/> ANS100XR (Red cabinet)	100 Watt Audio Expander Panel.	Data Sheet S85001-0587

Option Modules

<input type="checkbox"/>	<input type="checkbox"/> ANSZS4B (4 Class B)	<input type="checkbox"/> ANSZS2A (2 Class A)	Zone splitter.	Data Sheet S85001-0587
<input type="checkbox"/>	<input type="checkbox"/> ANSREMG (Gray cabinet)	<input type="checkbox"/> ANSREMR (Red cabinet)	Remote microphone.	Data Sheet S85001-0587
<input type="checkbox"/>	ANSREMSUP		Remote microphone supervisory card (1 required for up to 5 remote microphones).	Data Sheet S85001-0587
<input type="checkbox"/>	ANSBKUP		Backup amplifier switching module.	Data Sheet S85001-0587

Door Holders

Electromagnetic Door Holders

Edwards electromagnetic door holders keep doors open until signaled by the fire alarm system, a heat detector, a smoke detector, or an electrical switch. Door holders should be installed wherever doors may be effectively used to confine smoke and fire, or where the release of a self-closing door from a remote location is required. Fail-safe operation is an inherent feature of these door holders. If power fails, doors are released automatically, but may be opened or closed manually at any time. All units are free of moving parts, are self-contained, and require no maintenance. Door holders have a minimum holding force of 25 Lbf; 50 Lbf max.



<input type="checkbox"/> 1501-AQN5 (Single Door)	<input type="checkbox"/> 1502-AQN5 (Double Door)	Floor Mounted	Data Sheet S85001-0421	<input type="checkbox"/>
<input type="checkbox"/> 1504-AQN5 (Long Catch Plate)	<input type="checkbox"/> 1505-AQN5 (Short Catch Plate)	Flush Wall Mounted	Data Sheet S85001-0421	<input type="checkbox"/>
<input type="checkbox"/> 1508-AQN5 (Surface)	<input type="checkbox"/> 1505-AQN9 (Completely flush)	Wall Mounted	Data Sheet S85001-0421	<input type="checkbox"/>
<input type="checkbox"/> 1500-1 (1.5" Extension)	<input type="checkbox"/> 1500-2 (2.5" Extension)	Extension Rod	Data Sheet S85001-0421	<input type="checkbox"/>
<input type="checkbox"/> 1500-7 (5.25 to 7.5" Extension)	<input type="checkbox"/> 1500-12 (7.5 to 12" Extension)	Extension Rod	Data Sheet S85001-0421	<input type="checkbox"/>
<input type="checkbox"/> CS2595-5 (short)	<input type="checkbox"/> CS2598-5 (long)	Replacement Armature	Data Sheet S85001-0421	<input type="checkbox"/>

Relays

Four-Voltage SPDT/DPDT Control Relays

MR Series multi-voltage control relays are ideal for applications where local contacts are required for system status, remote contacts, or for control of electrical loads and general purpose switching. They are suitable for use with HVAC temperature control, fire alarm, security, energy management, and lighting control systems. Relays provide 10-Amp contacts, which may be operated by one of four input control voltages. Each relay position contains a red LED that indicates the relay coil is energized. Relays may be snapped apart from a standard four-module assembly and used independently.



MR101/C	Single SPDT relay (in metal enclosure)	Data Sheet S270062	<input type="checkbox"/>
MR201/C	Single DPDT relay (in metal enclosure)	Data Sheet S270062	<input type="checkbox"/>

Heavy Duty DPDT Power Relays

MR-199 heavy duty power relays are designed for control applications where 30-Amp DPDT contacts are required. Two models are available: a 115Vac coil and a 24Vdc coil, each of which may be mounted in a rugged steel enclosure.



MR199X13/C	Power Relay — 24 VDC (in metal enclosure)	Data Sheet S270065	<input type="checkbox"/>
MR199X14/C	Power Relay — 120 VDC (in metal enclosure)	Data Sheet S270065	<input type="checkbox"/>

Three-Voltage Encapsulated Control Relays

PAM1 relays provide 10-Amp Form C contacts. The relay may be energized by one of three input voltages: 24Vac, 24Vdc, or 115Vac. The PAM1 may be mounted with double-sided adhesive tape, a self-tapping screw, or loosely placed in a backbox.



PAM1	Encapsulated SPDT relay	Data Sheet S270066	<input type="checkbox"/>
------	-------------------------	--------------------	--------------------------

Hazardous Location Classifications

Edwards hazardous location devices provide reliable life safety protection and emergency signaling in areas where atmospheres could become harsh or explosive. All hazardous location devices are UL rated under the full range of classifications set out in the National Electrical Code.

The following classification definitions are an interpretive summary based on the 1996 edition of the National Electrical Code (NEC, NFPA 70). Refer to the latest editions of NFPA 497M, NFPA 70 and the UL Hazardous Location Equipment Directory for current and more detailed information. For more information on NEMA classifications, refer to NEMA Standards Publication No. 250.

Hazardous Location Classifications

Classes

Class I - Hazardous Gases. Class I locations are areas in which flammable gases or vapors are or may be present in the air in quantities sufficient to produce explosive or ignitable mixtures.

Typical Class I Hazardous Areas

- Spray painting and finishing areas
- Utility gas plants
- Petroleum refining production plants
- Petroleum dispensing locations
- Dry cleaning facilities
- Dip tanks containing combustibles or flammable liquids
- Plant facilities extracting solvents
- Inhalation anesthetics areas
- Process facilities manufacturing pyroxylin type plastics

Class II - Hazardous Dusts. Class II locations represent areas that are hazardous due to the presence of combustible dust.

Typical Class II Hazardous Areas

- Flour mills
- Feed mills
- Grain elevators and grain handling facilities
- Aluminum manufacturing and storage areas
- Magnesium manufacturing and storage areas
- Coal preparation and handling facilities
- Starch manufacturing and storage areas
- Confectionery plants
- Pulverizer sugar and cocoa manufacturing, and storage plants
- Spice grinding and storage plants

Class III - Hazardous Fibers. Class III locations have easily ignitable fibers or flyings present, but not likely to be suspended in air in quantities sufficient to produce ignitable mixtures in the atmosphere.

Typical Class III Hazardous Areas

- Textile mills
- Woodworking plants*
- Furniture manufacturers*
- Cotton gins
- Cotton seed milling plants
- Flax plants
- Carpet manufacturers

* Except if wood flour (dust), which is Class II Group G, is present

Divisions

The Location Classes are broken down by the NFPA into Divisions 1 and 2, defining different levels of risk. In general, the risk of there being a hazardous presence of flammable/combustible/ignitable materials is higher for Division 1 than for Division 2. The specifics differ between the three classes (I, II and III). Equipment suitable for Division 1 is also suitable for Division 2 locations.

Groups

Class I and II locations are divided by the NFPA into Group designations identifying specific gases, vapors and dusts by characteristic similarities that relate to specific equipment construction requirements. Class III locations are not divided into separate group designations.

Class I Groups

Group A. Atmospheres containing acetylene.

Group B. Atmospheres containing hydrogen, fuel and combustible process gases containing more than 30 percent hydrogen by volume, or gases or vapors of equivalent hazard such as butadiene, ethylene oxide, propylene oxide, and acrolein.

Group C. Atmospheres such as ethyl ether, ethylene, or other gases or vapors of equivalent hazard.

Group D. Atmospheres containing acetone, ammonia, benzene, butane, cyclopropane, ethanol, gasoline, hexane, methanol, methane, natural gas, naphtha (petroleum), propane, or gases or vapors of equivalent hazard.

Class II Groups

Group E. Atmospheres containing combustible metal dusts, including aluminum, magnesium, and their commercial alloys, or other combustible dusts whose particle size, abrasiveness and conductivity present similar hazards in the use of electrical equipment.

Group F. Atmospheres containing combustible carbonaceous dusts, including carbon black, charcoal, coal, or dusts that have been sensitized by other materials so that they present an explosion hazard.

Group G. Atmospheres containing combustible dusts not included in Group E or F, including flour, grain, wood, plastic, and chemicals.

Index

Intelligent Control Panels

E-FSA64	Intelligent Fire Alarm Control Panel, 64 Points	3
SA-TRIM1	Semi-Flush Mt., Trim Kit, E-FSA64	3
E-FSA250R	Intelligent Fire Alarm Control Panel, 254 Points	3
D16L-FA	Remote Annunciator, LED, 16-Zone, 2-LEDs per Zone	3
SA-TRIM2	Semi-Flush Mt., Trim Kit, E-FSA250	3

Option Cards

XAL127	SLC Loop Expansion Module	4
SA-CLA	E-FSA64 Class A adapter module	4
SA-ETH	Ethernet Port	5
SA-232	Serial Port (RS-232)	5
260097	Cable SA-232 to PC,DB9 to wire leads	5
SA-DACT	Dual Line Dialer/Modem	5

Remote Annunciation

E-RLCD	LCD text annunciator without common controls.	6
RLCD-R	LCD text annunciator without common controls. Red.	6
E-RLCD-C	LCD text annunciator with common controls.	6
RLCD-CR	LCD text annunciator with common controls. Red.	6
E-RLED-C	16-pair LED zone annunciator with common controls.	6
RLED-CR	16-pair LED zone annunciator with common controls. Red.	6
RLED24R	24-pair LED zone expander with cable and zone card. Red.	6
RKEY	Remote key switch	7
RA-LED16ZC	Zone card insert for RLED-C, RLED-CR, and RLED-CF.	7
RA-LED24ZC	Zone card insert for RLED24, RLED24R.	7
27193-16	Surface Mount Box - Indoor, white, 1-gang	7
7300073	24-inch expander cable assembly	7
7120313-01	12-inch expander cable (cable only).	7
7120313-02	24-inch expander cable (cable only).	7
RA-ENC1	One-position enclosure for Remote Annunciator.	7
RA-ENC2	Two-position enclosure for Remote Annunciator and Remote Expander.	7
RA-ENC2	Three-position enclosure for Remote Annunciator and Remote Expander.	7
LSRA-SB	Surface Mount Box	7
GCI	Graphic Annunciator Driver	7

Conventional Panels & Accessories

E-FSC302	Conventional Fire Alarm Control Panel – 3 Class B IDCs	8
E-FSC502	Conventional Fire Alarm Control Panel – 5 Class B IDCs	8
E-FSC1004	Conventional Fire Alarm Control Panel – 10 Class B IDCs	8
F-TRIM35R	Semi-flush trim ring for RD and E-FSC502RD	8
F-TRIM10R	Semi-flush trim ring for E-FSC1004RD	8
EOL3.6-1.1	Required UL listed End of Line Resistors	8
F-DACT	Upload/download digital Communicator/modem/LCD module	9
CTM	City Tie Module	9
RPM	Reverse Polarity Module	9
FSRSI	Remote System Indicator	9
FSRZI-A	Remote Zone Indicator – Includes red LEDs for five IDCs.	9
FSRZI-SA	Remote Zone Indicator – Includes LEDs for five IDCs	9
FSRA10	Single Unit 10 zone remote annunciator for E-FSC1004R	9
FSRA10C	Single Unit 10 zone remote annunciator for E-FSC1004R, with common controls	9
FSUIM	Graphic Driver/Interface	9
FSRRM24	Remote Relay Module	9
FSRRM-S11	11" Mounting track. Holds up to 4 FSRRM24s.	9
FSAT2	Annunciator Trim Plate, 2 gang, White.	9
FSAT3	Annunciator Trim Plate, 3 gang, White.	9
MFC-A	Multi-function Cabinet, red.	9

Power Supplies

EBPS6A	6.5 Amp Booster Power Supply	10
EBPS10A	10 Amp Booster Power Supply	10
12VxA	12 Volt Batteries	10
BC-1R - Red	Battery Cabinet	10

System Accessories

F-DACT	Upload/download digital fire alarm (mounts in control panel)	11
CTM	City Tie Module	11
RPM	Reverse Polarity Module	11
PT-1S	Serial Printer	11

Intelligent Detectors and Bases

E-PD	Intelligent/Addressable Photoelectric Smoke Detector	14
E-PHD	Intelligent/Addressable Photoelectric Smoke/Heat Detector	14
E-HD	Intelligent/Addressable Heat Detector	14
B4U	Standard Base	15
IB4U	Isolator Detector Base	15
RB4U	Relay Detector Base	15
SB4U	Audible (Sounder) Detector Base	15
AB4G-SB	Surface Box for Audible Base	15
R-LED	Remote alarm LED. Use with standard base only.	15
211-10PKG	Replaceable smoke det. optical chamber	15
E-PDD	Intelligent Addressable SuperDuct Detector	16
SD-Txx	Sampling Tubes for SuperDuct Detector	16
SD-TRK4	Remote Test Stations for SuperDuct Detector	16
SD-MAG	Test magnet kit for SuperDuct Detector	16
SD-VTK	Air velocity test kit, stoppers only for SuperDuct Detector	16
SD-PH	Protective Housing	16
E-278	Double Action Fire Pull Station, Addressable	17
276B-RSB	Surface Mount Box, Red — for GSA-M278 series	17
276-GLR	20 Break-rods — for GSA-M278 series	17
E-270	Single Action Fire Pull Station, Addressable	17
270-GLR	Glass Replacement Rods for 270/FX-270 Series, 20 Count	17
P-027193	Cast Mounting Box, 270/FX-270 Series	17
P-039250	Steel Mounting Box, 270/FX-270 Series	17

Intelligent Modules

E-IDC1B	Single Input Mini Module (one-gang standard mount)	18
E-IDC2B	Dual Input Module (4x4 or two-gang standard mount)	18
E-2WIRE	Class A-B Two-Wire Module (4 x 4 or two-gang standard mount)	19
E-IDCWS	Dual Input Waterflow, Supervisory Module	19
E-ISO	SLC (Signalling Line Circuit) Fault Isolator Module	19
E-NAC	Intelligent Notification Appliance (NAC) module	20
E-RLY	Intelligent Addressable Contact Relay Module	20
MFC-A	Multi-function Cabinet	20
27193-11	Surface Mount Box - Red, One-gang	20
27193-16	Surface Mount Box - White, One-gang	20
27193-21	Surface Mount Box - Red, Two-gang	20
27193-26	Surface Mount Box - White, Two-gang	20
235196P	Bi-polar Transient Protector	20
EOL-4.7	EOL Resistor 4.7K, UL Listed	20
EOL-47	EOL Resistor, 47K, 1/2 watt, UL Listed	20
EOL-15	EOL Resistor, 15K, 1/2 watt, UL Listed	20

continued...

Index

Conventional Smoke Detectors and Bases

500 Series	Photoelectric 2-Wire Detector with options	21
700 Series	Two and Four-Wire Self-Diagnostic Smoke Detectors	22
TS7 Series	Two-Wire Detectors, 12/24VDC with options	22
204-12/24V	12/24V, end of line power supervision relay for 4-wire applications	22
211-10PKG	Replaceable smoke detector optical chamber	22
SM-200	Smoke! in a Can®	22
700 Series	2-Wire Fast Response Detectors with options	22
701U	6" Mounting Base for 711U and 711UT, 3 Terminals	22
702U	6" Universal Mounting Base, 700 Series, 6 Terminals	22

Beam Detectors

EC-50R	Beam Smoke Detector	23
EC-100R	Beam Smoke Detector	23
EC-LLT	Ground Level Test Station	23

Heat Detectors

280 Series	Heat Detectors	24
CR Series	Metal Heat Detectors	24
302 Series	Hazardous Location rate compensated heat detectors	25

Duct Detectors

SD-2W	Conventional 2-wire Duct Detector	26
SD-4WJ	Conventional 4-wire Duct Detector Controller with sensor	26

CO Detectors

250-CO	SafeAir carbon monoxide detector, alarm & trouble relays, sounder	27
250-COPLT	Adaptor plate for 250-CO	27

Manual Stations

270-SPO	Single-action pull station, single pole	28
270-DPO	Single action pull station, double pole	28
270-GLR	Glass rods for 270 Series manual stations	28
276B Series	Single-action pull station, single pole	28
278B Series	Double-action pull station	28
MPSR Series	Harsh Environment Manual Stations	29
MPSR1-D45WX	Hazardous Location Fire Alarm Station	29

Strobes, Horns

EG1-VM	Strobe, wall mt., 15-110 CD, 24VDC, white	32
EG1R-VM	Strobe, wall mt., 15-110 CD, 24VDC, red	32
EG1F-VM	Strobe, wall mt., 15-110 CD, Marked "Fire", 24VDC, white	32
EG1RF-VM	Strobe, wall mt., 15-110 CD, Marked "Fire", 24VDC, red	32
EG1-HDVM	Horn/Strobe, wall mt., 15-110 CD, 24VDC, white	32
EG1R-HDVM	Horn/Strobe, wall mt., 15-110 CD, 24VDC, red	32
EG1F-HDVM	Horn/Strobe, wall mt., 15-110 CD, Marked "Fire", 24VDC, white	32
EG1RF-HDVM	Horn/Strobe, wall mt., 15-110 CD, Marked "Fire", 24VDC, red	32
EG1-HD	Horn, temporal, 24VDC, white	32
EG1R-HD	Horn, temporal, High/Low dB, 24VDC, red	32
EG1-P	Horn, temporal, 24VDC, white	32
EG1R-P	Horn, temporal, High/Low dB, 24VDC, red	32
EG1F-HD	Horn, Temporal, High/Low dB, Marked "Fire", 24VDC, White	32
EG1RF-HD	Horn, Temporal, High/Low dB, Marked "Fire", 24VDC, Red	32
EG1F-P	Horn, Temporal, Marked "Fire", 24VDC, White	32
EG1RF-P	Horn, Temporal, Marked "Fire", 24VDC, Red	32

Chimes

EG1-CVM	Genesis Chime-Strobe (multi-cd output, high or low dB), white	33
EG1R-CVM	Genesis Chime-Strobe (multi-cd output, high or low dB), red	33
EG1-C	Genesis Chime (selectable high or low dB output), white	33
EG1R-C	Genesis Chime (selectable high or low dB output), red	33
EG1F-CVM	Chime/Strobe, Wall Mt., 15-95 CD, Marked "Fire", 24VDC, White	33
EG1RF-CVM	Chime/Strobe, Wall Mt., 15-95 CD, Marked "Fire", 24VDC, Red	33
EG1F-C	Chime, Wall Mt., Marked "Fire", 24VDC, White	33
EG1RF-C	Chime, Wall Mt., Marked "Fire", 24VDC, Red	33

Trim Plates

EG1T-FIRE	Genesis Trim Plate with "FIRE" markings, white	33
EG1RT-FIRE	Genesis Trim Plate with "FIRE" markings, red	33
EG1T	Genesis Trim Plate (for 2-gang or 4" sq. boxes), white	33
EG1RT	Genesis Trim Plate (for 2-gang or 4" sq. boxes), red	33

Speakers

EG4-S2	Multi-wattage 25 Volt Speaker	34
EG4-S2VM	Multi-candela/wattage 25 Volt Speaker-strobe	34
EG4-S7	Multi-candela/wattage 70 Volt Speaker-strobe	34
EG4-S7VM	Multi-candela/wattage 70 Volt Speaker-strobe	34
EG4RB	Speaker Surface box, red, indoor	34
EGC-VM	Multi-candela Ceiling Strobe	35
EGC-VMH	Multi High-candela Strobe	35
EGC-HDVM	Multi-candela Ceiling Horn/Strobe	35
EGC-Sx	Multi-wattage Ceiling Speaker	35
EGC-Sxxx	Multi-wattage Ceiling Speaker/Strobe	35
EG4B	Speaker Surface box, white, indoor	34
EG1M	Genesis Piggyback Synch Module	35
EG1M-RM	Genesis Remote Piggyback Synch Module	35

Weatherproof Signals

449	Weatherproof Notification Appliance Wall Box for CS405 strobes	36
2447TH	Temporal Horn	36
2452THS	Temporal Horn/Strobe	36
CS405	Weatherproof Strobe	36
2459-WPB-R	Fire Alarm Signal Accessory, Water-Proof Box, Red,	36

Hazardous Location Signals

116DEGEX-FJ	Explosionproof Strobe, Diode Polarized	37
888D-N5	Fire Alarm Horn, Explosion-Proof, 120VAC	37
889D-AW	Fire Alarm Horn, Explosion-Proof, 24VDC	37

Audio Notification

ANSxxMDG	Audio Notification Panels	38
ANSxxXG	Audio Expander Panels	38

Doorholders

1501-AQN5	Single Door, Floor Mounted	39
1502-AQN5	Double Door, Floor Mounted	39
1504-AQN5	Long Catch Plate, Flush Wall Mounted	39
1505-AQN5	Short Catch Plate, Flush Wall Mounted	39
1508-AQN5	Surface, Wall Mounted	39
CS2595-5	Short Replacement Armature	39
CS2598-5	Long Replacement Armature	39

Relays

MR101/C	Single SPDT relay (in metal enclosure)	39
MR201/C	Single DPDT relay (in metal enclosure)	39
MR199X13/C	Power Relay — 24 VDC (in metal enclosure)	39
MR199X14/C	Power Relay — 120 VDC (in metal enclosure)	39
PAM1	Encapsulated SPDT relay	39



Contact us...

Phone: 1-800-336-4206

Web: www.edwardssignaling.com

Edwards Signaling is
an **EDWARDS** brand.

3 Farm Glen Boulevard
Farmington, CT 06032

In Canada, contact Chubb Edwards...

Email: inquiries@chubbedwards.com

Web: www.chubbedwards.com

© 2013 UTC Fire & Security Americas Corporation, Inc. All rights reserved. Specifications subject to change without notice. Edwards is part of UTC Climate, Controls & Security, a unit of United Technologies Corporation.

Innovation... Invention... Ingenuity...

Throughout its entire 140 year history as an industry pioneer, these have always been the hallmarks of Edwards. Today, Edwards Signaling products and systems perform day-in and day-out in the toughest, most critical commercial and industrial applications throughout the world. From the bells that have reliably announced the opening and closing of the New York Stock Exchange every trading day since 1902, to innovative hazardous location signaling and fire alarm systems in petrochemical plants, Edwards Signaling is there for its customers.

When it comes to selecting Fire Alarm, Audible & Visual Signaling, Mass Notification and Voice Evacuation Systems, Machine Safeguarding and Video Security products, Edwards Signaling is a smart choice.



Alert



Warn



Communicate



Protect