



## CONFIGURED FLOOR LOADED ENCLOSED RACK SERIES

18U-27U-42U

FULLY ASSEMBLED RACK SYSTEMS FOR AUDIO, VISUAL OR NETWORKING EQUIPMENT. DESIGNED WITH HEAVY-GAUGE STEEL AND MULTIPLE FEATURES SUCH AS PRE-INSTALLED COOLING FANS, CASTERS, ADJUSTABLE FEET AND REMOVABLE SIDE PANELS.

### SPECIFICATIONS:

- Fully welded steel construction
- Weight capacity up to a 1,322 lb., depending on model
- Includes removable locking side panels
- 2 top-mounted DC UL Listed fans
- Includes locking, reversible and tinted glass door and locking rear access panel
- 4 pre-installed swivel casters (front casters lock) and leveling feet
- Each rack includes pre-installed shelves and blank panels

For more information please call 1-833-574-9124  
or email [AVARRO@adiglobal.com](mailto:AVARRO@adiglobal.com)

To learn more about AVARRO products visit  
[avarro.adiglobaldistribution.us](http://avarro.adiglobaldistribution.us)



**RK-ER42U****RK-ER42U (42 Unit Space)**

- Max Weight Capacity: 1,322lbs
- Dimensions of rack:  
23.63" x 23.63" x 77.51"
- Box Dimensions:  
25.5" x 25.75" x 86.89"
- Includes 7-2U vented shelves
- 9-2U blanks
- 2-5U vented shelves
- UPC: 840049305700

**RK-ER27U****RK-ER27U (27 Unit Space)**

- Max Weight Capacity: 900lbs
- Dimensions of rack:  
23.63" x 23.63" x 51.26"
- Box Dimensions:  
25.5" x 25.75" x 61"
- Includes 5-2U vented shelves  
and blanks
- UPC: 840049305694

**RK-ER18U****RK-ER18U (18 Unit Space)**

- Max Weight Capacity: 600lbs
- Dimensions of rack:  
23.63" x 23.63" x 35.51"
- Box Dimensions:  
25.5" x 25.75" x 45"
- Includes 3-2U vented shelves  
and blanks
- UPC: 840049305687

For more information please call 1-833-574-9124  
or email [AVARRO@adiglobal.com](mailto:AVARRO@adiglobal.com)

To learn more about AVARRO products visit  
[avarro.adiglobaldistribution.us](http://avarro.adiglobaldistribution.us)

## Expanded View and Parts

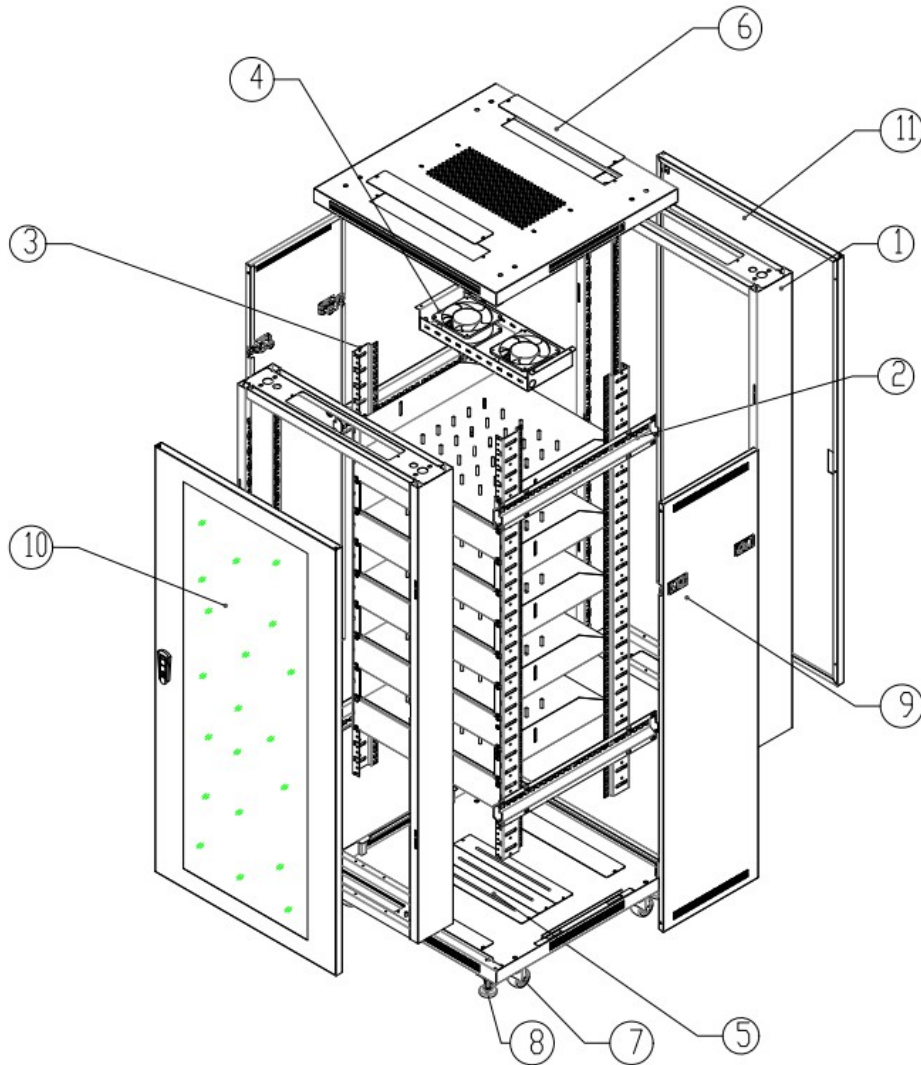

- 1 Frame
- 2 Mounting Bracket
- 3 Mounting Rail
- 4 UL Listed 2-Fan Tray
- 5 & 6 Cable Management Covers
- 7 Heavy Duty Casters (front casters lock)
- 8 Adjustable Feet
- 9 Removable Side Panels
- 10 Front, Tinted Glass Door  
(Option to reverse door)
- 11 Back Door (Option to reverse door)

For more information please call 1-833-574-9124  
or email [AVARRO@adiglobal.com](mailto:AVARRO@adiglobal.com)

To learn more about AVARRO products visit  
[avarro.adiglobaldistribution.us](http://avarro.adiglobaldistribution.us)

### Dimensions

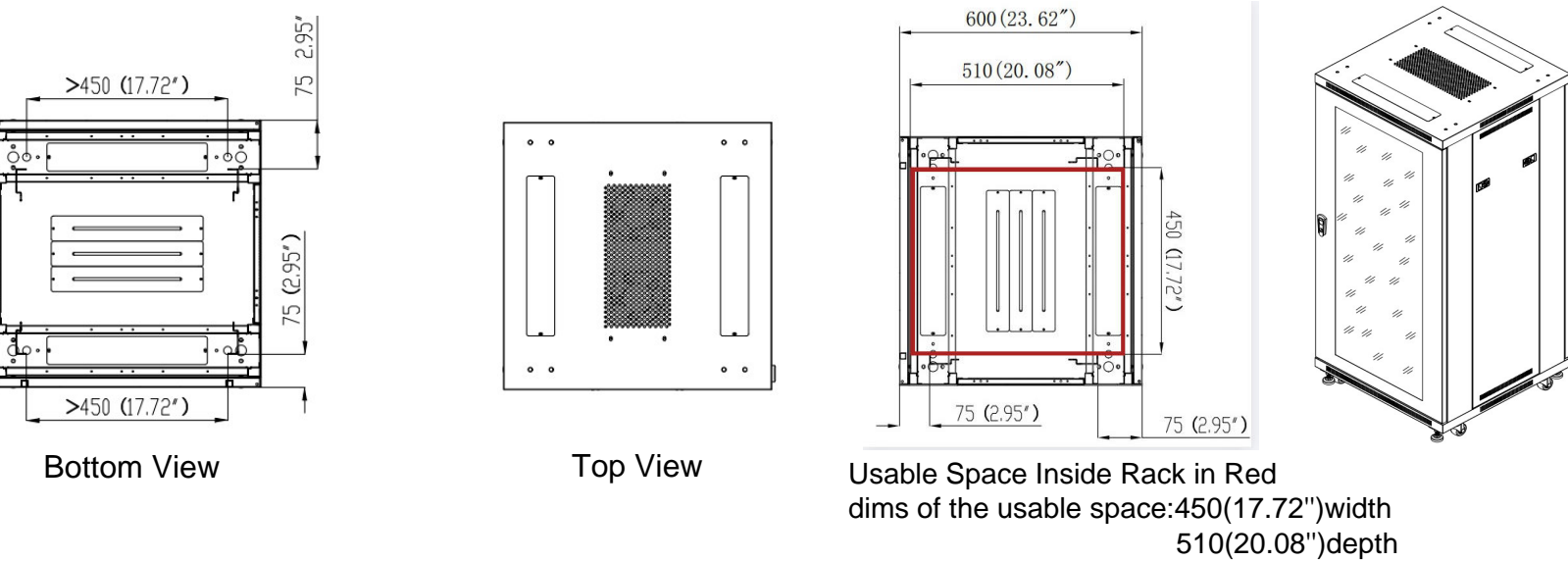
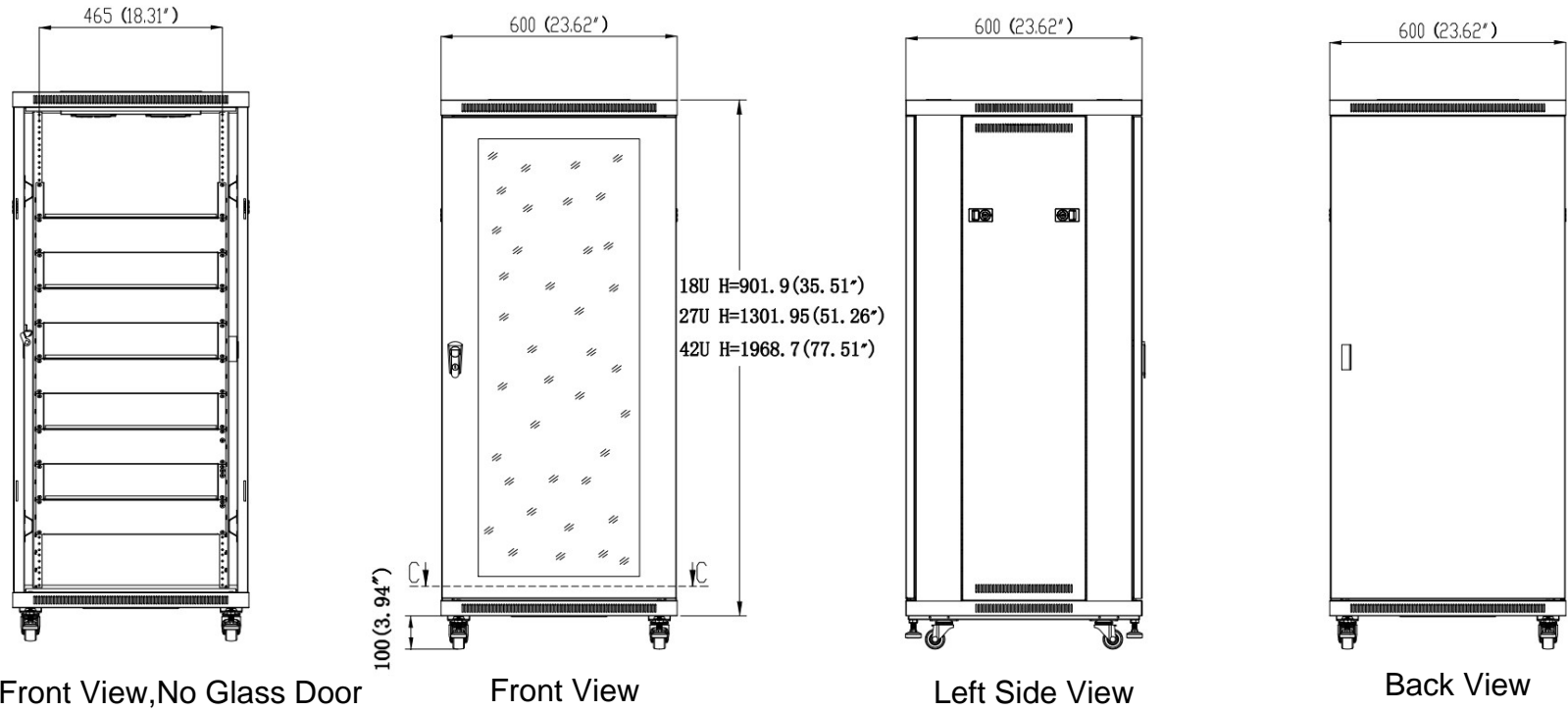

For more information please call 1-833-574-9124  
 or email AVARRO@adiglobal.com

To learn more about AVARRO products visit  
[avarro.adiglobaldistribution.us](http://avarro.adiglobaldistribution.us)