



Chief sets the industry standard with RPA® and RPA Elite® projector mounts with exclusive features that save time on installations. Industry-first features like MicroZone™ micro-adjustments provide perfect projector registration, while easy lamp and filter access make maintaining projectors fast.

milestone.com

CEILING MOUNTS & LIFTS

Chief's full line of projector mounts, lifts and accessories are backed by proven technologies and industry-leading customer service. Our exclusive features save time, setting the industry standard for projector mount solutions.

MOUNTFINDER

DON'T FORGET! Custom interfaces are also available for most projectors. Visit milestone.com and select your projector model in our MountFinder app for a list of compatible options.



RPAU

RPA ELITE FEATURES



Microzone™ Adjustments make projector registration fast and precise (including flush-mount installations).



Centris® Technology enables effortless fingertip positioning. Self-adjusts to support different projector weights.



Q-Lock™ quick release provides quick connect/disconnect of the projector for service and enhanced security with an integrated key and lock system.

ORDERING OPTIONS



Available in black, silver & white finishes.



Elite Projector Mount
RPMA

Mini Elite Projector Mount
RSMA

RPA Projector Mount
RPA

Mini RPA Projector Mount
RSA



Heavy Duty Projector Mount
VCM

Automated Projector Lift
SL236

Automated Projector Lift
SL220

Automated Projector Lift
SL151

SPECIFICATIONS

Model	Roll, Pitch, Yaw	MicroZone Adjustment	Weight Capacity	Max Projector Width	Required Accessories	Color
RSA*	±3°, ±20°, 360°		25 lbs (11.3 kg)	—	—	B S W
RSMA*	±3°, ±15°, 360°	•	25 lbs (11.3 kg)	—	—	B S W
RPA*	±4°, ±25°, 360°		50 lbs (22.7 kg)	—	—	B S W
RPMA*	±3°, ±20°, 360°	•	50 lbs (22.7 kg)	—	—	B S W
VCM*	±3°, ±20°, 360°		250 lbs (113.3 kg)	—	—	B
SL220	Varies		30 lbs (13.6 kg)	16.5" (419 mm)	RPM, RSM RPA or RSA	W
SL151	±2°, ±20°, ±5°		35 lbs (15.9 kg)	18" (457 mm)	SSBUW*	W
SL236	±2°, ±15°, ±10°		35 lbs (15.9 kg)	25" (635 mm)	SSBUW*	W

*Can be ordered in custom or universal. Silver & white finishes only available in universal option.

SUSPENDED CEILING SYSTEM

Chief's SYSAU Suspended Ceiling Projector System is designed to cut installation time by one-third. The new system also solves problems like inconsistent ceiling grid systems, adjustment and cumbersome installation processes with a host of innovative, tool-free features.

STANDARD SYSTEM FEATURES

- Adjustable ceiling plate allows placement above or below tile and accommodates inconsistent T-grids
- Compatible with 2' x 2', 2' x 4', 600 x 600 mm and 625 x 625 mm ceiling grids
- Detachable electric plate for pre-wiring
- Tool-Free Microzone™ adjustment with a positive drive system eliminates the need for set screws
- Centris™ Technology enables effortless fingertip positioning with new tool-free lock down
- Adjustable 0-12" (0-305 mm) column with dual inlay channels
- Improved universal interface for easier lock/unlock at projector connection
- Integrated key and lock system
- Quick-disconnect from interface to projector and interface to mount while maintaining registration
- System comes out of box in the order needed with mount and column preassembled
- Single SKU ordering with less packaging to recycle
- Black and white finish options





STORAGE SYSTEM FEATURES

- Plenum-rated enclosure is scalable to fit AV equipment
- Shift enclosure along tile bridge to avoid plenum interferences
- Removable covers enable side access in shallow plenum spaces and full access from above
- Six trade size conduit knockouts in 0.5", 1", 1.5" (12, 25, 38 mm)
- Flexible conduit knockouts allow high voltage conduit to pass through plenum box when the power is facing into the room below

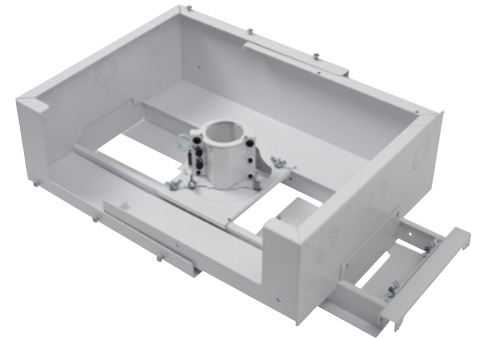

SURGEX® POWERED SYSTEM FEATURES

- Patented multi-stage protection includes industrial-grade surge protection and EMI/RFI noise filtration
- Improves the reliability and functionality of equipment by safeguarding from high energy transients, lightning strikes and electronic noise events that can cause gear degradation and downtime
- Features non-volatile spike protection with LED power indicator
- Non-current limiting design passes full power on a regular circuit; redundant protection circuits





SUSPENDED CEILING SYSTEM

ORDERING OPTIONS



**Suspended Ceiling
Projector System**
SYSAUB/SYSAUW

STANDARD SYSTEM

- Suspended ceiling kit
- RPT projector mount with adjustable column
- Universal interface
- Finishing ring



**Suspended Ceiling Projector
System with Storage**
SYS474UB/SYS474UW

STORAGE SYSTEM

- All components of the standard system
- Expandable, above-tile plenum enclosure

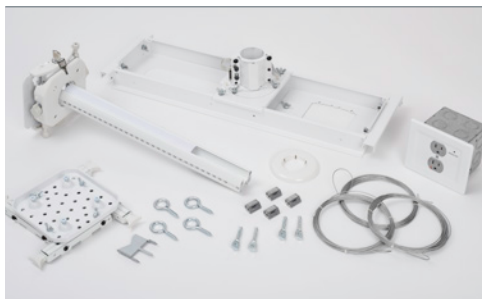

**Suspended Ceiling Projector
System with Filter & Surge**
SYSAUBP2/SYSAUWP2

POWERED SYSTEM

- All components of the standard system
- SurgeX® 2-gang filter and surge receptacle



SPECIFICATIONS

SYSAU	Weight Capacity	Overall Dimensions (HxWxD)	Projector Travel from Ceiling	color
	35 lbs (15.9 kg)	19.82 x 24.94 x 7.25" (504 x 634 x 184 mm)	3.14 - 14.74" (80 x 374 mm) in 0.5" (13 mm) increments	

Mount*	Dimensions (HxWxD)	Roll, Pitch, Yaw
	1.78 x 7 x 6.95" (45 x 178 x 177 mm)	±3°, ±10°, ±10°

*Dimensions for mount without column or interface

Ceiling Plate	Dimensions (HxWxD)	Height Adjust	Column Rotation	Column Shift
	4.6 x 24.94 x 7.25" (117 x 634 x 184 mm)	1" (26 mm)	360°	9.22" (234 mm)

Plenum Enclosure	Weight Capacity	Expanded Dimensions (HxWxD)	Collapsed Length (W)	Max Equipment Size
	35 lbs (15.9 kg)	5.38 x 22 x 13" (137 x 559 x 330 mm)	12" (305 mm)	5 x 17 x 12.5" (127 x 432 x 317 mm)

SurgeX® Receptacle	<ul style="list-style-type: none">• Filter reduces common and differential mode noise by up to 40 dB• Rated for 15 amps• 1875 watt maximum• Ferrite toroid based EMI filter• Withstand rating of 250 VAC continuous without damage or loss of protection
--------------------	--



SHORT THROW PROJECTOR MOUNTS



WM230AUS
SHORT THROW MOUNT

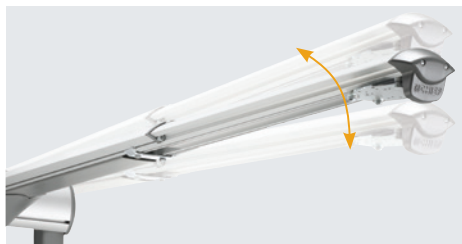
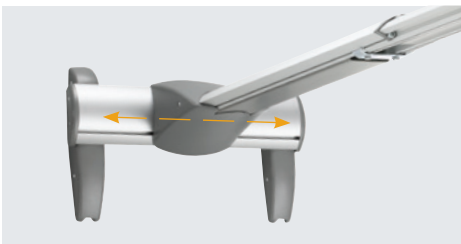

WM SERIES FEATURES

- Dual stud design provides up to 13" (330 mm) of lateral shift for quick alignment
- Industry-first micro height and leveling adjustment of $\pm 3^\circ$
- Telescoping extension and infinite projector placement make it easy to achieve a picture perfect installation
- Kits include short throw arm and RSMAUS Universal Mini Elite projector mount
- Includes hardware for wood stud, steel stud and concrete wall construction



**Short Throw
Wall Mount**
WP2 Series

**Micro-adjust Short Throw Wall
Mounts**
WM1 Series

**Micro-adjust Short Throw Wall
Mounts**
WM2 Series

SPECIFICATIONS

Model	Extension	Leveling	Lateral Shift	Weight Capacity	Color
WP21US Dual Wall Plate Mount	2 - 24" (50 - 600 mm)	+4°/-0°	1.75" (44 mm)	25 lbs (11.3 kg)	
WP22US Dual Wall Plate Mount	24 - 40" (610 - 1020 mm)	+4°/-0°	1.75" (44 mm)	25 lbs (11.3 kg)	
WP23US Dual Wall Plate Mount	40 - 56" (1020 - 1420 mm)	+4°/-0°	1.75" (44 mm)	25 lbs (11.3 kg)	
WM110AUS Single Wall Plate Mount	0 - 18" (0 - 457 mm)	±3°	-	25 lbs (11.3 kg)	
WM120AUS Single Wall Plate Mount	18 - 30" (457 - 762 mm)	±3°	-	25 lbs (11.3 kg)	
WM130AUS Single Wall Plate Mount	30 - 54" (762 - 1372 mm)	±3°	-	25 lbs (11.3 kg)	
WM210AUS Dual Wall Plate Mount	0 - 18" (0 - 457 mm)	±3°	13" (330 mm)	25 lbs (11.3 kg)	
WM220AUS Dual Wall Plate Mount	18 - 30" (457 - 762 mm)	±3°	13" (330 mm)	25 lbs (11.3 kg)	
WM230AUS Dual Wall Plate Mount	30 - 54" (762 - 1372 mm)	±3°	13" (330 mm)	25 lbs (11.3 kg)	
WM240AUS Dual Wall Plate Mount	54 - 65" (1372 - 1651 mm)	±3°	10" (254 mm)	25 lbs (11.3 kg)	

WHITEBOARD MOUNTS

The WBM3E installs directly to the wall over pre-existing dry erase boards or chalkboards without causing damage, providing the flexibility needed for classroom environments.



WBM3E
TELESCOPING WHITEBOARD WALL MOUNT

WBM3E FEATURES

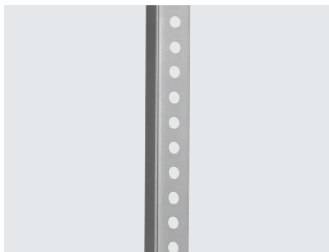

Uprights include 1" (25 mm) increments of macro height adjust, with an additional 1.5" (38 mm) of micro leveling at the wall.



Mount shifts left/right at the wall installation, and uprights shift left/right along crossbar.

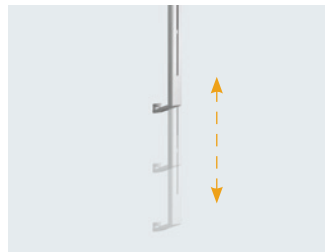

Telescoping legs allow the interactive board to be positioned from the top of the existing board all the way to the floor. Mount anchors at four points.



Combine with WBAP2 Projector Platform for an all-in-one mounting solution when using the SMART® UX60 , UF65 & UF75 short throw projectors.

SPECIFICATIONS

Model	Extension	Leveling	Lateral Shift	Weight Capacity	Color
WBM3E Telescoping Whiteboard Wall Mount	58 - 83" (1470 - 2100 mm)	1.5"	30" (762 mm)	125 lbs (56.7 kg)	

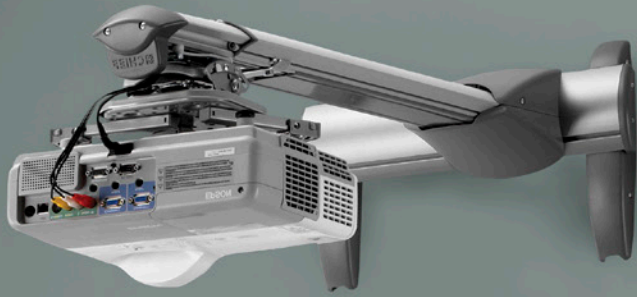

CEILING ADAPTERS



CMA105	Weight Capacity
Ceiling Plate - 4" (102 mm)	500 lbs (226.8 kg)



CMA110	Color	Weight Capacity
Ceiling Plate - 8" (203 mm)		500 lbs (226.8 kg)



CMA115	Color	Weight Capacity
Ceiling Plate - 6" (152 mm)		500 lbs (226.8 kg)



CMA101	Color	Weight Capacity
Designer Ceiling Plate		500 lbs (226.8 kg)



CMS115	Color	Weight Capacity
Speed-Connect™ Ceiling Plate		500 lbs (226.8 kg)



CMA330	Weight Capacity
Offset Ceiling Plate - 8" (203 mm)	500 lbs (226.8 kg)



CMA345	Weight Capacity
Shock Absorption Ceiling Plate	500 lbs (226.8 kg)



CMA395	Colors	Weight Capacity
Angled Ceiling Plate		500 lbs (226.8 kg)



CMA360	Weight Capacity
I-Beam Clamp	250 lbs (113.4 kg)



CMA365	Weight Capacity
Truss Ceiling Adapter	250 lbs (113.4 kg)



CMS390/391	Weight Capacity
Dual Joist Ceiling Adapters - 16" (406 mm) / 24" (609 mm)	500 lbs (226.8 kg)



CMA362	Weight Capacity
C-Clamp	250 lbs (113.4 kg)



CMA366	Weight Capacity
Architectural Spanning Adapter	250 lbs (113.4 kg)



CMS495	Weight Capacity
Angled Suspended Ceiling Adapter	50 lbs (22.7 kg)

SUSPENDED CEILING KITS



CMA440	Weight Capacity
Above-Tile Suspended Ceiling Kit	50 lbs (22.7 kg)



CMS440	Weight Capacity
Speed-Connect Above-Tile Suspended Ceiling Kit	50 lbs (22.7 kg)



CMS440P2	Weight Capacity
Speed-Connect Above-Tile Suspended Ceiling Kit with 2-Gang SurgeX® Receptacle	50 lbs (22.7 kg)

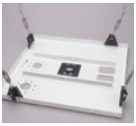

CMA450	Weight Capacity
Heavy Duty Suspended Ceiling Kit	250 lbs (113.4 kg)



CMA455	Weight Capacity
Suspended Ceiling Tile Replacement Kit	250 lbs (113.4 kg)



CMS445	Weight Capacity
Speed-Connect Suspended Ceiling Tile Replacement Kit	50 lbs (22.7 kg)



CMS445P2	Weight Capacity
Suspended Ceiling Replacement Kit with 2-Gang SurgeX® Receptacle	50 lbs (22.7 kg)

STORAGE SOLUTIONS



CMA470	Compatibility
Above-Tile Storage Accessory	CMS440, CMA440, CMA450 and CMA455 ceiling kits



CMA471	Compatibility
Large Above-Tile Storage Accessory	CMS440, CMA440, CMA450 and CMA455 ceiling kits

STORAGE SOLUTIONS - PLENUM RATED

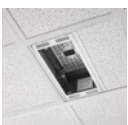

CMS491	Weight Capacity
Half Tile Plenum Storage Box	100 lbs (45 kg)



CMS491C	Weight Capacity
Half Tile Plenum Storage Box w/ Column Drop	100 lbs (45 kg)

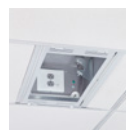

CMS491P2	Weight Capacity
Half Tile Plenum Storage Box w/ 2-Gang SurgeX Receptacle	100 lbs (45 kg)



CMS491CP2	Weight Capacity
Half Tile Plenum Storage Box and Column Drop w/ 2-Gang SurgeX Receptacle	100 lbs (45 kg)



CMS492	Weight Capacity
Full Tile Plenum Storage Box	100 lbs (45 kg)



CMS492C	Weight Capacity
Full Tile Plenum Storage Box w/ Column Drop	100 lbs (45 kg)



CMS492P2	Weight Capacity
Full Tile Plenum Rated Storage Box w/ 2-Gang SurgeX Receptacle	100 lbs (45 kg)



CMS492CP2	Weight Capacity
Full Tile Plenum Rated Storage Box and column drop w/ 2-Gang SurgeX Receptacle	100 lbs (45 kg)



CMA472	Compatibility
Plenum Rated Above-Tile Storage Accessory	CMS440, CMA440



CMA473	Compatibility
XL Plenum Storage Enclosure	CMS440, CMA440

EXTENSION



CMS Fixed Columns		Weight Capacity	
Fixed 1 1/2" NPT extension columns available in black, silver and white†		500 lbs (226.8 kg)	
Model	Length	Model	Length
CMS003*	3" (76 mm)	CMS024	2' (0.6 m)
CMS006*	6" (152 mm)	CMS036	3' (0.9 m)
CMS009	9" (229 mm)	CMS048	4' (1.2 m)
CMS012	12" (305 mm)	CMS060	5' (1.5 m)
CMS018	18" (457 mm)	CMS072	6' (1.8 m)

** Steel construction. † All part numbers listed are black. To order alternate colors add an S (silver) or W (white) to the end of the part number.*



CMS Fixed Columns		Weight Capacity	
Fixed 1 1/2" NPT extension columns available in black, silver and white†		500 lbs (226.8 kg)	
Model	Length	Model	Length
CMS006009	6-9" (152-229 mm)	CMS0507	5-7' (1.5-2.1 m)
CMS009012	9-12" (229-305 mm)	CMS0608	6-8' (1.8-2.4 m)
CMS012018	12-18" (305-457 mm)	CMS0709	7-9' (2.1-2.7 m)
CMS018024	18-24" (457-610 mm)	CMS0810	8-10' (2.4-3.1 m)
CMS0203	2-3' (0.6-0.9 m)	CMS0911	9-11' (2.7-3.4 m)
CMS0305	3-5' (0.9-1.5 m)	CMS1012*	10-12' (3.1-3.7 m)
CMS0406	4-6' (1.2-1.8 m)		

** Cannot ship by UPS due to length. † All part numbers listed are black. To order alternate colors add an S (silver) or W (white) to the end of the part number.*



CMA274/275	Compatibility
Quick-Snap Cable Covers - (Qty 1 / Qty 3) 4" (101 mm) long Available in black or white	1 1/2" & 2" NPT Columns



CMA640	Compatibility	Color
Decorative Ring, 1.9" (48 mm) ID	1 1/2" NPT & CPA Columns	

IN-LINE ADAPTERS



CMA351	Weight Capacity
Heavy Duty Swivel Adapter	500 lbs (226.8 kg)



CMA152	Weight Capacity
Threaded Pipe Coupler with Cable Slot	500 lbs (226.8 kg)



CMA270	Color	Weight Capacity
Threaded Pipe Coupler		500 lbs (226.8 kg)



CMA170	Weight Capacity
Storage Accessory	25 lbs (11.3 kg)



CMA480	Weight Capacity
Column Storage Shelf	25 lbs (11.3 kg)



CMA347	Weight Capacity
Vibration Isolating Coupler	35 lbs (15.9 kg)

SECURITY



PG1A	Max Equipment Size (HxWxD)	Colors
Large Projector Guard	7.5 x 20 x 20.4" (191 x 508 x 518 mm)	



PG2A	Max Equipment Size (HxWxD)	Colors
Small Projector Guard	7.5 x 16 x 16" (191 x 406 x 406 mm)	



PG3A	Max Equipment Size (HxWxD)	Colors
Extra Large Projector Guard	11.4 x 25 x 24.9" (288 x 635 x 633 mm)	W B



HC1	Includes
Heavy-Duty Cable System	SA1, cable, padlock, security pads, super glue

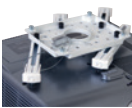

SEC2	Compatibility
Security Cable Kit for SLBU	RSMA and RSA Mounts and RPA and RPA Elite Security Series

AUTOMATED LIFT ACCESSORIES



IR10	Compatibility
Infrared Remote Control	SL151, SL236, and SL220



RC10	Compatibility
RF Remote Control	SL151 and SL236



ASP401	Compatibility
Individual Control System	SL151, SL236, and SL220



SMA602	Compatibility
Smart-Lift Single Column Mounting Plate	SL151 and SL236



SMA620	Compatibility
Suspended Ceiling Installation and Track Clip Kit	SL236



SMA651	Compatibility
Threaded Rod Adapter	SL236

UPB1	Compatibility
Smart-Lift Upright Projector Interface Bracket	SL151

SHORT THROW ACCESSORIES



WMA1S	Compatibility	Weight Capacity
Wall Mount Arm	CMS columns up to 4' (1.2 m)	150 lbs (68 kg) wood/concrete, 50 lbs (22.7 kg) steel stud



WMA2S	Compatibility	Weight Capacity
Wall Mount Arm with Lateral Shift	CMS columns up to 4' (1.2 m)	150 lbs (68 kg) wood/concrete, 75 lbs (34 kg) steel stud



WMAL24	Compatibility
24" (610 mm) Stud Accessory	WM2 Series Wall Mounts



WMAL72	Compatibility
72" (183 cm) Multi-stud Accessory	WM2 Series Wall Mounts



WMAC16	Compatibility
Wall Cover	WM2 Series Wall Mounts



WMAH3S	Compatibility
3" (76 mm) Height Adjust Accessory	WM2 Series Wall Mounts



A BRAND OF MILESTONE AV TECHNOLOGIES | www.milestone.com

USA P 866.977.3901 E chief@chiefmfg.com

CANADA P 877.345.4329 E canadainfo@milestone.com

EMEA P +31 495 580 840 E emea.sales@milestone.com

APAC P +852 2145 4099 E asia.chief@milestone.com

In British Columbia, Milestone AV Technologies ULC carries on business as MAVT Milestone AV Technologies ULC.

©2016 Milestone AV Technologies. 1500129A 2/16 Chief is a registered trademark of Milestone AV Technologies. All other brand names or marks are used for identification purposes and are trademarks of their respective owners. All patents are protected under existing designations. Other patents pending.

milestone

Milestone AV Technologies is home of Chief, Da-Lite, Sanus and Projecta. Across these brands, Milestone produces a wide range of innovative audiovisual solutions.