

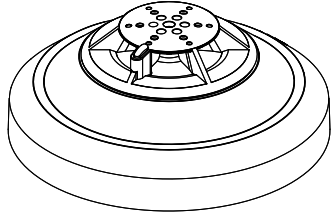

1609 Park 370 Pl, Hazelwood, MO 63042  
www.pottersignal.com



### PAD300-HD



#### Contents

A. Introduction	E. Addressing
B. Specifications	F. Testing
C. Installation	G. Warranty
D. Locking Feature	

## A. Introduction

The PAD300-HD is an intelligent addressable thermal detector with a programmable fixed temperature and a 15°F/min rate of rise alarm.

Each detector includes one (1) LED to indicate the device status. The LED flashes momentarily in normal conditions and flashes at a fast rate when activated. The LED can be turned off using the programming software.

The PAD300-HD is listed on maximum 70 ft spacing with alarm set point from 135°F to 185°F on smooth ceiling. Refer to NFPA 72 for specific information regarding detector spacing, placement and special applications.

The PAD300-HD communicates on a proprietary protocol to the addressable fire alarm control panel. It must be connected to either the IPA series, AFC series, or ARC fire alarm control panel for proper operation. For detector sensitivity settings and supervision, please refer to the panel installation instructions.

Refer to the company website for the latest revision of this manual.

## B. Specifications

PAD300-HD	
<b>Operating Voltage</b>	24 VDC
<b>Standby Current (*)</b>	300 µA
<b>Alarm Indicator Current</b>	1.4 mA
<b>Alarm Temp Rating</b>	135°F to 174°F
<b>Installation Temp Range</b>	32°F to 115°F
<b>Alarm Temp Rating</b>	175°F to 185°F
<b>Installation Temp Range</b>	32°F to 150°F
<b>Operating Humidity Range</b>	0% - 93% (Non-condensing)
<b>Dimension</b>	Φ 3.93 in
<b>Weight</b>	2.4 oz
<b>Height</b>	1.5 in

\*Standby current is the current the device consumes when the device is in a non-activated condition and where no communication current is transmitted to the fire alarm control panel.

#### Sensitivity-Spacing Allocation:

The sensitivity of PAD300-HD heat detector is expressed in terms of spacing limitations. Spacing limitations refer to the maximum distance permitted between heat detectors mounted on smooth ceilings.

See below table for the UL521 spacing limitations.

	Spacing Allocation
<b>Fixed Temperature 135°F to 185°F</b>	70 ft
<b>w/ Rate of Rise 15°F/min</b>	70 ft

**NOTE:** THE DEFAULT FIXED ALARM TEMPERATURE IS 135°F WITH THE RATE-OF-RISE FUNCTION DISABLED. BOTH SETTINGS CAN BE CHANGED IN THE POTTER PROGRAMMING SOFTWARE. FOR FURTHER INFORMATION, REFER TO THE CONTROL PANEL INSTALLATION INSTRUCTIONS.

## C. Installation

Installation must meet the requirements of the Authority Having Jurisdiction (AHJ). It is recommended to follow guidelines as described in NFPA 72.

- Before connecting a device to the SLC loop, take the following precautions to prevent potential damage to the SLC or device.
  - Use only the PAD300 series bases PAD300-4DB, PAD300-6DB, PAD300-SB, PAD300-LFSB (supplied separately).
  - Confirm the field wiring on device is correctly installed on the base. Refer to the base manual.
  - Enable the locking feature if needed. Refer to section D for details of the locking feature.
- Set the desired address using the DIP switch located on back of the sensor. See section E for addressing instructions.
- Plug detector into base and turn clockwise to secure in place.

**CAUTION** DETECTORS ARE NOT TO BE USED WITH DETECTOR GUARDS UNLESS THE COMBINATION HAS BEEN EVALUATED AND FOUND SUITABLE FOR THAT PURPOSE.

## D. Locking Feature

The device includes a tamperproof feature that locks the detector and does not allow removal without the use of a tool.

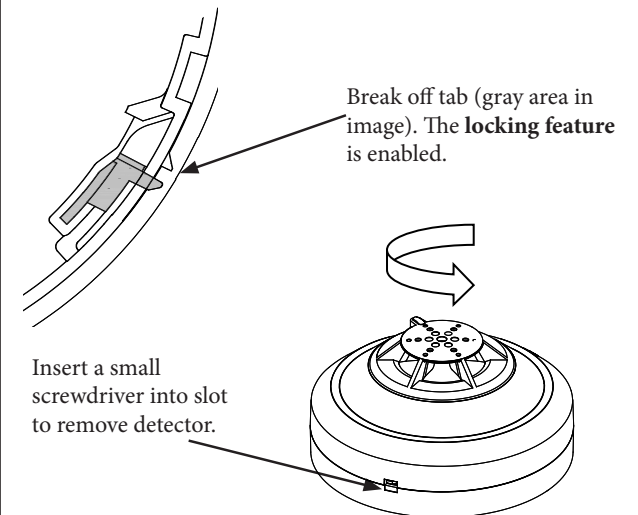

## E. Addressing

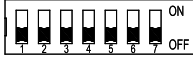

Detector address can be configured using the table below for DIP switch position settings.

POS	DIP Switch on	POS	DIP Switch on	POS	DIP Switch on
1	1	43	1,2,4,6	85	1,3,5,7
2	2	44	3,4,6	86	2,4,5,7
3	1,2	45	1,3,4,6	87	1,2,3,5,7
4	3	46	2,3,4,6	88	4,5,8
5	1,3	47	1,2,3,4,6	89	1,4,5,7
6	2,3	48	5,6	90	2,4,5,7
7	1,2,3	49	1,5,6	91	1,2,4,5,7
8	4	50	2,5,6	92	3,4,5,7
9	1,4	51	1,2,5,6	93	1,3,4,5,7
10	2,4	52	3,5,6	94	2,3,4,5,7
11	1,2,4	53	1,3,5,6	95	1,2,3,4,5,7
12	3,4	54	2,3,5,6	96	6,7
13	1,3,4	55	1,2,3,5,6	97	1,6,7
14	2,3,4	56	4,5,6	98	2,6,7
15	1,2,3,4	57	1,4,5,6	99	1,2,6,7
16	5	58	2,4,5,6	100	3,6,7
17	1,5	59	1,2,4,5,6	101	1,3,6,7
18	2,5	60	3,4,5,6	102	2,3,6,7
19	1,2,5	61	1,3,4,5,6	103	1,2,3,6,7
20	3,5	62	2,3,5,5,6	104	4,6,7
21	1,3,5	63	1,2,3,4,5,6	105	1,4,6,7
22	2,3,5	64	7	106	2,4,6,7
23	1,2,3,5	65	1,7	107	1,2,4,6,7
24	4,5	66	2,7	108	3,4,6,7
25	1,4,5	67	1,2,7	109	1,3,4,6,7
26	2,4,5	68	3,7	110	2,3,4,6,7
27	1,2,4,5	69	1,3,7	111	1,2,3,4,6,7
28	3,4,5	70	2,3,7	112	5,6,7
29	1,3,4,5	71	1,2,3,7	113	1,5,6,7
30	2,3,4,5	72	4,7	114	2,5,6,7
31	1,2,3,4,5	73	1,2,4,7	115	1,2,5,6,7
32	6	74	3,4,7	116	3,5,6,7
33	1,6	75	1,3,4,7	117	1,3,5,6,7
34	2,6	76	2,3,4,7	118	2,3,5,6,7
35	1,2,6	77	1,3,4,7	119	1,2,3,5,6,7
36	3,6	78	2,3,4,7	120	4,5,6,7
37	1,3,6	79	1,2,3,4,7	121	1,4,5,6,7
38	2,3,6	80	5,7	122	2,4,5,6,7
39	1,2,3,6	81	1,5,7	123	1,2,4,5,6,7
40	4,6	82	2,5,7	124	3,4,5,6,7
41	1,4,6	83	1,2,5,7	125	1,3,4,5,6,7
42	2,4,6	84	3,5,7	126	2,3,4,5,6,7
		127	1,2,3,4,5,6,7		

## F. Testing

Testing must meet the requirements of the Authority Having Jurisdiction (AHJ). It is recommended to follow guidelines as described in NFPA 72.

It is important to test the product after installation and periodically to ensure it functions probably.

**⚠ CAUTION** NOTIFY APPROPRIATE AUTHORITY BEFORE TESTING THE DETECTOR. PLACE FIRE PANEL IN *WALK TEST* MODE BEFORE CONDUCTING THE FOLLOWING TEST. REFER TO THE PANEL INSTALLATION MANUAL FOR DETAIL.

### Heat Test

Use hair dryer or heat gun to direct the heat toward the side of the detector. Keep at a distance of 6 in or 15 cm to avoid overheating.

Units failing the heat test should be serviced.

### Magnet Test

The magnet test provides a quick test to verify the connections and the detector electronically. This test should not replace the aerosol test, which is required as part of regular testing and maintenance per NFPA 72.

1. Hold the test magnet in the magnet test area as shown below.

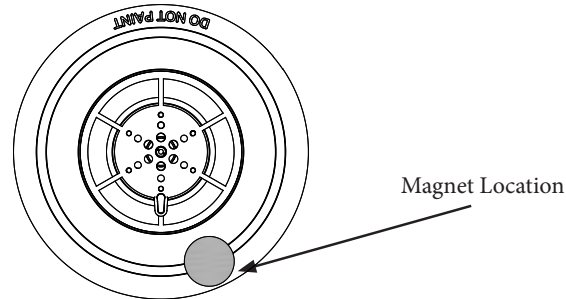

2. The LED flashes rapidly to indicate the detector is in alarm.
3. Remove magnet.
4. Alarm on the fire alarm panel should be reset.
5. Unit failed the magnet test should be tested again with heat gun or hair dryer to confirm the failure.

## G. Warranty

POTTER warrants that the equipment herein shall conform to said descriptions as to all affirmation of fact and shall be free from defects of manufacture, labeling, and packaging for a period of five (5) years from the invoice date to the original purchaser, provided that representative samples are returned to POTTER for inspection. The product warranty period is stated on the exterior of the product package. Upon a determination by POTTER that a product is not as warranted, POTTER shall, at its exclusive option, replace or repair said defective product or parts thereof at its own expense, except that Purchaser shall pay all shipping, insurance, and similar charges incurred in connection with the replacement of the defective product or parts thereof. This Warranty is void in the case of abuse, misuse, abnormal usage, faulty installation, or repair by unauthorized persons, or if for any other reason POTTER determines that said product is not operating properly as a result of causes other than defective manufacture, labeling, or packaging.