

# Jasco Z-Wave In-wall Toggle Smart Dimmer

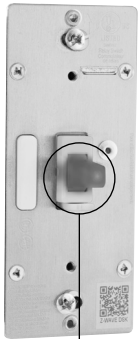

New blue LED backlit toggle

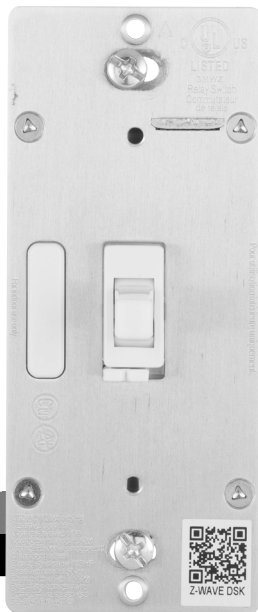

## Specifications

**Power:** 120VAC, 60Hz **Signal Frequency:** 908.4/916MHz  
**Maximum Load:** 600W Incandescent, 300 Dimmable CFL/LED  
**Range:** Up to 150 feet from controller or closest Z-Wave device  
**Operating Temperature:** 32-104° F (0-40° C)  
**Warranty:** 5-year limited product warranty

**Requires neutral wire. Switch must be mounted indoors**

## Design Features

- QuickFit™ – Improved components reduce the housing depth by up to 20 percent compared to previous Z-Wave models and eliminated the need for heat tabs
- SimpleWire™ – Auto line-load sensing terminals support fast installation by detecting line and load wires and configuring the switch accordingly
- Dual ground ports, which are offset to avoid switch box mounting screws, support daisy-chaining in multi-switch setups
- Remotely monitor with any mobile device\*
- Works with Google and Alexa (requires compatible hub\*)
- May be used in single pole installation or with up to four Jasco model 46561 Add-on switches in 3, 4, 5 or 6-way wiring configurations
- Works with most dimmable LED, CFL, halogen and all incandescent bulbs
- Turn ON/OFF and control the brightness level of the connected lighting manually or via Z-Wave hub or controller
- New blue LED backlit toggle (with 4 adjustable settings)
- UL Listed to work with dimmable LED & CFLs
- Can be Included in multiple Groups and Scenes
- Utilizes the Z-Wave Firmware Update Meta Data command class for standardized firmware updates Over the Air
- Supports Advanced Configuration; Dim rates, Alternate exclusion and minimum and maximum dim levels
- Full Range Dimmability; adjust brightness level from 0-100% in 1% increments
- Screw Terminal installation; requires wiring connections for Line (Hot), Load, Neutral and Ground. Traveler wire required for multi pole installation
- Use a standard toggle wall plate (wall plate not included)
- LED status can be inverted manually changed to invert, always OFF and always ON
- Inline traveler circuit protection
- Z-Wave Plus Certified

## Z-Wave Plus with S2 Security and SmartStart Feature

- Improved battery life and up to 50 percent greater wireless range
- QR codes with unique, industry-standard secure key exchange to add a layer of 128-bit encryption
- Effortless device pairing to Z-Wave S2 and SmartStart certified gateways
- Backward compatible with all generations of Z-Wave devices
- 250% faster processor
- 400% more memory
- 50% more energy efficient
- Supports wireless upgrades to future-proof your home

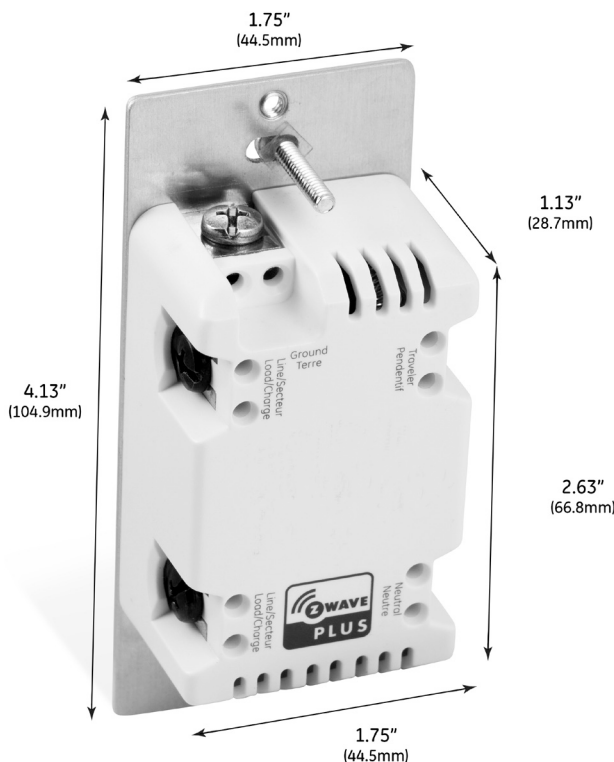

\* Requires Z-Wave hub or controller, functions may vary depending on brand.

Single Location Wiring

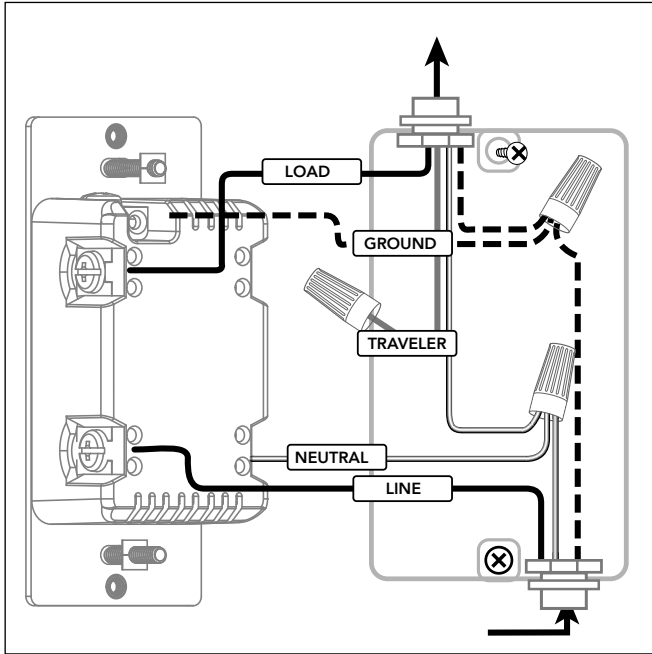

Space-Saving Screw Terminals

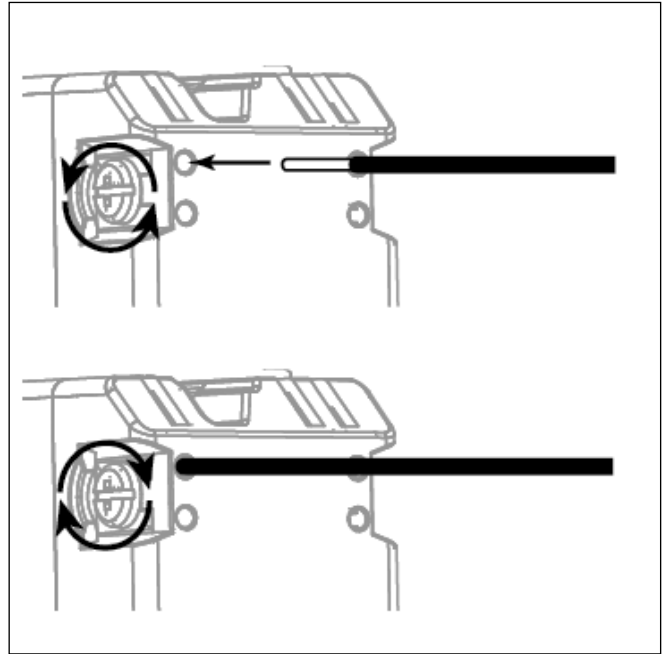

Multi-Location Wiring

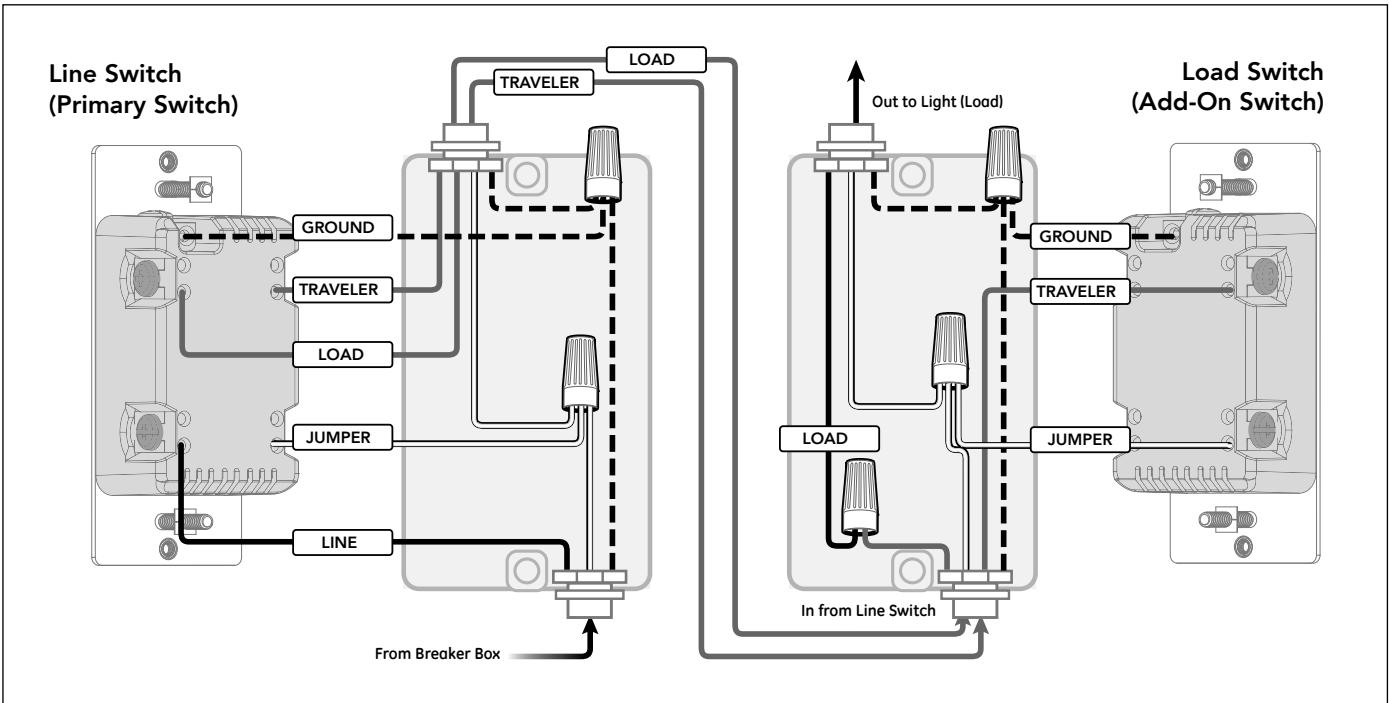

Installation Recommendations:

- Insert wire into port and tighten screw. Do not wrap wire around screw
- Indoor use only
- Visit <http://www.ezwave.com/hubs> for hub compatibility
- Wallplates sold separately
- Trilingual Instruction manual – (English, French, Spanish)

**Device Configuration**

**Adding your device to a Z-Wave network**

Once the hub is ready to add your smart switch, press up or down on the smart toggle switch to add it in the network.

**To remove and reset the device**

Once the controller is ready to remove your device, press up or down on the smart toggle switch to remove it from the network.

**S2 + SmartStart install**

The controller's app will indicate if it has discovered the sensor. If prompted by the controller to enter the S2 security code, refer to the QR code/security number on the back of the box, or the QR code label on the product. Enter the 5-digit code.

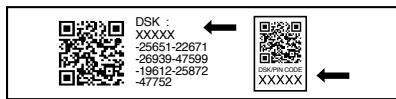

**To return to factory defaults**

Quickly press up on the toggle 3 times, then press the down on the toggle 3 times.

**Certifications & Compliances**



Compliances, specifications and availability are subject to change without notice.

Distributed by Jasco Products Company LLC  
10 E. Memorial Rd., Oklahoma City, OK

Questions? Contact our U.S.-based Consumer Care at  
1-800-654-8483 between 7AM-8PM, M-F, Central Time.

©Jasco 2021

**Related Products - Jasco Z-Wave Smart Controls**



**46561**  
Add-On  
Switch



**46563**  
In-Wall  
Smart Switch

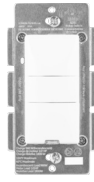

**24770**  
In-Wall Smart  
Motion Switch



**26932**  
In-Wall Smart  
Motion Dimmer



**55257**  
In-Wall  
Smart Outlet  
CAV



**55259**  
In-Wall Smart  
Fan Control  
CAV