

### DESCRIPTION

Nascom's High Security UL Level 2 BMS, patent pending design utilizes multiple magnetic fields; providing the most advanced magnetic high security switch in the world. Applications include government facilities, bank safes and vaults.

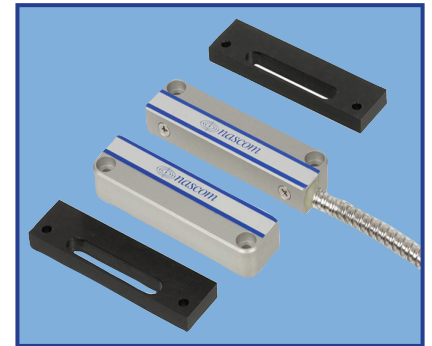

### FEATURES

- SMALL FOOTPRINT
- DOUBLE RESISTANT TAMPER
- UNIVERSAL MOUNT - LEFT OR RIGHT
- 24" ARMORED CABLE (STANDARD)
- ANODIZED ALUMINUM SWITCH AND MAGNET HOUSING
- EPOXY ENCAPSULATED HERMETICALLY SEALED CONTACTS
- LISTED TO UL634 STANDARD
- SUITABLE FOR INDOOR OR OUTDOOR USE

### SPECIFICATIONS

PARAMETERS	CONDITION	MIN	TYP	MAX	UNITS
<b>CONTACT RATINGS — ALARM CIRCUIT</b>					
Operate Gap		0.000		0.125	inches
Release Gap		0.125		0.150	Inches
Side-to-side offset				0.125	Inches
Front-to-back offset Operate				0.625	Inches
Front-to-back offset Release				0.750	Inches
Switching Voltage	Max DC/Peak AC Resistive			30	VDC
Switching Current	Max DC/Peak AC Resistive			0.020	Amps
Carry Current	Max DC/Peak AC Resistive			0.020	Amps
Contact Rating	Max DC/Peak AC Resistive			0.600	VA
Life Expectancy	1V, 10mA Signal Level		1.00E+06		Ops
Static Contact Resistance	50mV, 10mA			400	mOhms
Contact Material			Au		

<b>CONTACT RATINGS — TAMPER CIRCUIT</b>					
Operate Gap		0.000		0.125	Inches
Release Gap	With spaces under switch and magnet			0.093	Inches
Switching Voltage	Max DC/Peak AC Resistive			30	VDC
Switching Current	Max DC/Peak AC Resistive			0.020	Amps
Carry Current	Max DC/Peak AC Resistive			0.020	Amps
Contact Rating	Max DC/Peak AC Resistive			0.600	VA
Life Expectancy	1V, 10mA Signal Level		1.00E+06		Ops
Static Contact Resistance	50mV, 10mA			400	mOhms
Contact Material			Au		

<b>CIRCUIT INFORMATION</b>					
Alarm Circuit	Closed Loop / Normally Open				
Tamper Circuit	Closed Loop / Normally Open				

<b>SWITCH SPECIFICATIONS</b>					
Insulation Resistance	100V, 25°C, 40% RH	1.00E+09			Ohms
Capacitance	Across Open Contacts	250			VDC/PeakAC
Dielectric Strength	Between Contacts				

<b>ENVIRONMENTAL RATINGS</b>					
Storage Temperature		-35		+66	°C
Operating Temperature		-35		+66	°C

## WIRING SCHEMATIC

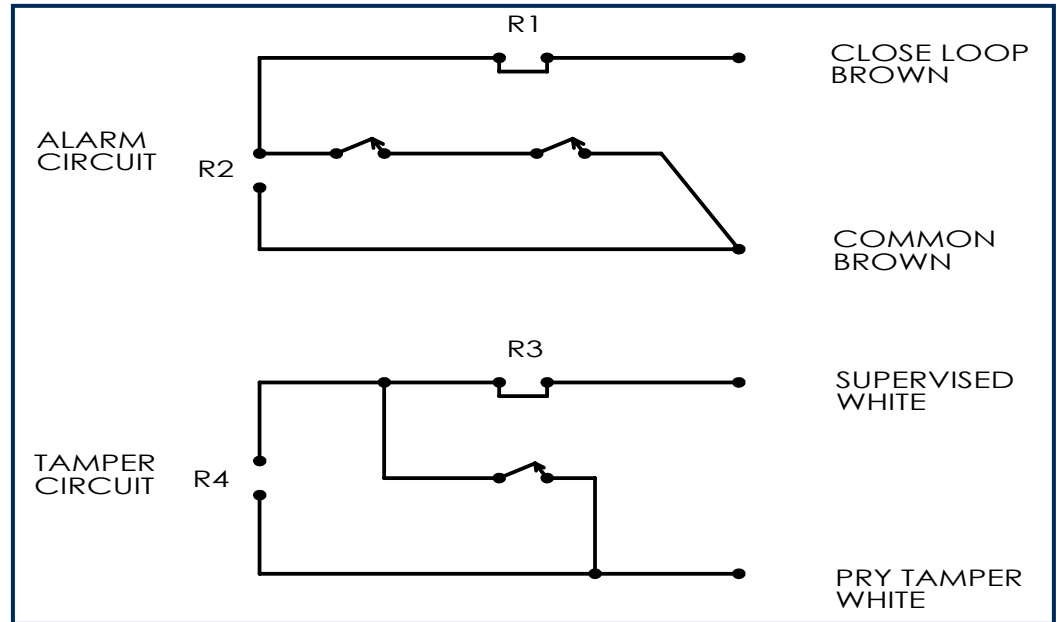

## DIMENSIONS - IN [mm]

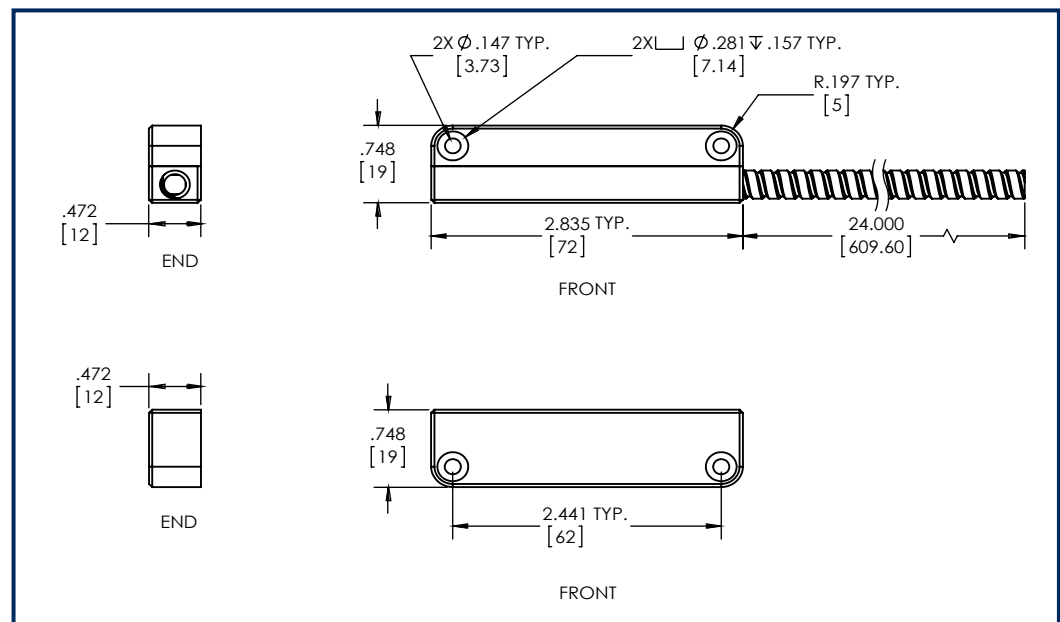

## ORDERING INFORMATION

PART NUMBER	DESCRIPTION
N707AU/ST	Switch and e-strike magnet set
N707AU/STATS	Switch and e-strike magnet set with alarm and tamper circuits connected in series
N707AU/SW	Switch only
N707AU/SWATS	Switch with alarm and tamper circuits connected in series
N707AU/M	E-strike magnet only
N707AUSPKIT	Spacer kit
N707AU/STR1xx	Switch and e-strike magnet set with alarm circuit resistor in series — xx=resistor value
N707AU/STR1xxR2xx	Switch and e-strike magnet set with alarm circuit R1 resistor in series and R2 resistor in parallel — xx=resistor value
N707AU/STR3	value
N707AU/STR3xxR4xx	Switch and e-strike magnet set with tamper circuit resistor in series — xx=resistor value
N707AU/STR1xxR3xxR4xx	Switch and e-strike magnet set with tamper circuit R1 resistor in series and R2 resistor in parallel — xx=resistor value
N707AU/STR1xxR2xxR3xx	Switch and e-strike magnet set with alarm circuit resistor in series and tamper circuit R1 resistor in series and R2
N707AU/STR1xxR3xx	resistor in parallel — xx=resistor value
N707AU/STR1xxR2xxR3xxR4xx	Switch and e-strike magnet set with alarm circuit R1 resistor in series and R2 resistor in parallel and tamper circuit resistor in series — xx=resistor value
	Switch and e-strike magnet set with alarm and tamper circuits resistor in series — xx=resistor value
	Switch and e-strike magnet set with alarm and tamper circuit R1 resistor in series and R2 resistor in parallel — xx=resistor value

### EXAMPLE:

N707AU/STR11KR21KR31KR41K	N707AU E=Strike set with alarm circuit 1K resistor in series, 1K resistor in parallel, and tamper circuit 1K resistor in series, 1 K resistor in parallel
---------------------------	---

## INSTALLATION INSTRUCTIONS

This level 2 BMS is to be connected / used with UL Listed Burglar Panels / Systems, Switch and Magnet must be aligned for correct operation!

### WOOD DOORS — NON FERROUS APPLICATIONS:

Mount in desired location and orientation using #6 pan-head screws with a minimum recommended length of 1/2 inch.

To ensure the highest security, keep the gap as small as practical. A 1/32" gap is recommended but the switch will operate at a maximum 1/8" gap.

The flexible cable may exit the switch from either the left or the right side by removing the two #4 flathead machine screws located on the base of the switch and flipping the switch 180°. Refasten the screws but DO NOT OVERTIGHTEN THE SCREWS.

After the switch and magnet have been mounted, remove the SWITCH BASE and temporarily mount the TAMPER INSERT, using the same #6 screws, in the same location that was used to mount the SWITCH BASE. Permanently mount the TAMPER INSERT using a third #6 screw in the location shown in the drawing. Remove the SWITCH BASE mounting screws and re-install the switch base over the TAMPER INSERT. The tamper circuit will alarm before the switch can be removed.

### STEEL DOOR AND FERROUS SURFACE APPLICATIONS:

When mounting the switch and magnet on ferrous surfaces such as steel doors and safes, follow the above installation instructions, but you must also install the enclosed 1/4" thick spacers under the switch and magnet to achieve a 1/8" operate gap.

Use #6 screws (stainless steel recommended) with a minimum recommended length of 1-1/2".

Use Spacer Kit (part number: N707AUSPKIT) for installation on offset surfaces to achieve correct alignment.