



Video • Data • Power

HubSat4D Series

Passive UTP Transceiver Hub with
Integral Camera Power

Models Include:

HubSat4D

- Four (4) Channel Passive UTP Transceiver Hub with Integral Camera Power

HubSat42D

- Four (4) Channel Passive UTP Transceiver includes
Four (4) HubWayAv Video Balun/Combiners

HubSat43D

- Four (4) Channel Passive UTP Transceiver includes
Four (4) HubWayDv Video Balun/Combiners

Installation Guide



Rev. 112408

More than just power.™

Installing Company: _____ Service Rep. Name: _____

Address: _____ Phone #: _____

Table of Contents:

Overview	<i>pg. 3</i>
Specifications	<i>pg. 3</i>
Additional Models	<i>pg. 3</i>
Installation Instructions	
HubSat4D Passive UTP Transceiver Hub with Integral Camera Power	<i>pg. 3</i>
HubSat4D for Use as a Remote Accessory Module with HubWay/HubWayLD/HubWayLDH UTP Transceiver Hubs	<i>pg. 4</i>
Alternate 24VAC Fixed Camera Hookup	<i>pg. 5</i>
HubSat Circuit Board	<i>pg. 6</i>
HubWayAv, HubWayAv2, HubWayDv, and HubWayDvi Video Balun/Combiners	<i>pg. 7</i>
CAT-5 Structured Cable Wiring Color Codes	<i>pg. 7</i>
Typical Application Drawings	
HubSat4D Passive UTP Transceiver Hub with Integral Camera Power	<i>pg. 9</i>
HubSat4D Remote Accessory Module with HubWay UTP Transceiver Hubs	<i>pg. 9</i>
Enclosure Dimensions	<i>pg. 12</i>

Overview:

Altronix HubSat4D Passive UTP Transceiver Hub with Integral Camera Power transmits UTP video, RS422/RS485 data and power over a single CAT-5 or higher structured cable. Unit provides 4 camera channels in a wall mount enclosure. Video transmission range is up to 750 ft. max. per channel. Units are compatible with AC and/or DC fixed or PTZ cameras when utilizing Altronix HubWayAv, HubWayAv2, HubWayDv or HubWayDvi Video Balun/Combiners. In addition, the unit features individually selectable 24VAC or 28VAC PTC protected outputs with surge suppression. Optionally, the HubSat4D can be used as an accessory module to transmit video from up to 4 cameras over a single CAT-5 or higher structured cables back to the HubWay, HubWayLD or HubWayLDH Passive and Active UTP Transceiver Hubs. In addition, the HubSat4D provides power to these cameras locally to eliminate the possibility of voltage drop associated with long cable runs.

Specifications:

Agency Listings:

- UL Listed for Commercial CCTV Equipment (UL 2044).
- cUL Listed - CSA Standard C22.2 No.1-04, Audio, Video and Similar Equipment.
- CE European Conformity

Input:

- 115VAC, 60Hz, 1.25A.
- Primary in-line fuse is rated @ 3.5A/250V.

Video:

- Four (4) channels of quality video over twisted pair up to a distance of 750 ft. per channel.
- Four (4) 75 Ohm video outputs.

Data:

- RS422/RS485 data input.

Power:

- Individually selectable 24VAC or 28VAC power outputs with OFF position.
- Unit provides up to 1A max. per channel not to exceed a total of 4A maximum current.
- PTC protected outputs are rated @ 1A per channel.
- Surge suppression.

Visual Indicators:

- Four (4) power LED indicators.

Enclosure Dimensions (H x W x D approx.):

8.5" x 7.5" x 3.5" (215.9mm x 190.5mm x 88.9mm).

Optional Accessories:

- Video Balun/Combiners:
 - HubWayAv: for use with 24VAC cameras.
 - HubWayAv2: for use with 24VAC cameras.
 - HubWayDv: for use with 12VDC cameras.
 - HubWayDvi: for use with non-isolated 12VDC cameras.

Additional Models:

HubSat42D

- HubSat4D with four (4) HubWayAv Video Balun/Combiners for 24VAC Cameras.

HubSat43D

- HubSat4D with four (4) HubWayDv Video Balun/Combiners for 12VDC Cameras.

Installation Instructions:

WARNING: To reduce the risk of fire or electric shock do not expose the unit to rain or moisture.

This installation should be made by qualified service personnel and should conform to all local codes.

HubSat4D Passive UTP Transceiver Hub with Integral Camera Power.

1. Mount unit in desired location. Mark and predrill holes in the wall to line up with the top two keyholes in the enclosure. Install two upper fasteners and screws in the wall with the screw heads protruding. Place the enclosure's upper keyholes over the two upper screws; level and secure. Mark the position of the lower two holes. Remove the enclosure. Drill the lower holes and install the two fasteners. Place the enclosure's upper keyholes over the two upper screws. Install the two lower screws and make sure to tighten all screws (*Enclosure Dimensions, pg. 8*). Secure green wire lead to earth ground.
2. Set illuminated master power disconnect circuit breaker to the [OFF] position (*Fig. 5a, pg. 8*).
3. Connect 115VAC 60Hz to the black and white flying leads of open frame transformer. Secure ground wire (Green) to earth ground (*Fig. 5, pg. 8*).
4. Select 24VAC or 28VAC power output for each of the Channels 1-4 on HubSat (*Fig. 5, pg. 8*) with the corresponding output voltage switches. Select OFF position when servicing or installing individual cameras (*Fig. 1d, pg. 6*).
5. Connect the BNC video outputs marked [Video 1-4] on HubSat to the corresponding video inputs on the head end equipment (DVR) (*Fig. 1a, pg. 6*).

6. Connect terminals marked [+ DATA -] on HubSat (polarity must be observed) to the RS422/RS485 output of the head end equipment (DVR) (Fig. 1f, pg. 6). When using fixed cameras disregard this step.
7. Plug the RJ45 connector at one end of the CAT-5 or higher structured cable into the RJ45 jack marked [PVD1] on HubSat (Fig. 1i, pg. 6). Plug the RJ45 connector at the opposite end of the CAT-5 or higher structured cable into the RJ45 jack of the Video Balun/Combiner to be installed at camera 1.
 - For 24VAC cameras use Altronix model HubWayAv/HubWayAv2 Video Balun/Combiner (Figs. 2a, 2b, 2e, pg. 7).
 - For 12VDC cameras use Altronix model HubWayDv Video Balun/Combiner (Figs. 2c, 2d, pg. 7).
 - For non-isolated 12VDC cameras use Altronix model HubWayDvi Video Balun/Combiner (Figs. 2c, 2d, pg. 7).
 The total cable distance must not exceed 750 ft. for video transmission between the HubSat and each camera. Repeat this step for all other camera channels [PVD2-4].
8. Set illuminated master power disconnect circuit breaker to the RESET (ON) position (Fig. 5a, pg. 8). Power LEDs (Green) of the HubSat will illuminate when AC power is present (Fig. 1e, pg. 6) and HubWayAv, HubWayDv or HubWayDvi Video Balun/Combiner LEDs will illuminate indicating power is present (Fig. 2b, 2d, pg. 7).
9. Measure the output voltage at each Video Balun/Combiner (Figs. 2b, 2d, pg. 7) before making connections to each camera to ensure proper operation and avoid possible damage.
10. Set illuminated master power disconnect circuit breaker to the [OFF] position (Fig. 5a, pg. 8).
11. Connect power outputs of HubWayAv, HubWayAv2, HubWayDv or HubWayDvi Video Balun/Combiners to power inputs of cameras (Figs. 2a-2e, pg. 7). Polarity must be observed.
 - HubWayAv/HubWayAv2 - Terminals marked [AC POWER] (Figs. 2a, 2b, 2e, pg. 7).
 - HubWayDv/HubWayDvi - Terminals marked [- 12VDC +] (Figs. 2c, 2d, pg. 7).
12. Connect the terminals marked [+ DATA -] of HubWayAv, HubWayAv2, HubWayDv or HubWayDvi Video Balun/Combiners to data input terminals of cameras for PTZ control (Figs. 2b-2d, pg. 7). Polarity must be observed. When using fixed cameras disregard this step.
13. Connect the BNC connector of HubWayAv, HubWayAv2, HubWayDv or HubWayDvi Video Balun/Combiners to the BNC video outputs of cameras (Figs. 2b-2d, pg. 7).
14. Set illuminated master power disconnect circuit breaker to the RESET (ON) position (Fig. 5a, pg. 8).
15. The power LEDs (Green) of the HubSat will illuminate when AC power is present (Fig. 1e, pg. 6).

Note: If any of the power LEDs are not illuminated the cause may be due to the following:

- a. AC mains fail.
- b. Illuminated master power disconnect circuit breaker is tripped.
- c. Primary in-line fuse is blown.

Note: Replace fuse with same type and rating:

Primary in-line fuse is rated @ 3.5A/250V (Fig. 5b, pg. 8).

- d. An individual power output voltage switch is set to the [OFF] position (Fig. 1d, pg. 6).
- e. A PTC is tripped due to a short circuit or overload condition for one or more channels/power outputs. To reset the PTC:
 1. Set the voltage output selector switch for that corresponding channel to the OFF position. Switch must remain in the OFF position for approximately 2 minutes in order for the PTC to reset (Fig. 1d, pg. 6).
 2. Eliminate the trouble condition (short circuit or overload).
 3. Set the voltage output selector switch for either 24VAC or 28VAC (Fig. 1d, pg. 6).



Primary In-line Fuse

HubSat4D for Use as a Remote Accessory Module with HubWay/HubWayLD/HubWayLDH UTP Transceiver Hubs.

After completing steps 1-4 of Installation Instructions HubSat4D Passive UTP Transceiver Hub with Integral Camera Power proceed with the following.

1. For fixed cameras run a single CAT-5 cable between HubSat and HubWay, HubWayLD or HubWayLDH to allow video transmission of up to four (4) cameras. For PTZs run two (2) CAT-5 cables between HubSat and HubWay, HubWayLD or HubWayLDH (Fig. 7, pg. 9).
 - a. Connect one (1) of the CAT-5 cables to the RJ45 jack marked [Video 1-4] on HubSat. Connect the opposite end of this CAT-5 cable into the RJ45 jack marked [CH 1-4] of HubWay, HubWayLD or HubWayLDH unit (Fig. 7, pg. 9).
 - b. For data (PTZ) connect the second CAT-5 cable to the RJ45 jack marked [Data 1-4] on HubSat. Connect the opposite end of this CAT-5 cable into any unused RJ45 jack marked [1-16] of HubWay, HubWayLD or HubWayLDH unit (Fig. 7, pg. 9).

Note: Data inputs of HubWay, HubWayLD or HubWayLDH units must be wired in parallel for proper operation. When using fixed cameras disregard this step.

2. Plug the RJ45 connector at one end of the CAT-5 or higher structured cable into the RJ45 jack marked [PVD1] on HubSat (Fig. 1i, pg. 4). Plug the RJ45 connector at the opposite end of the CAT-5 or higher structured cable into the RJ45 jack of the Video Balun/Combiner to be installed at camera 1.
 - For 24VAC cameras use Altronix model HubWayAv/HubWayAv2 Video Balun/Combiner (Figs. 2a, 2b, 2e, pg. 7).
 - For 12VDC cameras use Altronix model HubWayDv Video Balun/Combiner (Figs. 2c, 2d, pg. 7).
 - For non-isolated 12VDC cameras use Altronix model HubWayDvi Video Balun/Combiner (Figs. 2c, 2d, pg. 7).

The total cable distance must not exceed 750 ft. for video transmission between the HubSat8D and each camera. Repeat this step for all other camera channels [PVD2-4].

3. Set illuminated master power disconnect circuit breaker to the RESET (ON) position (Fig. 5a, pg. 8) power LEDs (Green) of the HubSat will illuminate when AC power is present (Fig. 1e, pg. 4) and HubWayAv, HubWayDv or HubWayDvi Video Balun/Combiner LEDs will illuminate indicating power is present (Fig. 2b, 2d, pg. 7).
4. Measure the output voltage at each Video Balun/Combiner (Figs. 2b, 2d, pg. 7) before making connections to each camera to insure proper operation and avoid possible damage.
5. Set illuminated master power disconnect circuit breaker to the (OFF) position (Fig. 5a, pg. 8).
6. Connect power outputs of HubWayAv, HubWayAv2, HubWayDv or HubWayDvi Video Balun/Combiners to power inputs of cameras (Figs. 2a-2e, pg. 7). Polarity must be observed.
 - HubWayAv/HubWayAv2 - Terminals marked [AC POWER] (Figs. 2a, 2b, 2e, pg. 7).
 - HubWayDv/HubWayDvi - Terminals marked [- 12VDC +] (Figs. 2c, 2d, pg. 7).
7. Connect the terminals marked [+ DATA -] of HubWayAv, HubWayAv2, HubWayDv or HubWayDvi Video Balun/Combiners to data input terminals of cameras for PTZ control (Figs. 2b-2d, pg. 7). Polarity must be observed. When using fixed cameras disregard this step.
8. Connect the BNC connector of HubWayAv, HubWayAv2, HubWayDv or HubWayDvi Video Balun/Combiners to the BNC video outputs of cameras (Figs. 2a-2e, pg. 7).
9. Set illuminated master power disconnect circuit breaker to the RESET (ON) position (Fig. 5a, pg. 8).
10. The power LEDs (Green) of the HubSat will illuminate when AC power is present (Fig. 1e, pg. 4).

Note: If any of the power LEDs are not illuminated the cause may be due to the following:

- a. AC mains fail.
- b. Illuminated master power disconnect circuit breaker is tripped.
- c. One or both primary in-line fuse(s) are blown.



Primary In-line Fuse

Note: Replace fuse with same type and rating:

Primary in-line fuses are rated @ 3.5A/250V (Fig. 5b, pg. 8).

- d. An individual power output voltage switch is set to the OFF position (Fig. 1d, pg. 4).
- e. A PTC is tripped due to a short circuit or overload condition for one or more channels/power outputs. To reset the PTC:
 1. Set the voltage output selector switch for that corresponding channel to the OFF position. Switch must remain in the OFF position for approximately 2 minutes in order for the PTC to reset (Fig. 1d, pg. 4).
 2. Eliminate the trouble condition (short circuit or overload).
 3. Set the voltage output selector switch for either 24VAC or 28VAC (Fig. 1d, pg. 4).

Alternate 24VAC Fixed Camera Hookup (Fig. 7a, pg. 9).

After completing steps 1-5 of Installation Instructions Remote Accessory Module for use with HubWay, HubWayLD or HubWayLDH UTP Transceiver Hubs proceed with the following.

1. Set illuminated master power disconnect circuit breaker to the (OFF) position (Fig. 5a, pg. 8).
2. Connect one end of the coaxial cable to the BNC connector marked [Video1] on HubSat (Fig. 1a, pg. 4). Connect the opposite end of the coaxial cable to the BNC video output of camera 1 (Fig. 7a, pg. 9).
3. Set illuminated master power disconnect circuit breaker to the RESET (ON) position (Fig. 5a, pg. 8). Measure the output voltage at terminal pair marked [AUX1] on HubSat to insure proper operation and avoid possible damage (Fig. 1b, pg. 4).
4. Connect the power output terminal pair marked [AUX1] on HubSat to the power inputs of camera 1 (Fig. 1c, pg. 4). Repeat steps 1-3 for each additional camera [AUX2-4].

Fig. 1 - HubSat Circuit Board

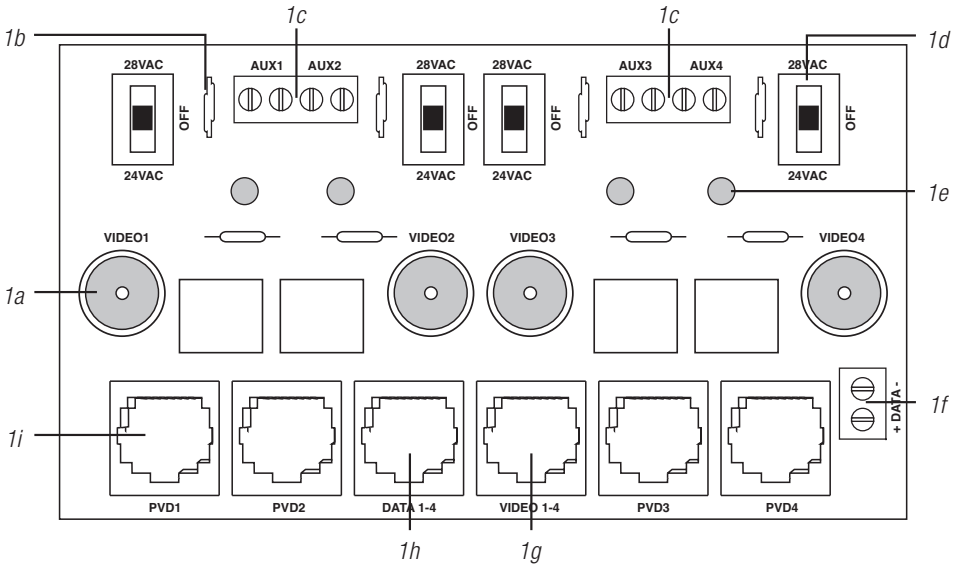

1a - **BNC Connector:** Video in from remote camera video out to DVR.

1b - **Output PTCs:** Protects each output.

1c - **Power Terminals:** 24VAC/28VAC power outputs.

1d - **Output Voltage Switches:** Selects 24VAC/28VAC/OFF for each output.

1e - **LED(s) 1-4:** Power output indicators.

1f - **Data:** RS422/RS485 input from head end equipment (DVR) for PTZ control.

1g - **Channels 1-4:** Single CAT-5 or higher structured cable out to HubWay, HubWayLD or HubWayLDH enables transmission of up to four (4) video signals.

Pin out configuration (Fig. 4, pg. 7).

1h - **Data:** CAT-5 or higher structured cable to data port on HubWay, HubWayLD or HubWayLDH or head end equipment (DVR).

1i - **Channels 1-4:** CAT-5 or higher structured cable to cameras. Pin out configuration (Fig. 3, pg. 7).

HubWayAv, HubWayAv2, HubWayDv, and HubWayDvi Video Balun/Combiners:

Altronix Model Number	Input Voltage from HubWay Unit	Output Voltage to Camera	Camera Type	Power LED
HubWayAv	*24VAC/28VAC	*24VAC/28VAC	*24VAC/28VAC	Green
HubWayAv2	*24VAC/28VAC	*24VAC/28VAC	*24VAC/28VAC	N/A
HubWayDv	*24VAC/28VAC	12VDC	12VDC cameras	Red
HubWayDvi	*24VAC/28VAC	12VDC electronically isolated	12VDC cameras without isolation	Red

*Based on camera load and structured cable length.

Fig. 2

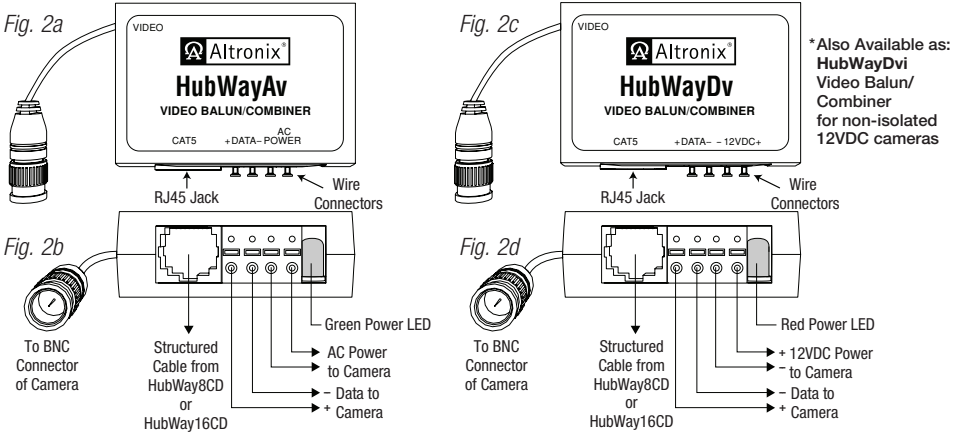
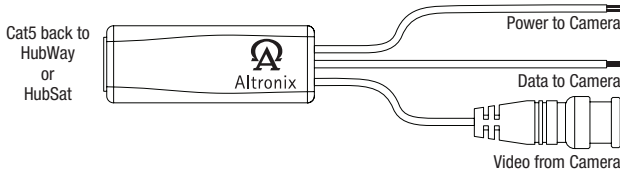

Fig. 2e - HubWayAV2



HubWayAv/HubWayAv2 passes AC voltage from pins 4, 5, 7, 8 to terminals marked [AC Power] (Fig. 3, pg. 7).

HubWayDv/HubWayDvi converts AC voltage to DC voltage from pins 4, 5, 7, 8 to terminals marked [- 12VDC +] (Fig. 3, pg. 7).

Fig. 3 - CAT-5 Structured Cable Wiring Color Codes and PIN Configurations PVD1-4 on HubSat4D and Video Balun/Combiner

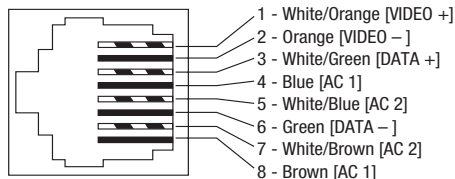

Fig. 4 - CAT-5 Structured Cable Wiring Color Codes for Video 1-4 Port on HubSat4D board

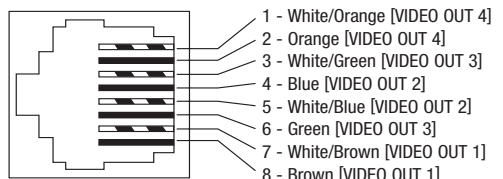

Fig. 5

Fig. 5a - Illuminated master power disconnect circuit breaker:

- OFF position: circuit breaker tripped – Switch not illuminated.
- RESET (ON) position – Switch illuminated.

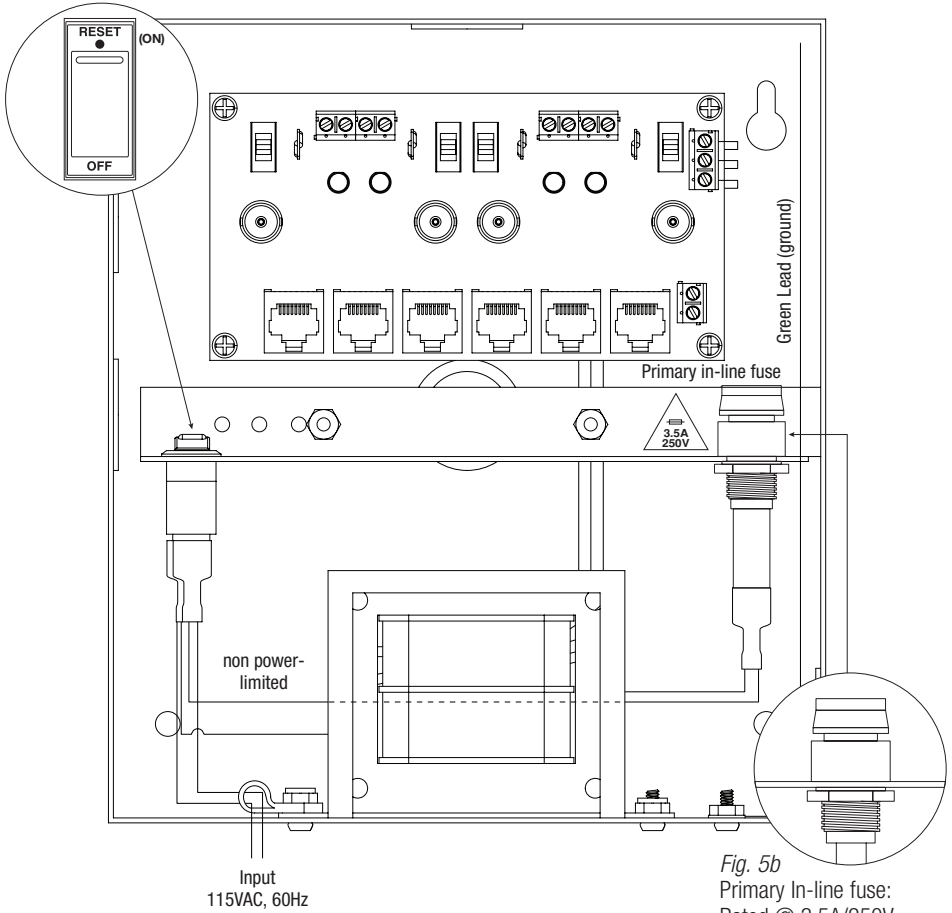
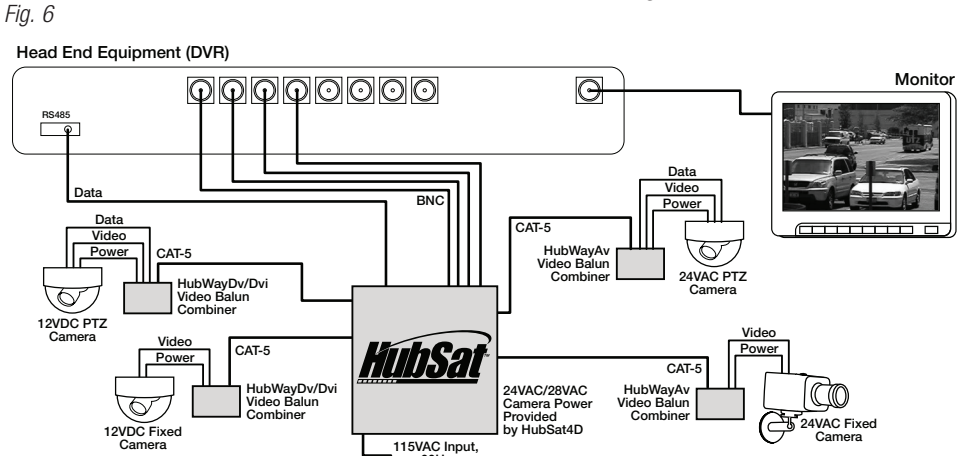

Fig. 5b
Primary In-line fuse:
Rated @ 3.5A/250V

Typical Application Drawing

HubSat4D Passive UTP Transceiver Hub with Integral Camera Power:



Typical Application Drawing

HubSat4D Remote Accessory Module with HubWay UTP Transceiver Hubs:

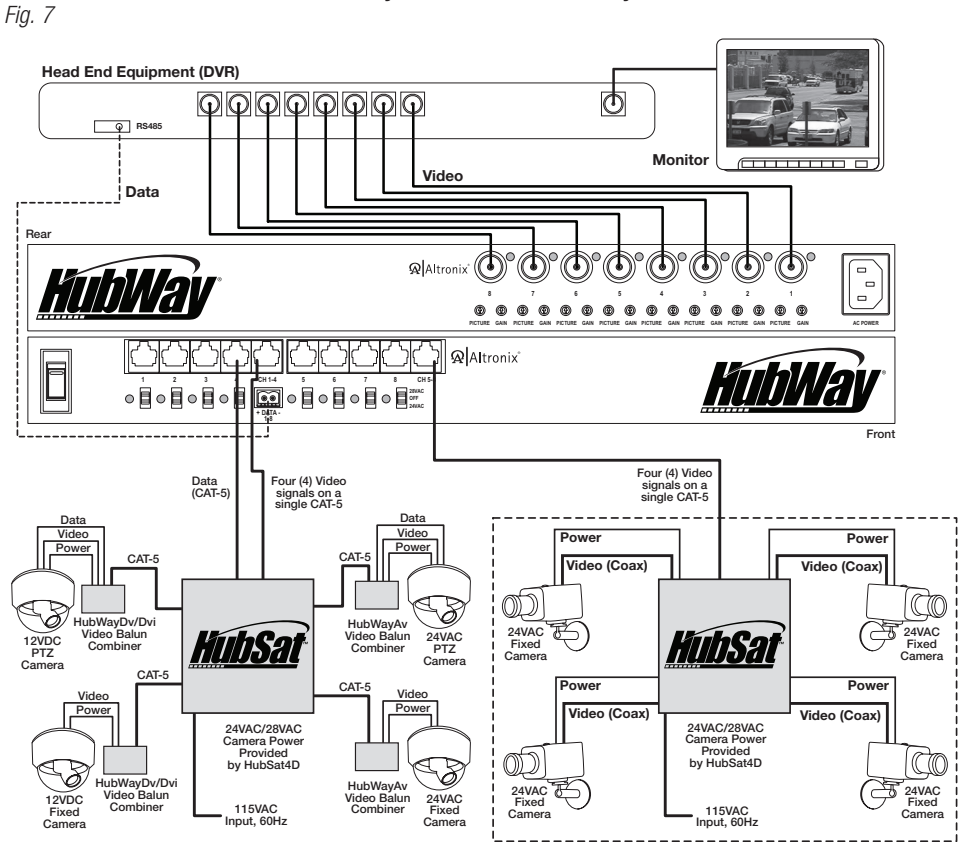

Fig. 7a - Alternate 24VAC fixed camera hookup.

Notes:

Notes:



The lightning flash with arrowhead symbol within an equilateral triangle is intended to alert the user to the presence of an insulated DANGEROUS VOLTAGE within the product's enclosure that may be of sufficient magnitude to constitute an electric shock.



The exclamation point within an equilateral triangle is intended to alert the user to the presence of important operating and maintenance (servicing) instructions in the literature accompanying the appliance.



CAUTION
RISK OF ELECTRIC SHOCK
DO NOT OPEN



CAUTION: To reduce the risk of electric shock do not open enclosure. There are no user serviceable parts inside. Refer servicing to qualified service personnel.

Enclosure Dimensions (H x W x D approximate):

8.5" x 7.5" x 3.5" (215.9mm x 190.5mm x 88.9mm)

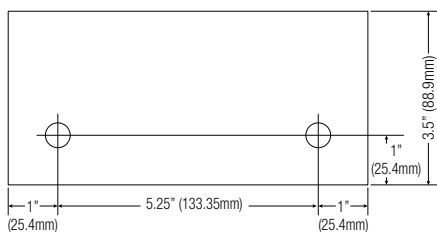
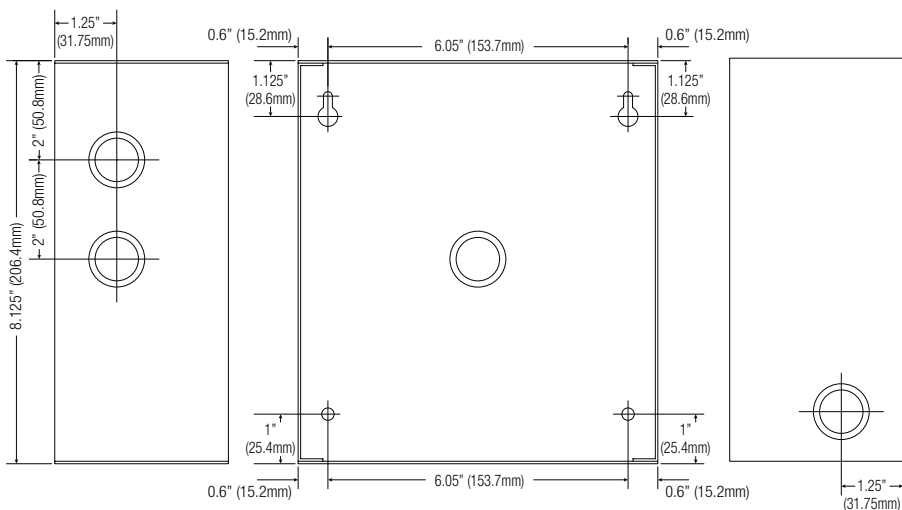
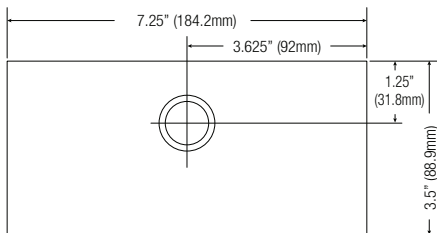

Altronix is not responsible for any typographical errors.

140 58th Street, Brooklyn, New York 11220 USA | phone: 718-567-8181 | fax: 718-567-9056
website: www.altronix.com | e-mail: info@altronix.com | Lifetime Warranty
IH-HubSat4D 120U



MEMBER