

GV-SR1352 Card Reader

The content of this installation guide refers to GV-SR1352.

Introduction

GV-SR1352 is a dual-band RFID card reader that recognizes access control cards. Featured with Wiegand outputs, GV-SR1352 can be connected to any Wiegand-compatible access control systems. Its dual-band capability offers great flexibility for integrators to solve card management issues on the locations, installed with both 125 kHz EM and 13.56 MHz readers. For outdoor use, GV-SR1352 comes with a weather-sealed and IP66-compliant housing.

Specification

Power Source	DC 9 ~ 24 V
Power Consumption	25 mA (max)
RFID Frequency	125 kHz and 13.56 MHz
Reading Range	1 – 3 cm (0.3 – 2.3 in)
Wiegand Interface	Wiegand 26 bits for EM, 26 / 34 bits for Mifare
Operating Temperature	-20 °C ~ 60 °C (-4 °F ~ 140 °F)
Operating Humidity	10% to 95% RH
Color	Black
Ingress Protection	IP66
Dimensions (H x W x T)	103 x 47.86 x 20 mm (4.06" x 1.89" x 0.79")
Weight	150 g (0.33 lb)

Installation

1. Drill 2 holes (A, C) on the wall for the screws and one hole for the cable.
2. Knock the plastic screw anchors to the holes (A, C).
3. Fix the back cover on the wall with 2 screws.
4. Thread the cable through the cable hole (B).
5. Attach the unit to the back cover.

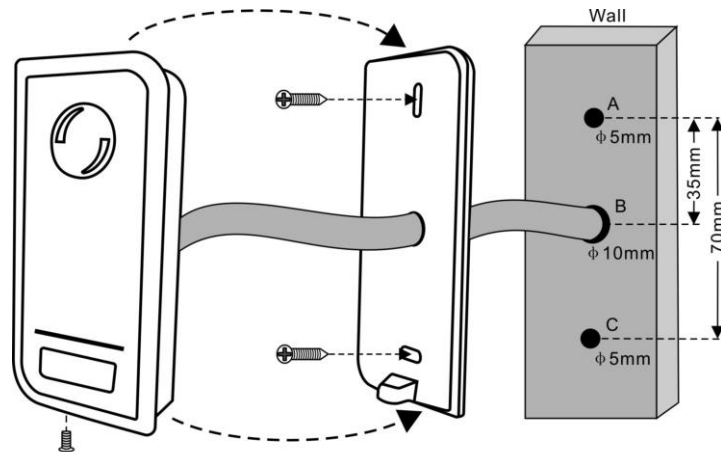

Electric Wire

Wire Color	Function	Notes
Red	Power +	+ DC (9-24V DC)
Black	GND	Ground
Green	D0	Data 0
White	D1	Data 1
Brown	LED	Green LED Light Control
Yellow	Buzzer	Buzzer Control

Note: Brown and yellow wires are optional connections.

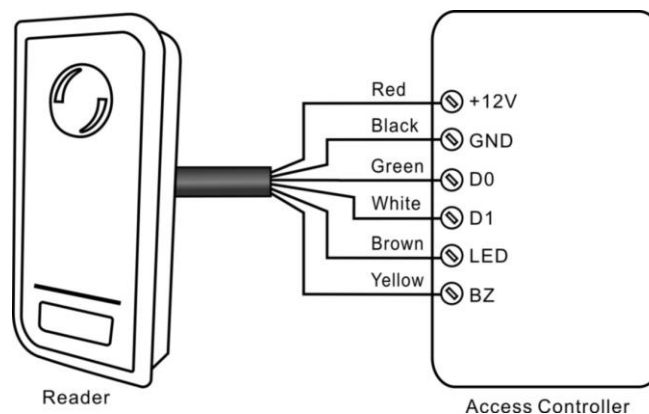

Function

Read Card	The LED light turns Green, and the buzzer beeps while the reader outputs the Wiegand signal.
External LED Control	When the input voltage for LED is low, the LED turns Green.
External Buzzer Control	When the input voltage for Buzzer is low, the Buzzer beeps.
Wiegand Data Output	Wiegand 26/34 bits range available for the reader, EM and Mifare cards are forced to output based on the reader setting.

Data Signal

Pulse Times	
Description	Reader Typical Time
Pulse Width Time	42 μ S
Pulse Interval Time	2 mS

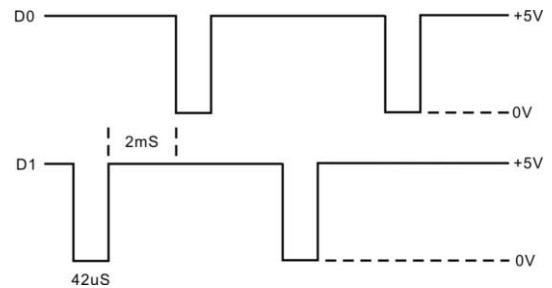

The above table shows the wave form of pulse width time (the duration of a pulse) and pulse interval time (the time between pulses) of the Wiegand data output from the readers.

(Example 1010)

Packing List

1. GV-SR1352
2. Screw driver
3. Screw x 2
4. Plastic Screw Anchor x 2
5. Installation Guide