

GV-Card Reader

User's Manual



Before attempting to connect or operate this product, please read these instructions carefully and save this manual for future use.

© 2023 GeoVision, Inc. All rights reserved.

Under the copyright laws, this manual may not be copied, in whole or in part, without the written consent of GeoVision.

Every effort has been made to ensure that the information in this manual is accurate. GeoVision, Inc. makes no expressed or implied warranty of any kind and assumes no responsibility for errors or omissions. No liability is assumed for incidental or consequential damages arising from the use of the information or products contained herein. Features and specifications are subject to change without notice.

GeoVision, Inc.
9F, No. 246, Sec. 1, Neihu Rd.,
Neihu District, Taipei, Taiwan
Tel: +886-2-8797-8377
Fax: +886-2-8797-8335
<http://www.geovision.com.tw>

Trademarks used in this manual: GeoVision, the GeoVision logo and GV series products are trademarks of GeoVision, Inc. Windows is the registered trademark of Microsoft Corporation. MIFARE and DESFire are registered trademarks of NXP B.V.

July 2023

Scan the following QR codes for product warranty and technical support policy:



[Warranty]



[Technical Support Policy]

Notice

Notice for GV-R1352 V2B and GV-R1352 V2C: This device complies with Part 15 of the FCC Rules. Operation is subject to the following two conditions: (1) This device may not cause harmful interference, and (2) This device must accept any interference received, including interference that may cause undesired operation.

Notice for GV-RKD1352

Federal Communication Commission Interference Statement

This equipment has been tested and found to comply with the limits for a Class B digital device, pursuant to Part 15 of the FCC Rules. These limits are designed to provide reasonable protection against harmful interference in a residential installation.

This equipment generates, uses and can radiate radio frequency energy and, if not installed and used in accordance with the instructions, may cause harmful interference to radio communications. However, there is no guarantee that interference will not occur in a particular installation. If this equipment does cause harmful interference to radio or television reception, which can be determined by turning the equipment off and on, the user is encouraged to try to correct the interference by one of the following measures:

- Reorient or relocate the receiving antenna.
- Increase the separation between the equipment and receiver.
- Connect the equipment into an outlet on a circuit different from that to which the receiver is connected.
- Consult the dealer or an experienced radio/TV technician for help.

FCC Caution: To assure continued compliance, any changes or modifications not expressly approved by the party responsible for compliance could void the user's authority to operate this equipment. (Example - use only shielded interface cables when connecting to computer or peripheral devices).

Preface

Welcome to the *GV-Card Reader User's Manual*.

This Manual applies to the following GV-Card Readers:

Reader Models
GV-Reader1251 and 1352 V2
GV-SR1251
GV-RK1352 / R1352
GV-DFR1352 (Rev. B)
GV-DFK1355
GV-RKD1352
GV-R1355
GV-RKR1355
GV-RKV1355
GV-R1354

Some GV reader models support MIFARE® DESFire®, MIFARE Plus® and MIFARE Classic® access cards and tags. For details, you may refer to the product's datasheet.

Naming and Definition

Name	Description
UID	A type of card number; stands for Unique Identifier.
GID	A type of card number; stands for GeoVision Identifier.
DES-ID	A type of card number used for MIFARE® DESFire® cards.

Note for Waterproofing

To prevent water from penetrating the reader from the rear panel, use the following waterproofing measures when installing GV-DFK1355, GV-RKV1355, GV-RKR1355, or GV-RKD1352.

1. The rear panel of GV-DFK1355 or GV-RKV1355 has waterproofing rubber rings. Install the reader tightly against the wall to prevent water from entering along the wall. Apply silicone sealant to the sides of the reader if it is mounted on an uneven surface.
2. Apply silicone sealant to the sides of GV-RKR1355 or GV-RKD1352 readers to prevent water from entering along the wall.



(X) A gap between the wall and the reader



(O) The reader against the wall

Contents

Notice	ii
Preface	iii
Naming and Definition	iii
Note for Waterproofing	iv
Contents	v
Chapter 1 GV-Reader1251 / 1352 V2 and GV-SR1251	1
1.1 Packing List.....	1
1.2 Installation	2
1.2.1 Electric Wire	2
1.2.2 Switch Settings of GV-Reader1251 / 1352 V2	2
1.2.3 Define the ID of GV-SR1251	4
1.3 Connect the Reader to GV-AS Controller	5
1.3.1 Connect through Wiegand Interface	5
1.3.2 Connect through RS-485 Interface	6
1.3.3 Connect to GV-DVR/NVR and Third-Party Controllers	8
1.4 Overlay Card Numbers on GV-DVR/NVR Live View.....	9
1.5 Control the Beeper and LED.....	10
1.6 Specifications	11
Chapter 2 GV-RK1352 / R1352 / DFR1352	12
2.1 Packing List.....	13
2.2 Physical Descriptions	14
2.2.1 Electric Wire	14
2.2.2 Keypad (GV-RK1352 Only)	16
2.2.3 LED and Beeper.....	16

2.3	Connect the Reader to GV-AS Controller	17
2.3.1	Connect through Wiegand Interface	17
2.3.2	Connect through RS-485 Interface	18
2.3.3	Define Readers on GV-AS Controller Web Interface	19
2.4	Install GV-R/RK/DFR Setup AP	21
2.5	Overlay Card Numbers on GV-DVR/NVR Live View	22
2.5.1	Define the ID and Set the Reader to Slave	23
2.5.2	Add the Reader to GV-DVR/NVR	25
2.6	Control the Beeper and LED.....	26
2.6.1	Enable External Control on the Reader	26
2.6.2	Connect the Beeper and LED.....	28
2.6.3	Set the Beeper and LED for Each Door/Gate	29
2.7	Configure Card Identifier	30
2.8	Firmware Upgrade.....	32
2.9	Specifications	33
2.10	Accessory (GV-RK1352 and GV-R1352 Only).....	34
Chapter 3 GV-RKD1352.....		35
3.1	Packing List.....	35
3.2	Compatible Products	35
3.3	Physical Descriptions	36
3.4	Installation	38
3.5	Keypad.....	39
3.6	LED Status and Beeper.....	39
3.7	Firmware Upgrade.....	40
3.8	Specifications	41
Chapter 4 GV-R1355.....		42
4.1	Packing List.....	42
4.2	Compatible Products	42

4.3 Physical Descriptions	43
4.5 LED Status and Beeper	46
4.6 Firmware Upgrade.....	46
4.7 Specifications	46
Chapter 5 GV-RKR1355.....	47
5.1 Packing List.....	47
5.2 Compatible Products	47
5.3 Physical Descriptions	48
5.4 Installation	50
5.5 Keypad.....	51
5.6 LED Status and Beeper.....	51
5.7 Firmware Upgrade.....	52
5.8 Specifications	52
Chapter 6 GV-RKV1355.....	53
6.1 Packing List.....	53
6.2 Compatible Products	53
6.3 Physical Descriptions	54
6.4 Installation	56
6.5 Keypad.....	57
6.6 LED Status and Beeper.....	57
6.7 Firmware Upgrade.....	57
6.8 Specifications	57
Chapter 7 GV-R1354.....	58
7.1 Packing List.....	58
7.2 Compatible Products	58

7.3 Physical Descriptions	59
7.4 Installation	60
7.5 ID, Beeper and LED Settings.....	60
7.6 Firmware Upgrade.....	62
7.7 Specifications	63
Chapter 8 GV-DFK1355.....	64
8.1 Packing List.....	64
8.2 Compatible Products	64
8.3 Physical Descriptions	65
8.4 Installation	67
8.5 Keypad.....	68
8.6 LED Status and Beeper	68
8.7 ID and Card Identifier Settings.....	68
8.8 GV-Cloud Access Control Integration	70
8.9 Firmware Upgrade.....	72
8.10 Specifications	72
Appendix	73
What to do if RS-485 connection fails?.....	73

Chapter 1 GV-Reader1251 / 1352 V2 and GV-SR1251

GV-Reader1251 / 1352 V2 / SR1251 includes transmit-receive antenna and electronics. It has both Wiegand and RS-485 outputs that can be connected to any standard access control panel. The LED indicator is controllable by the host system and changes from red to green to indicate access granted. GV-Reader1251 / 1352 V2 / SR1251 also has a host-controllable buzzer.

1.1 Packing List

If any of the items are missing or damaged, contact your dealer to arrange a replacement.

For GV-Reader 121 / 1352 V2

1. GV-Reader1251 / 1352 V2
2. Bag of screws
3. GV-Reader Software CD
4. Warranty Card

For GV-SR1251

1. GV-SR1251
2. Screw x 6
3. Plastic Screw Anchor x 4
4. Plastic Case
5. Warranty Card

1.2 Installation

1.2.1 Electric Wire

Wire Color	Function
Red	DC 7.5 ~ 12 V
Black	GND
Green	Wiegand Data 0
White	Wiegand Data 1
Blue	RS-485 +
Light Blue	RS-485 -
Yellow	Beeper
Orange	Green LED
Light Red	Red LED

1.2.2 Switch Settings of GV-Reader1251 / 1352 V2

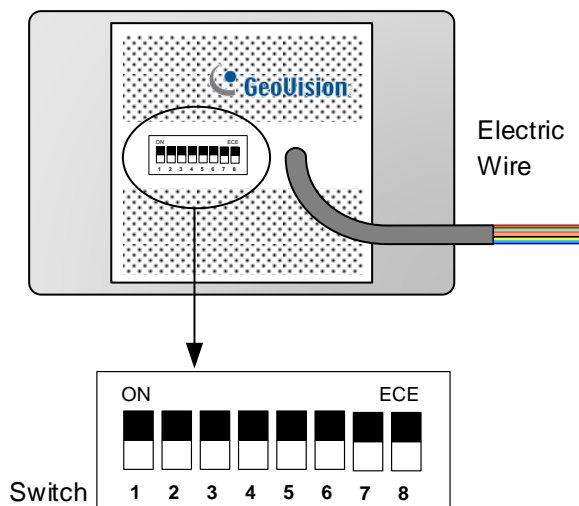

Default settings are all ON.

- SW 1 Beeper Control:** The default mode for the Beeper Control is the internal control. When the setting is “On”, the Reader is sounded after a card is read. When the setting is “Off”, the Beeper is controlled externally. You can use the external beeper control line to activate the beeper.

- **SW2-SW3 Green/Red LED Control:** The default mode for the Green/Red LED Control is the internal control. The LED is normally red. When a card is read, the LED flashes green. When the setting is “Off”, the Green/Red LED is controlled externally. The external control lines can then be used to operate the LEDs.
- **SW4 Master/Slave:** The switch is used to select the Reader’s communication interface. When the setting is “On”, the Reader is controlled by Wiegand signal. When the setting is “Off”, the Reader is for RS-485 signal.
- **SW5-SW7 ID Setting:** Switch 5 to switch 7 is used to set the Reader’s ID for wiring in a daisy chain.

ID	0	1	2	3	4	5	6	7
SW5	OFF	OFF	OFF	OFF	ON	ON	ON	ON
SW6	OFF	OFF	ON	ON	OFF	OFF	ON	ON
SW7	OFF	ON	OFF	ON	OFF	ON	OFF	ON

- **SW8 RS-485 Terminal Resistor:** When the setting is “On,” a 120-ohm resistor is connected between RS-485+ and RS-485-. This setting is used in the last device when multiple RS-485 devices are connected together.

Note: After changing the dip switch settings, the unit must be reset by powering down then up again before the new switch setting will take effect.

1.2.3 Define the ID of GV-SR1251

Up to 8 readers can be connected to GV-AS Controller via a single RS-485 interface. To create a daisy chain connection, use the Setup AP to define each reader's ID number.

1. Install and download the Setup AP. For details, see *2.4 Install GV-R/RK/DFR Setup AP*.
2. Run **GV-R/RK/DFR Setup AP**.

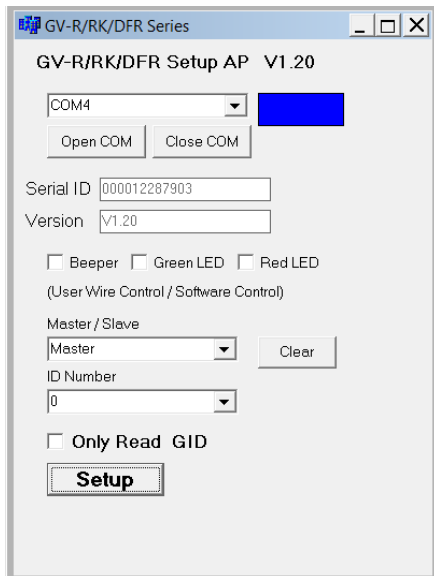

3. Select the COM port that is connected to the reader and click **Open COM**. The red square next to the COM port box should change to blue to indicate the COM port is correct.
4. Select an **ID number** for the reader. The ID number ranges from 0 to 7.
5. Click **Setup**. The serial number and firmware version of the reader are automatically detected. The settings are sent to the reader.

Note:

1. To define the ID number of GV-Reader1251 / 1352 V2, use the switches at the back of the reader.
 2. GV-SR1251 only reads UID (Unique Identifier). Therefore, the **Only Read GID** option in the GV-R/RK/DFR Setup AP is not functional for GV-SR1251.
-

1.3 Connect the Reader to GV-AS Controller

GV-Reader1251 / 1352 V2 / SR1251 is compatible with any standard access controllers. The following diagrams illustrate how to connect GV-Reader1251 / 1352 V2 / SR1251 to GV-AS Controller through Wiegand or RS-485 interface, and how to connect GV-Reader1251 / 1352 V2 / SR1251 to third-party access controllers and GV-DVR/NVR.

For GV-Reader1251 / 1352 V2, after you wire the connection between the reader and the access controller, ensure that related switch settings on GV-Reader1251 / 1352 V2 are configured correctly.

Note: Each reader consumes 60 mA of power. The total power consumption of the output devices and readers connected to GV-AS Controller must be under **2.5A** (for GV-CS1320), **3A** (for GV-AS1620, GV-AS210 / 2110 / 2120), **3.5A** (for GV-AS410 / 4110) or **5A** (for GV-AS810 / 8110). Connect an external power supply if the power supplied from GV-AS Controller is insufficient.

1.3.1 Connect through Wiegand Interface



- Switch Setting for Wiegand Connection (GV-Reader1251 / 1352 V2 only)

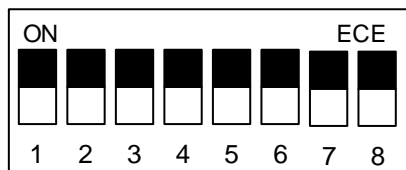

SW4 must be turned ON.

1.3.2 Connect through RS-485 Interface

Multiple readers can be connected to GV-AS Controller through a single RS-485 interface.

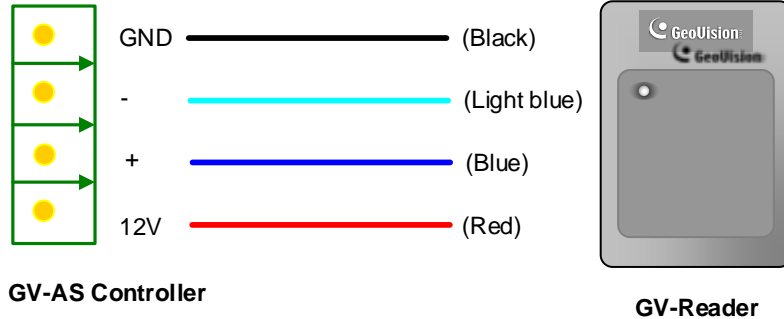

- Switch Settings for RS-485 Connection (GV-Reader1251 / 1352 V2 only)

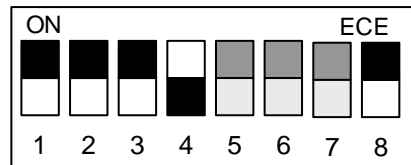

SW4 must be turned OFF.

- Switch Settings for Multiple GV-Readers (RS-485) (GV-Reader1251 / 1352 V2 only)
When connecting multiple readers to GV-AS Controller, turn **SW8** on the last connected GV-Reader to ON. Make sure to define the ID of each reader using SW5 to SW7 first.

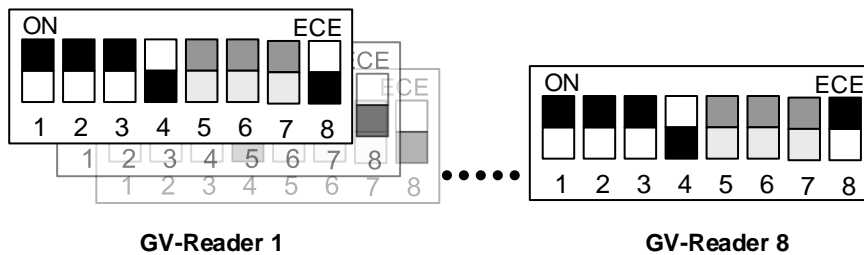

- ID Number Settings for Multiple GV-Readers (RS-485) (GV-SR1251 only)
To define the ID of each GV-SR1251, see *1.2.3 Define the ID of GV-SR1251*.

Defining Readers on GV-AS Controller Web Interface

After configuring the switch settings of GV-Reader1251 / 1352 V2 or defining the ID number of GV-SR1251 using GV-R/RK/DFR Setup AP, you need to specify which door each reader controls on the Web interface of GV-AS Controller.

1. On the controller's Web interface, select **Extended Reader**. This page appears.

AS210 Extended Reader Configuration

GV-Reader/CR420/GF1921/GF1922 Function

RS485	Serial Number	Function	Connection Status
<input checked="" type="checkbox"/>	ID 0 <input type="text"/>	Door/Gate 1 Entry ▼	
<input type="checkbox"/>	ID 1 <input type="text"/>	No Function ▼	
<input type="checkbox"/>	ID 2 <input type="text"/>	No Function ▼	
<input type="checkbox"/>	ID 3 <input type="text"/>	No Function ▼	
<input type="checkbox"/>	ID 4 <input type="text"/>	No Function ▼	
<input type="checkbox"/>	ID 5 <input type="text"/>	No Function ▼	
<input type="checkbox"/>	ID 6 <input type="text"/>	No Function ▼	
<input type="checkbox"/>	ID 7 <input type="text"/>	No Function ▼	

GeoFinger Server IP Address: . . . : (from 1025 to 65535)

GF1901/GF1902/GF1911/GF1912 Function

RS485	Serial Number	Function	Connection Status
<input type="checkbox"/>	<input type="text"/>	No Function ▼	
<input type="checkbox"/>	<input type="text"/>	No Function ▼	

2. If the readers are connected using RS-485, select the **RS485** checkbox in front of the ID number. The ID number must match the ID you configured using SW5 – SW7 (for GV-Reader1251 / 1352 V2) or GV-R/RK/DFR Setup AP (for GV-SR1251).
3. Leave the serial number field blank.
4. Select a door/gate for the reader under **Function**. Click **Submit**.

1.3.3 Connect to GV-DVR/NVR and Third-Party Controllers

GV-Reader1251 / 1352 V2 / SR1251 is compatible with third-party access controllers. With its compatibility, you can also add a GV-DVR/NVR to this connection to empower your management.

After connecting GV-Reader1251 / 1352 V2 / SR1251 to the access controller through the Wiegand interface, connect the reader to GV-DVR/NVR via GV-COM, GV-Hub or GV-NET/IO Card V3.1.

Note: GV-Reader1251 / 1352 V2 / SR1251 is not compatible with the GV-NET Card and the GV-NET/IO Card of versions earlier than V3.

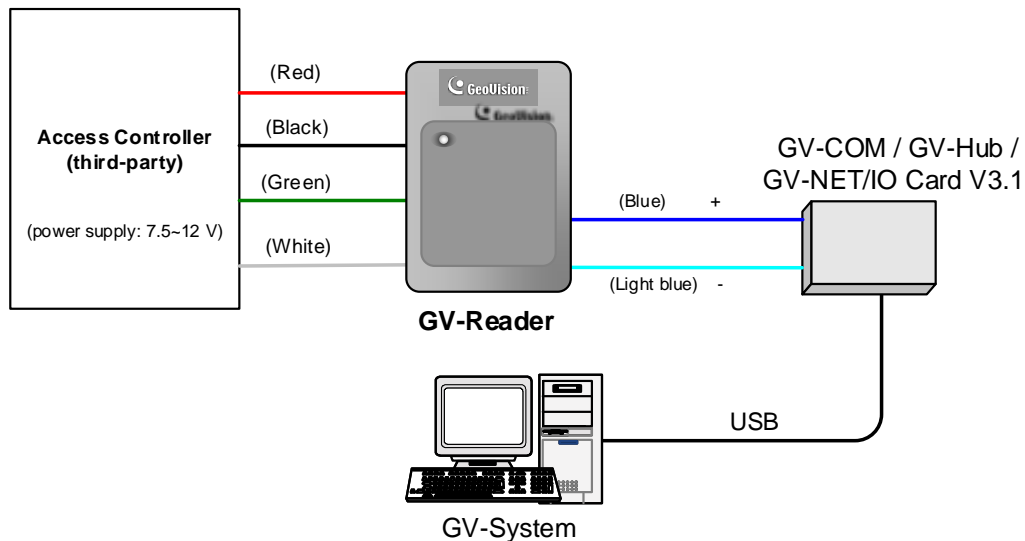

- Switch Setting (GV-Reader1251 / 1352 V2 only)

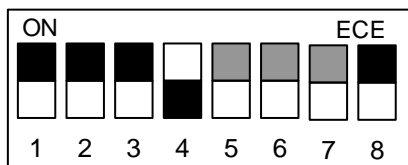

SW4 must be turned OFF.

1.4 Overlay Card Numbers on GV-DVR/NVR Live View

You can overlay card numbers recognized at GV-Reader1251 / 1352 V2 / SR1251 onto a camera channel on GV-DVR/NVR. To overlay card numbers on GV-DVR/NVR channels, connect the reader to GV-DVR/NVR through a RS-485 / USB converter (e.g. GV-COM, GV-Hub or GV-NET/IO Card V3.1) as illustrated below. For details, see *2.5 Overlay Card Numbers on GV-DVR/NVR Live View*.

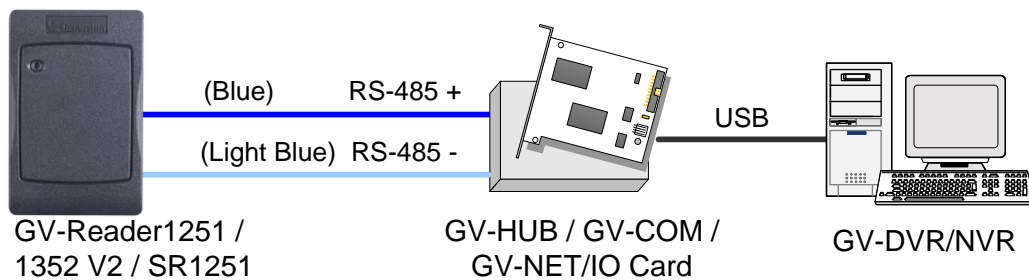

Note:

1. For GV-Reader1251 / 1352 V2, you need to define the ID number and set the reader to slave by configuring the switch settings. For details, see *1.2.2 Switch Settings of GV-Reader1251 / 1352 V2*.
 2. For GV-SR1251, you need to define the ID number and set the reader to Slave using GV-R/RK/DFR Setup AP. For details, see *2.5.1 Define the ID and Set the Reader to Slave*.
-

1.5 Control the Beeper and LED

You can configure GV-AS Controller (AS210 / 2110 / 2120 / 410 / 4110 / 810 / 8110) to control the reader's beeper or LED externally. Through the controller's Web interface, you can configure the controller to activate the reader's red LED, green LED, or beeper in response to a specific alert event.

1. For GV-SR1251, enable external controls of the reader's beeper and LED by using the **GV-R/RK/DFR Setup AP**. For details, see *2.6.1 Enable External Control on the Reader*.
2. For GV-Reader1251 / 1352 V2, enable external controls of the reader's beeper and LED by configuring the switch settings. For details, see *1.2.2 Switch Settings of GV-Reader1251 / 1352 V2*.
3. Wire the beeper, Red LED or Green LED from the reader to the controller. For details, see *2.6.2 Connect the Beeper and LED*.
4. Specify the beeper and LED settings for each door through the controller's Web interface. For details, see *2.6.3 Set the Beeper and LED for Each Door/Gate*.

Note: GV-AS1620 can also externally control the reader's LED and beeper for access granted and denied. For details, see *GV-AS1620 User's Manual*.

IMPORTANT: When GV-RK1352 / R1352 / DFR1352 / SR1251 is connected to a controller via an RS-485 connection, external control of the LED and beeper is not supported.

1.6 Specifications

	GV-Reader1251	GV-SR1251	GV-Reader1352 (V2)
CPU	8-bit microprocessor		
Wiegand Interface	Wiegand 26 bits, distance 30 m (98.43 ft) with GV-AS210 / 410 / 810; distance 100 m (328.1 ft) with GV-AS2110 / 2120 / 4110 / 8110, GV-AS1620		Wiegand 26 / 34 bits, distance 30 m (98.43 ft)
Power Source	DC 7.5~12V		
Power Consumption	60 mA		
LED	Red, Green LED	Red, Green, Blue LED	Red, Green LED
Audio	Buzzer		
Frequency	125 kHz		13.56 MHz ISO 14443A
RS-485	9,600 bps, distance 600 m (1968.50 ft)		
Color	Gray		
Operating Temperature	-35 °C ~ 65 °C (-31 °F ~ 149 °F)		
Operating Humidity	10 ~90% RH (non-condensing)		
Dimensions (W x H x D)	75 (W) x 115 (H) x 15 (T) mm, with enclosure 35 (T) mm 3 (W) x 4.5 (H) x 0.6 (T) in, with enclosure 1.38 (T) in		
Weight	150 g / 0.33 lb	125 g / 0.27 lb	150 g / 0.33 lb
Ingress Protection	IP54	IP66	IP54
Certification	CE, FCC, RoHS		

For the number of readers supported by a variety of GeoVision controllers, see the [compatibility table](#).

Chapter 2 GV-RK1352 / R1352 / DFR1352

Card readers GV-RK1352 / R1352 / DFR1352 are able to recognize access cards. The keypad on GV-RK1352 allows it to recognize PIN codes. GV-DFR1352 is intended for installation on the door frame.

Featured with the Wiegand and RS-485 outputs, the readers can be connected to any standard access control system. They are protected by a weather sealed and IP66 compliant housing for outdoor use.

2.1 Packing List

GV-RK1352



1. GV-RK1352 Card Reader
2. Screw x 2
3. Screw Anchor x 2
4. Front Cover Plate x 1



5. Software CD
6. Installation Guide
7. Warranty Card

GV-R1352



1. GV-R1352 Card Reader
2. Screw x 3
3. Screw Anchor x 2
4. Security Torx
5. Software CD
6. Installation Guide
7. Warranty Card

GV-DFR1352



1. GV-DFR1352 Card Reader
2. Screw x 2
3. Screw Anchor x 2
4. Front Cover Plate x 2
5. Software CD
6. Installation Guide
7. Warranty Card

2.2 Physical Descriptions

2.2.1 Electric Wire

GV-RK1352

Wire Color	Function
Red	DC 7.5 ~ 12 V
Black	GND
Yellow	Beeper
Orange	Green LED
Light Red	Red LED
Green	Wiegand Data 0
White	Wiegand Data 1
Blue	RS-485 +
Light Blue	RS-485 -

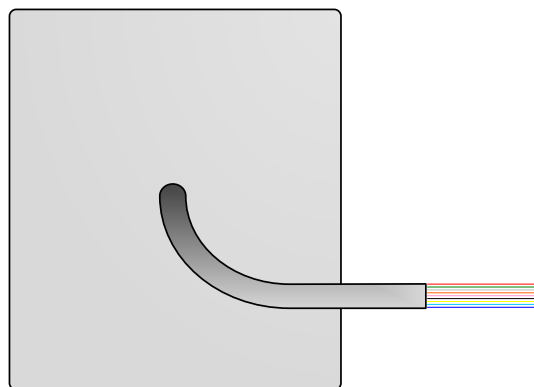

Rear View

GV-R1352

Wire Color	Function
Red	DC 7.5 ~ 12V
Black	GND
Yellow	Beeper
Orange	Green LED
Light Red	Red LED
Green	Wiegand Data 0
White	Wiegand Data 1
Blue	RS-485 +
Light Blue	RS-485 -
Gray	N/A
Purple	N/A
Brown	N/A

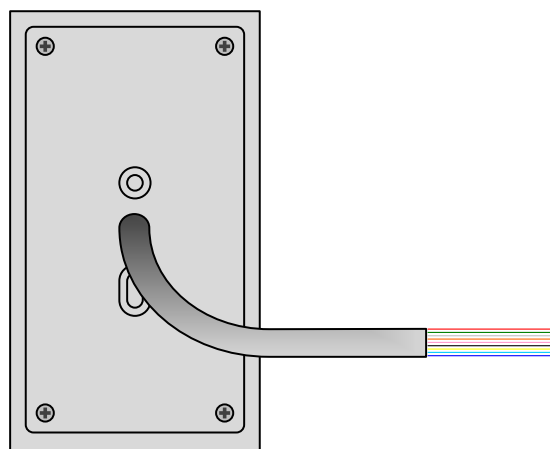

Rear View

GV-DFR1352

Wire Color	Function
Red	DC 7.5 ~ 12V
Black	GND
Yellow	Beeper
Orange	Green LED
Light Red	Red LED
Green	Wiegand Data 0
White	Wiegand Data 1
Blue	RS-485 +
Light Blue	RS-485 -
Gray	N/A
Purple	N/A
Brown	N/A

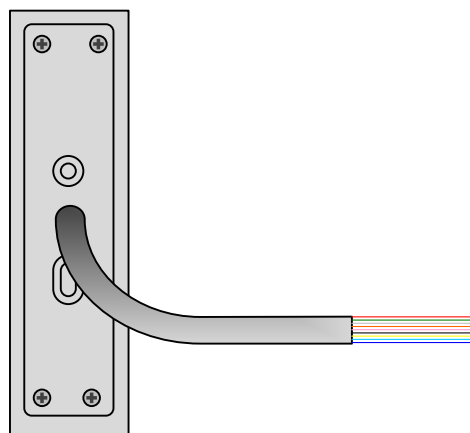

Rear View

Install the GV-DFR1352 to the door frame using the supplied screws and screw anchors. Before placing and sticking the front cover plate to the GV-DFR1352, remove the Plastic Cover to prevent scratches to the cover after installed.

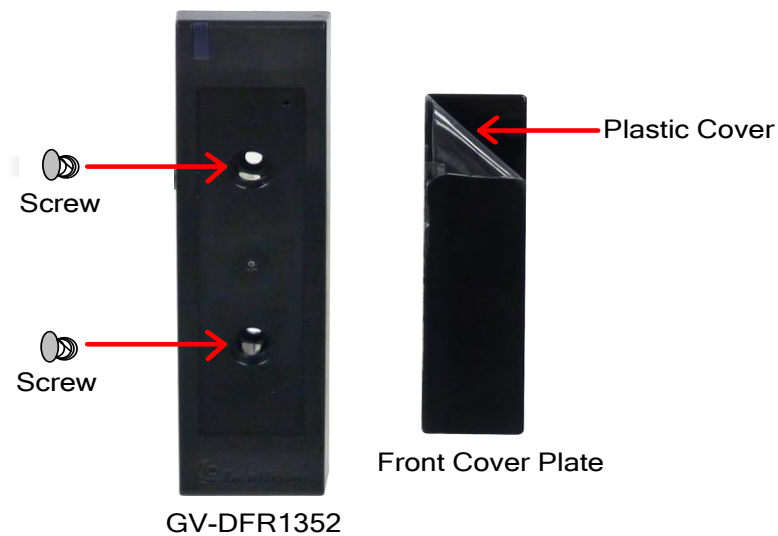

2.2.2 Keypad (GV-RK1352 Only)

When using the reader, you can enter the door's Common Password or the card's PIN code on the keypad to gain access. The access mode is set in GV-ASManager (software).

1. **0~9 Number Keys:** Press the number keys to enter a PIN or password.
2. **# Key:** Press the # key to confirm an entry.
3. *** Key:** Press the * key to cancel an entry.

IMPORTANT: The Card and PIN Code mode requires users to enter the card's PIN code, press the # key to confirm the code, and then present the card to gain access.

2.2.3 LED and Beeper

In standby mode, the LED is blue. When a card is read, the LED flashes green and the beeper beeps once.

The reader comes with external control wires for Green LED, Red LED and Beeper. You can connect these control wires to GV-AS Controller to change the default settings of the LED and beeper. For details on how to configure the settings, see *2.6 Control the Beeper and LED*.

Note:

1. The following controllers support external control of the LED and beeper: GV-AS210 / 2110 / 2120 / 410 / 4110 / 810 / 8110, and GV-AS1620.
2. The LED and beeper functions are currently unavailable for GV-RK1352 when it is accessed by the built-in keypad.

IMPORTANT: When GV-RK1352 / R1352 / DFR1352 / SR1251 is connected to a controller via an RS-485 connection, external control of the LED and beeper is not supported.

2.3 Connect the Reader to GV-AS Controller

You can connect the readers to GV-AS Controllers through Wiegand or RS-485 interface. Note that the connection between the reader and GV-AS Controller varies among controller models. For the number of readers supported by a variety of GeoVision controllers, see the [compatibility table](#).

Note:

1. GV-RK1352 / R1352 / DFR1352 is compatible with GV-AS100 / 1010 / 110 / 120 / 210 / 2110 / 2120 / 410 / 4110 / 810 / 8110, GV-AS1620, GV-CS1320. However, to enable the **keypad** function on GV-RK1352, you can only connect GV-RK1352 to the controllers through the following interfaces.
 - GV-AS100 / 110 / 120: Wiegand
 - GV-AS1010: RS-485
 - GV-AS210 / 2110 / 2120 / 410 / 4110 / 810 / 8110: Wiegand and RS-485
 - GV-AS1620: Wiegand and RS-485
 - GV-CS1320: RS-485

2. Each GV-RK1352 / R1352 / DFR1352 consumes 60 mA of power. The total power consumption of the output devices and readers connected to GV-AS Controller must be under **2.5A** (for GV-CS1320), **3A** (for GV-AS1620, GV-AS210 / 2110 / 2120), **3.5A** (for GV-AS410 / 4110) or **5A** (for GV-AS810 / 8110). Connect an external power supply if the power supplied from GV-AS Controller is insufficient.

2.3.1 Connect through Wiegand Interface

The following diagrams use **GV-RK1352** and **GV-AS810 Controller** as an example. Up to eight readers can be connected to GV-AS810 Controller through the controller’s Wiegand interface.



Note: Connection through Wiegand interface is not supported for GV-AS1010.

2.3.2 Connect through RS-485 Interface

The following diagrams use **GV-RK1352** and **GV-AS810 Controller** as an example. Up to eight readers can be connected together to the RS-485 interface on GV-AS810 Controller.

- Connecting four or less readers to GV-AS810 Controller:



- Connecting five or more readers to GV-AS810 Controller:

For readers five to eight, connect the RS-485 cable to the RS-485 interface on GV-AS810 Controller and then connect the 12V power output and GND of the reader to a 12V DC power output on the controller.

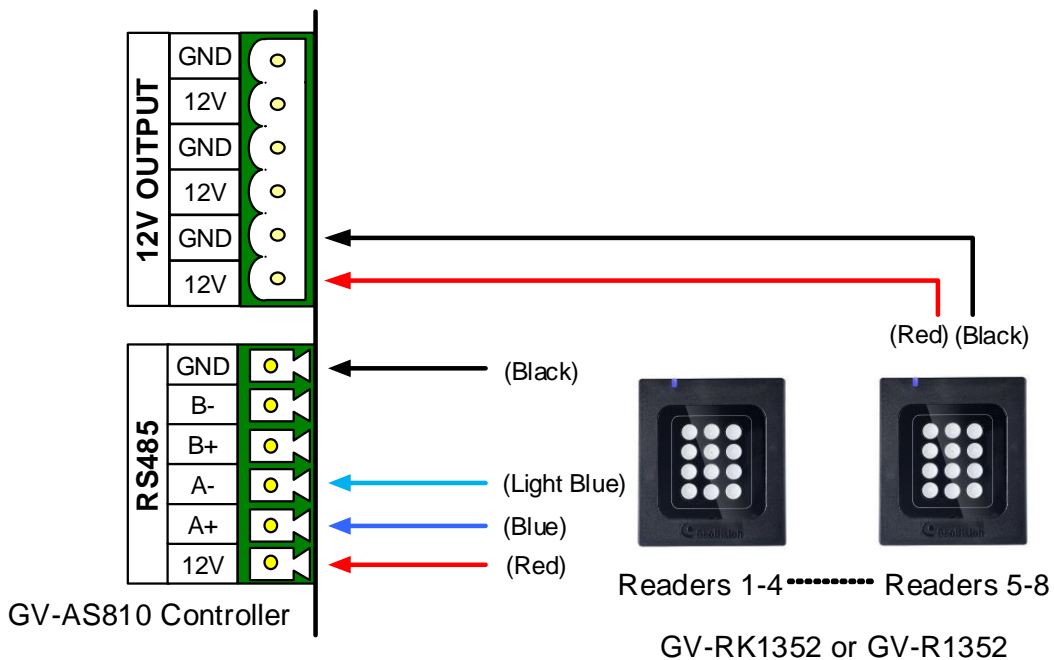

2.3.3 Define Readers on GV-AS Controller Web Interface

Since multiple readers can connect to GV-AS Controller using one RS-485 interface, you need to specify which door each reader controls. This section explains how to define readers on the Web interface of GV-AS Controller. On the Web interface, you can also set the reader to read the GID or UID on your card / key fob. Note that the Web interface of different GV-AS Controller models varies.

1. On the controller’s Web interface, click **Extended Reader**. This dialog box appears.

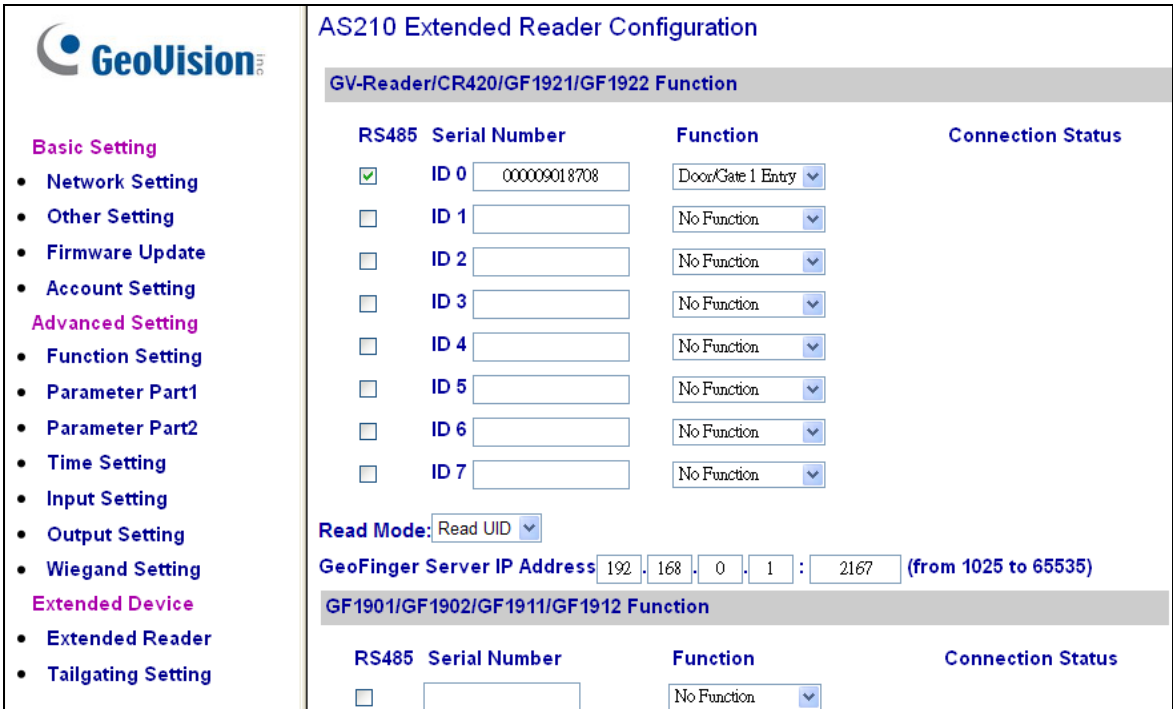

2. In the GV-Reader/CR420/GF1921/GF1922 section, select the **RS485** checkbox next to the ID number, and type the **Serial Number** which can be found on the rear panel of the reader. The ID number is assigned to the reader.

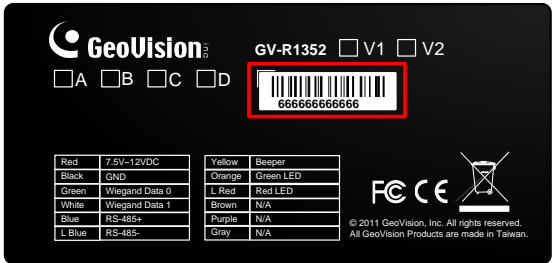

3. Select a door/gate for the reader from the **Function** drop-down list.

- Next to **Read Mode**, select **Read UID** or **Read GID** to set the connected reader to read UID (Unique Identifier) or GID (GeoVision Identifier) formatted cards / key fobs.

If you select **Read GID**, ensure there are two sets of digits on your card / key fob as shown below. If your card / key fob only has one set of digits, GID is not supported.

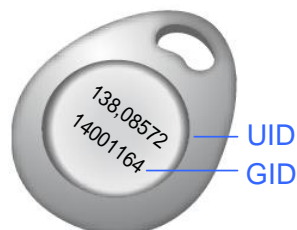
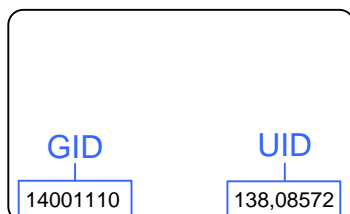

- Click **Submit**.

Note:

- When you click **Submit** on the Extended Reader page of GV-AS1010 / 210 / 2110 / 2120 / 410 / 4110 / 810 / 8110, GV-AS1620, or GV-CS1320, all readers connected through RS-485 interface will reboot.
 - GID format is only supported by GV-RK1352 / GV-R1352 / GV-DFR1352 (Rev. B) V1.2 or later.
 - If you are using third-party cards or key fobs, you must set the reader to read UID.
-

2.4 Install GV-R/RK/DFR Setup AP

GV-R/RK/DFR Setup AP allows you to set the reader's beeper, LED, ID number, master / slave status, and whether it reads UID or GID. To use the Config AP, you need to connect the reader to a PC using a RS-485 / USB converter (e.g. GV-COM, GV-Hub or GV-NET/IO Card V3.1), as illustrated below.

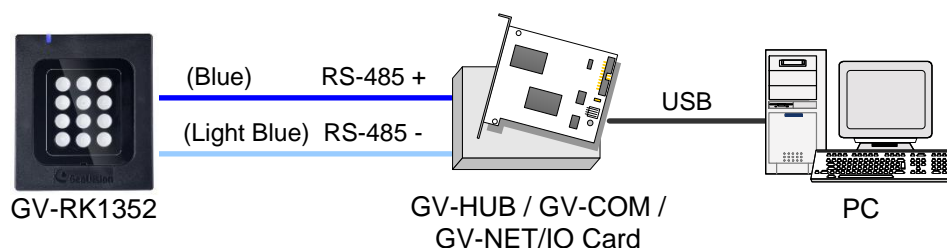

You can install the Config AP from the GeoVision website. To use a GV-COM, GV-Hub or GV-NET/IO Card V3.1, you also need to install GV-USB Device Driver to enable the device.

Downloading from GeoVision Website

1. Go to the download page of GeoVision Website:

<https://www.geovision.com.tw/download/product/GV-RK1352>

2. Download **GV-RK1352 & GV-R1352 & GV-DFR1352 Config Utility**.



3. To download GV-USB Device Driver, go to the download page:

<https://www.geovision.com.tw/download/product/GV-NET%20IO%20card%20V3.2>

2.5 Overlay Card Numbers on GV-DVR/NVR Live View

You can overlay card numbers recognized at the reader onto a camera channel on GV-DVR/NVR. To overlay card numbers on GV-DVR/NVR channels, connect the reader to GV-DVR/NVR through a RS-485 / USB converter (e.g. GV-COM, GV-Hub or GV-NET/IO Card V3.1) as illustrated below.

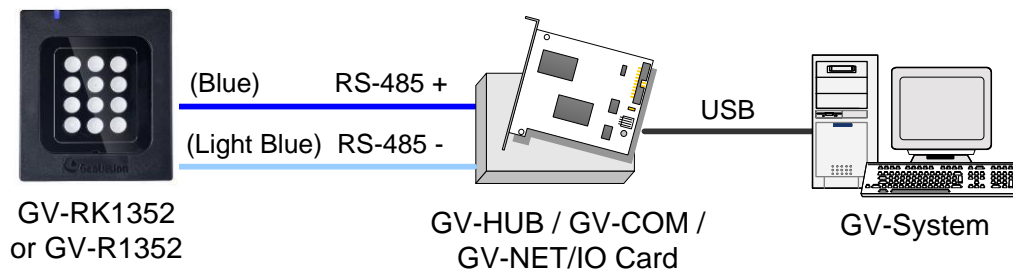

Note: GV-RK1352 / R1352 / DFR1352 is not compatible with GV-NET Card and GV-NET/IO Card of versions earlier than V3.

To overlay card numbers on GV-DVR/NVR, follow the steps in the sections below:

- **2.5.1 Define the ID and Set the Reader to Slave:** The application requires setting the reader to Slave mode. Assign a unique ID to each reader when multiple readers are connected.
- **2.5.2 Add the Reader to GV-DVR/NVR**

2.5.1 Define the ID and Set the Reader to Slave

After the reader is connected to the computer of GV-DVR/NVR, use **GV-R/RK/DFR Setup AP** to define the ID number of the reader and set the reader to Slave.

1. Run **GV-R/RK/DFR Setup AP**. See 2.4. *Install GV-R/RK/DFR Setup AP* for how to install.

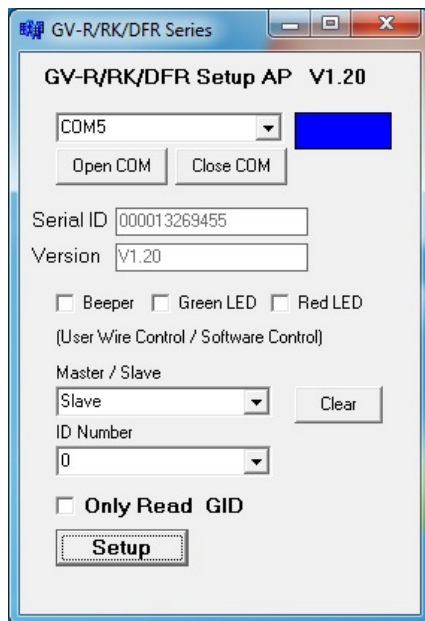

2. Select the COM port that is connected to the reader and click **Open COM**. The red square next to the COM port box should change to blue to indicate the COM port is correct.
3. Under **Master / Slave**, set the reader to **Slave**.
4. Select an **ID number** for the reader. The ID number ranges from 0 to 7.
5. Click **Setup**. The settings are sent to the reader. The serial number and firmware version of the reader will be automatically detected.

If you want to connect multiple readers to GV-DVR/NVR, you must assign each reader a unique ID number. Connect each reader to the computer one at a time, and then follow the steps above to create an ID number.

Note:

1. If the COM port is incorrect, an “***Error opening serial port***” message will appear. To verify the COM port that is connected to the reader, go to Windows Device Manager. In the Ports (COM & LPT) field, you should see the entry for **Prolific USB-to-Serial Comm Port** and the COM number currently in use.

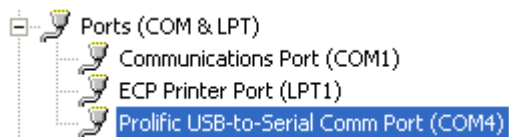

2. If you are using an older version of the Config AP, you will have to manually type the serial number of the reader. The serial number is on the rear panel of the reader.
-

2.5.2 Add the Reader to GV-DVR/NVR

1. In GV-DVR/NVR, click the **Configure** button, select **Accessories**, and select **GV Wiegand Capture Device Setting**. This dialog box appears.

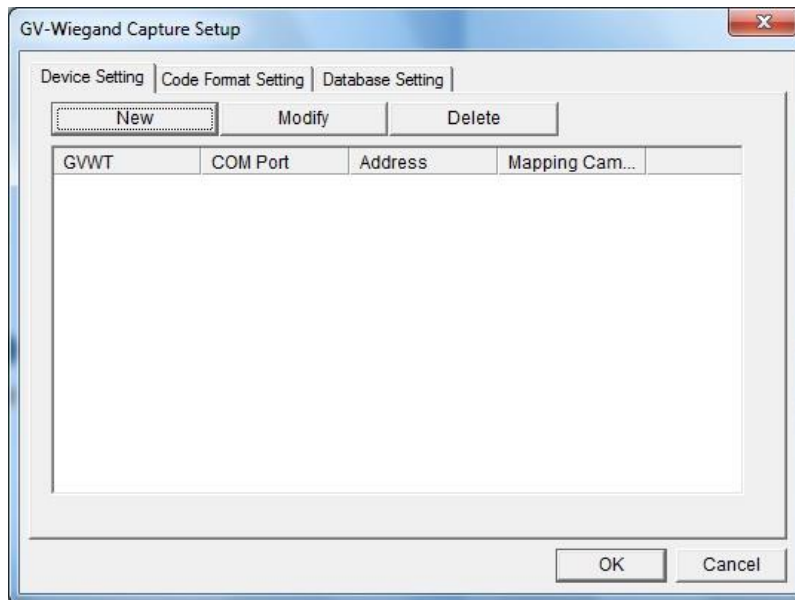

2. Click the **New** button. This dialog box appears.

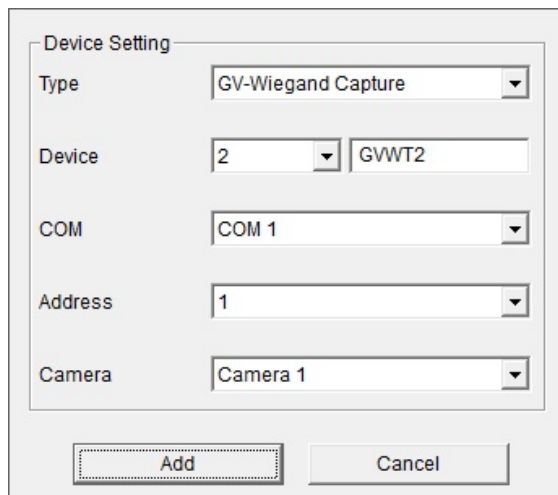

- **Type:** Select GV-Wiegand Capture.
 - **Device:** Type a number and name to help you identify the reader.
 - **COM:** Select the COM port connected to the reader.
 - **Address:** Select the ID of the connected reader you configured with GV-R/RK/DFR Config AP.
 - **Camera:** Assign the reader to a channel to overlay card numbers on live view.
3. Click the **Add** button.

2.6 Control the Beeper and LED

You can configure GV-AS Controller (AS210 / 2110 / 2120 / 410 / 4110 / 810 / 8110) to control the reader's beeper or LED externally. Through the controller's Web interface, you can configure the controller to activate the reader's red LED, green LED, or beeper in response to a specific alert event.

For this function to work, follow the steps in the three sections below:

1. Enable external control of the beeper or LED by using GV-R/RK/DFR Setup AP. See [section 2.6.1](#).
2. Connect the control wires of the beeper, Red LED or Green LED to the controller. See [section 2.6.2](#).
3. Define the beeper or LED for each door through the controller's Web interface. See [section 2.6.3](#).

Note: GV-AS1620 can also externally control the reader's LED and Beeper for access granted and denied. For details, see [GV-AS1620 User's Manual](#).

IMPORTANT: When GV-RK1352 / R1352 / DFR1352 / SR1251 is connected to a controller via an RS-485 connection, external control of the LED and beeper is not supported.

2.6.1 Enable External Control on the Reader

To enable external control of the reader's Beeper or LED, first connect the reader to a computer through a RS-485 / USB converter (e.g. GV-COM, GV-Hub or GV-NET/IO Card V3.1) as illustrated below.

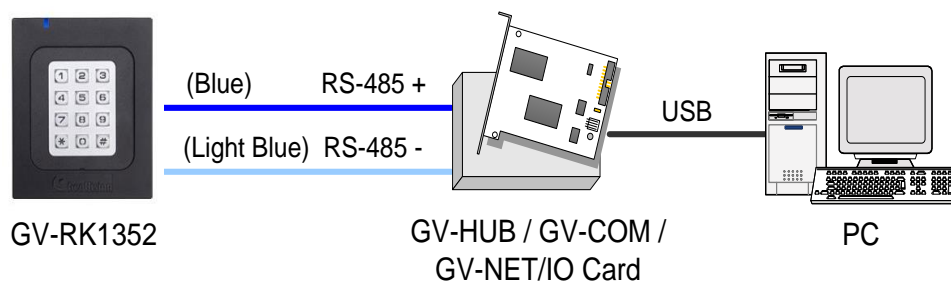

1. Start **GV-R/RK/DFR Setup AP** and select the COM port that is connected to the reader.

Note: For how to install the Config AP, see [2.4 Install GV-R/RK/DFR Setup AP](#). For how to identify the COM port of the reader, see [Note 1, 2.5.1 Define the ID and Set the Reader to Slave](#).

2. Click **Open COM**.

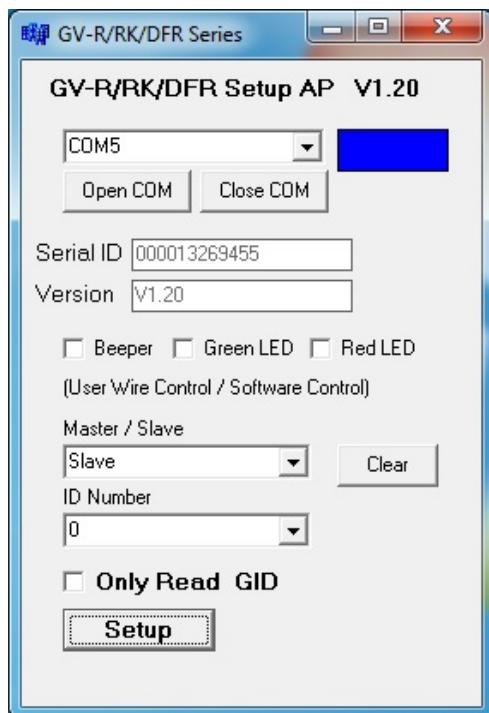

3. To enable external control of Beeper or LED, select **Beeper**, **Green LED** or **Red LED**.
4. Select **Master** from the Master / Slave drop-down list.
5. Select an ID number for the reader. Make sure the ID number on the Config AP matches that set on the Extended Reader page of the controller's Web interface.
6. Click **Setup**. The settings are sent to the reader. The serial number and the firmware version of the reader are automatically detected.

If you want to control multiple readers with a controller, connect each reader to the computer one at a time, and follow the above steps to enable its external control.

2.6.2 Connect the Beeper and LED

Connect the control wires of the beeper, Red LED, or Green LED to any of the outputs on the GV-AS Controller (GV-AS210 / 2110 / 2120 / 410 / 4110 / 810 / 8110).

Wiring LED to GV-AS Controller

The diagram below shows how to wire Green LED using GV-RK1352 and GV-AS810 as an example. Use the light red wire instead for Red LED.

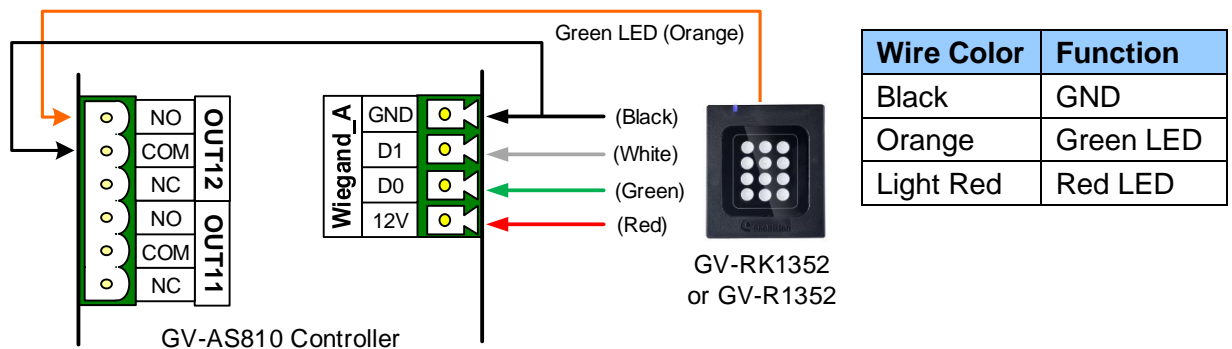

Wiring Beeper to GV-AS Controller

The diagram below shows how to wire the beeper using GV-RK1352 and GV-AS810 as an example.

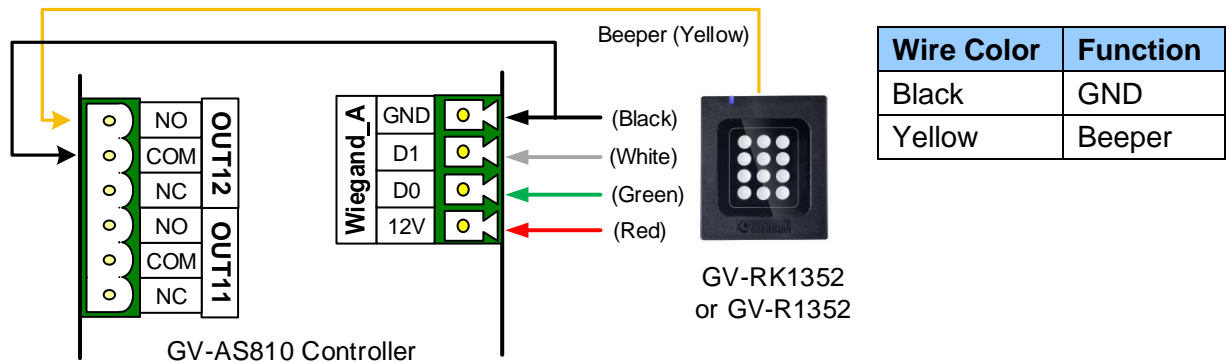

After wiring the beeper, go to GV-ASManager and select the alarm conditions that will activate it. To configure the alarm conditions in GV-ASManager, right-click the controller in the device list, select **Settings**, and then the **Door / Gate** tab.

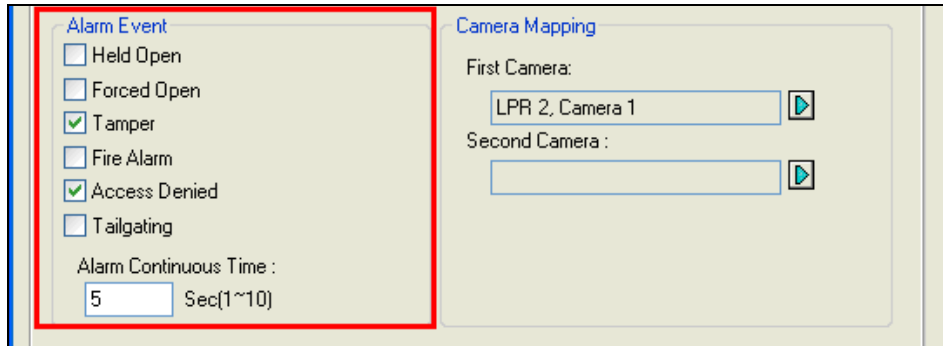

2.6.3 Set the Beeper and LED for Each Door/Gate

After connecting the wires for the beeper or LED, specify the conditions to activate the beeper or LED on the GV-AS210 / 2110 / 2120 / 410 / 4110 / 810 / 8110 Web interface.

1. On the controller's Web interface, click **Output Setting**. This page appears.

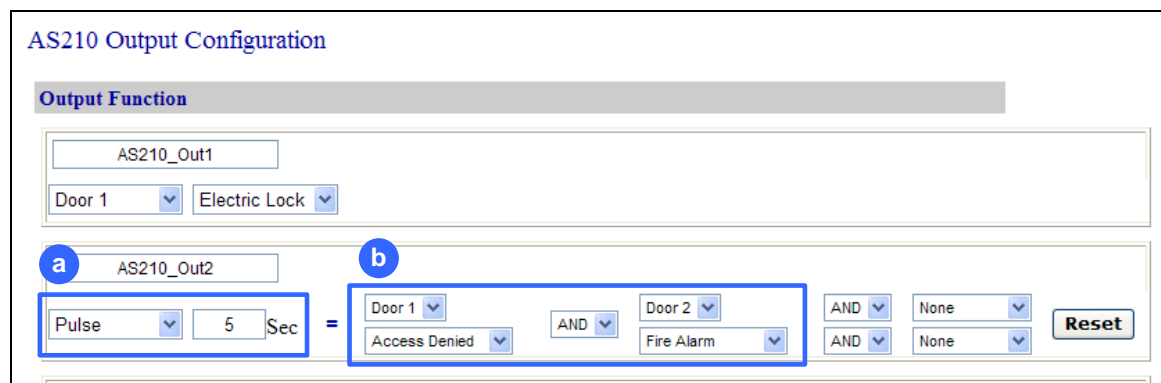

2. Find the output # wired to the beeper or LED and specify up to 2 alarm conditions to activate the beeper or LED.
 - a. **Output Type:** Select **Normal**, **Toggle** or **Pulse**. If you select Pulse, specify the duration in seconds for the beeper or LED to be activated.
 - b. **Output Conditions:** Select the door and the alarm condition to activate the beeper or LED. Up to 2 sets of output conditions can be set.
3. Click **Submit**.

2.7 Configure Card Identifier

The reader by default reads the UID (Unique Identifier) on access cards or key fobs. Using **GV-R/RK/DFR Setup AP**, you can set the reader to read GID (GeoVision Identifier) instead.

Note:

1. For how to install the Config AP, see [2.4 Install GV-R/RK/DFR Setup AP](#). For how to identify the COM port of the reader, see [Note 1](#), [2.5.1 Define the ID and Set the Reader to Slave](#).
 2. GID format is only supported by GV-RK1352 / GV-R1352 / GV-DFR1352 (Rev. B) V1.2 or later.
 3. GID is only supported by GeoVision access cards and key fobs.
-

1. Run **GV-R/RK/DFR Setup AP**.

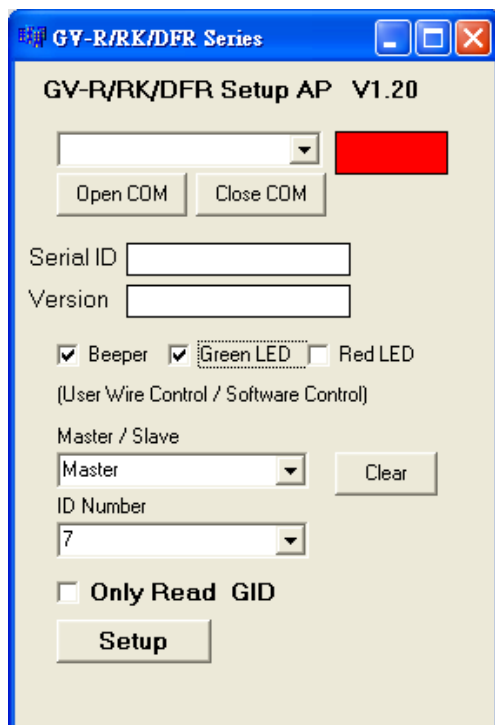

2. Select the COM port that is connected to the reader and click **Open COM**. The red square next to the COM port box should change to blue to indicate the COM port is correct.
3. To set the reader to read GID, select **Only Read GID**.

4. Click **Setup** to apply the setting. The serial number and firmware version of the reader is automatically detected.

To use GID, make sure that your card / key fob has two sets of digits as shown below. If your card / key fob has only one set of digits, GID is not supported.

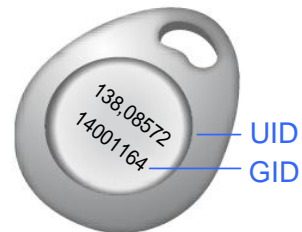
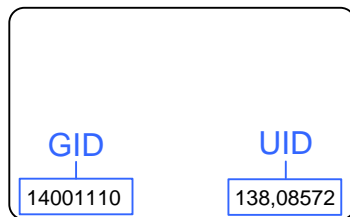

2.8 Firmware Upgrade

GeoVision periodically releases updated firmware on its website. The new firmware can be simply loaded into the reader by using **Update Utility** included in the Software CD.

Important Notes before You Start

Before you start updating the firmware, please read these important notes:

1. While the firmware is being updated, the power supply must not be interrupted.
2. Do not turn the power off within 10 minutes after the firmware is updated.

WARNING: The interruption of power supply during updating causes not only update failures but also damages to the device. In this case, please contact your sales representative and send your device back to GeoVision for repair.

To upgrade firmware:

1. Insert the Software CD and select **Run Firmware Update Utility**. This dialog box appears.

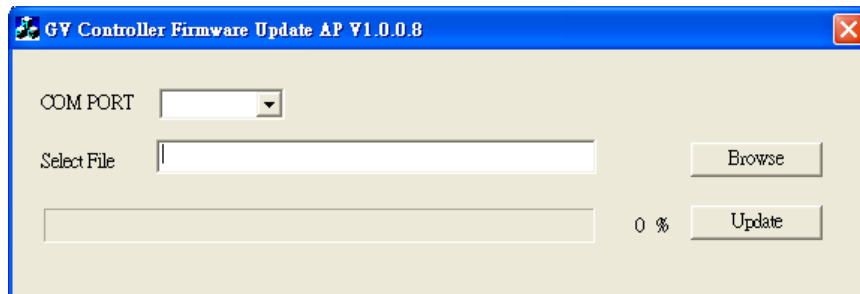

2. Select the COM port of the reader.
3. Click the **Browse** button to locate the firmware file (.bin) saved at your local computer.
4. Click **Update**.
5. The LED indicator should flash purple during the process of firmware upgrading. When the process is complete, the reader will be sounded twice and the LED indicator will change to green.

Note: You can also download the firmware upgrade utility from the [link](#).

2.9 Specifications

	GV-RK1352	GV-R1352	GV-DFR1352 (Rev. B)
CPU	8-bit microprocessor		
Frequency	13.56 MHz ISO 14443A		
Wiegand Interface	Wiegand 26- / 34 bits, distance 100 m (328.1ft), 24 AWG, 13V DC min., 85 °C min		
RS-485	9,600 bps, distance 600 m (1968.50 ft), 24 AWG, 13V DC min., 85 °C min		
Input Rating	7.5V DC~12V DC, 200mA		
LED	Red, Green and Blue LED		
Audio	Buzzer		
Reader Color	Black		
Supported ID Formats	UID and GID		
Operating Temperature	-35 °C ~ 66°C / -31 °F ~ 150.8 °F		
Operating Humidity	10% ~ 90% (no condensation)		
Dimensions (W x H x D)	95 x 108 x 23 mm / 3.74 x 4.25 x 0.91 in	65.8 x 115.6 x 20.5 mm / 4.6 x 2.6 x 0.8 in	20.9 x 105.6 x 20.5 mm / 0.8 x 4.2 x 0.8 in
Weight	260 g / 0.57 lb	120 g / 0.26 lb	80 g / 0.17 lb
Ingress Protection	IP66		
Certification	CE, FCC, RoHS, UL 294, CUL		

For the number of readers supported by a variety of GeoVision controllers, see the [compatibility table](#).

Note: The GID format is only supported by GV-RK1352 / GV-R1352 / GV-DFR1352 (Rev. B) V1.2 or later.

2.10 Accessory (GV-RK1352 and GV-R1352 Only)

Optional accessories can expand the capabilities and versatilities of your GV-RK1352 and GV-R1352. Consult our sales representative for more information.

GV-MountA900	GV-MountA900 is a mounting plate that allows you to attach GV-RK1352 and GV-R1352 to a US single gang power box. <ul style="list-style-type: none">• Dimensions: 100 x 68 mm / 3.9 x 2.7 in• Weight: 55 g / 0.12 lb
---------------------	--

Connecting GV-MountA900

1. Screw GV-MountA900 to the US single gang power box through holes C.
2. Thread the cable through GV-MountA900 and then attach the reader.
 - GV-R1352: Secure through holes A
 - GV-RK1352: Secure through holes B



Chapter 3 GV-RKD1352

GV-RKD1352 is a card reader with keypad, designed to read PIN codes and access cards. Featured with Wiegand and RS-485 interfaces, GV-RKD1352 can be connected to any standard access control systems. GV-RKD1352 comes with IP65 rated ingress protection suitable for indoor and outdoor applications.

3.1 Packing List



Reader x 1



Quick Start Guide x 1

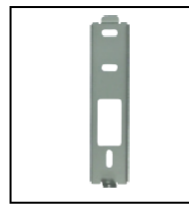

Plate x 1



Hex Key wrench x 1
Screw x 3 Cable x 1

3.2 Compatible Products

- **GV-ASManager:** V5.3.3 or later
- **GV-AS210 / 2110 / 2120, GV-AS810 / 8110 / 8111, GV-AS410 / 4110 / 4111:** V2.41 or later (only Weigand interface supported)
- **GV-AS1620:** V1.05 or later
- **GV-CS1320:** V3.10 or later

3.3 Physical Descriptions

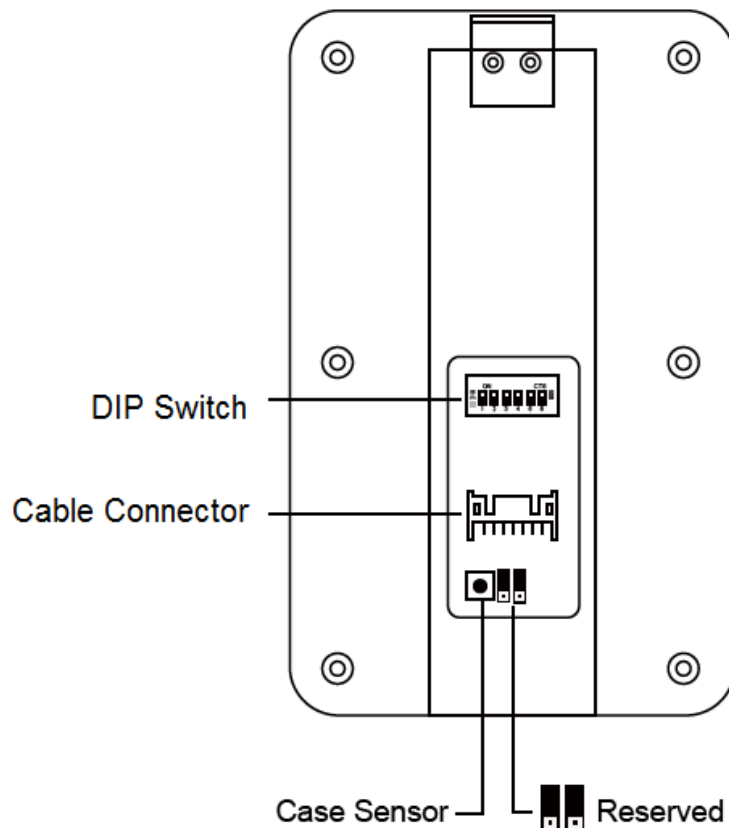

- **DIP Switch:** To define the reader's ID for a daisy chain connection, set up the first 5 DIP switches as listed below. DIP (6) is for card format settings.

Node ID	Configuration
0	00000
1	10000
2	01000
3	11000
4	00100
5	10100
6	01100
7	11100
8	00010
9	10010
10	01010
11	11010
12	00110
13	10110
14	01110
15	11110

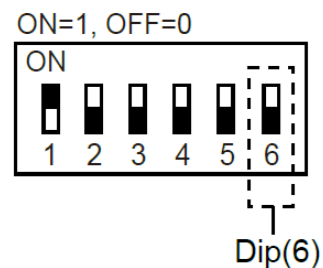

Card Identifier Setting

To only support DES-ID (for MIFARE DESFire cards) or GID (GeoVision Identifier) formatted cards, turn **ON** for the DIP (6).

Note:

1. GV-AS DES cards contain two types of ID: UID (Unique Identifier) and DES ID. When only DES ID is required, turn on the DIP (6).
 2. Every time when the DIP settings are changed, the reader needs to be restarted to apply them.
-

- **Cable Connector:** Connect the reader to the controller based on the following pin definitions:

Pin	Wire Color	Wiegand	RS-485
1	Red	DC 12V	DC 12V
2	Black	Ground	Ground
3	Yellow	-	RS-485+
4	Blue	-	RS-485-
5	Gray	(Reserved)	-
6	Pink	-	-
7	Orange & White	Ground	-
8	Orange	-	-
9	Brown	Green LED Control	-
10	Purple	Beep Control	-
11	White	Case Sensor (To Controller GND)	-
12	Green	Case Sensor (To Controller Temper Sensor)	-
13	Red & White	Wiegand Data 0	-
14	Gray & White	Wiegand Data 1	-

Note: The RS-485 interface supports either RS-485 or OSDP communication but not both at the same time.

3.4 Installation

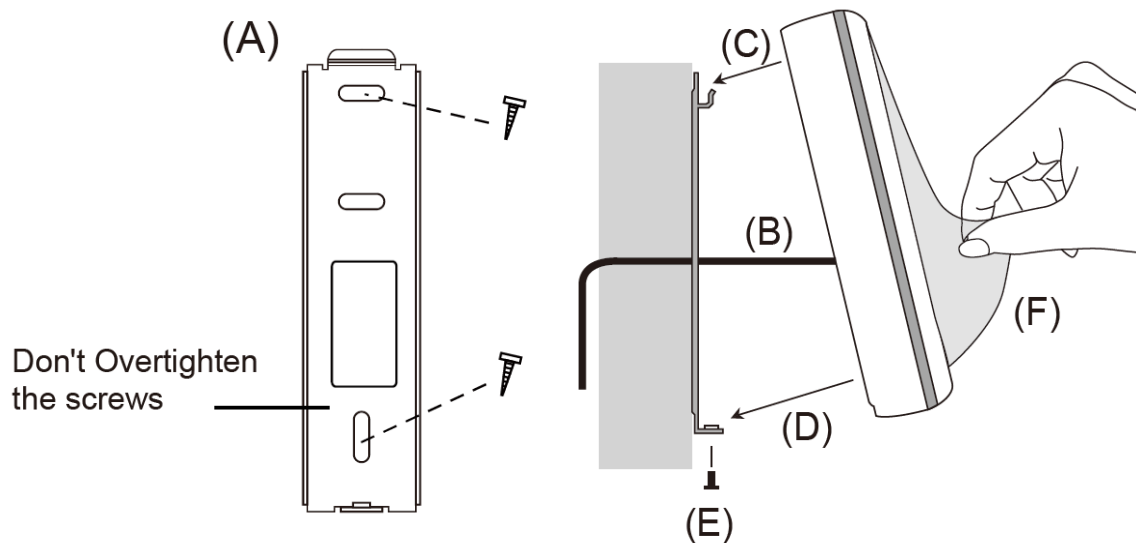

Before the hardware installation, refer to *Physical Descriptions* for the Node ID settings.

- A. Mount the backplate onto the wall or back box (US standard 120 type). Note DO NOT overtighten the backplate screws during installation to prevent distortion.
- B. Connect the wires in accordance with the **Wiring Note** below.
- C. Make sure the backplate and the upper cover guide of the reader are aligned.
- D. Install the upper cover of the reader to the backplate.
- E. Fasten the screw onto the bottom of the reader.
- F. Tear off the protective film.

Wiring Note:

1. Use minimum 22 AWG double-shielded aluminum mylar foil twisted pair cable for the connection between the reader and the controller.
2. In order to reduce long distance noise, the isolated net of transmission cable should connect to both ends of device ground.
3. The distance between two readers should be over 30 cm to prevent radio frequency interference from each other.
4. Mounting the reader around metal could affect read range. Metal of any type around the reader should be avoided while mounting.
5. The distance between the reader and the controller should not exceed 30 meters (98 ft) (for Wiegand model only).
6. For optimum read range, use DC Linear power adaptor for the reader's power supply.
7. In order to ensure the reader's normal operation, input voltage should be $12V \pm 10\%$.

8. If the reader is installed in an open area or highly humid environment, it is recommended to protect the reader with an external shielding cover.
9. RS-485 communication baud rate is 9600.

3.5 Keypad

When using the reader, you can enter the door's Common Password or the card's PIN code on the keypad to gain access. The access mode is set in GV-ASManager (software).

- **0~9 Number Keys:** Press the number keys to enter a PIN code or password.
- **E Key:** Press the E key to confirm an entry.
- **C Key:** Press the C key to cancel an entry.

IMPORTANT: The Card and PIN Code mode requires users to enter the card's PIN code, press the E key to confirm the code, and then present the card to gain access.

3.6 LED Status and Beeper

The reader has the following LED status and beeper actions by default:

Condition	Wiegand	RS-485
Standby	Constant Red	No light
Access Denied	Beep once (No LED)	Flash Red momentarily + Beep three times
Access Granted	Beep once (No LED)	Flash Green momentarily + Beep twice

The reader includes external control wires for the Green LED and Beeper for Wiegand connection. You can change the default settings of the LED and Beeper by connecting these control wires to the GV-AS Controller.

3.7 Firmware Upgrade

GeoVision periodically updates its website with the latest firmware. Using the provided tool, the new firmware can be easily installed on the reader.

First, prepare a RS-485 / USB converter, and connect the reader to a PC as illustrated below.

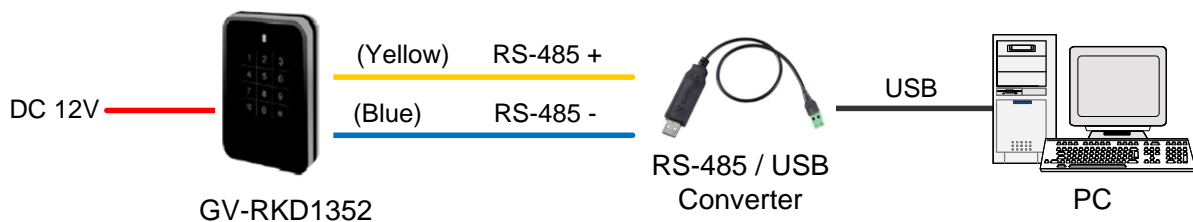

To upgrade firmware:

1. Download the **Firmware Upgrade Tool** from our [website](#) to the PC.
2. Run the Tool. This dialog box appears.

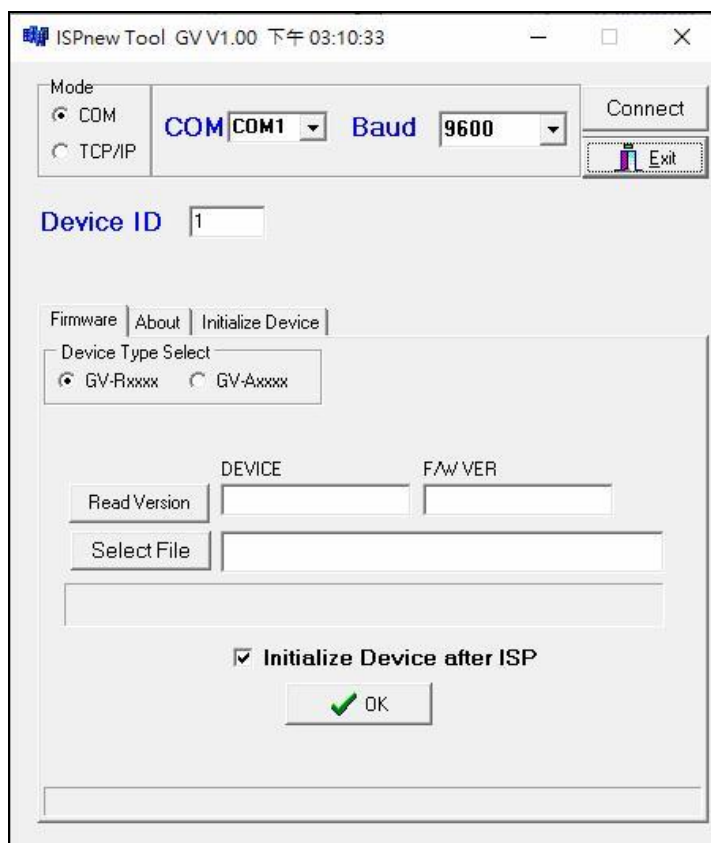

3. Select the **COM** port used by the reader in the PC, set the **Baud** rate to **9600**, and click **Connect**.
4. Make sure the **Device ID** is the same as the reader's current ID. If not, revise the ID.

5. Click **Read Version**. The reader's name and firmware version should be displayed.
6. Click **Select File** to locate the firmware file.
7. Click **Initialize Device after ISP**, and then **OK** to start firmware upgrade.
8. After firmware upgrade, the message "Are you sure you want to the device to initialize?" appears. Click **Yes**.
9. After initialized, the reader flashes green once with beeping five times, and then LED turns to red. Click **Exit** to close the tool.

Note:

1. For the **Device ID**, check switch settings at the rear panel of the reader. See 3.3 *Physical Descriptions*.
2. If firmware upgrade fails due to a loose wire connection and the reader flashes green constantly after reconnecting to power, do the following:
 - A. Rewire the reader properly.
 - B. Set the **Baud** rate to **19200** in the ISP New Tool.
 - C. Click **Read Version**. The FW version should display **V0.00**.
 - D. Select the firmware file.
 - E. Click **Initialize Device after ISP**, and then **OK** to start firmware upgrade.

After Step E, GV-RKD1352 has been updated but not initialized yet. To initialize the reader, follow the steps below:

- F. Set the **Baud** rate to **9600** in the ISP New Tool.
 - G. Click **Initialize Device after ISP**, and then **OK** to start initialization.
-

3.8 Specifications

For details, please see the [datasheet](#).

For the number of readers supported by a variety of GeoVision controllers, see the [compatibility table](#).

Chapter 4 GV-R1355

The card reader GV-R1355, which has Wiegand and RS-485 interfaces, can be integrated into any standard access control system. GV-R1355 has IP66 ingress protection, making it suitable for both indoor and outdoor applications.

4.1 Packing List

1. Reader
2. Screw x 3
3. Quick Start Guide

4.2 Compatible Products

- **GV-ASManager:** V5.3.3 or later
- **GV-AS210 / 2110 / 2120, GV-AS810 / 8110 / 8111, GV-AS410 / 4110 / 4111:** V2.41 or later (only Weigand interface supported)
- **GV-AS1620:** V1.05 or later
- **GV-CS1320:** V3.10 or later

4.3 Physical Descriptions

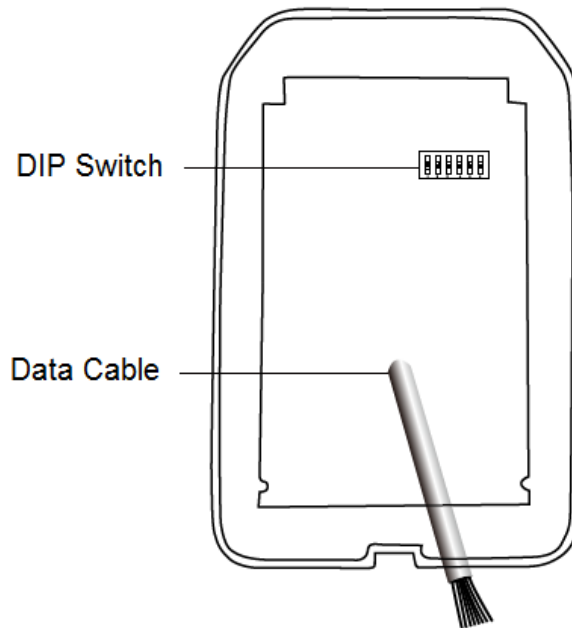

- **DIP Switch:** To define the reader's ID for a daisy chain connection, set up the first 5 DIP switches as listed below. DIP (6) is for card format settings.

Node ID	Configuration
0	00000
1	10000
2	01000
3	11000
4	00100
5	10100
6	01100
7	11100
8	00010
9	10010
10	01010
11	11010
12	00110
13	10110
14	01110
15	11110

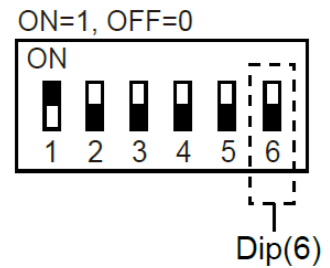

Card Identifier Setting

To set the reader to only read DES-ID (for MIFARE DESFire cards) or GID (GeoVision Identifier) formatted cards, turn **ON** for the DIP (6).

Note:

1. GV-AS DES cards contain two types of ID: UID (Unique Identifier) and DES-ID. When only DES-ID is required, turn on the DIP (6).
 2. Every time when the DIP settings are changed, the reader needs to be restarted to apply them.
-

- **Cable Connector:** Connect the reader to the controller based on the following pin definitions:

Pin	Wire Color	Wiegand	RS-485
1	Red	DC 12V	DC 12V
2	Black	Ground	Ground
3	Yellow	-	RS-485+
4	Blue	-	RS-485-
5	Purple	Beep Control	
6	Brown	Green LED Control	
7	Green	-	
8	White	-	
9	Light Blue	Wiegand Data 0	
10	Gray	Wiegand Data 1	

Note: The RS-485 interface supports either RS-485 or OSDP communication but not both at the same time.

4.4 Installation

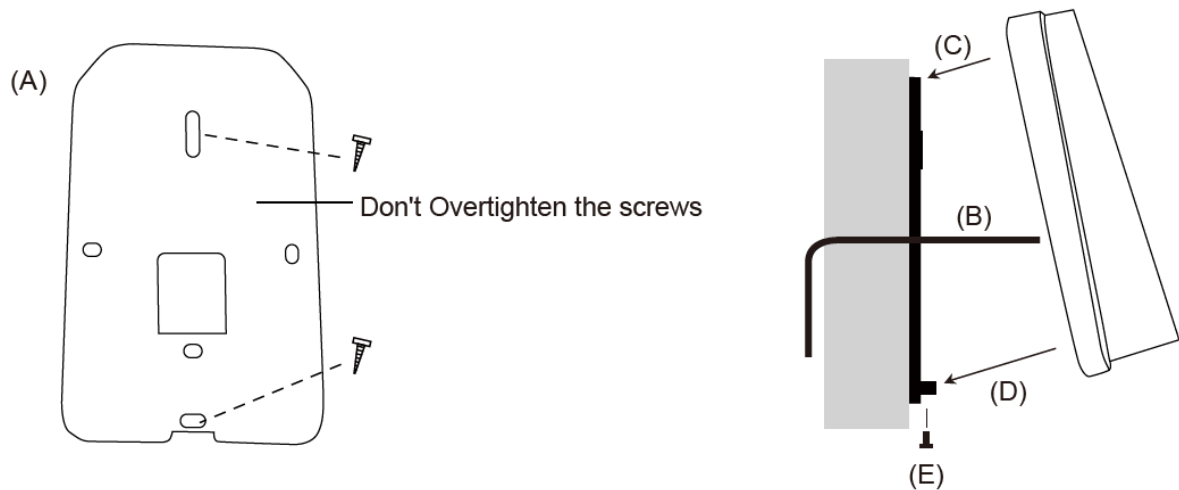

Before the hardware installation, refer to *Physical Descriptions* for the Node ID settings.

- A. Mount the backplate onto the wall or back box (US standard 120 type). Note DO NOT overtighten the backplate screws during installation to prevent distortion.
- B. Connect the wires in accordance with the wiring notes below.
- C. Make sure the backplate and the upper cover guide of the reader are aligned.
- D. Install the upper cover of the reader to the backplate.
- E. Fasten the screw onto the bottom of the reader.

Wiring Note:

1. Use minimum 22 AWG double-shielded aluminum mylar foil twisted pair cable for the connection between the reader and the controller.
2. In order to reduce long distance noise, the isolated net of transmission cable should connect to both ends of device ground.
3. The distance between two readers should be over 30 cm to prevent radio frequency interference from each other.
4. Mounting the reader around metal could affect read range. Metal of any type around the reader should be avoided while mounting.
5. The distance between the reader and the controller should not exceed 30 meters (98 ft) (for Wiegand model only).
6. For optimum read range, use DC Linear power adaptor for the reader's power supply.
7. In order to ensure the reader's normal operation, input voltage should be $12V \pm 10\%$.
8. If the reader is installed in an open area or highly humid environment, it is recommended to protect the reader with an external shielding cover.
9. RS-485 communication baud rate is 9600.

4.5 LED Status and Beeper

The reader has the following LED status and beeper actions by default:

Condition	Wiegand	RS-485
Standby	Constant Red	No light
Access Denied	Beep once (No LED)	Flash Red momentarily + Beep three times
Access Granted	Beep once (No LED)	Flash Green momentarily + Beep twice

The reader includes external control wires for the Green LED and Beeper for Wiegand connection. You can change the default settings of the LED and Beeper by connecting these control wires to the GV-AS Controller.

4.6 Firmware Upgrade

GeoVision will periodically release the updated firmware on the website. The new firmware can be simply loaded into the reader by using the tool provided. For how to upgrade the firmware, see *3.7 Firmware Upgrade*.

4.7 Specifications

For details, please see the [datasheet](#).

For the number of readers supported by a variety of GeoVision controllers, see the [compatibility table](#).

Chapter 5 GV-RKR1355

GV-RKR1355 is a scramble keypad reader with numeric keys displayed in random order after cards are swiped or PINs are entered. Featured with Wiegand and RS-485 interfaces, GV-RKR1355 can be integrated to any standard access control systems.

5.1 Packing List

1. GV-RKR1355
2. Screw x 4
3. Cable
4. Quick Start Guide

5.2 Compatible Products

- **GV-ASManager:** V5.3.3 or later
- **GV-AS210 / 2110 / 2120, GV-AS810 / 8110 / 8111, GV-AS410 / 4110 / 4111:** V2.41 or later (only Weigand interface supported)
- **GV-AS1620:** V1.05 or later
- **GV-CS1320:** V3.10 or later

5.3 Physical Descriptions

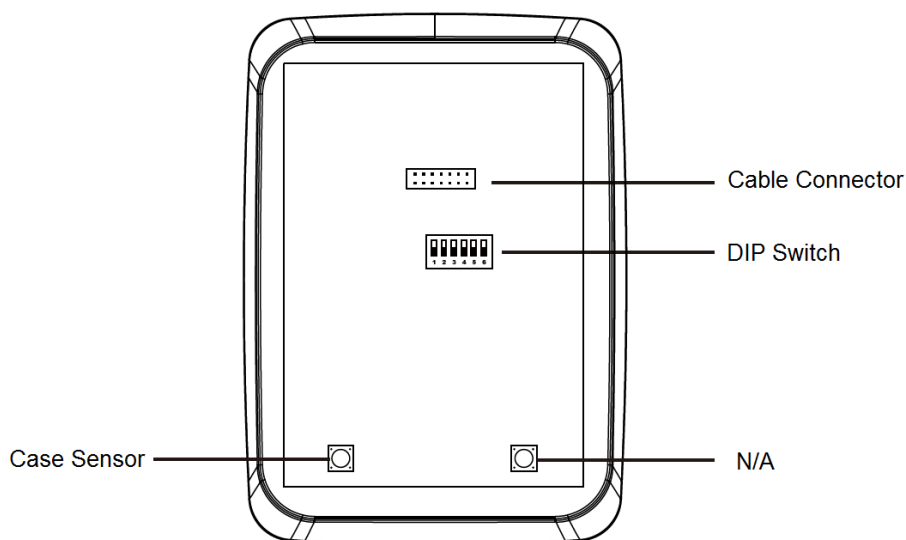

- **DIP Switch:** To define the reader's ID for a daisy chain connection, set up the first 5 DIP switches as listed below. DIP (6) is for card format settings.

Node ID	Configuration
0	00000
1	10000
2	01000
3	11000
4	00100
5	10100
6	01100
7	11100
8	00010
9	10010
10	01010
11	11010
12	00110
13	10110
14	01110
15	11110

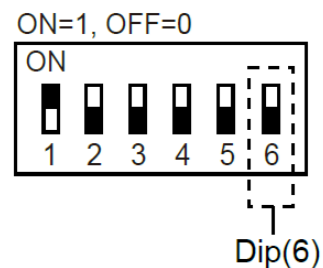

Card Identifier Setting

To set the reader to only read DES-ID (for MIFARE DESFire cards) or GID (GeoVision Identifier) formatted cards, turn **ON** for the DIP (6).

Note:

1. GV-AS DES cards contain two types of ID: UID (Unique Identifier) and DES-ID. When only DES-ID is required, turn on the DIP (6).
 2. Every time when the DIP settings are changed, the reader needs to be restarted to apply them.
-

- **Cable Connector:** Connect the reader to the controller based on the following pin definitions:

Pin	Wire Color	Wiegand	RS-485
1	Red	DC 12V	DC 12V
2	Black	Ground	Ground
3	Yellow	-	RS-485+
4	Blue	-	RS-485-
5	Gray	-	-
6	Pink	-	-
7	Orange & White	Ground	-
8	Orange	-	-
9	Brown	Green LED Control	-
10	Purple	Beep Control	-
11	White	Case Sensor (To Controller GND)	-
12	Green	Case Sensor (To Controller Temper Sensor)	-
13	Red & White	Wiegand Data 0	-
14	Gray & White	Wiegand Data 1	-

Note: The RS-485 interface supports either RS-485 or OSDP communication but not both at the same time.

5.4 Installation

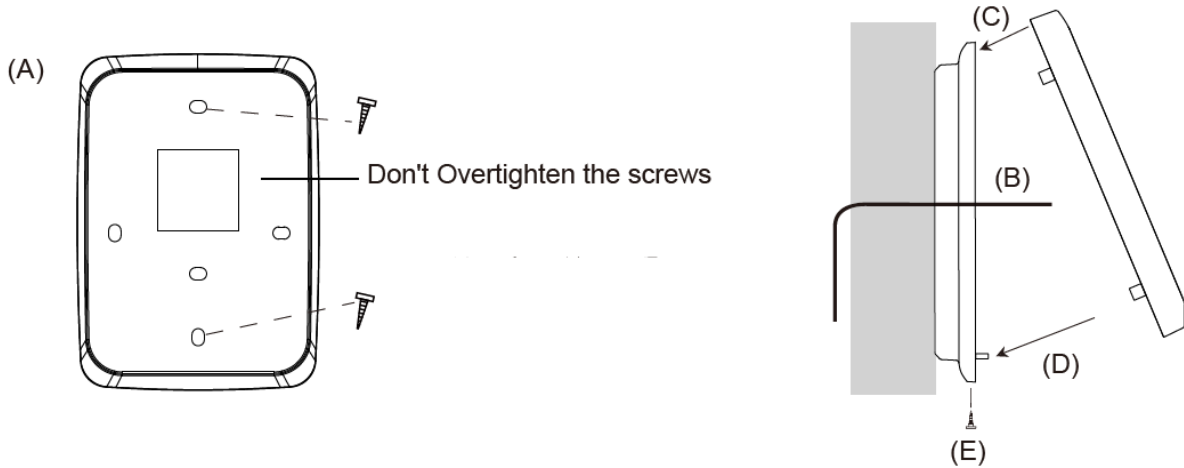

Before the hardware installation, refer to *Physical Descriptions* for the Node ID settings.

- A. Mount the backplate onto the wall or back box (US standard 120 type). Note DO NOT overtighten the backplate screws during installation to prevent distortion.
- B. Connect the wires in accordance with the **Wiring Note** below.
- C. Make sure the backplate and the upper cover guide of the reader are aligned.
- D. Install the upper cover of the reader to the backplate.
- E. Fasten the screw onto the bottom of the reader.

Wiring Note:

1. Use minimum 22 AWG double-shielded aluminum mylar foil twisted pair cable for the connection between the reader and the controller.
2. In order to reduce long distance noise, the isolated net of transmission cable should connect to both ends of device ground.
3. The distance between two readers should be over 30 cm to prevent radio frequency interference from each other.
4. Mounting the reader around metal could affect read range. Metal of any type around the reader should be avoided while mounting.
5. The distance between the reader and the controller should not exceed 30 meters (98 ft) (for Wiegand model only).
6. For optimum read range, use DC Linear power adaptor for the reader's power supply.
7. In order to ensure the reader's normal operation, input voltage should be $12V \pm 10\%$.
8. If the reader is installed in an open area or highly humid environment, it is recommended to protect the reader with an external shielding cover.
9. RS-485 communication baud rate is 9600.

5.5 Keypad

When using the reader, you can enter the door's Common Password or the card's PIN code on the keypad to gain access. The access mode is set in GV-ASManager (software).

- **0~9 Number Keys:** Press the number keys to enter a PIN code or password.
- **E Key:** Press the E key to confirm an entry.
- **C Key:** Press the C key to cancel an entry.

IMPORTANT: The Card and PIN Code mode requires users to enter the card's PIN code, press the E key to confirm the code, and then present a card to gain access.

5.6 LED Status and Beeper

The reader has the following LED status and beeper actions by default:

Condition	Wiegand	RS-485
Standby	Constant Red	No light
Access Denied	Beep once (No LED)	Flash Red momentarily + Beep three times
Access Granted	Beep once (No LED)	Flash Green momentarily + Beep twice

The reader includes external control wires for the Green LED and Beeper for Wiegand connection. You can change the default settings of the LED and Beeper by connecting these control wires to the GV-AS Controller.

5.7 Firmware Upgrade

GeoVision periodically updates its website with the latest firmware. Using the provided tool, the new firmware can be easily installed on the reader. For how to upgrade the firmware, see *3.7 Firmware Upgrade*.

5.8 Specifications

For details, please see the [datasheet](#).

For the number of readers supported by a variety of GeoVision controllers, see the [compatibility table](#).

Chapter 6 GV-RKV1355

GV-RKV1355 is a vandal-resistant keypad reader capable of reading PIN codes and access cards. To successfully resist vandalism, the reader's case is made of zina alloy, making it suited for high-security locations such as banks and prisons. Featured with Wiegand and RS-485 interfaces, GV-RKV1355 can be integrated to any standard access control systems. Furthermore, the reader complies with IP66 ingress protection, making it perfect for both indoor and outdoor applications.

6.1 Packing List

1. GV-RKV1355
2. Plate
3. Hex Key Wrench
4. Screw x 3
5. Quick Start Guide

6.2 Compatible Products

- **GV-ASManager:** V5.3.3 or later
- **GV-AS210 / 2110 / 2120, GV-AS810 / 8110 / 8111, GV-AS410 / 4110 / 4111:** V2.41 or later (only Weigand interface supported)
- **GV-AS1620:** V1.05 or later
- **GV-CS1320:** V3.10 or later

6.3 Physical Descriptions

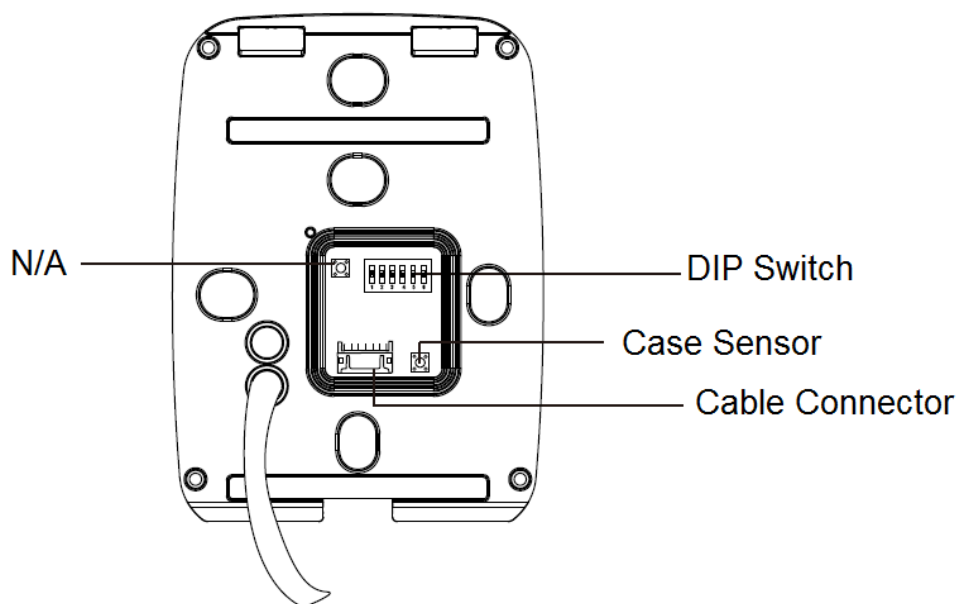

- **DIP Switch:** To define the reader's ID for a daisy chain connection, set up the first 5 DIP switches as listed below. DIP (6) is for card format settings.

Node ID	Configuration
0	00000
1	10000
2	01000
3	11000
4	00100
5	10100
6	01100
7	11100
8	00010
9	10010
10	01010
11	11010
12	00110
13	10110
14	01110
15	11110

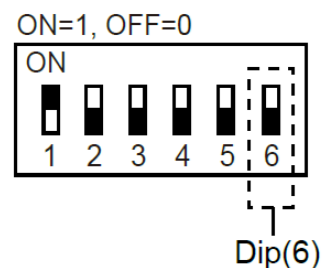

Card Identifier Setting

To set the reader to only read DES-ID (for MIFARE DESFire cards) or GID (GeoVision Identifier) formatted cards, turn **ON** for the DIP (6).

Note:

1. GV-AS DES cards contain two types of ID: UID (Unique Identifier) and DES-ID . When only DES-ID is required, turn on the DIP (6).
 2. Every time when the DIP settings are changed, the reader needs to be restarted to apply them.
-

- **Cable Connector:** Connect the reader to the controller based on the following pin definitions:

Pin	Wire Color	Wiegand	RS-485
1	Red	DC 12V	DC 12V
2	Black	Ground	Ground
3	Yellow	-	RS-485+
4	Deep Blue	-	RS-485-
5	Gray	-	-
6	Pink	-	-
7	White & Black	Ground	-
8	Orange	-	-
9	Brown	Green LED Control	-
10	Purple	Beep Control	-
11	White	Case Sensor (To Controller GND)	-
12	Green	Case Sensor (To Controller Temper Sensor)	-
13	Red & Black	Wiegand Data 0	-
14	Light Blue	Wiegand Data 1	-

Note: The RS-485 interface supports either RS-485 or OSDP communication but not both at the same time.

6.4 Installation

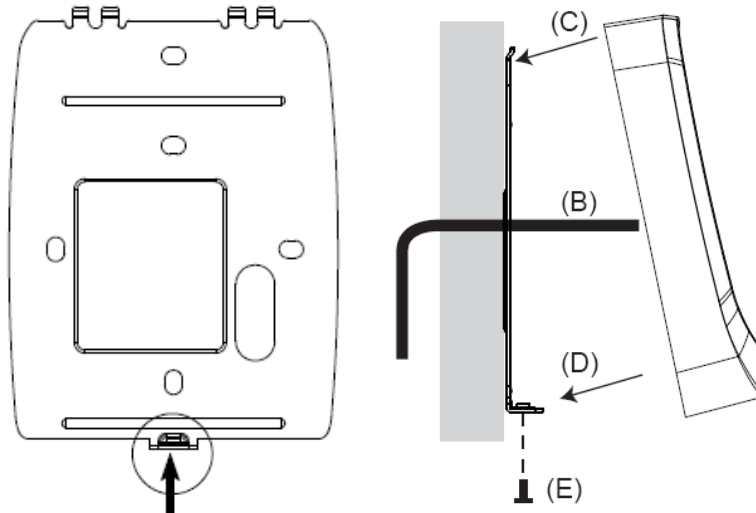

Before the hardware installation, refer to *Physical Descriptions* for the Node ID settings.

- A. Mount the backplate onto the wall or back box (US standard 120 type). Note DO NOT overtighten the backplate screws during installation to prevent distortion.
- B. Connect the wires in accordance with the **Wiring Note** below.
- C. Make sure the backplate and the upper cover guide of the reader are aligned.
- D. Install the upper cover of the reader to the backplate.
- E. Fasten the screw onto the bottom of the reader.

Wiring Note:

1. Use minimum 22 AWG double-shielded aluminum mylar foil twisted pair cable for the connection between the reader and the controller.
2. In order to reduce long distance noise, the isolated net of transmission cable should connect to both ends of device ground.
3. The distance between two readers should be over 30 cm to prevent radio frequency interference from each other.
4. Mounting the reader around metal could affect read range. Metal of any type around the reader should be avoided while mounting.
5. The distance between the reader and the controller should not exceed 30 meters (98 ft) (for Wiegand model only).
6. For optimum read range, use DC Linear power adaptor for the reader's power supply.
7. In order to ensure the reader's normal operation, input voltage should be $12V \pm 10\%$.
8. If the reader is installed in an open area or highly humid environment, it is recommended to protect the reader with an external shielding cover.
9. RS-485 communication baud rate is 9600.

6.5 Keypad

When using the reader, you can enter the door's Common Password or the card's PIN code on the keypad to gain access. The access mode is set in GV-ASManager (software).

- **0~9 Number Keys:** Press the number keys to enter a PIN code or password.
- **E Key:** Press the E key to confirm an entry.
- **C Key:** Press the C key to cancel an entry.

IMPORTANT: The Card and PIN Code mode requires users to enter the card's PIN code, press the E key to confirm the code, and then present the card to gain access.

6.6 LED Status and Beeper

The reader has the following LED status and beeper actions by default:

Condition	Wiegand	RS-485
Standby	Constant Red	No light
Access Denied	Beep once (No LED)	Flash Red momentarily + Beep three times
Access Granted	Beep once (No LED)	Flash Green momentarily + Beep twice

The reader includes external control wires for the Green LED and Beeper for Wiegand connection. You can change the default settings of the LED and Beeper by connecting these control wires to the GV-AS Controller.

6.7 Firmware Upgrade

GeoVision periodically updates its website with the latest firmware. Using the provided tool, the new firmware can be easily installed on the reader. For how to upgrade the firmware, see *3.7 Firmware Upgrade*.

6.8 Specifications

For details, please see the [datasheet](#).

For the number of readers supported by a variety of GeoVision controllers, see the [compatibility table](#).

Chapter 7 GV-R1354

The mini card reader GV-R1354, with only 8 cm tall, can be integrated into any standard access control systems through its Wiegand and RS-485 interfaces. Mini but complete, GV-R1354 has weather-sealed and IP56-compliant housing, perfect for both indoor and outdoor applications.

7.1 Packing List

1. GV-R1354
2. Data Cable

7.2 Compatible Products

- **GV-ASManager:** V5.3.3 or later
- **GV-AS Controllers:** GV-AS210 / 2110 / 2120, GV-AS810 / 8110 / 8111, GV-AS410 / 4110 / 4111, GV-AS1620

Note: To connect the reader to GV-AS Controllers *via RS-485*, it is required to use the following products and versions: GV-AS210 / 2110 / 2120 / 410 / 4110 / 4111 V2.40 (or later) and GV-AS1620 V1.04 (or later).

7.3 Physical Descriptions

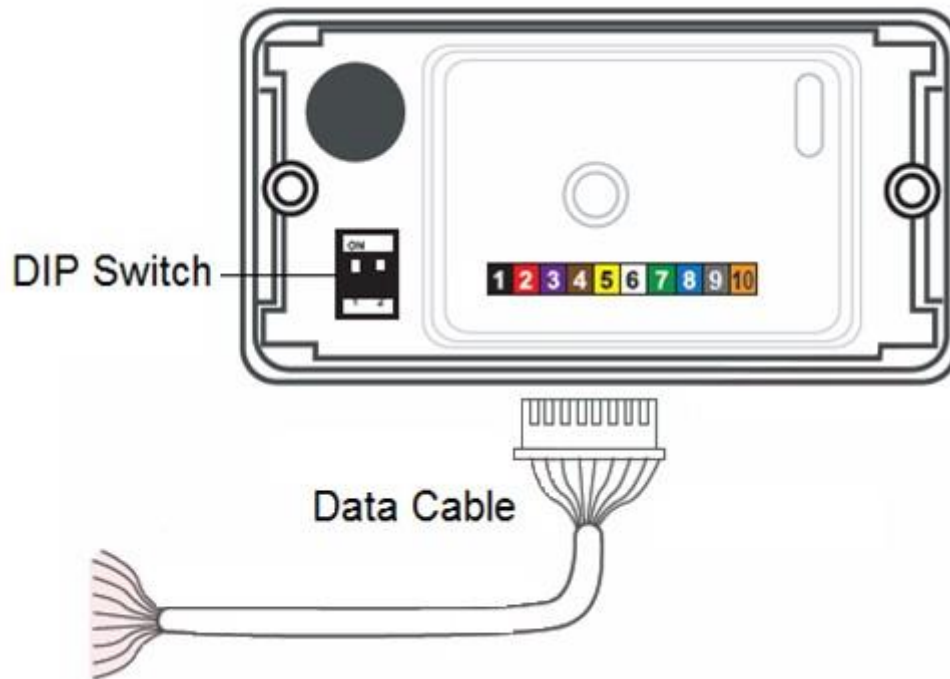

- **DIP Switch:** Used to set up card formats and communication signals. By default, the switch No. 1 is set to OFF for reading UID (Unique Identifier), and the switch No. 2 is set to ON for sending RS-485 and Wiegand signals simultaneously.

No.	Position	Description
1	ON	Read GID and DES-ID
	OFF (Default)	Read UID only
2	ON (Default)	Send both RS-485 and Wiegand signals
	OFF	Send RS-485 signals only

Note: Every time when the setting is changed, the reader needs to be restarted to apply the change.

- **Data Cable:** Connect the reader to GV-AS Controller based on the following pin definitions:

No	Wire Color	Description
1	Black	DC Power 0 V (GND)
2	Red	DC Power 12V
3	Purple	Beeper Input (Low Sound)
4	Brown	Green LED
5	Yellow	Red LED
6	White	N/A
7	Green	Wiegand Data 0
8	Blue	Wiegand Data 1
9	Gray	RS-485 (A+)
10	Orange	RS-485 (B-)

7.4 Installation

1. Using a self-prepared flat head screwdriver, pry apart the back cover from the enclosure's edge.
2. Connect the supplied Data Cable to the reader.
3. Secure the reader onto the wall with 2 self-prepared screws.

7.5 ID, Beeper and LED Settings

The **QR1352/ DES1352/R1354 Setup AP** allows you to set the reader's ID number, beeper and LED. The program can be downloaded from our [website](#).

A single RS-485 interface on the controller can connect up to 8 readers. In order for the controller to detect multiple connected readers, you must assign each one a unique ID number.

The reader will beep by default when a card approaches, *whether granted or rejected*. You can alter how the reader reacts when approached using the Setup AP, from a beep to a blinking red or green LED.

After downloading and installing the **QR1352/ DES1352/R1354 Setup AP** on a PC, first connect the reader to the PC using a *RS-485 to USB converter*, as illustrated below.

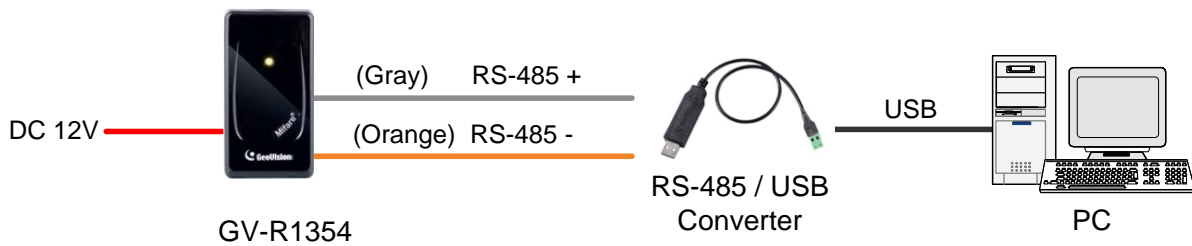

Note:

1. The ID setting is only required for the reader to be connected to a controller through RS-485.
 2. The beep and LED settings are applicable to both RS-485 and Wiegand readers.
-

1. Run the Setup AP.

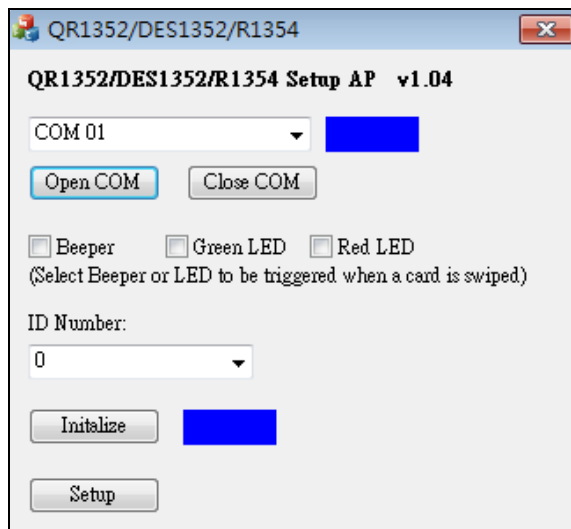

2. Select the **COM** port that is connected to the reader and click **Open COM**. A blue square should appear next to the COM port box to indicate the COM port selected is correct.
3. The beeper is enabled by default. To change the reader's reaction when approached, select **Beeper**, **Green LED** and/or **Red LED**. If you select both Beeper and Green LED, for example, when the reader is approached, it will beep together with a flashing green LED.
4. Only for a RS-485 reader, select an **ID number** for the reader. The ID number ranges from 0 to 7.
5. Click **Setup**. The settings are sent to the reader.
6. Connect another reader to the computer, and follow the instructions above for setup.

Note:

1. If the COM port is incorrect, an “**Error opening serial port**” message will appear. To verify the COM port connected to the reader, go to Windows Device Manager. In the Ports (COM & LPT) field, you should see the entry for **Prolific USB-to-Serial Comm Port** and the COM number currently in use.

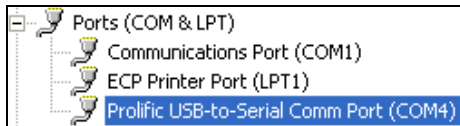

2. The reader has the following default access reactions. If you change default beep sounds to *green LED* using the Setup app, it will react as below:

For **RS-485** readers,

- One beep when a card approaches (default) → *Flashing green LED when a card approaches*
- Another one beep with green LED upon access granted
- Another two beeps with red LED upon access denied

For **Wiegand** readers,

- One beep upon access granted (default) → *Flashing green LED upon access granted*
 - One beep upon access denied (default) → *Flashing green LED upon access denied*
-

7.6 Firmware Upgrade

GeoVision periodically updates its website with the latest firmware. Using the provided tool, the new firmware can be easily installed on the reader.

First of all, prepare a RS-485 / USB converter, and connect the reader to a PC as illustrated in *7.5 Configure the ID, Beeper or LED*.

1. Download **Firmware Upgrade Tool** from our [website](#).

2. Run the Tool. This dialog box appears.



3. Select **Load FW (*ISP) File** to locate the firmware file.
4. Select **Upgrade Target (Program)** to start firmware upgrade.
5. When the firmware upgrade is complete, run the Setup App to initialize the reader.

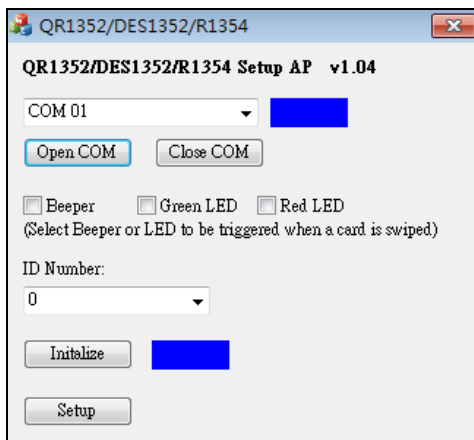

6. Select the COM port that is connected to the reader, and select **Open COM**.
7. Select **Initialize**. When the initialization is complete, a *Success* message will be displayed.

7.7 Specifications

For details, please see the [datasheet](#).

For the number of readers supported by a variety of GeoVision controllers, see the [compatibility table](#).

Chapter 8 GV-DFK1355

GV-DFK1355 is a keypad reader capable of reading PIN codes and access cards. It features a slim profile design, making it suitable for installation on a narrow door frame or in tight spaces. Thanks to its Wiegand and RS-485 interfaces, GV-DFK1355 can be connected to a variety of access control systems. With an ingress protection rating of IP66, the reader can be used in any environment.

Additionally, the GV-DFK1355 reader, which has two inputs (Exit Button and Door Sensor) and one output (Door Lock), can control a single door when combined with the GV-AS Bridge controller and the cloud-based software GV-Cloud Access Control.

8.1 Packing List

1. GV-DFK1355
2. Cable
3. Hex Key Wrench
4. Screw x 3
5. Quick Start Guide

8.2 Compatible Products

- **GV-ASManager** (software): V5.3.3 or later
- **GV-AS210 / 2110 / 2120, GV-AS810 / 8110 / 8111, GV-AS410 / 4110 / 4111** (controller): V2.41 or later (only Wiegand interface supported)
- **GV-AS1620** (controller): V1.05 or later
- **GV-CS1320** (controller): V3.10 or later

Cloud Integration

- **GV-Cloud Access Control** (cloud-based software): V1.00 or later
- **GV-AS Bridge** (controller): V1.00 or later

Note: To connect GV-DFK1355 to the cloud-based software GV-Cloud Access Control, GV-AS Bridge is required. See 8.8 GV-Cloud Access Control Integration.

8.3 Physical Descriptions

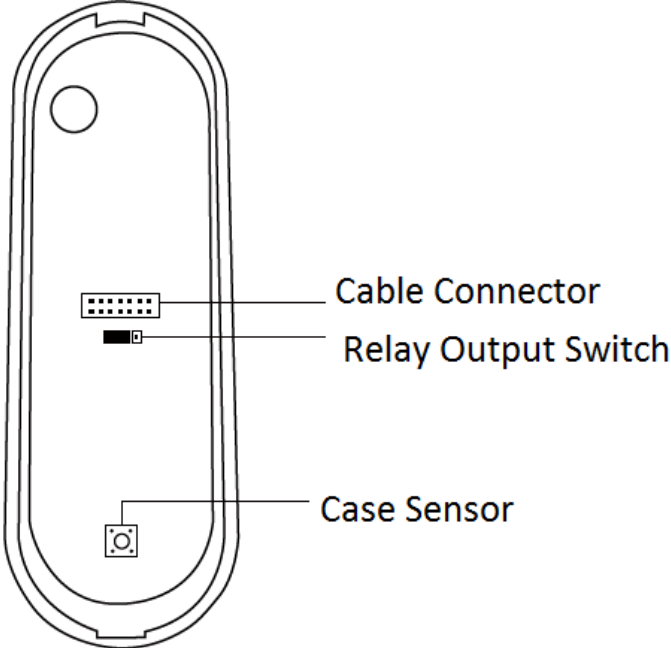

- **Cable Connector:** Connect the reader to the controller based on the following pin definitions:

Pin	Wire Color	Wiegand	RS-485
1	Red	DC 12V	DC 12V
2	Black	Ground	Ground
3	Yellow	-	RS-485+
4	Blue	-	RS-485-
5	Gray	-	Input 2 (Exit Button; NO)
6	Pink	-	Relay +
7	Orange & White		Relay -
8	Orange	-	Input 1 (Door Sensor; NC)
9	Brown	Green LED Control	-
10	Purple	Beep Control	-
11	White	Case Sensor GND (To Controller Input COM)	-
12	Green	Case Sensor (To Controller Temper Sensor)	-
13	Red & White	Wiegand Data 0	-
14	Gray & White	Wiegand Data 1	-

- **Built-in Relay**

The relay is set to NO (Normal Open) by default.



When Electric Bold Lock is used, connect wires to COM (Relay -) and NC (Relay +) contacts.
When Electric Strikes is used, connect wires to COM (Relay -) and NO (Relay +) contacts.

Note:

1. By default, **Input 1** (Door Sensor) is set to NC (Normal Closed) and **Input 2** (Exit Button) is set to NO (Normal Open), and neither of these settings cannot be changed.
2. The RS-485 interface supports either RS-485 or OSDP communication but not both at the same time.
3. If you want to switch from OSDP to Wiegand communication, you must first initialize the reader with the Firmware Upgrade Tool. For details on using the tool, see 3.7 *Firmware Upgrade*.



8.4 Installation

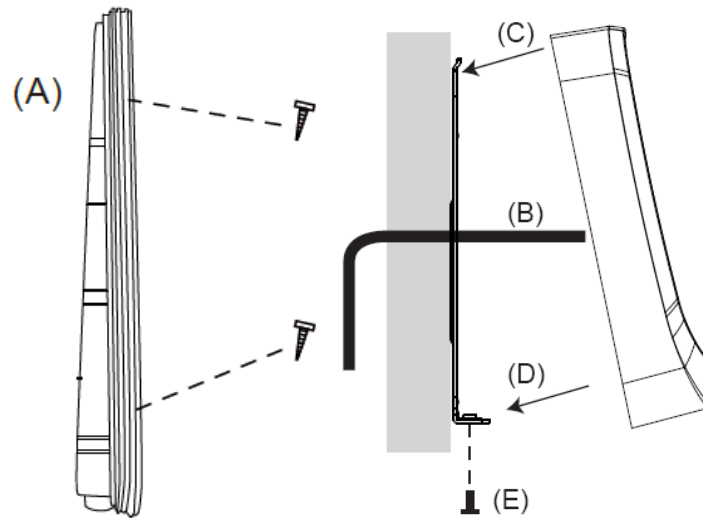

- A. Mount the backplate onto the wall or back box (US standard 120 type). Note DO NOT overtighten the backplate screws during installation to prevent distortion.
- B. Connect the wires in accordance with the **Writing Note** below.
- C. Make sure the backplate and the upper cover guide of the reader are aligned.
- D. Install the upper cover of the reader to the backplate.
- E. Fasten the screw onto the bottom of the reader.

Wiring Note:

1. Use minimum 22 AWG double-shielded aluminum mylar foil twisted pair cable for the connection between the reader and the controller.
2. In order to reduce long distance noise, the isolated net of transmission cable should connect to both ends of device ground.
3. The distance between two readers should be over 30 cm to prevent radio frequency interference from each other.
4. Mounting the reader around metal could affect read range. Metal of any type around the reader should be avoided while mounting.
5. The distance between the reader and the controller should not exceed 30 meters (98 ft) (for Wiegand model only).
6. For optimum read range, use DC Linear power adaptor for the reader's power supply.
7. In order to ensure the reader's normal operation, input voltage should be $12V \pm 10\%$.
8. If the reader is installed in an open area or highly humid environment, it is recommended to protect the reader with an external shielding cover.
9. RS-485 communication baud rate is 9600.

8.5 Keypad

When using the reader, you can enter the door's Common Password or the card's PIN code on the keypad to gain access. The access mode is set in GV-ASManager (software) or GV-Cloud Access Control (cloud-based software).

- **0~9 Number Keys:** Press the number keys to enter a PIN code or password.
- **# Key:** Press the # key to confirm an entry.
- *** Key:** Press the * key to cancel an entry.

IMPORTANT: The Card and PIN Code mode requires users to enter the card's PIN code, press the # key to confirm the code, and then present the card to gain access.

8.6 LED Status and Beeper

The reader has the following LED status and beeper actions by default:

Condition	Wiegand	RS-485
Standby	Constant Red	No light
Access Denied	Beep once (No LED)	Flash Red momentarily + Beep three times
Access Granted	Beep once (No LED)	Flash Green momentarily + Beep twice

The reader includes external control wires for the Green LED and Beeper for Wiegand connection. You can change the default settings of the LED and Beeper by connecting these control wires to the GV-AS Controller.

8.7 ID and Card Identifier Settings

The **DFK1355 Setup AP** allows you to set the reader's ID number and card identifier. The program can be downloaded from our [website](#).

A single RS-485 interface on the controller can connect up to 8 readers. For the controller to detect multiple connected readers, you must assign each one a unique ID number. The GV-DFK1355 reader can be integrated with cloud-based access control management by connecting to the RS-485 interface of the GV-AS Bridge controller; see *8.8 GV-Cloud Access Control Integration*.

The reader by default reads the UID (Unique Identifier) on access cards or key fobs. You can set the reader to read GID (GeoVision Identifier) or DES-ID instead.

After downloading and installing the **DFK1355 Setup AP** on a PC, first connect the reader to the PC using a *RS-485 to USB converter*, as illustrated below.

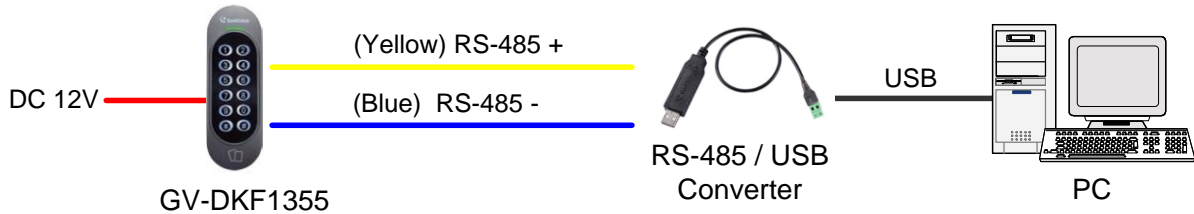

1. Run the Setup AP.

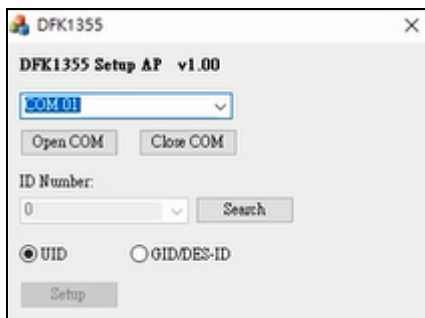

2. Select the **COM** port that is connected to the reader and click **Open COM**. A blue square should appear next to the COM port box to indicate the COM port selected is correct.
3. Select an **ID number** for the reader. The ID number ranges from 1 to 8.
4. Select **GID/DES-ID** to set the reader to read the card identifier of GID or DES-ID.
5. Click **Setup**.

Note: If the COM is incorrect, an *“Error opening serial port”* message will appear. To verify the COM port that is connected to the reader, go to Windows Device Manager. In the Ports (COM & LPT) field, you should see the entry for **Prolific USB-to-Serial Comm Port** and the COM number currently in use.

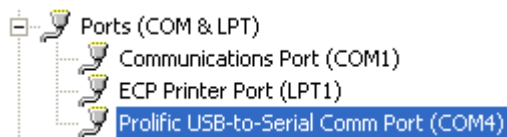

8.8 GV-Cloud Access Control Integration

The GV-DFK1355 reader, which has two inputs (Exit Button and Door Sensor) and one output (Door Lock), can control a single door when combined with the GV-AS Bridge controller and the cloud-based software GV-Cloud Access Control.

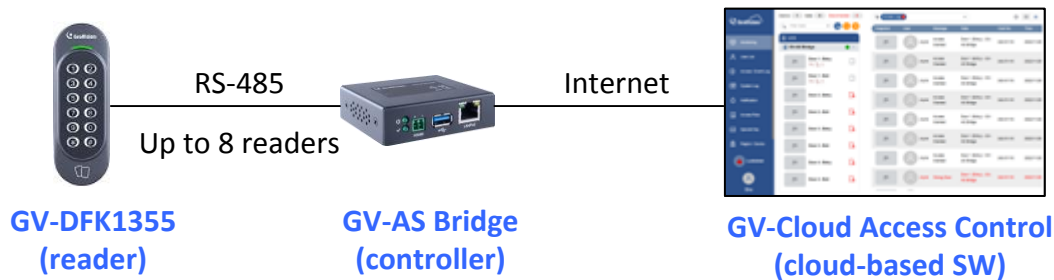

The RS-485 interface on GV-AS Bridge can support up to 8 readers. When connecting multiple readers, you must assign each one a unique ID so that GV-AS Bridge can recognize them. For how to configure the reader's ID, see *8.7 ID and Card Identifier Settings*.

Input 1 of the reader is for a Door Sensor with NC (Normal Closed) and **Input 2** is for an Exit Button with NO (Normal Open); neither of these settings can be changed. The reader's **Relay** is made for a Door Lock, and you can switch between NO and NC by using the reader's switch. See *8.3 Physical Descriptions*.

Note: Based on the connected output (Door Lock) on GV-DFK1355, only the door alarm statuses "Held Open", "Force Open", and "Lockdown" are available on GV-Cloud Access Control.

Force Open

- When "Force Open" is enabled on the reader, it will continue to beep, and the alarm status can only be cleared using GV-Cloud Access Control, or swipe a valid access card.

Held Open

- The "Held Open" alarm is generated when Held Open Time expires, which begins to countdown when the door lock is engaged but the door remains open.
- When the "Held Open" alarm is generated, the reader will continue to beep until the door is closed.
- The default values for Held Open Time and Lock Reset Time are 5 and 10 seconds respectively. You can alter the duration using GV-Cloud Access Control.

Lockdown

- When the door is forcibly locked down by GV-Cloud Access Control, you can open it by pressing the Exit button.
-

To connect to GV-AS Bridge:

1. Connect the RS-485 wires of the reader to GV-AS Bridge together.
2. On the GV-AS Bridge Web interface, select **Extended Reader Configuration**. This page appears.

Device Function

Devices DFK1355 AS210/AS410

Device IP Address 192 . 168 . 5 . 151

Login Name/Password Alvin123 / *****

ID	Serial Number	Output Function	Connection Status	Snapshot /Camera-ID /Connect Status CloudBridge IP:Port Login Name/Password
1	000000000001	Door/Gate 1 Entry	Enable	ID 0 192 . 168 . 5 . 225 : 80 admin / *****
2	000000000002	Door/Gate 1 Exit	Disable	ID 1 192 . 168 . 0 . 195 : 80 admin / *****

3. Select **DFK1355**.
4. Based on the Reader ID, specify each reader's output function, such as Door/Gate 1 Entry.
5. Click **Submit**. The green Connection Status indicates the successful connection.

For details, see 1.6.3 *Extended Device, GV-AS Bridge Installation Guide*.

8.9 Firmware Upgrade

GeoVision periodically updates its website with the latest firmware. Using the provided tool, the new firmware can be easily installed on the reader. For how to upgrade the firmware, see *3.7 Firmware Upgrade*.

8.10 Specifications

For details, please see the [datasheet](#).

For the number of readers supported by a variety of GeoVision controllers, see the [compatibility table](#).

Appendix

What to do if RS-485 connection fails?

When a reader successfully connects to GV-AS Controller via RS-485, the Controller's Web interface should show a green tick under Connection Status, and the reader's LED should switch off from a continuous red.

Extended Reader Configuration

GV-Reader/CR1320/GF192x/QR1352/DES1352 Function

If the Ex-Reader is connected to GV-AS Controller through Ethernet, do not select the checkbox below.

RS485 Protocol GV OSDP QR1352/DES1352

OSDP Speed/Baudrate

RS485	ID	Serial Number	Function	Connection Status
<input checked="" type="checkbox"/>	0	<input type="text" value="000000000001"/>	<input type="text" value="Door/Gate A Entry"/>	
<input checked="" type="checkbox"/>	1	<input type="text" value="000000000002"/>	<input type="text" value="Door/Gate A Exit"/>	●

ASManager IP Address: : (from 1025 to 65535)

If the reader's LED remains red and there is no successful connection status on the Web interface, try adding a **180 Ohms terminal resistor** on the RS-485 terminal block of the reader to extend the range of data communication.

