

5900

Power Supply / Charger

Description

The 5900 series of power supply/charger supplies a total of 6 amp nominal continuous supply current @ 12/24VDC outputs. It is installed in a large sheet steel enclosure capable of accommodating one or two 12AH lead acid rechargeable batteries. The power supply model: 5900 have been evaluated for: CAN/ULC-S527,UL864,ULC-S318,UL603,UL294,CAN/ULC-60839-11-1, CAN/ULC-S533.The above Power supplies are not intended to power Fire Notification Appliances(Horns,Strobes & Bells).

General Specifications:

1. Input = 120-240VAC 50-60Hz, 2.5 Amp maximum, fuse at 6 Amp
2. Output 6 Amps continuous supply current PF 0.6 at nominal 12/24 VDC.
3. Built-in dedicated charger for sealed lead acid or gel cell type batteries.
4. Maximum battery charging current 1.5Amps (not part of the max output current rating).
5. Automatic switch over to stand-by battery upon AC failure or below 72.5VAC.
6. Battery presence detection within 10 seconds.
7. Temperature Compensated Battery Charger.(EN54-4 only,not UL evaluated)
8. Battery Charger Monitor.
9. Battery load test every 48hr.
10. Battery test result indication.
11. Battery Reversal protection.
12. Low Battery indication at 11.40/22.80 Volts.
13. Low Battery disconnect at 10/20.2 Volts.
14. Low Battery, Battery disconnect, No Battery presence, battery charger trouble reporting. (See FAULT TABLE)
15. AC input indication by Green LED. (LED on when AC is present).
16. AC Fault CMOS Relay contact for AC failure
17. LEDs display on enclosure door (Green, Yellow, Blue).
18. DC output indication by Blue LED, on board and enclosure.
19. Overload and short circuit protection on DC output.
20. Battery charging leads included.
- 21 Board Dimension: 195mm x 110mm
22. Enclosure Dimension: 338 x 448 x 110mm

Technical Specification:

Output Voltage Output Amperage Ripple	12/24 Vdc Regulated. Class E, unsupervised 6 Amp 50 mVp-p max
Charging Current Battery Charging Voltage	1.5A Max, and not part of max output rating 13.8V/27.6V Nominal
Operating Temperature	0deg.C to 49deg.C

Performance Ratings

UL 294 Performance Levels:

Model	Product Type	Line Security	Destructive Attack	Endurance	Standby Power
5900	Power Supply	I	I	IV	III (when used with 12Ah battery "output is limited to maximum 4 Amps"

CAN/ULC-60839-11-1 Performance Grades:

Model	Product Type	Grade	Grade Achievement
5900	Power Supply	3 (when used with 12Ah battery) "output is limited to maximum 4 Amps"	Connect AC & Battery Trouble Outputs to a Grade 3 Control Unit, to achieve Grade 3.

LED Indications

1. Green LED - AC indicator

- a. On when AC present.
- b. The AC fail Relay activates (opens) within 60 seconds after AC failure.

2. Blue LED – DC Power indicator

- a. Powered directly from the power supply DC output and indicates output is present.

3. Yellow LED – Battery Charging and Fault indicator

- a. The Yellow LED flashing indicates the battery is charging and is also used to indicate various Fault conditions. See the Fault Condition and Indication Table for details.

4. Red LED –Battery/Charger test Indicator for Pass or Failure.

- a. The Red LED indicates a Battery test Failure or a Battery charger failure in conjunction with the Yellow LED to indicate other Fault Conditions. See the Fault Conditions and Indication Table for details.

Relay Outputs:

Output	Output Type	Description
AC FAIL	NORMALLY CLOSED OPEN = FAULT	TRIPS WITHIN 60 SEC. AFTER AC FAILS CMOS RELAY RATING: 30VDC 60mA 16 OHMS
BATTERY FAIL	NORMALLY CLOSED OPEN = FAULT	BATTERY PROBLEM CMOS RELAY RATING: 30VDC 60mA 16 OHMS

Fault Condition & Indications:

FAULT	LED-G	LED-Y	LED-R	BATT RELAY	AC RELAY	LED-B
BATTERY REVERSED OR NOT CONNECTED		ON		OPEN		
BATTERY LOW		ON		OPEN		
BATTERY DISCONNECTED		ON		OPEN		
BATTERY TEST FAIL		ON	5 RAPID FLASHES STOP 1 SECOND REPEAT UNTIL BATTERY IS REPLACED	OPEN		
BATTERY TEST OK		OFF	3 FLASHES 1 SEC ON/OFF			
CHARGER FAIL			10 RAPID FLASHES 2 SECONDS STOP AND REPEAT UNTIL OK	OPEN		
AC FAIL	OFF				OPEN WITHIN 60 SEC	
DC FAIL/OVERLOAD						OFF

Battery Operating Values

Parameter	Output	Description
Battery Disconnect voltage	10/20.2V	When AC is off, the battery is disconnected when the battery voltage drops below this value. The battery is only reconnected when the AC is restored.
Minimum battery voltage to pass battery test	11.50V 23.0V	Red Led Flash 1 sec ON/OFF during 2 minutes testing. Battery Fail 5 rapid flashes and 1 sec pause. Replace Battery
Low Battery Voltage Warning	11.40V 22.80V	If the output voltage drops below this value a voltage low warning is generated. See Fault Conditions and Indication table.

Installation Instructions

This power supply should be installed in compliance with National Electrical Code, NFPA70 as well NFPA72 National Fire Alarm Code, CSA C22.1, Safety Standard for Electrical Installations, Canadian Electrical Code, Part I, CAN/ULC-S524, and all applicable Local Codes. Installation to be performed by suitably qualified personnel. The power supply shall not be installed in the fail secure mode unless permitted by the local authority having jurisdiction, and shall not interfere with the operation of Listed panic hardware.

- 1 Mount the power supply in the desired location using the 4 mounting holes.
**NOTE: For use in Indoor Protected Area with Controlled Environment only.
Do not Install Power Supply on Exterior Doors.**
- 2 With the Mains power disconnected, connect the leads to the AC Input Terminal Block, respecting the wiring phase and polarity :
Ground/Earth=Green/Yellow, Neutral = Blue (White), Live =Black (Brown). This equipment must be connected to the 120-240 Volt Mains via a readily dedicated accessible external disconnect device with maximum 15 Amp branch protection. Select the operating output DC voltage 12/24 with the jumper SW1. SW1 ON=12VDC, SW1 OFF=24VDC.
- 3 **Do not connect the battery at this time.**
- 4 Switch ON the AC. Green LED will come ON indicating AC is present and the AC Fault Relay will be energized "ON" (closed). When the AC is off the AC Fault Relay will drop open within 60 seconds (Factory set) activating the CMOS output contact "AC Fail". Connect this output to relevant monitoring devices.
- 5 Verify the DC output voltage is correct = 13.20VDC or 26.40VDC max. Blue DC LED will be ON to indicate DC output is OK.
- 6 Yellow LED will be on and the BAT FAULT CMOS relay open indicating the Battery is not present or connected with reversed polarity.
- 7 Connect the Battery or Batteries respecting the polarity. Battery shall not be connected if AC is not present first.
- 8 If the battery is connected with the correct polarities the Yellow LED will turn OFF (See Fault Conditions and Indications Table). Within one minute the Battery Fault Relay will restore and the Yellow LED will flash once every 2 seconds.
- 9 If the battery is connected reverse polarity, the Yellow LED will be ON. (See the Table Fault). The CMOS relay will open indicating Battery Fault. Connect this output to relevant monitoring devices.
- 10 Connect the devices to be powered to the output terminals marked "Vo- Vo+".
- 11 If Tamper Switch is required use part # TS1 or TS2, see Fig 3.
- 12 Use 2K2 EOLR (end of line resistor) Part #500347
- 13 Connect the fault relays to FACP or ACP for trouble indication.
- 14 Secure the enclosure with the Key Lock if provided.

5900

REGULATED POWER SUPPLY CHARGER
UL/ULC LISTED AS FOLLOWS:

UL294, CAN/ULC-60839-11-1, CAN/ULC-S533 FOR ACCESS CONTROL SYSTEM
UL864, CAN/ULC-S527 FOR COMMERCIAL FIRE
UL603, ULC-S318 FOR BURGLARY ALARM SYSTEM

NOTE: PLEASE REFER TO 5900 INSTALLATION MANUAL, PART NO:M5900 REV:01



Date of MFG



REG# T1880475-02



REG# T1880475-01



REG# T1880475-03

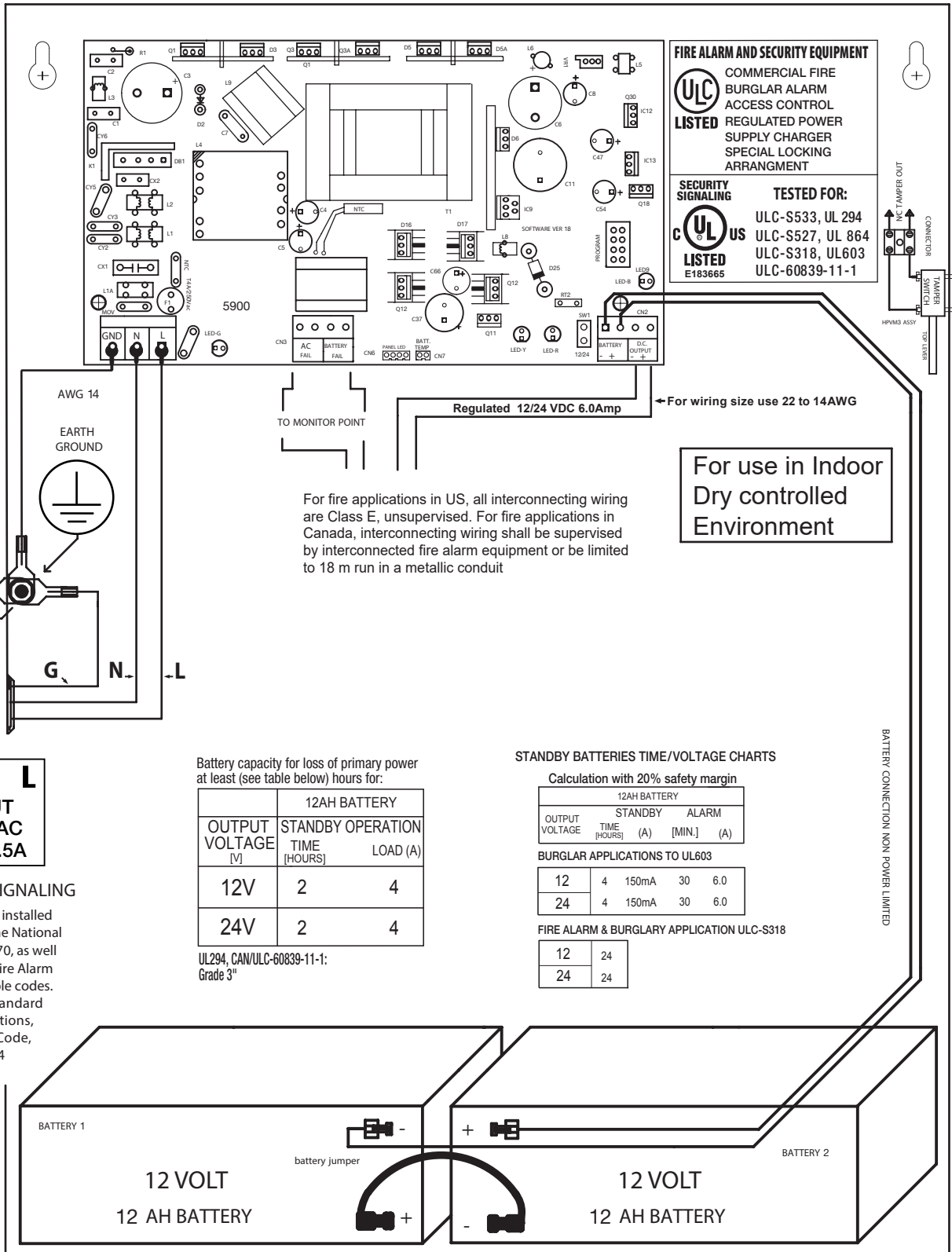

FIRE ALARM AND SECURITY EQUIPMENT
ULC LISTED COMMERCIAL FIRE
 BURGLAR ALARM
 ACCESS CONTROL
 REGULATED POWER
 SUPPLY CHARGER
 SPECIAL LOCKING
 ARRANGMENT

SECURITY SIGNALING **TESTED FOR:**
ULC LISTED ULC-S533, UL 294
 E183665 ULC-S527, UL 864
 ULC-S318, UL603
 ULC-60839-11-1

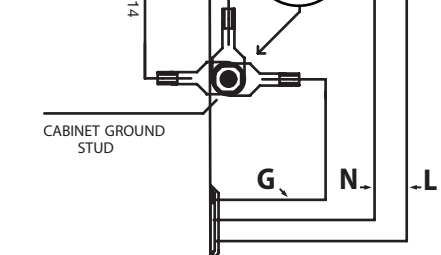
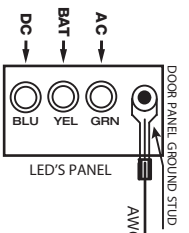

For use in Indoor
Dry controlled
Environment

For fire applications in US, all interconnecting wiring are Class E, unsupervised. For fire applications in Canada, interconnecting wiring shall be supervised by interconnected fire alarm equipment or be limited to 18 m run in a metallic conduit

G N L
AC INPUT
120-240 VAC
50-60Hz 2.5A

FIRE PROTECTIVE SIGNALING

This Product must be installed in compliance with the National Electrical Code NFPA70, as well as NFPA72 Nation a Fire Alarm Code and all applicable codes. CSA C22.1, Safety Standard for Electrical Installations, Canadian Electrical Code, Part I, CAN/ULC-S524

Battery capacity for loss of primary power at least (see table below) hours for:

OUTPUT VOLTAGE [V]	12AH BATTERY	
	STANDBY OPERATION TIME [HOURS]	LOAD (A)
12V	2	4
24V	2	4

UL294, CAN/ULC-60839-11-1: Grade 3"

STANDBY BATTERIES TIME/VOLTAGE CHARTS

Calculation with 20% safety margin

12AH BATTERY		STANDBY		ALARM	
OUTPUT VOLTAGE	TIME [HOURS]	(A)	[MIN.]	(A)	(A)
12	4	150mA	30	6.0	
24	4	150mA	30	6.0	

BURGLARY APPLICATIONS TO UL603

12	4	150mA	30	6.0
24	4	150mA	30	6.0

FIRE ALARM & BURGLARY APPLICATION ULC-S318

12	24
24	24

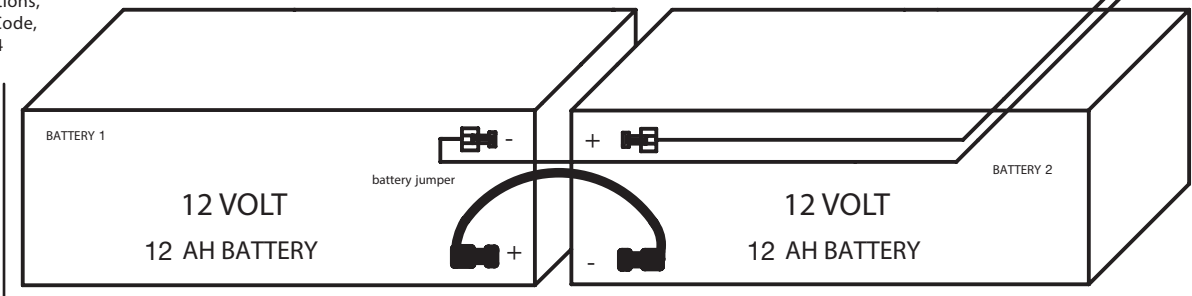

KEEP POWER LIMITED WIRING FROM NON POWER LIMITED WIRING AT LEAST 0.25" INCH APART

Optional Tamper Switch Connection

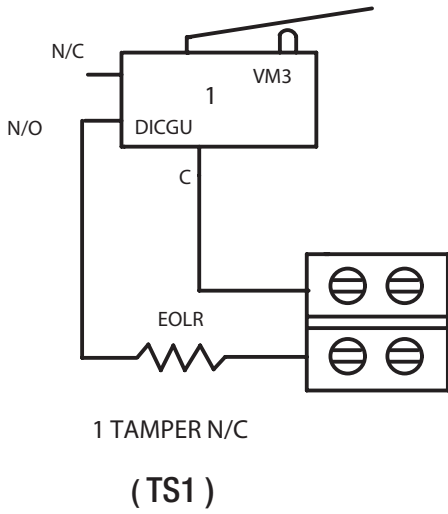

CONNECT TO MONITORING POINT

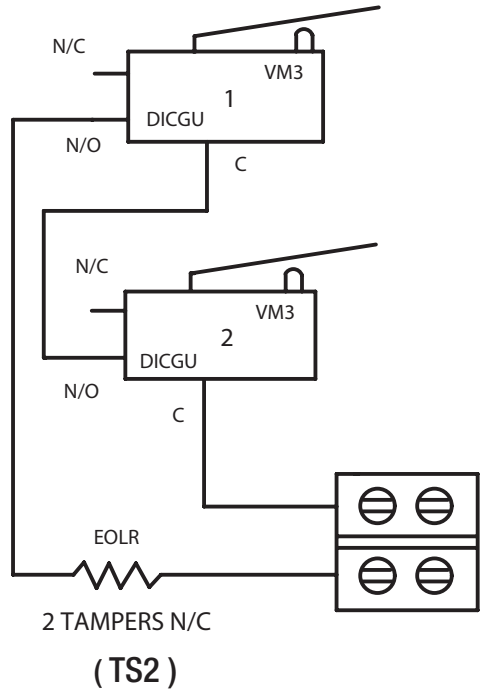

CONNECT TO MONITORING POINT

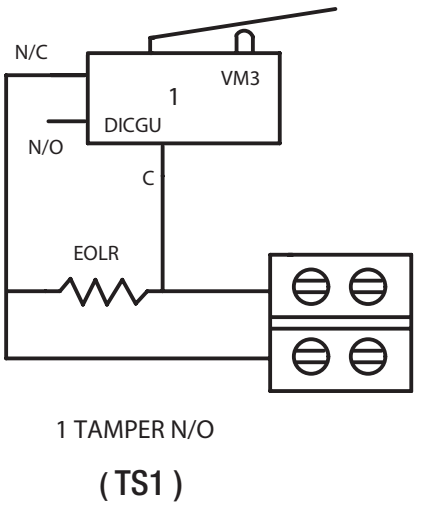

CONNECT TO MONITORING POINT

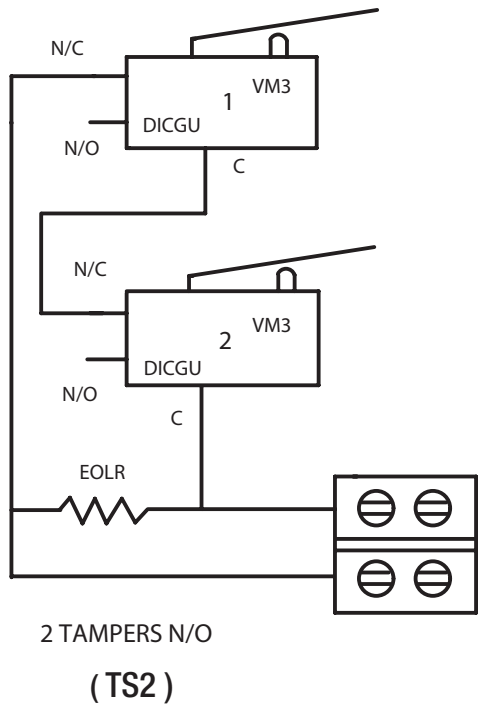

CONNECT TO MONITORING POINT

Fig. 3