

# Conettix D6200



EN

Operation and Installation Guide  
Programming/Administration  
Software



**BOSCH**

# Contents

<b>1.0</b>	<b>Getting Started.....</b>	<b>3</b>	3.12	Language and Help Menus.....	50
1.1	Network Communications.....	3	3.12.1	Language Menu.....	50
<b>2.0</b>	<b>Installation.....</b>	<b>5</b>	3.12.2	Help Menu.....	50
2.1	Installing the D6200 Application.....	5	<b>4.0</b>	<b>Upgrading the Software .....</b>	<b>51</b>
2.2	Installing Sentinel Protection Server.....	6	4.1	Performing a One-Button Upgrade.....	51
2.2.1	General Information.....	6	4.2	Line Card Firmware Setup (D6600 only) ...	52
2.2.2	Supported Platforms.....	6	4.3	Manual Upgrade Wizard.....	53
2.2.3	Installation Procedure.....	6	4.4	Backing Up the D6600/D6100IPv6 Configuration and Database Files.....	54
2.2.4	Verifying Sentinel Protection Server Operation.....	8	4.4.1	CPU/Network Configuration.....	54
<b>3.0</b>	<b>Operation.....</b>	<b>9</b>	4.4.2	Line Configuration.....	54
3.1	Log On.....	9	4.4.3	Caller ID Database (D6600 Only).....	54
3.2	Environment Option.....	9	4.4.4	DNIS Database (D6600 Only).....	54
3.3	Connection Settings.....	10	4.4.5	Network Account Database.....	55
3.3.1	RS-232 Connection.....	10	4.5	Manually Upgrading the CPU Firmware.....	55
3.3.2	Network Connection.....	10	4.6	Reloading the Configuration File.....	55
3.3.3	Password Protection.....	12	4.6.1	CPU Configuration File.....	55
3.4	D6200 Icon Bar.....	13	4.6.2	Line Configuration File.....	55
3.5	D6200 Administration.....	14	4.6.3	Caller ID Database Configuration File (D6600 Only).....	56
3.5.1	User Management.....	14	4.6.4	DNIS Database Configuration File (D6600 Only).....	56
3.5.2	Changing User Password.....	15	4.6.5	Network Account Database Configuration File .....	56
3.5.3	Environment Option.....	15	4.7	Upgrading the D6640 Line Card Firmware (v01.xx.xx).....	56
3.6	TeleCom Configuration.....	16	4.8	Upgrading the D6640 Line Card Firmware (v02.xx.xx).....	56
3.6.1	CPU Configuration.....	16	4.9	Upgrading the D6x41 Line Card Firmware.....	57
3.6.2	Line Card Configuration.....	17	4.10	Upgrading the D6600 System Files.....	57
3.6.3	Default Line Configuration from D6200 Software.....	19	<b>5.0</b>	<b>Troubleshooting.....</b>	<b>58</b>
3.6.4	Copying Selected Line Configuration from D6200 Software.....	20	5.1	Uninstalling the D6200 Software.....	58
3.7	Network Configuration.....	21	5.2	Assigning IP Addresses Using Telnet.....	58
3.7.1	Opening the Configuration File.....	21	5.2.1	Initial Assignment of the IP Address Using ARP.....	58
3.7.2	Reading the Configuration File.....	21	5.2.2	Using Telnet to Complete the IP Address Configuration.....	59
3.7.3	Editing the Configuration File.....	21	5.3	Using the Ping Utility.....	60
3.7.4	Sending the Configuration File.....	22	<b>6.0</b>	<b>Specifications.....</b>	<b>61</b>
3.8	Databases.....	22			
3.8.1	Caller ID (D6600 Only).....	22			
3.8.2	DNIS (D6600 Only).....	24			
3.8.3	Network Accounts.....	26			
3.8.4	Modifiting individual accounts.....	36			
3.8.5	Searching for Account.....	37			
3.8.6	C900 Commands.....	38			
3.9	Network Utilities.....	43			
3.9.1	Show Account Status.....	43			
3.9.2	Network Device Setup.....	43			
3.10	System Management.....	45			
3.10.1	Event Database.....	46			
3.10.2	Date/Time Synchronizations.....	48			
3.10.3	Firmware Version.....	48			
3.11	Firmware Utilities.....	49			
3.11.1	One Button Backup.....	49			
3.11.2	One Button Restore.....	49			
3.11.3	One Button Tech Support.....	49			

## Trademarks

Trademark names are used throughout this document. In most cases, these designations are claimed as trademarks or registered trademarks in one or more countries by their respective owners. Rather than placing a trademark symbol in every occurrence of a trademark name, Bosch Security Systems, Inc. (hereinafter referred to as Bosch) uses the names only in an editorial fashion and to the benefit of the trademark owner with no intention of infringing the trademark.

Microsoft, Windows, Windows Vista, and Windows 7 are either registered trademarks or trademarks of Microsoft Corporation in the United States and/or other countries.

## Action Icon Legend



Double-click the left mouse button.



Click the left mouse button once.



Click and hold the left mouse button, then drag the mouse.



Click the right mouse button once.



Press a key.

## 1.0 Getting Started

### 1.1 Network Communications

The Conetix D6600/D6100IPv6 Communications Receiver/Gateway system supports data network communications. This allows the receiver to connect to Ethernet networks, and process messages both to and from most networks in user datagram protocol (UDP) or internet protocol (IP). For a D6600, use a COM4 or a COM1 connection to connect to the D6686, D6682, or D6680 network adapter. For the D6100IPv6, it includes the Ethernet adapter port. Reports from alarm control panels on the public switched telephone network (PSTN), or another data network, can be sent to the central station automation software through a local-area network (LAN) or wide-area network (WAN). Alarm control panels' status and connections can be monitored over the network. Update or upgrade the receivers through the network connection. Remotely program the receivers through the D6200 software. Refer to the following documents about network communications and their installation requirements.

- *D9133TTL-E Installation Guide* (P/N: 4998122717)
- *Conetix C900V2 Installation Guide* (P/N: F01U003472)
- *C900TTL-E Installation Guide* (P/N: 4998122718)
- *Conetix DX4020 Installation Guide* (P/N: F01U045288)
- *Conetix D6680 Network Adapter Installation Guide* (P/N: 4998138732)
- *Conetix D6682 Ethernet Network Adapter Installation Guide* (P/N: F01U078049)
- *DeviceInstaller Operation and Installation Guide* (P/N: 4998138688)
- *D6682 Installation Guide* (P/N: F01U078049)
- *D6686 Installation Guide* (P/N: F01U269888)
- *ITS-DX4020-G Installation and Operation Guide* (P/N: F01U133268)
- *B420 Ethernet Communication Module Installation and Operation Guide* (P/N :F01U215236)
- *B426 Ethernet Communication Module Installation and Operation Guide* (P/N : F01U266226)

**Figure 1: Conettix D6600/D6100IPv6 System Connection Diagram: C900V2/C900TTL-E and any Control Panel**

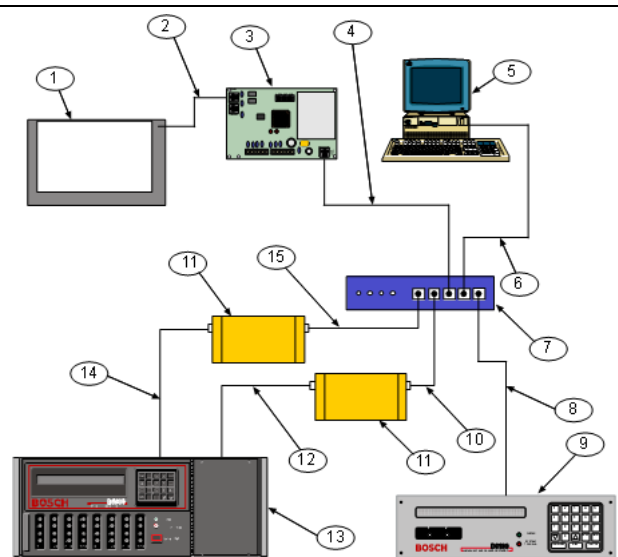

- 1 - Any manufacturer's control panel
- 2 - Connection - Control panel telco jack to C900V2/C900TTL-E jack
- 3 - C900V2/C900TTL-E Dialer Capture Module
- 4 - Connection - C900V2/C900TTL-E Ethernet jack to Ethernet switch/hub
- 5 - Host PC running D6200 Programming Administrative Software
- 6 - Connection - Host PC network interface card (NIC) to Ethernet switch/hub
- 7 - Ethernet switch/hub
- 8 - Connection - Ethernet switch/hub to D6100IPv6/D6100i
- 9 - D6100IPv6/D6100i
- 10 - Connection - Ethernet switch/hub to D6686/D6682/D6680
- 11 - D6686/D6682/D6680
- 12 - Connection - D6686/D6682/D6680 to D6600 COM4 port
- 13 - D6600

**Figure 2: Conettix D6600/D6100IPv6 System Connection Diagram: B426/B420/DX4020 and Bosch Control Panels**

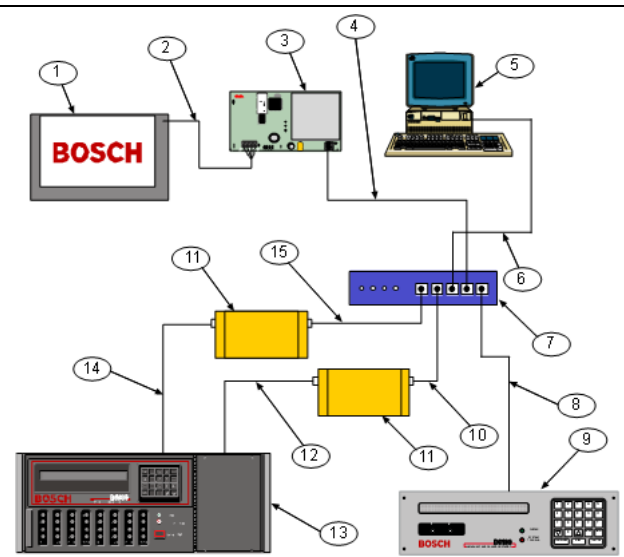

- 1 - Bosch Control Panels
- 2 - Connection - Control panel serial device interface (SDI2/SDI/Option) bus to B426/B420/DX4020 Terminals
- 3 - B426/B420/DX4020 Network Interface Module
- 4 - Connection - B426/B420/DX4020 Ethernet port to Ethernet switch/hub
- 5 - Host PC running D6200 Programming Administrative Software
- 6 - Connection - Ethernet switch/hub to Host PC NIC
- 7 - Ethernet switch/hub
- 8 - Connection - Ethernet switch/hub to D6100IPv6/D6100i
- 9 - D6100IPv6/D6100i
- 10 - Connection - Ethernet switch/hub to D6686/D6682/D6680
- 11 - D6686/D6682/D6680
- 12 - Connection - D6686/D6682/D6680 to D6600 COM4 port
- 13 - D6600

**Figure 3: Conettix D6600/D6100IPv6 System Connection Diagram: ITS-DX4020-G and Bosch Control Panels**

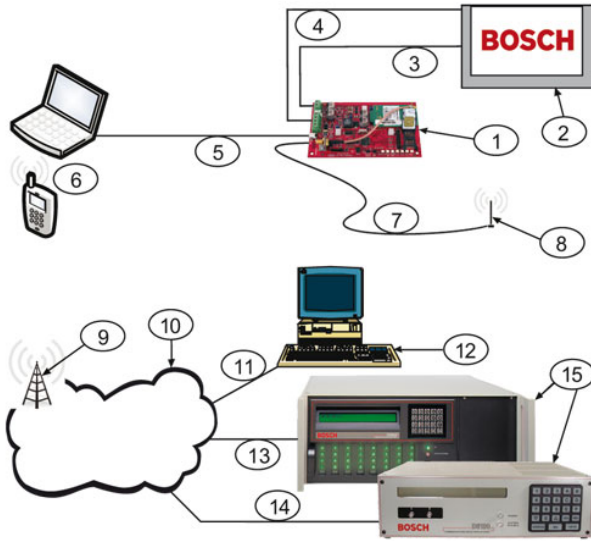

- 1 – ITS-DX4020-G GPRS/GSM Communicator
- 2 – Compatible Control Panel
- 3 – Control Panel Dialer Connection (optional)
- 4 – Control Panel Bus and Power Connection
- 5 – USB Type A (host)-to-USB Mini B (device) Cable (not included)
- 6 – Local PC or SMS-capable Cell Phone for Configuration
- 7 – Antenna Cable
- 8 – Magnetic Base Antenna
- 9 – Base Station on Wireless Carrier's Network
- 10 – Internet, WAN, Ethernet, or PSTN network
- 11 – Remote PC's Network Connection
- 12 – Remote PC Running Remote Programming Software (RPS)
- 13 – Ethernet Connection
- 14 – PSTN Connection
- 15 – Conettix D6600 or Conettix D6100IPv6/D6100i Receiver

## 2.0 Installation

### 2.1 Installing the D6200 Application



In a network configuration, if both the D6200 and D6202 are installed on the same PC, you can run only one application at a time unless you are using a different listen port number for each application.



Save and back up the different databases (Network Account, Dialed Number Identification Service (DNIS), and Caller ID) and configurations (CPU, Line, and Network) after installing the software. Load these files back into the receiver.



The D6200 version number shown in these steps are for example only. Your version may be different.

1. Insert the D6200 CD-ROM.

- 2.

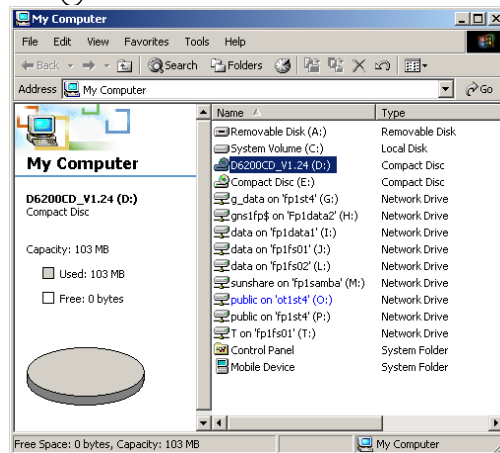

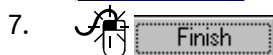
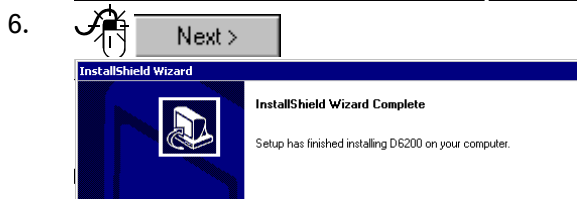
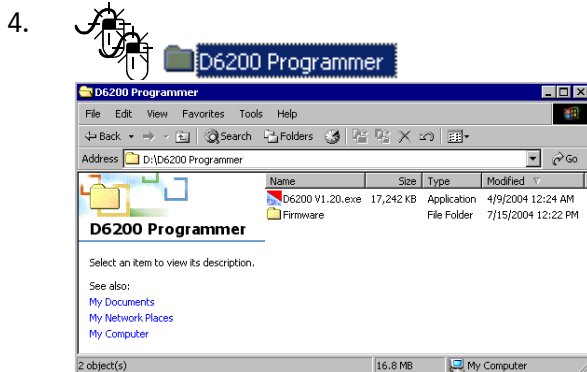
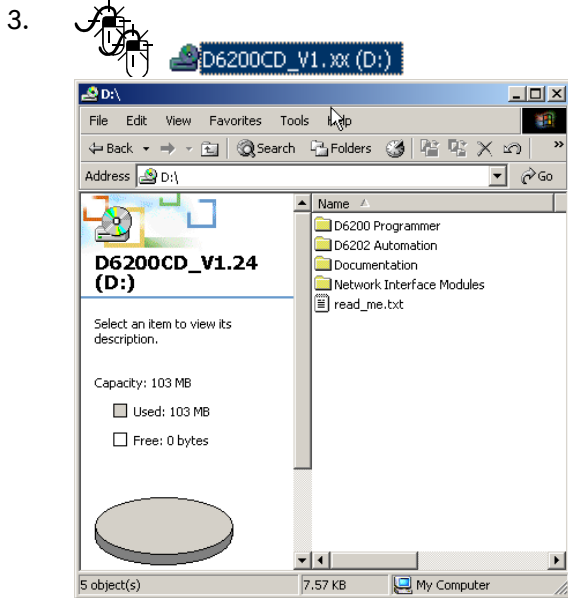

## 2.2 Installing Sentinel Protection Server

### 2.2.1 General Information

Sentinel Protection Server has been enhanced with the D6200 Version 1.24 or higher.

When installed in a networked environment, the D6200 application uses the Sentinel Protection Server software to access the D6201 and D6201-USB series security keys. This new feature enables multiple D6200 workstations on a LAN to open the network account database using a single security key. Each workstation can access a network account database that has up to 3200 accounts without having a security key attached to the workstation. This is possible only if at least one workstation or Windows file server on the LAN has the D6200 software and the D6201 and D6201-USB series security key installed. Previously, each D6200 workstation required its own D6201 and D6201-USB Security Key to enable full access to the network account database.



Without a security key installed you can send and receive only 10 network accounts from the receiver.



If an earlier version of Sentinel Protection Server is already installed, and you have upgraded to Windows 2000, XP, Vista, or Windows 7, you must first uninstall the Sentinel Protection Server using its setup.exe application.

Do not uninstall using the Add/Remove Programs option in Control Panel.



You must have Administrator privileges to install the Sentinel Protection Server.

### 2.2.2 Supported Platforms

Sentinel Protection Server requires a version of Microsoft Windows XP, Vista, Windows 7 or Windows 8. If you do not have one of these operating systems, the Sentinel Protection Server does not install, and you must either purchase additional keys for each workstation, or upgrade your operating system.

### 2.2.3 Installation Procedure



You must install the D6200 (V1.24 or higher) on every networked workstation requiring D6200 operation. You do not need to install a security key on more than one workstation on your network, but you might want to install additional security keys to prevent a communications loss resulting from a failed workstation.

Sentinel Protection Server is installed or upgraded as part of the normal D6200 installation process. Refer to *Section 2.1 Installing the D6200 Application* on page 5. When the D6200 installation process completes, the Sentinel Protection Server installation begins automatically.

1. The Sentinel Protection Installer window opens.

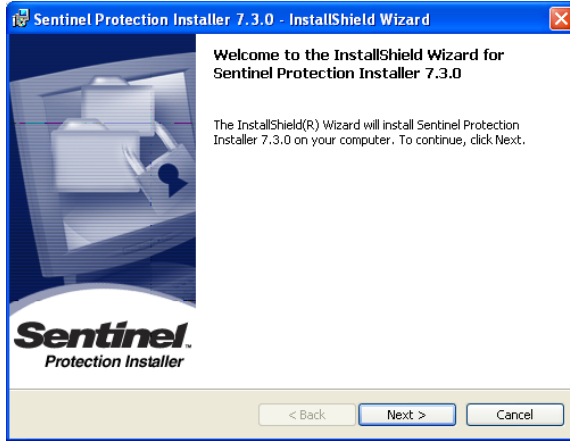
 **Next >.**



2.  I accept the terms in the license agreement, then  **Next >.**

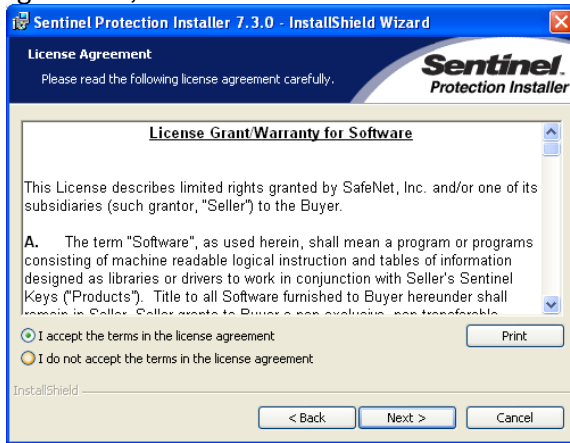

3.  **Complete, then**  **Next >.**

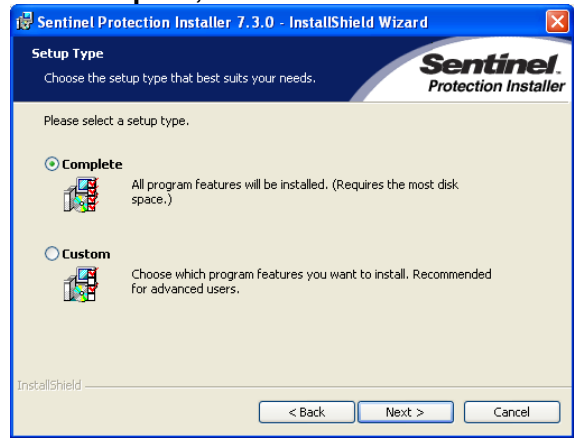

4.  **Install.**

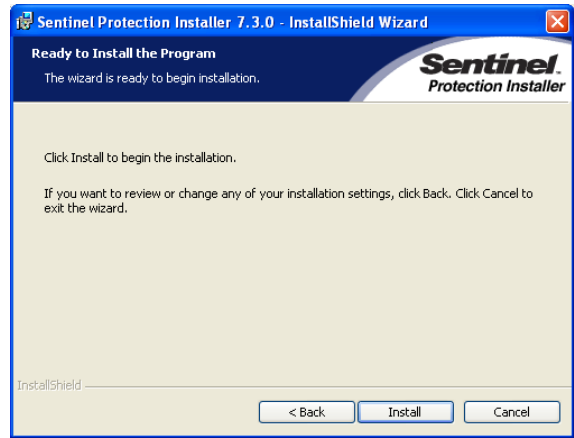

- If you are installing the D6200 software on a PC with Windows XP SP2 or later, the following screen appears.



**Yes.**



The Sentinel Protection Server software installs.

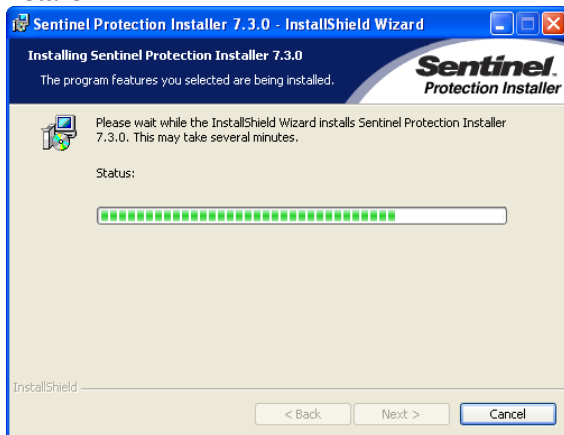

- When the installation finishes, **Finish.**



## 2.2.4 Verifying Sentinel Protection Server Operation

- Start**, then **Run...**
- Type **services.msc**, then **OK**. The Services window opens.

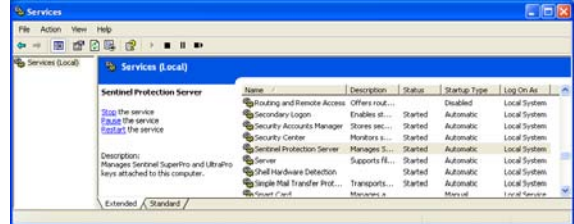

- Scroll to the Sentinel Protection Server entry, and confirm that the status is **Started**.

Name	Description	Status
Routing and Remote Access	Offers rout...	Disabled
Secondary Logon	Enables st...	Started
Security Accounts Manager	Stores sec...	Started
Security Center	Monitors s...	Started
Sentinel Protection Server	Manages S...	Started
Server	Supports fil...	Started
Shell Hardware Detection	Shell Hardware Detection	Started
Simple Mail Transfer Prot...	Transports...	Started
Smart Card	Manages a	Manual

If the status is blank, Sentinel Protection Server and select **Start**.

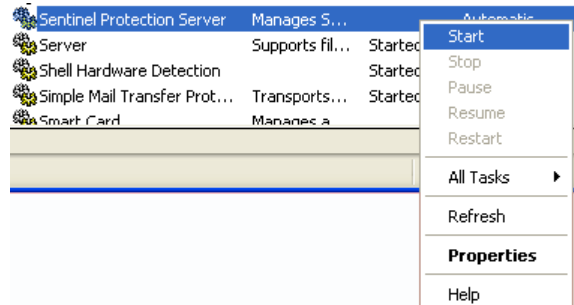

If the status is **Paused**, Sentinel Protection Server and select **Resume**.

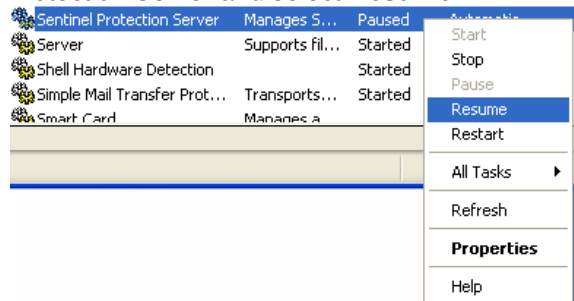



### 3.0 Operation

The D6200 allows the user to view, change, upload and download all of the D6600 or D6100IPv6/D6100i programming parameters over a network or the receiver's and the host's serial COM ports. Through the D6200 software, the user can:

- edit CPU and line card parameters,
- view the status of all accounts in the databases,
- add, edit, or delete accounts, and
- configure network operations.

The D6600/D6100IPv6 programming is loaded from four different files:

- CPU/Host/Network Configuration File
- Line Card Configuration File
- Network Account Database File
- DNIS Account Database File OR Caller ID Database File (D6600 only)

These four files can be modified, uploaded, or downloaded separately.

 The version numbers used in the screens shown throughout this manual are for demonstration only. They might be different from the software version numbers you have.

 To confirm that the D6200 installation can locate your security key, install the key on a networked workstation that is running the Sentinel Protection Server software. For more information, refer to *Section 2.2 Installing Sentinel Protection Server* on page 6.

#### 3.1 Log On

A window appears prompting the user for the correct User ID and Password necessary to log on again.

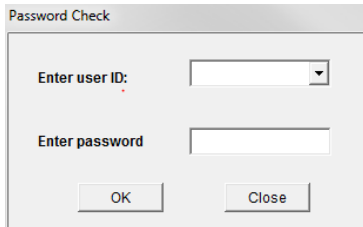

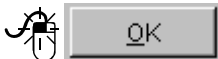

1. Enter 6200 (default User ID).
2. Press [TAB].
3. Enter 6200 (default User Password).

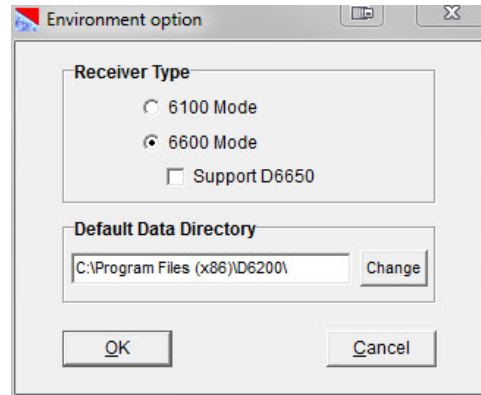
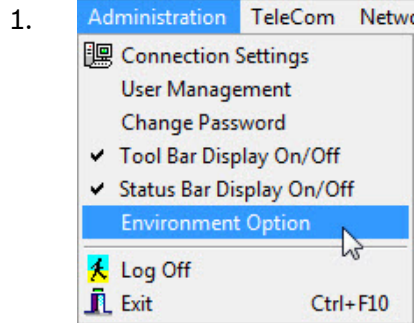

#### 3.2 Environment Option

With the D6200, you can choose between the D6600 mode and D6100 mode.



 The D6650 is an OEM line card for the D6600. If you do not have a D6650 line card installed in your D6600, do not select **Support D6650**.

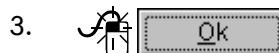
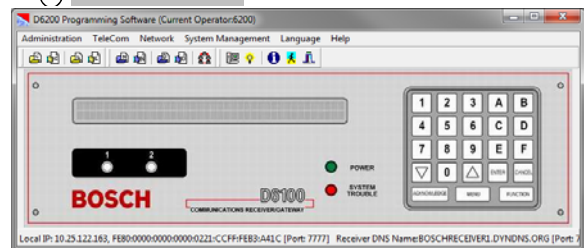
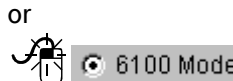
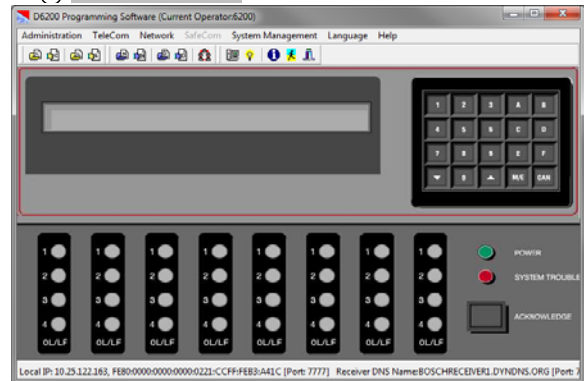

### 3.3 Connection Settings

The connection settings allow for the configuration of communication parameters for the D6200 to communicate with:

- D6600 or D6100IPv6/D6100i Receiver
- Network devices (D6686, D6682, D6680, DX4020, C900V2, C900TTL-E, or D9133TTL-E)

1. Administration Telecom Network

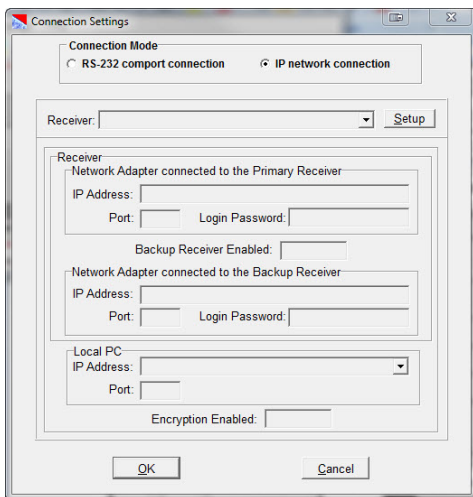
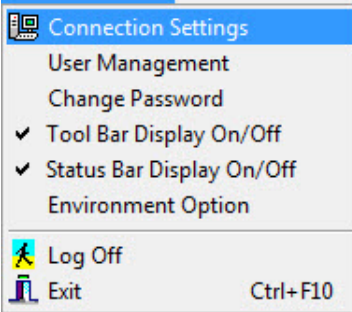

2. RS-232 comport connection

Refer to *Section 3.3.1 RS-232 Connection*, page 10.

or

IP network connection

Refer to *Section 3.3.2 Network Connection*, page 10.

#### 3.3.1 RS-232 Connection

Set Menu Item 6.1.5 to 0 (disabled) in the receiver to communicate using the COM4 for RS-232 direct connection.

**Table 1: RS-232 Settings**

COM port	COM1 to COM8
Data bits select	8 bits
Parity check select	None, Odd, or Even
Stop bits select	1 bit or 2 bit
Baud Rate Speed	38400

**Figure 4: D6200 RS-232 Connection Settings**

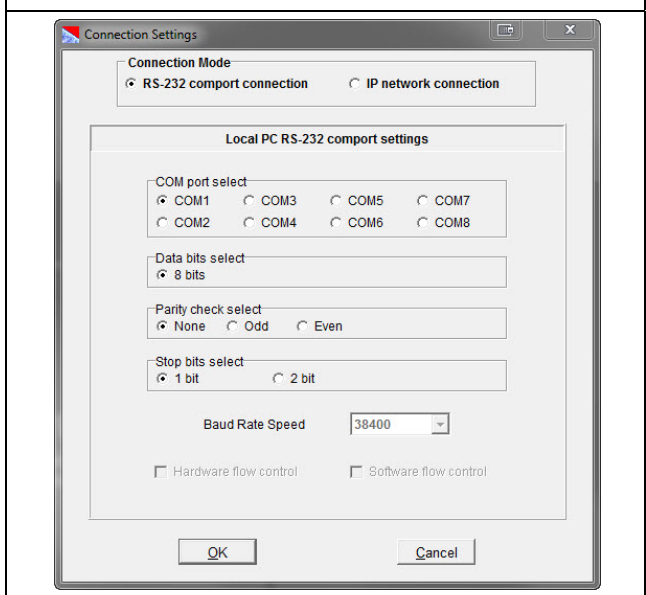

#### 3.3.2 Network Connection

Set Menu Item 6.1.5 in the receiver to 1 (enabled) to communicate using the TCP/IP network connection if the D6680 or D6682 is connected to COM4 or to 2 if the D6686 is used.

Set Menu Item 6.2.5 in the receiver to 1 to communicate using the TCP/IP network connection if the D6680 or D6682 is connected to COM1 or to 2 if the D6686 is used.

1. Administration Telecom Network

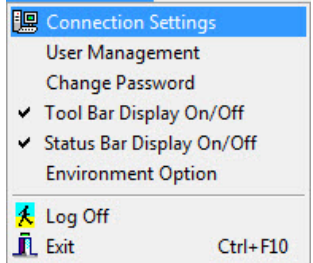

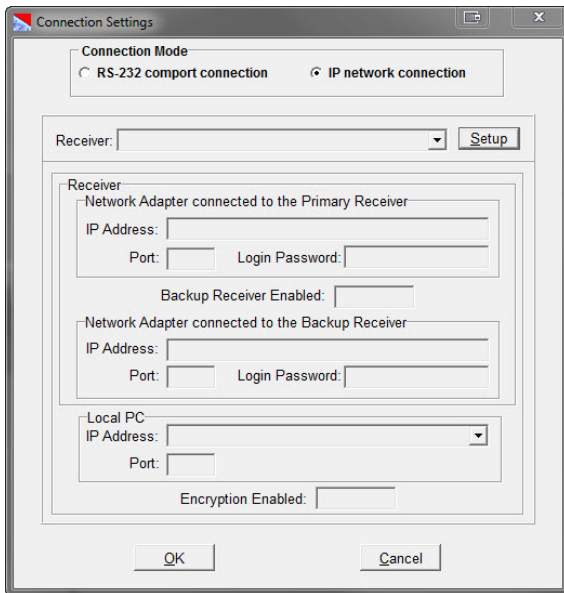

2.  IP network connection

3. Receiver: [ ] Setup

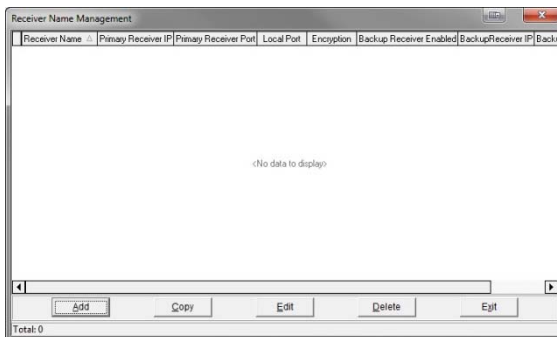

4. Add

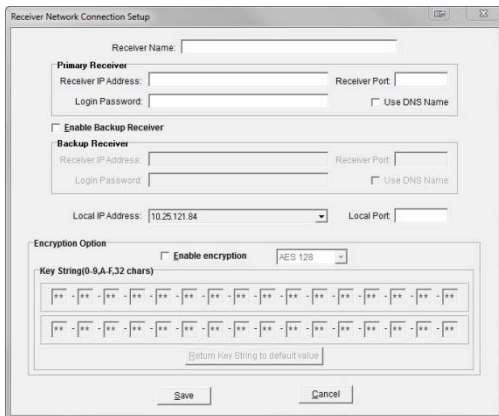

5. Give a name to the receiver.  
Receiver Name: [ ]

6. Enter the static IP Address or if using DNS select the **Use DNS Name** box and enter a valid Hostname for the primary receiver and port number of the receiver network adapter. If the receiver configuration has a Login Password to allow connection by D6200 workstations, enter that password here.



7. If a backup receiver is used,

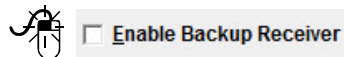

Enter the IP address and the port number of the backup receiver. If the receiver configuration has a Login Password to allow connection by D6200 workstations, enter that password here.



The local PC IP address cannot be changed (the software detects it each time it is started).

8. Set the Local Port to the desired port number.

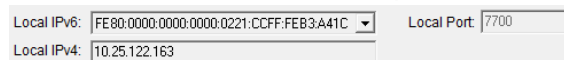

If **Enable Backup Receiver** is selected, this will default to the same port number of the primary receiver and cannot be changed.

9. To use encryption, check the box and select the proper encryption level (128, 192, or 256):



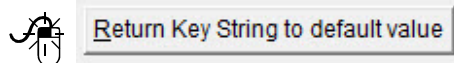
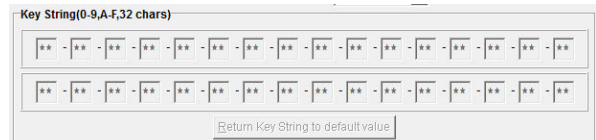

Enter the encryption key string in hex:

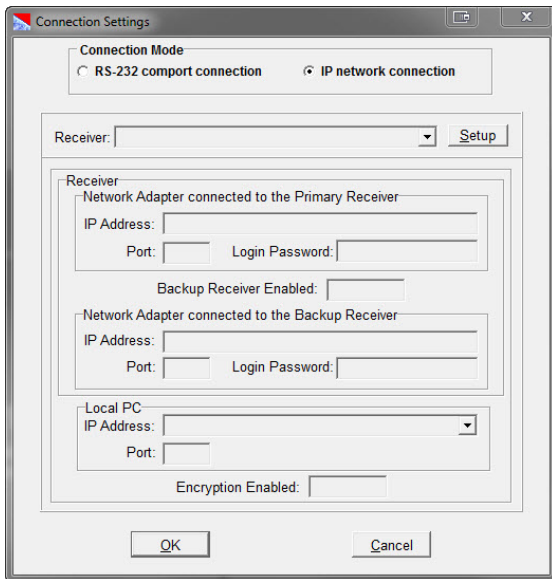

To return the encryption key string to the default value.

10.  



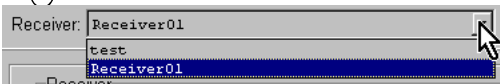

11.  

12.  

The D6200 software status bar changes (Figure 5 on page 12).

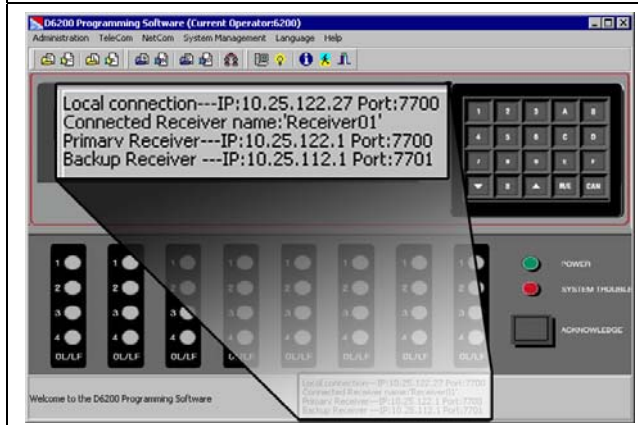
**Figure 5: D6200 Software Status Bar**



 If the PC running the D6200 software is DHCP to obtain an IP address, the server could change the IP address. If this happens, the D6200 software cannot communicate with the receiver until the receiver is programmed with the new assigned PC IP address. To avoid this problem, use a static IP address for the PC running the D6200 software or use a login password for the receiver.

 Make the encryption key string the same for all devices (D6686, D6682, D6680, D6600, D6100IPv6/D6100i, B426, B420, DX4020, C900V2, ITS-DX4020-G, D6202, D6200, D9133TTL-E, and C900TTL-E) or panel that supports encryption. Program the devices in the following order:

1. D6202 (Automation if used)
2. D6686/D6682/D6680 (D6600) or Ethernet port (D6100IPv6/D6100i)
3. D6600 or D6100IPv6/D6100i
4. B426, B420, DX4020, C900V2, ITS-DX4020-G, D9133TTL-E, and C900TTL-E
5. D6200 (last)

### 3.3.3 Password Protection

The D6200 Programming Software is password protected.

To log in, the user must enter the correct User ID and Password upon opening the D6200 software. Only one user can be logged on at a time.

To log off, select **Administration → Log Off**. A window opens prompting the user for the correct User ID and Password necessary to log on again.

 The default User ID is “6200.” The default Password is “6200.”

The D6200 passwords do not correspond with the D6600 passwords. This default user ID provides access to all security levels and features. Change the default User Password to something other than “6200.”

 Valid passwords have a maximum of eight alphanumeric characters (0 to 9, A to F). Use the D6200 software to customize the default passwords.

### 3.4 D6200 Icon Bar

Figure 6: D6200 Main Icons

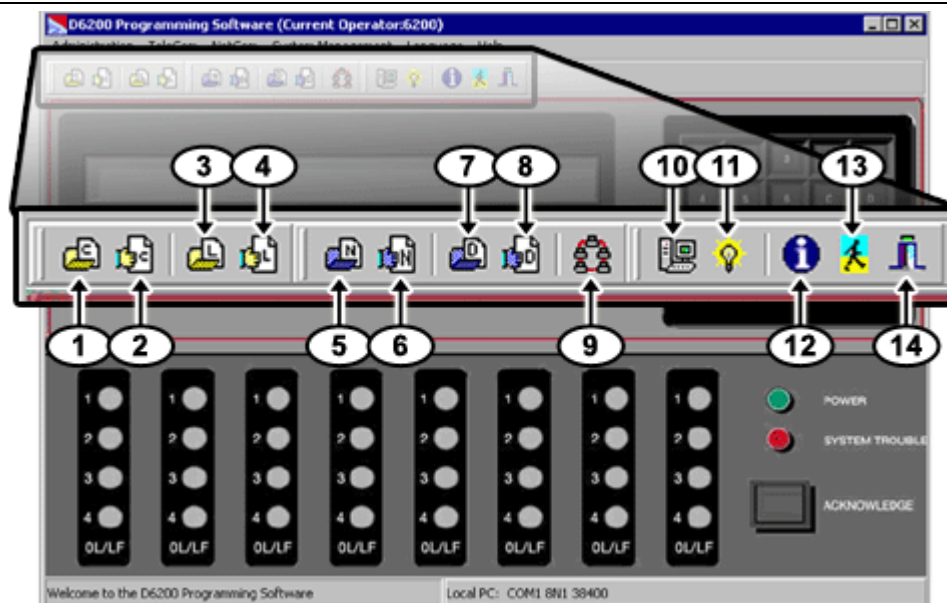

- |  |   |
|--|---|
| <p>1 - <b>Open/Manage CPU Configuration From File</b> – refer to Opening the Configuration File on page 16.</p> <p>2 - <b>Read/Manage CPU Configuration From Receiver</b> – refer to Reading the Configuration File on page 16.</p> <p>3 - <b>Open/Manage Line Configuration From File</b> – refer to Opening the Configuration File on page 16</p> <p>4 - <b>Read/Manage Line Configuration From Receiver</b> – refer to Reading the Configuration File on page 16</p> <p>5 - <b>Open/Manage Network Configuration From File</b> – refer to Opening the Configuration File on page 16</p> <p>6 - <b>Read/Manage Network Configuration From Receiver</b> – refer to Reading the Configuration File on page 16.</p> <p>7 - <b>Open/Manage Network Account Database Configuration From File</b> – refer to Opening the Database File on page 27.</p> | <p>8 - <b>Read/Manage Network Account Database Configuration From Receiver</b> – refer to Reading the Database from the Receiver on page 8.</p> <p>9 - <b>Show Account Status</b> – refer to Section 3.9.1 Show Account Status on page 43.</p> <p>10. <b>Connection Settings</b> – refer to Section 3.3 Connection Settings on page 10.</p> <p>11. <b>Software Upgrade Wizard</b> – refer to Section 4.1 Performing a One-Button Upgrade on page 51.</p> <p>12. <b>About</b> – Shows the Information dialog box for the D6200 software with the version number.</p> <p>13. <b>Log off</b> – Logs off the current user and brings up the User/Password Dialog (refer to Section 3.3.3 Password Protection on page 12).</p> <p>14. <b>Exit</b> – Exits from the D6200 Programming Software.</p> |
|--|---|

### 3.5 D6200 Administration

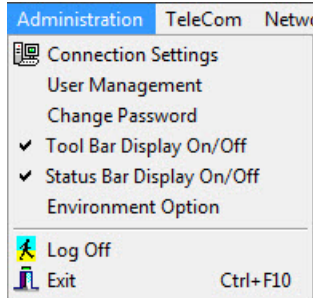

#### 3.5.1 User Management

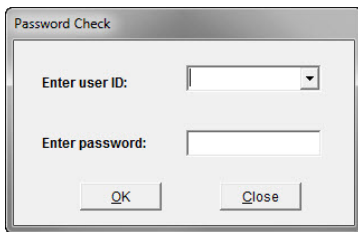
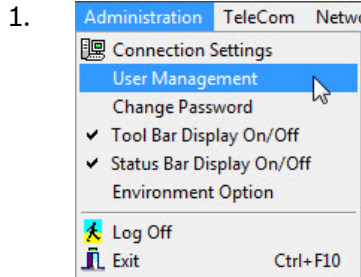

2. Enter User ID and password

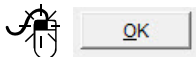

Master User (6200) access rights cannot be edited, and the master user account cannot be deleted. To change the master password, use the **Administration → Change Password** menu.

**Figure 7: Adding, Editing, or Deleting Users**

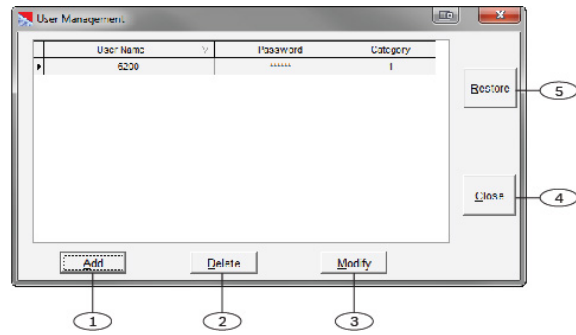

- 1 - **Add a user** - Click the Add button. Enter the user name, password, access rights, and then click the OK button.
- 2 - **Delete a user** - Click the appropriate cell, then click the Delete button.
- 3 - **Edit a user name, password or access rights** - Click the appropriate cell, and then click the Modify button. This allows the user to modify the current value. Make the appropriate changes, then click the OK button.
- 4 - Click the **Restore** button to restore the previously saved user configurations.
- 5 - Click the **Close** button and the changes are automatically saved.

#### Access Rights

Users of the D6200 Programming Software can be granted access rights to varying D6200 menu options. When adding or editing users from the User Management window, select access rights from one of the four categories shown in *Table 2* on page 14. If no access rights are designated, the user access rights default to Read/Off Line Modification (Category 3).

**Table 2: Access Rights to the D6200 Menu Options**

Category	Access Rights	Description
1	All	Users can access all the D6200 menu options.
2	All Except User Management	Users can access all the D6200 menu options except user management.
3	Read/Off Line Modification	Users can read configurations from the receiver and modify parameters but cannot program the receiver.
4	User Defined	Users can select or remove any of the menu options by double clicking on the menu title listed. A check mark indicates the user was granted access to the item. No check mark indicates the user was denied access to that option.

### Save and Restore User Management Files

Click the **C**lose button when the user configurations are established. This saves user configurations into a hidden file, which can be useful for updating all user configurations when performing D6200 upgrades.

After installing a new version of the D6200, click the **R**estore button. The previously saved user configurations are now loaded into the new D6200.

### 3.5.2 Changing User Password

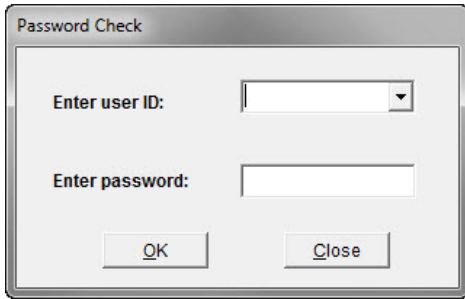
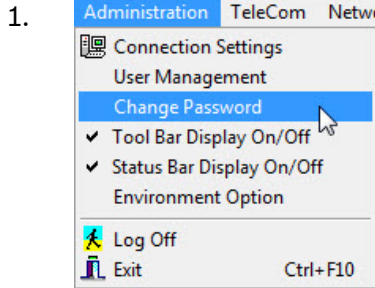

2. Enter valid user ID and password.

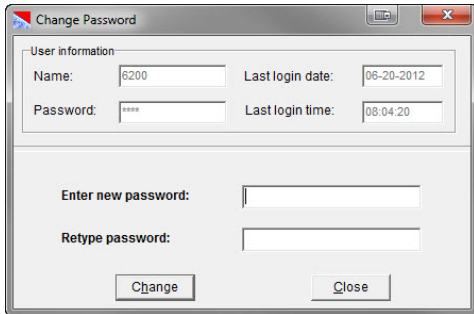

 If the name and password entered are inconsistent with the currently logged in user, an error message occurs and the operation is canceled.

4. Enter new password



5. Retype password



### 3.5.3 Environment Option

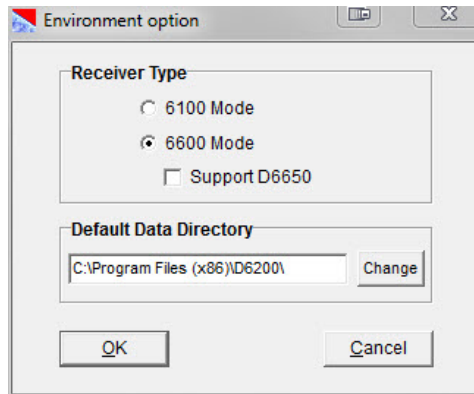
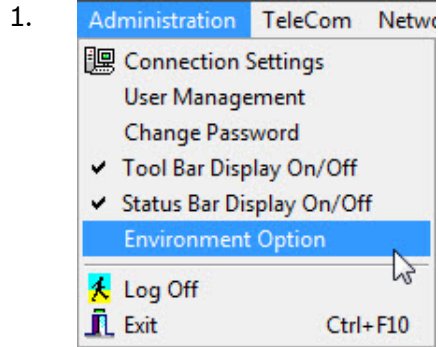

 The D6650 is an OEM line card for the D6600. If you do not have a D6650 line card installed in your D6600, do not select **Support D6650**.

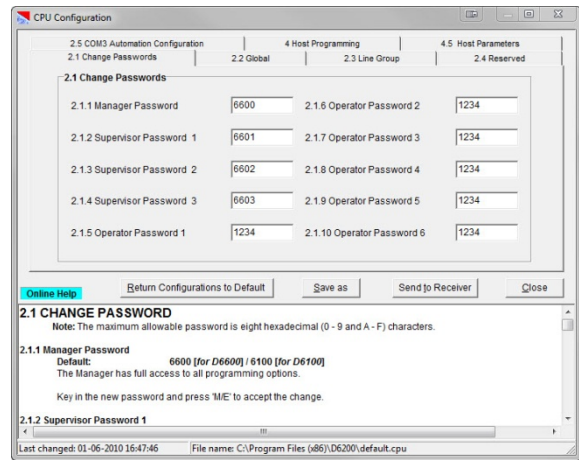
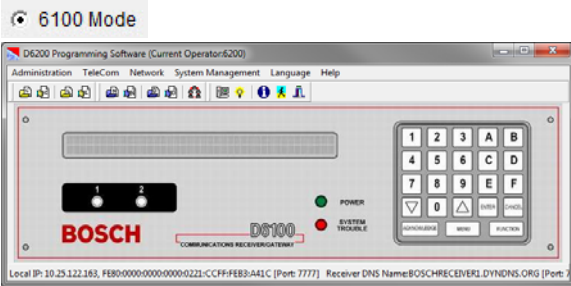
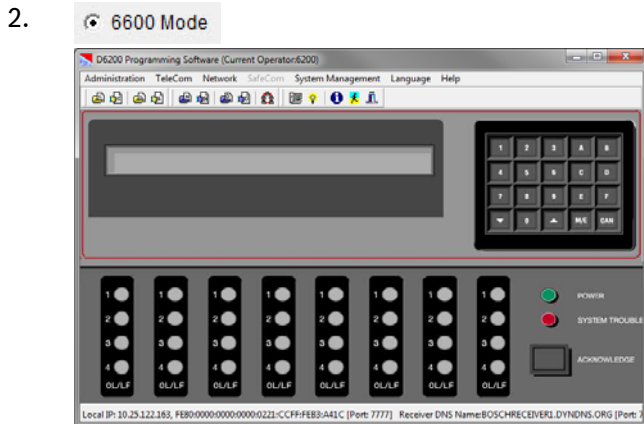

4. Change options.



### Reading the Configuration File

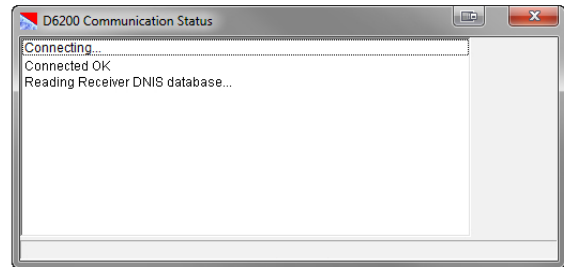
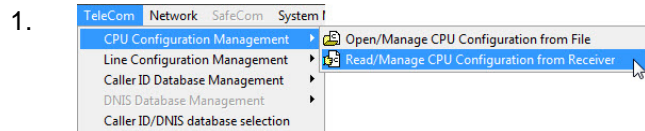

## 3.6 TeleCom Configuration

### 3.6.1 CPU Configuration

#### Opening the Configuration File

This option loads the CPU configuration file that is saved on the host PC.

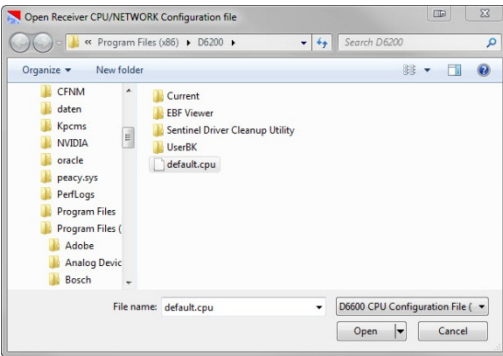
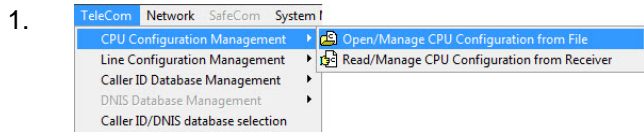

2. Select the configuration file.

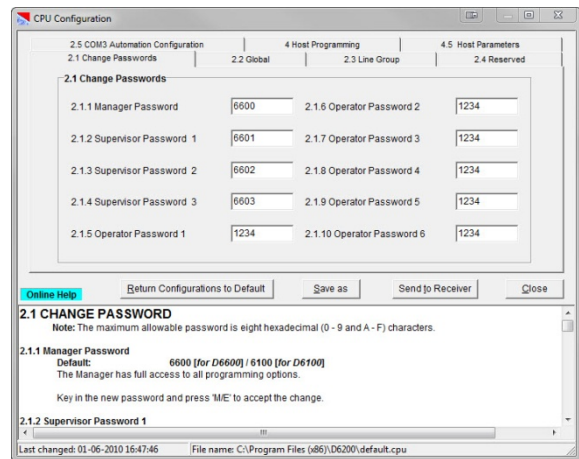

2. Change options.





### Editing the Configuration File

1. Change options.

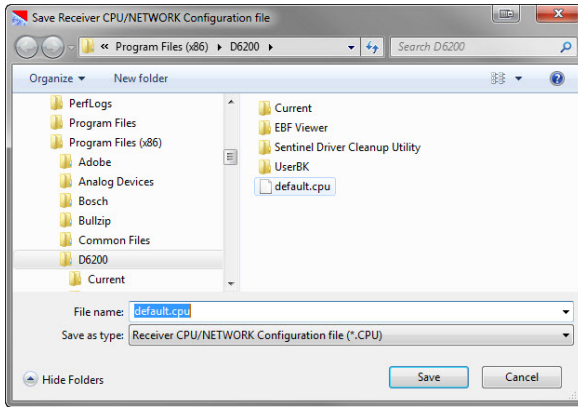

3. Enter a filename.



### Sending the Configuration File

After modifying the configuration file, send it back to the receiver for the changes to take effect.

Changed parameters take effect immediately at the receiver. For example, after making modifications to the line formats, update the line card.

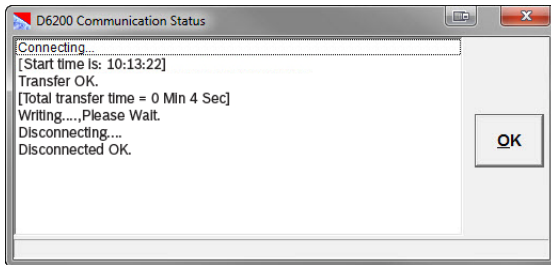
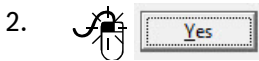
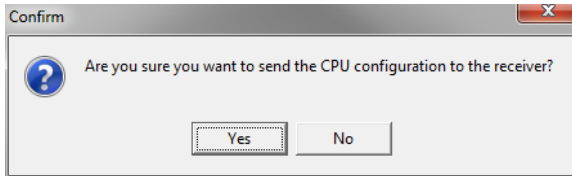
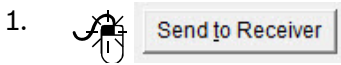

The parameter file is in the receiver.

### 3.6.2 Line Card Configuration

#### Opening the Configuration File

This option loads the CPU configuration file saved on the Host PC.

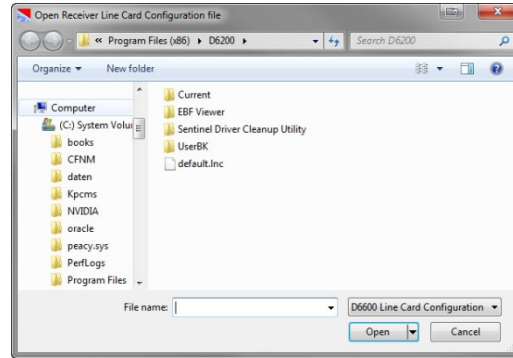
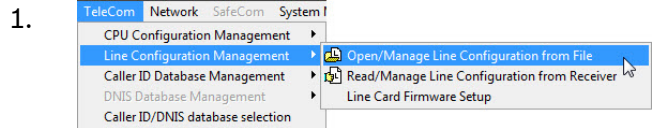

2. Select the desired configuration file.

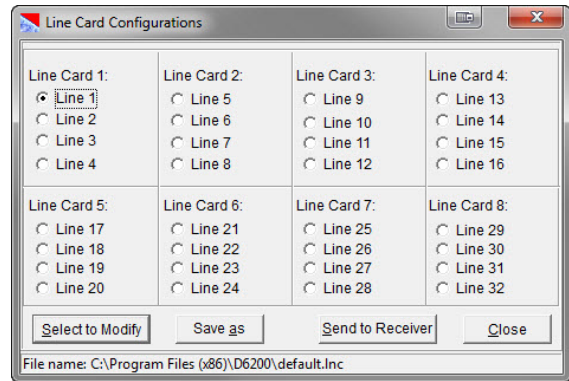

4. Select a line.



Refer to *Editing the Configuration File* on page 18.

### Reading the Configuration File

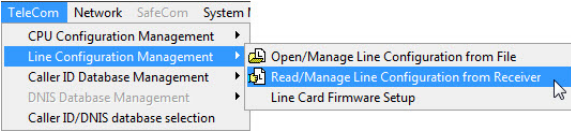
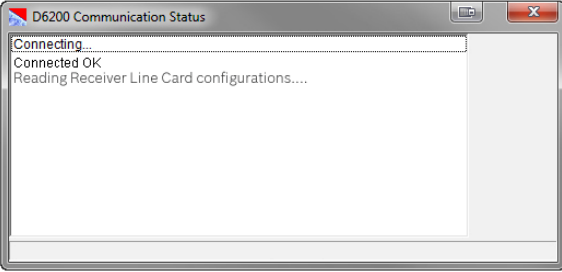
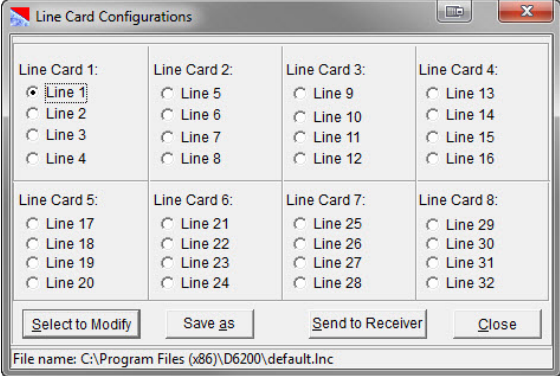
- 
  

  

2. Select a line.

- 

Refer to *Editing the Configuration File*, below.

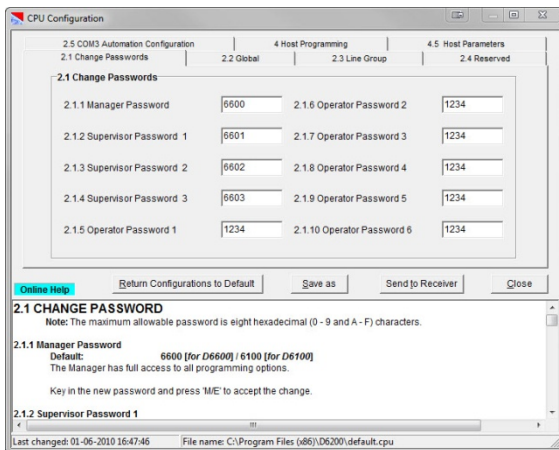
### Editing the Configuration File





1. Changed options.

- 

### Sending the Configuration File

After modifying the configuration file, send it back to the receiver for the changes to take effect.

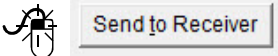
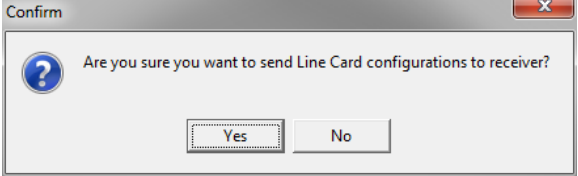
Changed parameters take effect immediately at the receiver. For example, after making modifications to the line formats, update the line card.

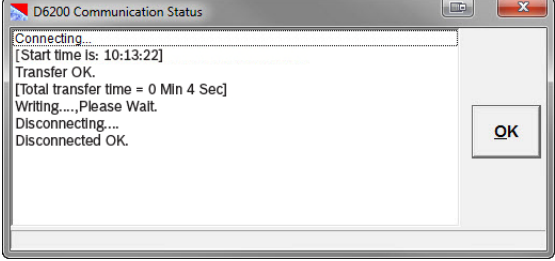
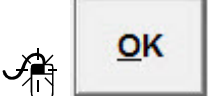
- 
  

- 
  

- 

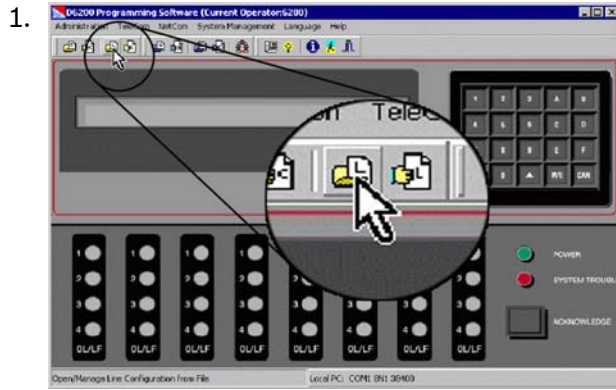
The parameter file is in the receiver.

### 3.6.3 Default Line Configuration from D6200 Software

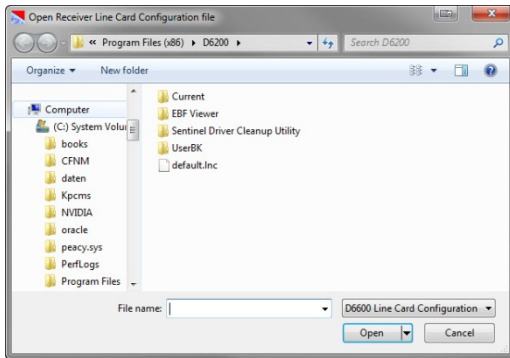
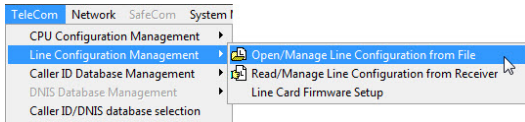

OR



2. Select a file.



**D6600:**

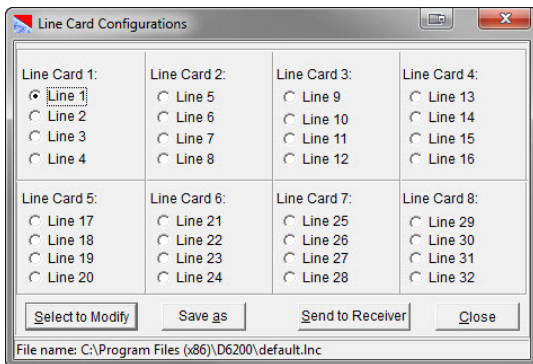

**D6100:**

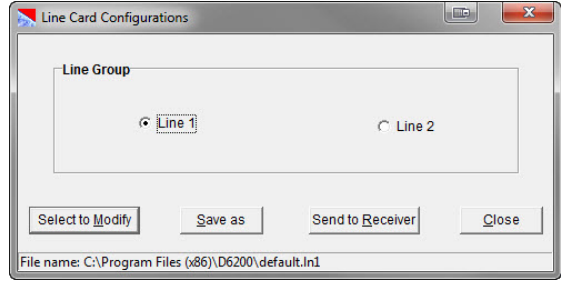

4. Select a line card to modify.

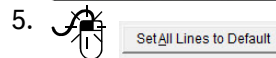
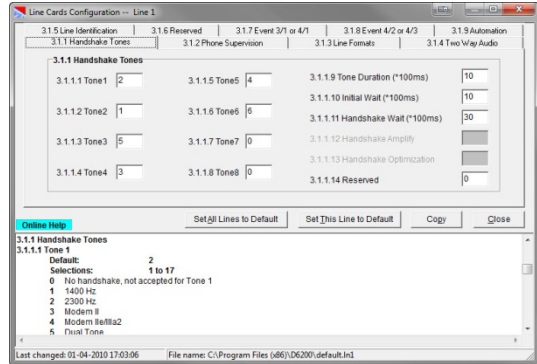
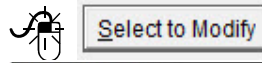

Resets all lines in all installed line cards to the default.

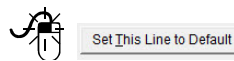

Resets only the modified line to the default.



after all modifications to all lines are made.



No handshake tone is sent if the digital signal processor (DSP) does not support that particular format. Confirm that the line card configuration supports the desired format before assigning it.

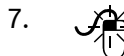

if no other line cards must be modified.

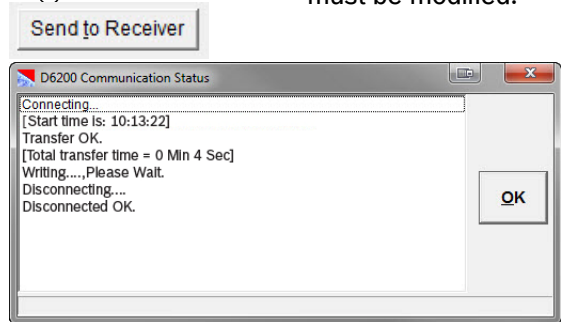

### 3.6.4 Copying Selected Line Configuration from D6200 Software

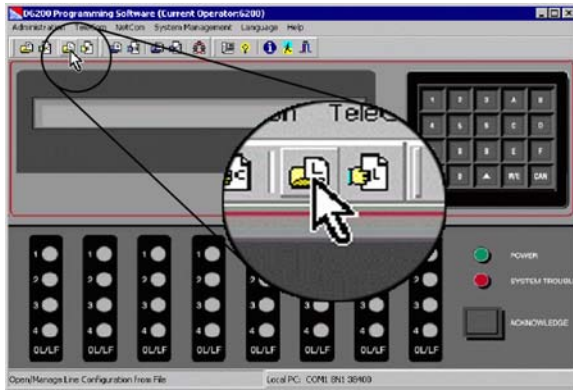

OR

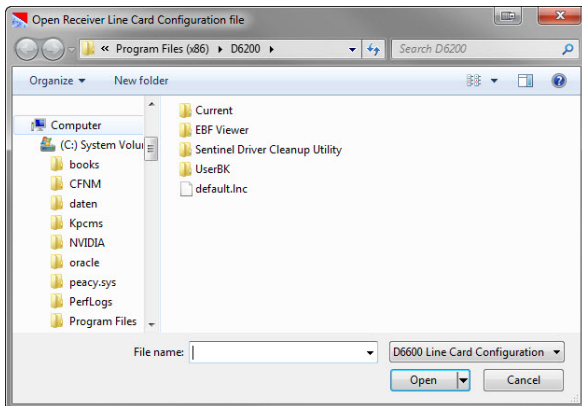
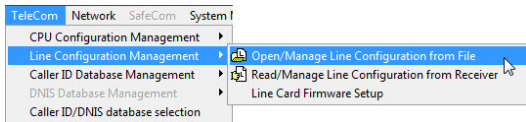

Select a file.

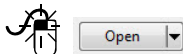

### D6600:

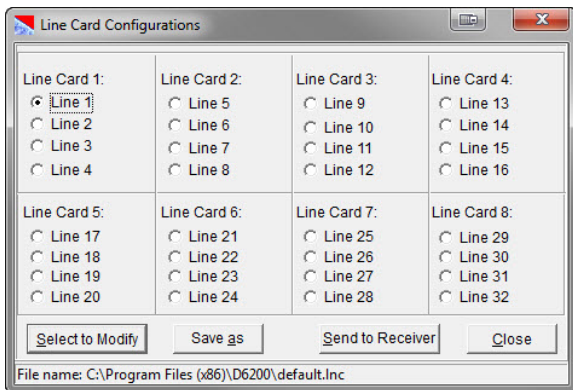

### D6100:

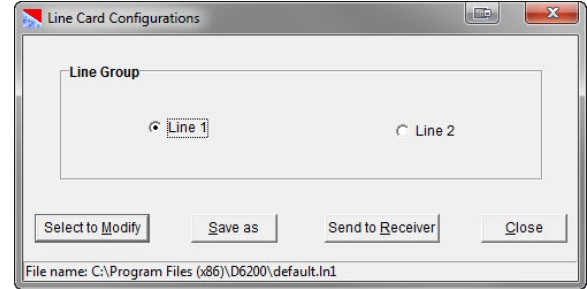

Select a file.

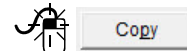
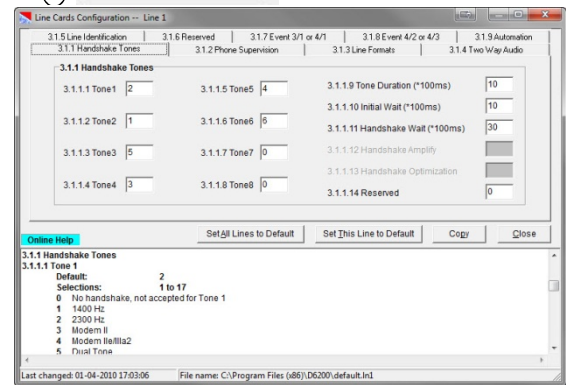

### D6600:

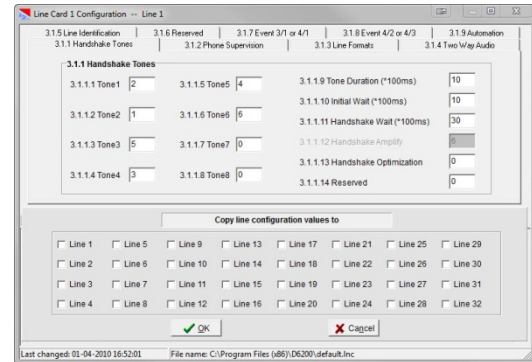

### D6100:

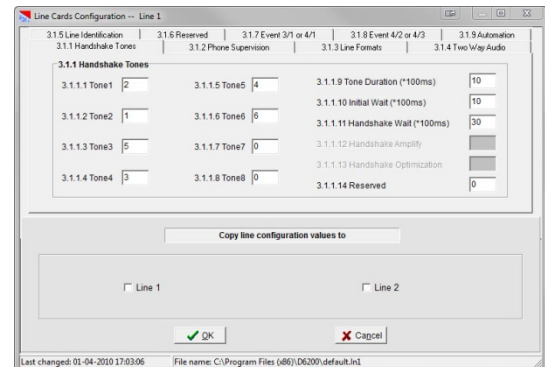

each of the boxes to which you are copying the line configuration.





if no other line cards need to be modified.

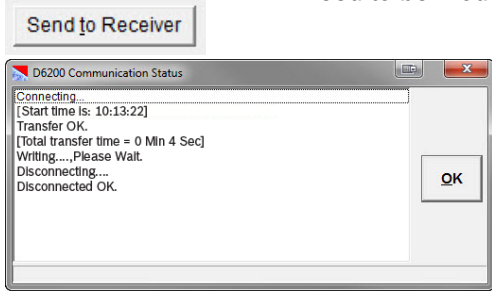

### 3.7 Network Configuration

#### 3.7.1 Opening the Configuration File

This option loads the CPU configuration file saved on the host PC.

- 1.

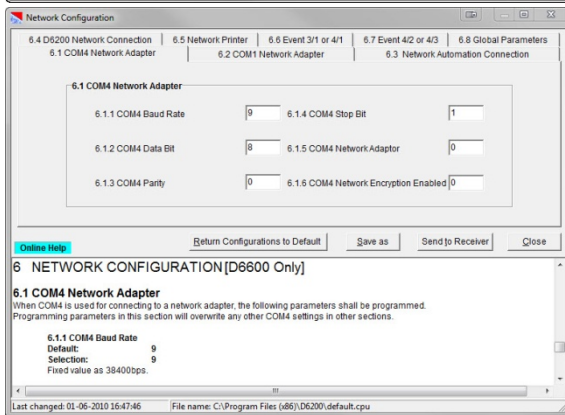
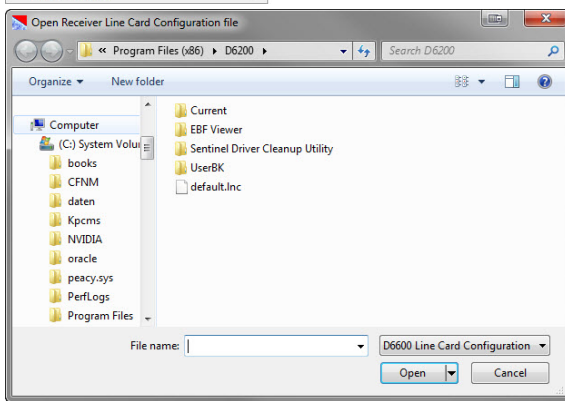

2. Refer to *Section 3.7.3* Editing the Configuration File

#### 3.7.2 Reading the Configuration File

- 1.

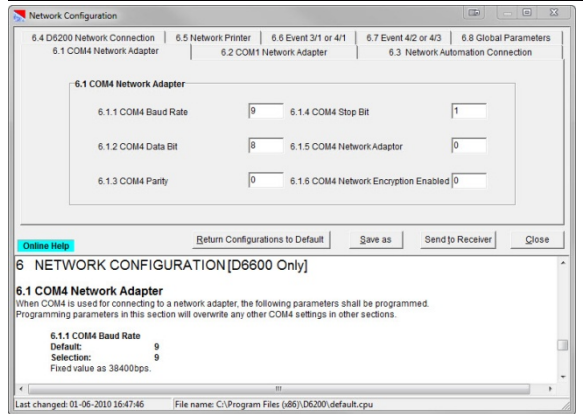
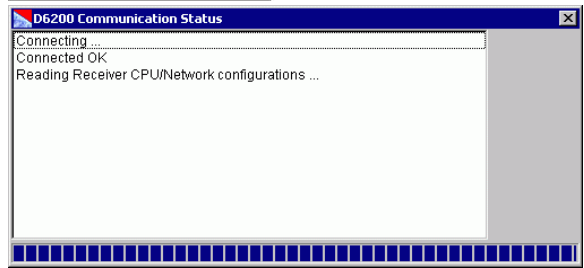

2. Refer to *Section 3.7.3* Editing the Configuration File.

#### 3.7.3 Editing the Configuration File

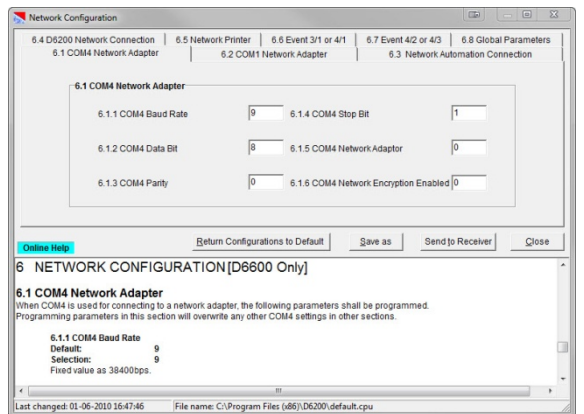





1. Change options.

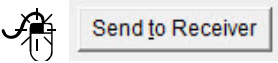
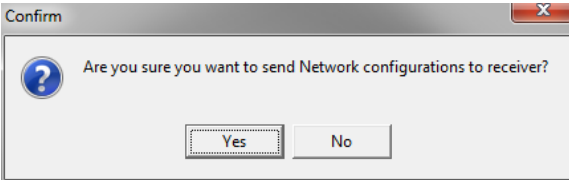

### 3.7.4 Sending the Configuration File

After modifying the configuration file, send it back to the receiver for the changes to take effect

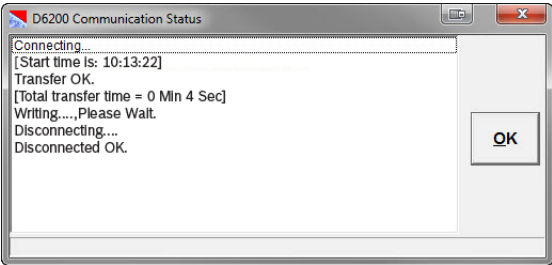
Changed parameters take effect immediately at the receiver. For example, after making modifications to the line formats, update the line card.

1.  
2.  
3. 

The parameter file is in the receiver.

Handshake Optimization uses the caller ID information provided by the public switched telephone network (PSTN) to create a database of a maximum of 16000 dialers. The receiver uses this Caller ID information to output the required handshake for that particular dialer. If the dialer does not respond to the optimized handshake, the receiver outputs the handshakes programmed for that line. For more information on the Caller ID Database, refer to the *D6600/D6100IPv6 Program Entry Guide* (P/N: 4998122702).

 The D6600 can store only a DNIS Database or a Caller ID Database at one time. The databases cannot be stored simultaneously.

### Enabling Caller ID Database

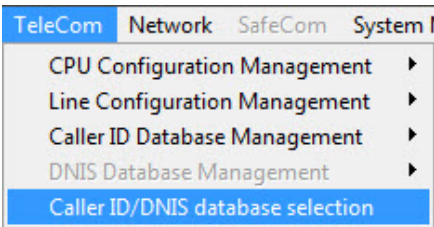
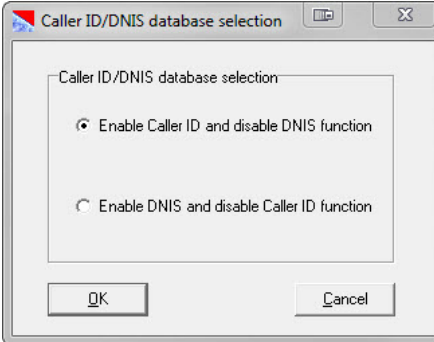
1. 
2. 



## 3.8 Databases

### 3.8.1 Caller ID (D6600 Only)

You can access the Caller ID Database only through the D6200 software, which logs all phone numbers coming into the receiver and associates each number with a handshake.

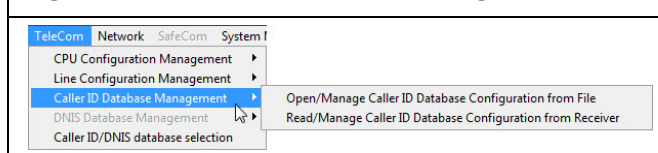
**Figure 8: Caller ID Database Management Menu**

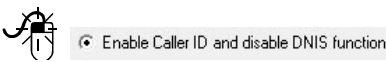

2. 
3. 

The database is:

- automatically created by the receiver, or
- manually created by the user

The database is created with the first 16000 phone numbers entered or received.

### Opening the Database

1.

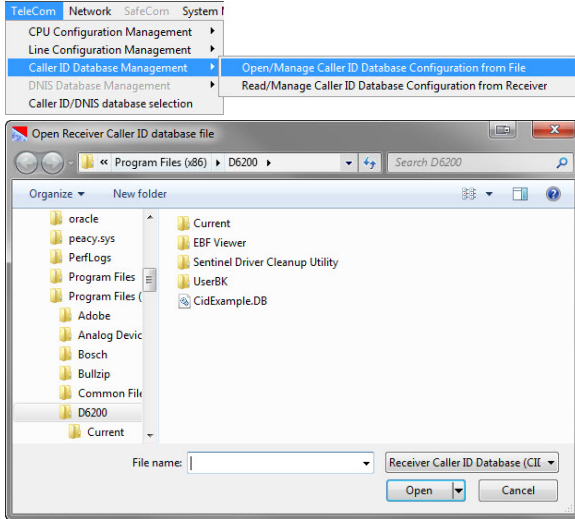

2.

to select the desired database.

3.

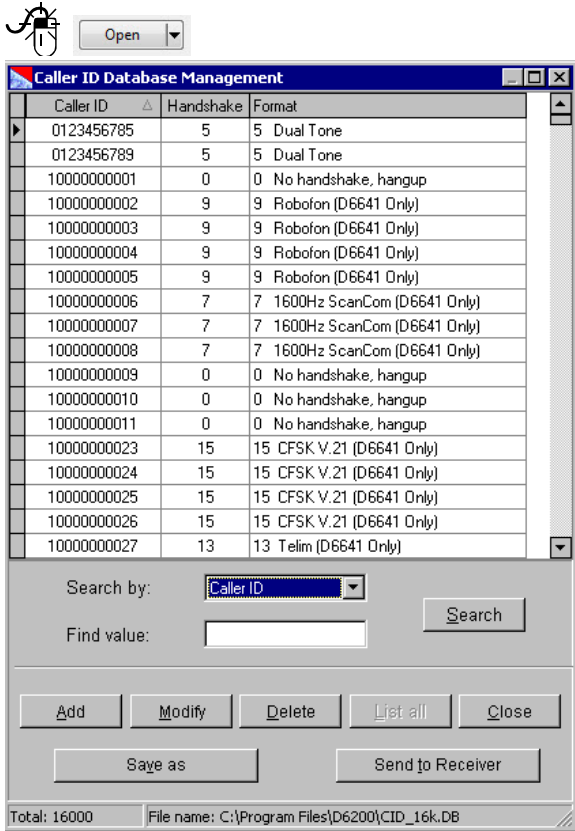

4.

**Add** Adds a new number.

**Modify** Modifies an existing number.

**Delete** Deletes an existing number.

Saves the database with a new name (refer to *Saving the Database with a New Name* on page 26).

Sends the database to the receiver (refer to *Sending the Database* on page 26).

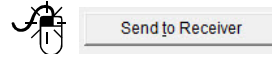
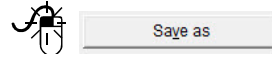

### Reading the Database from the Receiver

1.

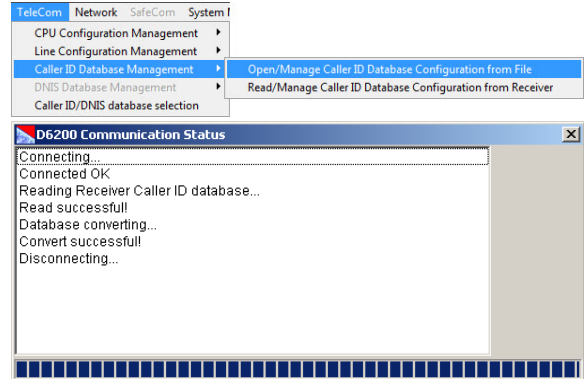

2.

**Add** Adds a new number.

**Modify** Modifies an existing number.

**Delete** Deletes an existing number.

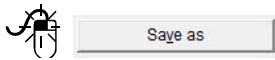

Saves the database with a new name (refer to *Saving the Database with a New Name* on page 26).

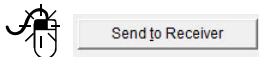

Sends the database to the receiver (refer to *Sending the Database* on page 26).

### Saving the Database with a New Name

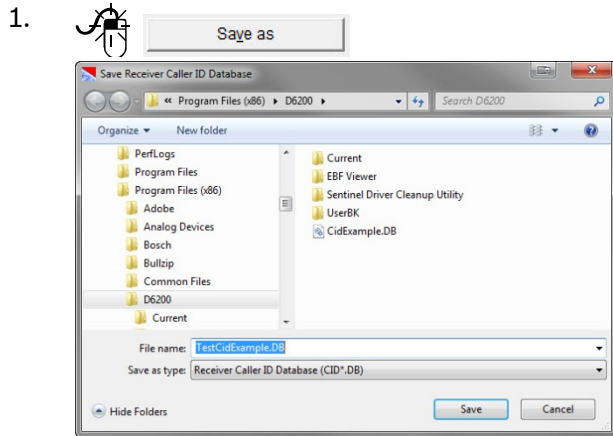

2. Enter new filename.

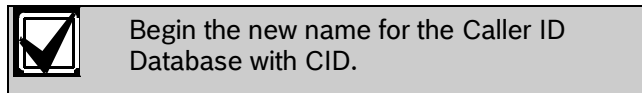

### Sending the Database

After modifying the configuration file, send it back to the receiver for the changes to take effect. Changed parameters take effect immediately at the receiver.

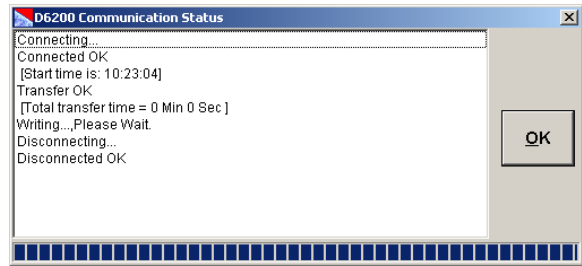
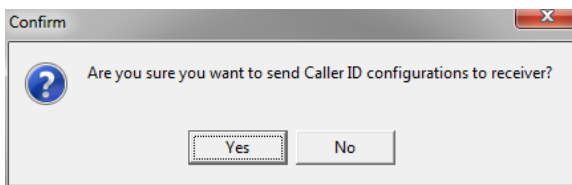
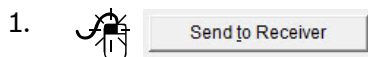

The database is in the receiver.

### 3.8.2 DNIS (D6600 Only)

The Dialed Number Identification Service (DNIS) Database identifies the proper handshake and communication format based on the DNIS account number received and can be accessed only through the D6200 software.

**Figure 9: DNIS Database Menu Commands**

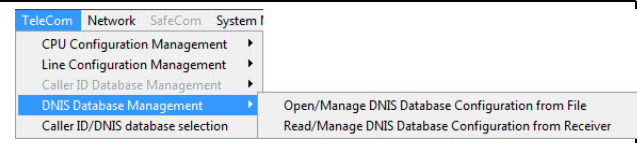

The maximum capacity is 2000 DNIS accounts. All accounts must be manually entered using the D6200 software.

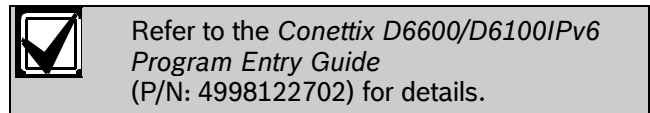



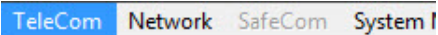

### Enabling DNIS Database

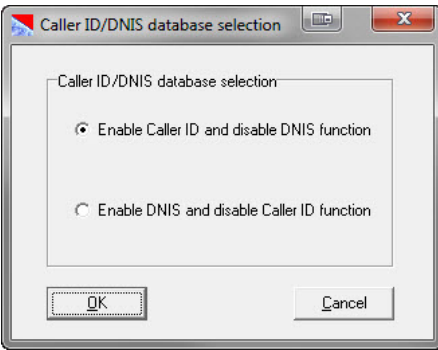
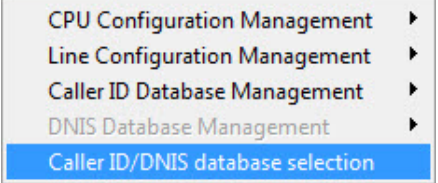
1. 





2.   Enable DNIS and disable Caller ID function

3. 

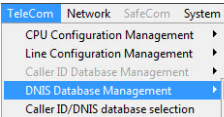
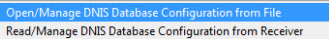
### Opening the Database

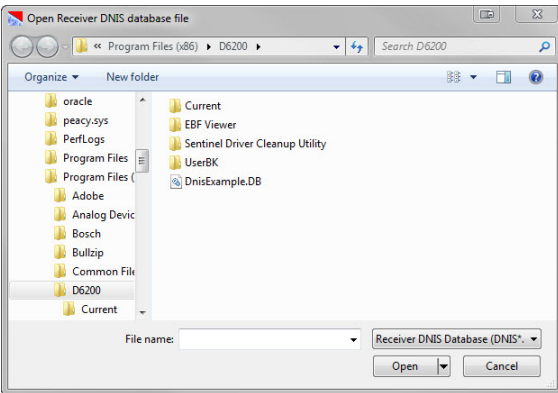
1.  



2.  to select the desired database.

3. 

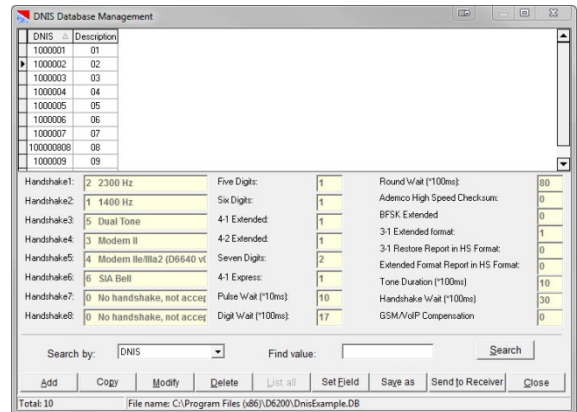

4. 

Adds a new DNIS account.



Modifies an existing DNIS account.



Deletes an existing DNIS account.









Saves the database with a new name (refer to *Saving the Database with a New Name* on page 26).

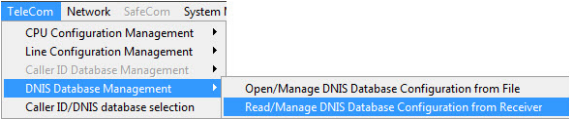
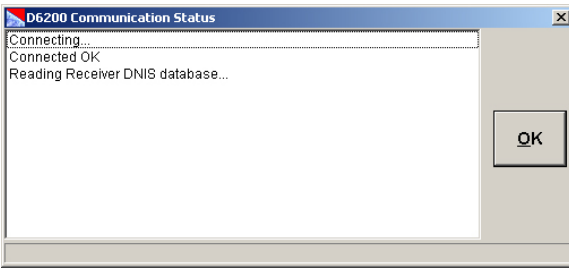
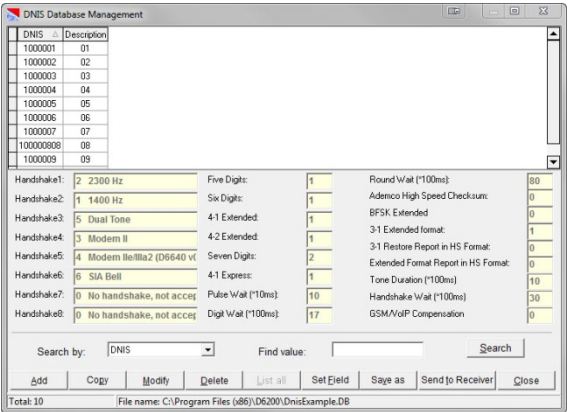

Sends the database to the receiver (refer to *Sending the Database* on page 26).

### Reading the Database from the Receiver

- 

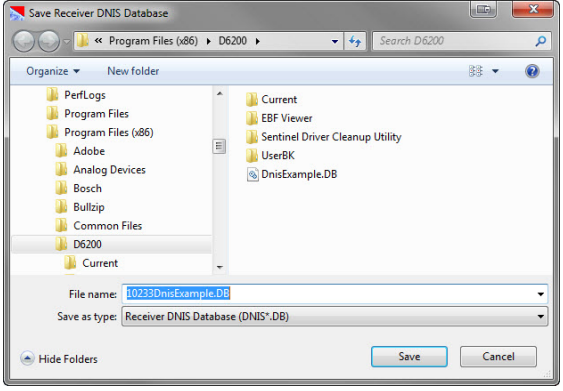

-  **Add**  
Adds a new DNIS account.
  -  **Modify**  
Modifies an existing DNIS account.
  -  **Delete**  
Deletes an existing DNIS account.
  -  **Save as**  
Saves the database with a new name (refer to *Saving the Database with a New Name* on page 26).
  -  **Send to Receiver**  
Sends the database to the receiver (refer to *Sending the Database* on page 26).

### Saving the Database with a New Name





-  **Save as**

- Enter a new name.

 **Begin the new name for the DNIS Database file with DNIS.**

-  **Save**

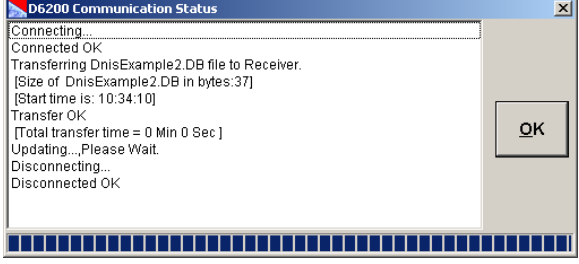
### Sending the Database

After modifying the configuration file, send it back to the receiver for the changes to take effect. Changed parameters take effect immediately at the receiver.

-  **Send to Receiver**

-  **Yes**

-  **OK**

The database is in the receiver.

### 3.8.3 Network Accounts

You must program each network account before the D6600/D6100IPv6 can supervise Bosch control panels connected to the network or C900V2/C900.



Starting with v2.00, account databases are **all** NNC (Network Naming Convention). Network Account databases entered as static IP addresses is no longer supported.

The Account Database File stores the programming for the field accounts. The D6600/D6100IPv6 processes signals, and manages and supervises field accounts using the information in this file.



If the D6600/D6100IPv6 is rebooted, all account database configurations are lost. Use the D6200 to save all database configuration changes to the "ACTXX.DB" file (where xx = filename string). After rebooting the D6600/D6100IPv6, reload the database to the receiver.

The D6600/D6100IPv6 receiver and the D6200 software maintain the network account databases in either NNC mode or Static IP mode.

### Opening the Database File

1. Determine the type of network that is hosted.
- 2.

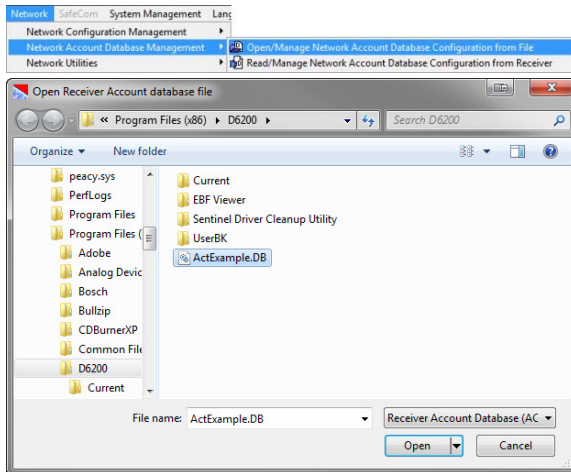

3. Select the desired database.
- 4.

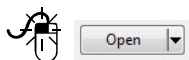

### Reading the Database from the Receiver

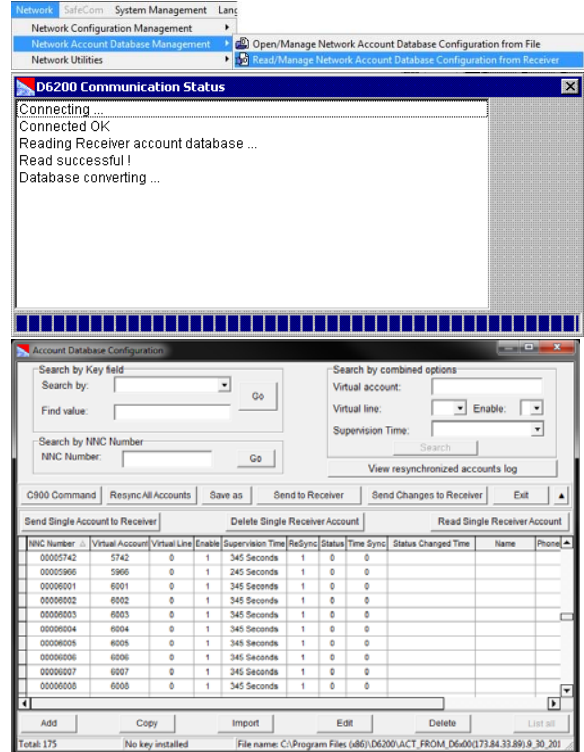

### Editing the Database File

Figure 10 illustrates all the options available in the account.



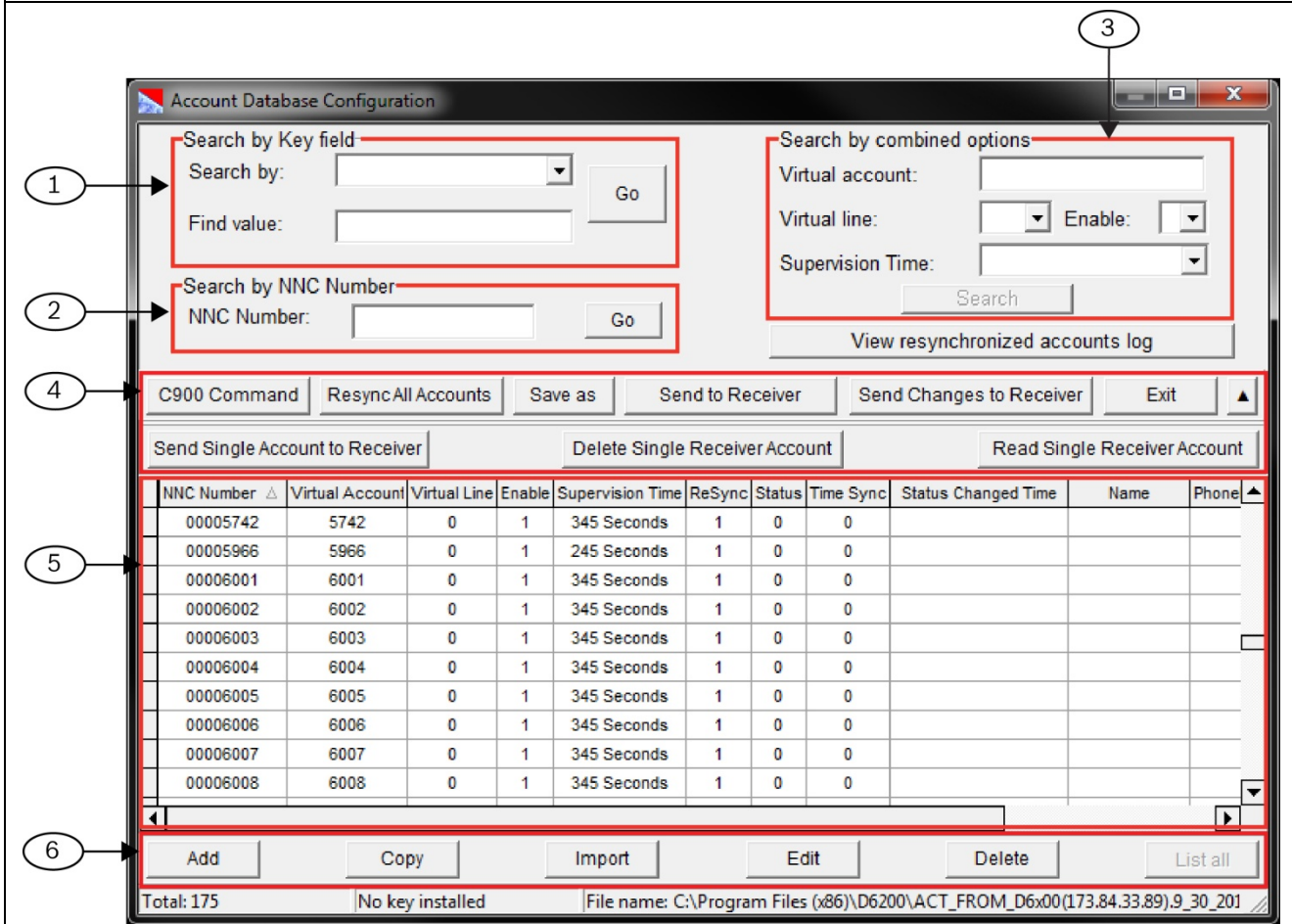
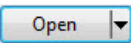

**Figure 10: Network Account Database Configuration**



- 1 - **Search by Key field** - Allows account searching by key field (refer to Search by Key Field on page 37).
- 2 - **Search by NNC number** - Allows account searching by NNC number (refer to Section 3.8.5 Searching for Account on page 37).
- 3 - **Search by combined options** - Allows account searching by Virtual Account Number, Virtual Line, Panel Poll Rate, or Communication Enabled/Disabled (refer to Search by Combined Options on page 37).
- 4 - **Database file options** - These options affect the database file as a whole.
  - C900 Command – refer to Section 3.8.6 C900 Commands on page 38.
  - Resync All Accounts – Set all accounts to resync with the receiver
  - Save as - refer to Saving the Database with a New Name on page 34.
  - Send to Receiver - refer to Sending the Database on page 35.

- Send Changes to Receiver - refer to Sending the Database on page 35.
  - Exit – Exit the account database file
  - Send Single Account to Receiver –
  - Delete Single Receiver Account -
  - Read Single Receiver Account -
  - 5 - **Account listing** - A listing of all accounts in the currently open database
  - 6 - **Account options** - These options affect the individual accounts in the database.
    - Add - refer to Add or Edit Account on page 29
    - Copy - refer to Copy an Account on page 33
- Import - refer to**
- Import an Account on page 33
  - Edit - refer to Add or Edit Account on page 29
  - Delete - refer to Delete an Account on page 34

**Add or Edit Account**

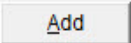
1.  highlight an account.
2.   open an existing account  
or  
  add a new account

 Each account must have a unique NNC Number - duplicates are not allowed. If an account with an existing name is entered (when attempting to Add), the D6200 shows an error message indicating that the NNC Number already exists.

3. Configure or edit account as necessary.

 The NNC number of a Bosch control panel is the least significant 8-digits if it is more than 8. For example, Account # 1234567890 would be NNC # 34567890.

 On a single network, operate all field devices with static IP addresses **or** NNC numbers. IP address identification **and** Area 1 account or serial number identification cannot exist in the same database.  
Network interface modules (NIMs) with static IP addresses can be identified by the Area 1 Account Number or Serial Number, allowing an NNC database to supervise them.

 All required fields are marked as shown.

4. Each account listing has three settings tabs.  
Select the tab at the top of each screen to view or modify.

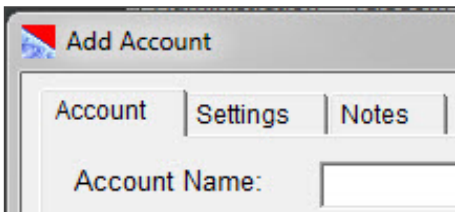

**Account Tab**

**Figure 11: Account Tab**

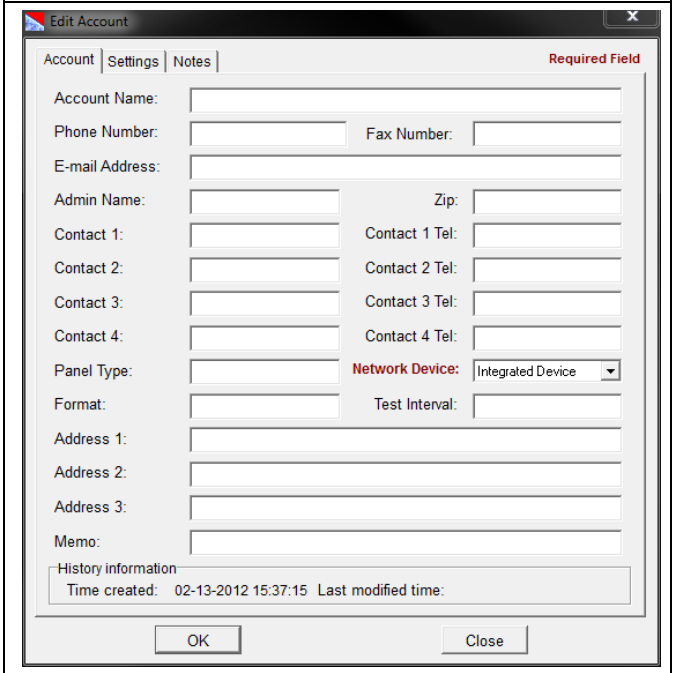

All information on the Account tab is for reference only except for the Network Device which is required to be selected. Select the appropriate Net Device type in the Net Device field.

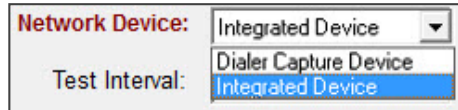

For Bosch control panels that use on IP or a network interface module, select **Integrated Device**. If a C900V2/C900TTL-E is used, select **Dialer Capture Device**.

Settings Tab

Figure 12: Settings Tab

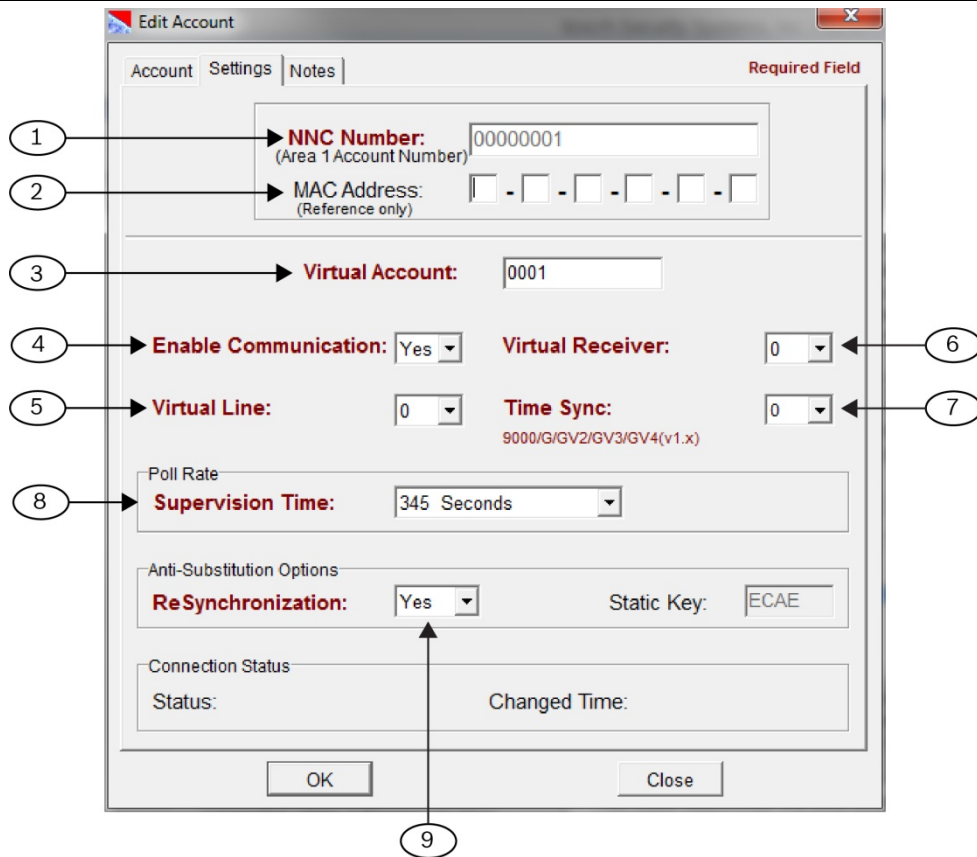

- |   |   |
|---|---|
| <ul style="list-style-type: none"> <li>1 - <b>NNC Number</b> – Area 1 account number of Bosch Control Panel or C900V2 Serial Number</li> <li>2 - <b>MAC Address</b> – MAC Address of the network module</li> <li>3 - <b>Virtual Account</b> – Virtual Account number</li> <li>4 - <b>Enable Communication</b> – Enable account for network communications</li> <li>5 - <b>Virtual Line</b> – Virtual line number for network account reporting</li> </ul> | <ul style="list-style-type: none"> <li>6 - <b>Virtual Receiver</b> – Virtual receiver number for network account reporting</li> <li>7 - <b>Time Sync</b> – Enable Time Sync for network account</li> <li>8 - <b>Supervision Time</b> – Supervision time of network account</li> <li>9 - <b>Resynchronization (Anti-Substitution)</b> – Network account set to resync with receiver</li> </ul> |
|---|---|

**NNC Number** (Item 1 in Figure 12 on page 30)

Enter either the account number of Area 1 from the Bosch Control Panel or the Serial number of the C900V2/C900TTL-E

**NNC Number:**   
(Area 1 Account Number)

**MAC Address** (Item 2 in Figure 12 on page 30)



The MAC address is for reference only and is not required for an account to report.

This six-byte (twelve-digit) address is hard-coded into the network device or control panel and identifies the device on the network. Refer to the control panel or NIM's installation guide for information on finding the MAC address.

**Virtual Account** (Item 3 in Figure 12 on page 30)

Enter the account number of the control panel as it is to be identified in the automation system.

**Virtual Account :**



A Virtual Account number identifies the control panel that lost its network connection when a "Communication Failure" message appears. If the Virtual Account Replacement function is disabled [refer to *Menu Item 6.8.4 Virtual Account Replacement* in the *D6600/D6100IPv6 Program Entry Guide* (P/N: 4998122702)], the default message "ACT0000 Communication Failure" appears. If this happens, load the network database from the D6600 into the D6200 and view the individual account states to identify which control panel has lost its network connection.

**Enable Communication** (Item 4 in Figure 12 on page 30)

Enables or disables communication between the networked control panel and D6600/D6100IPv6.

**Enable Communication :**

**Virtual Line** (Item 5 in Figure 12 on page 30)

Enter the line number (0 to 34) to identify the control panel and account if the automation system is used in combination with the account number for the alarm control panel. If the line number is not used, enter zero.

**Virtual Line:**

**Virtual Receiver** (Item 6 in Figure 12 on page 30)

Because the D6600/D6100IPv6 handles multiple PSTN lines, each account can be individually programmed to have a different receiver number.

**Virtual Receiver:**

<b>Default:</b>	<b>0</b>
<b>Selection:</b>	<b>0, 01 to 99</b>
0	The receiver uses the receiver number programmed in <i>Menu Item 2.2.30</i> in the D6600.
01 to 99	The receiver uses this number for sending information from the network account to the automation software.

**Time Sync** (Item 7 in Figure 12 on page 30)

If set to 1 and the account is a Bosch 9000/G/GV2/GV3/GV4(v1.x) control panel, the receiver synchronizes the control panel's time with the receiver's time by setting the minutes of the panel. If set to 0, the times are not synchronized.

**Time Sync:**



This only occurs between 10 and 50 minutes after the hour and does not occur between 50 and 10 minutes at the top of the hour. This time sync does not set the date or the hour of the panel.

**Supervision Time** (Item 8 in Figure 12 on page 30)

This value determines the time before the receiver declares a Communications Failure if no message is received from the control panel or dialer capture device. Set the desired Supervision Time for the account.

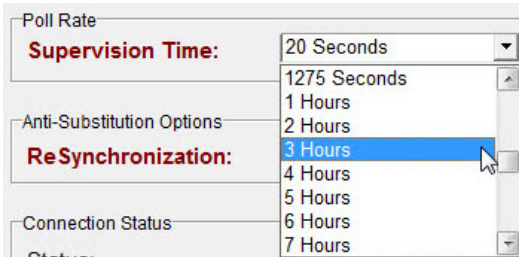

The receiver supports a supervision time from 0 to 1275 seconds and from 1 to 255 hours. The Bosch control panel sends a range of polls (0 to 65535 sec). The C900V2 / C900TTL-E poll rate ranges from:

- 0 to 255 sec, using the C900 control commands from the D6200 software
- 75 or 240 sec, depending on the DIP switch position on the C900TTL-E or C900V2

Any C900 control command sent to the receiver (and to the selected C900 device) from the D6200 software supersedes any DIP switch settings. The DIP switch settings take affect when the C900TTL-E or C900V2 reboots.

C900 v1.10 or greater has a 75 sec default poll rate and C900 v1.09 or less has a 30 sec default poll rate when DIP Switch 7 is in the OFF position.

See the control panel, network module, or dialer capture device literature for recommended or required supervision time.

**Anti-Substitution (Resynchronization)** (Item 9 in Figure 12 on page 30)

Set Resynchronization to YES when entering new accounts and when a system is being replaced.

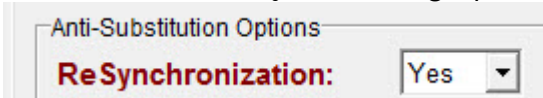

Default:	Yes
Selection:	Yes or No
Yes	Receiver issues a new static key* to this account the next time it communicates with the control panel.
No	Receiver does not issue a new static key*; the control panel uses the key it received from the first communication with the receiver. If this key is incorrect, the communication will generate a substitution alarm.
* The receiver issues static keys to all new accounts. If the panel side supports this 'key', the communication becomes more secure because substitution and replay are ruled out.	

**Notes tab**

Use this screen to log information unique to each account. This information is for reference only.

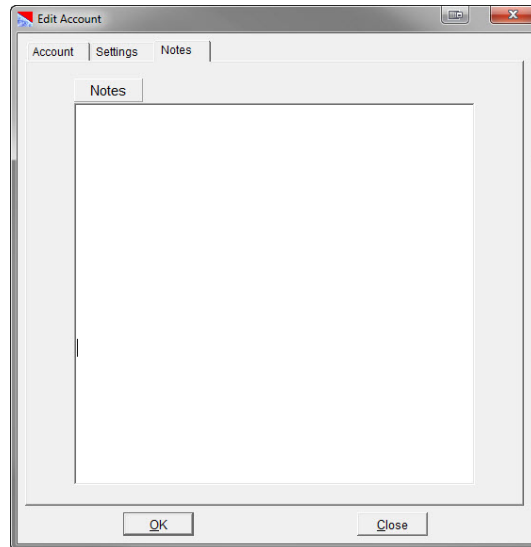



### Copy an Account

This command can be accomplished by using the D6200 Programming Software.  
To copy an account:

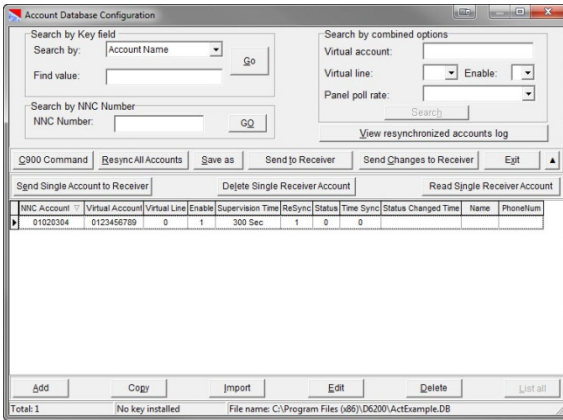

1. select an existing account



- 2.

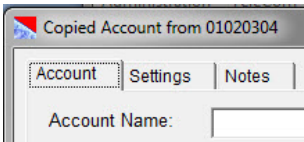

Any Account information from the copied account is transferred to the copy with only the NNC number remaining blank.

3. **Network Device:**

and select the proper device from the drop-down menu.

- 4.

5. **NNC Number:**   
(Area 1 Account Number)

Enter the NNC number for this new account.

6. Enter the correct Virtual Account number and other required information if it is different from the copied account.

7. If this is a new account, be sure that ReSynchronization is set to **Yes**.

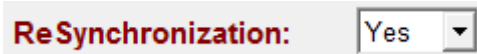

- 8.

### Import an Account

You can import an account only by using the D6200 Programming Software.  
To import an account from another database:

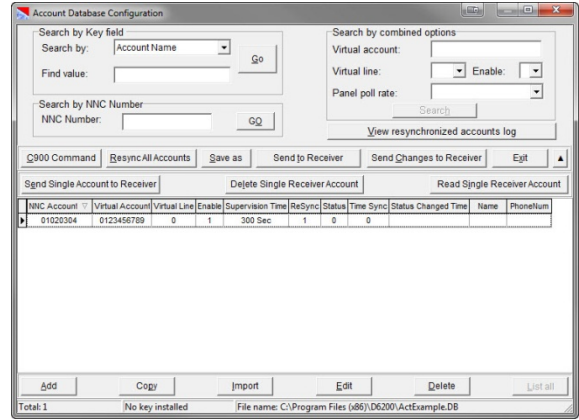

- 1.

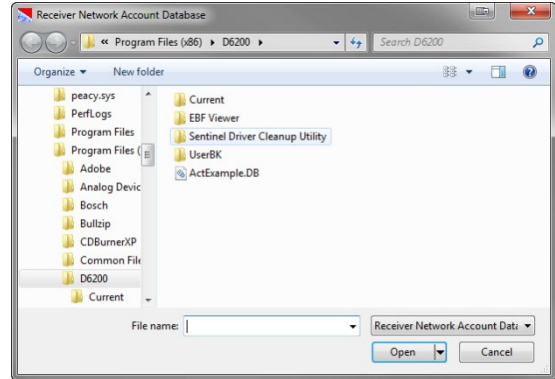

2. Select the database where the source account(s) to be copied reside.

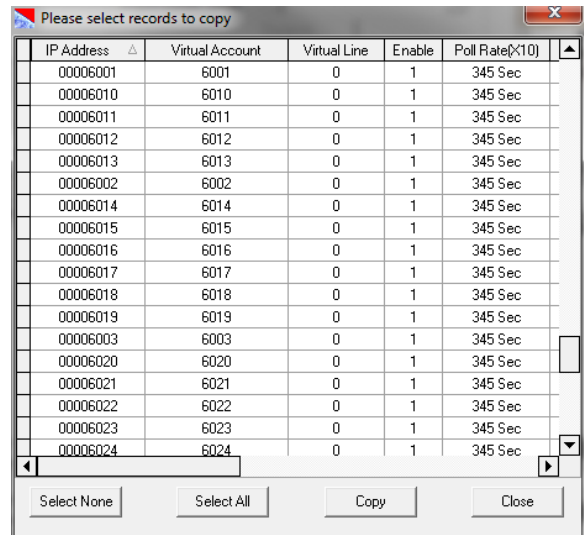

3.



IP Address	Virtual Account	Virtual Line	Enable	Poll Rate(x10)
00006001	6001	0	1	345 Sec
00006010	6010	0	1	345 Sec

To select more than one account in different parts of the list, highlight the first one and then hold down the [Ctrl] and click the second one, the third one, and so on.  
To select a series of accounts, highlight the first one, hold down the [Shift] key and click the last desired account.

4.

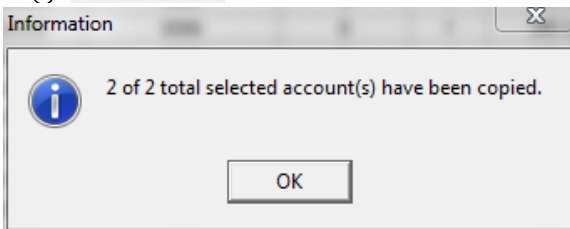
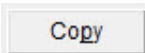

5.



Duplicate account numbers are not imported.

6.

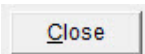

Virtual Account	Virtual Line	Enable	Supervision Time	ReSync	Status	Time Sync	Status Changed Time	Name	Phone#	Account #
6001	0	1	345 Seconds	1	0	0				00006001
6010	0	1	345 Seconds	1	0	0				00006010
0123456789	0	1	300 Seconds	1	0	0				0123456789

## Delete an Account

Deletes the selected account(s) from the database.

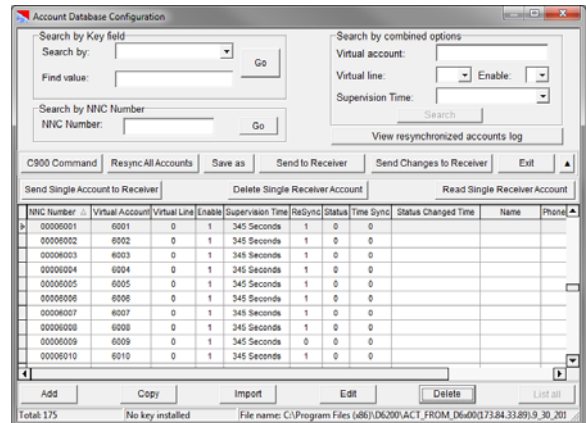

1.



00006001	6001	0	1	345 Seconds
----------	------	---	---	-------------

To select more than one account in different parts of the list, highlight the first one and then hold down the [Ctrl] and click the second one, the third one, and so on.  
To select a series of accounts, highlight the first one, hold down the [Shift] key and click the last account.

2.

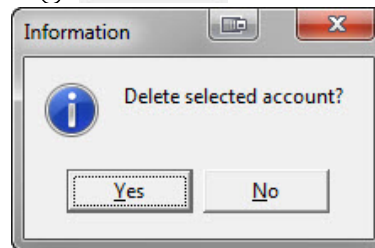
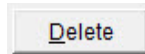

3.

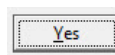

Deletes the selected account(s).

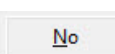

Cancels the delete operation.

The account is deleted and disappears from the list of accounts.

### Saving the Database with a New Name

Network account database files can be saved with a different file name but only within the database file.

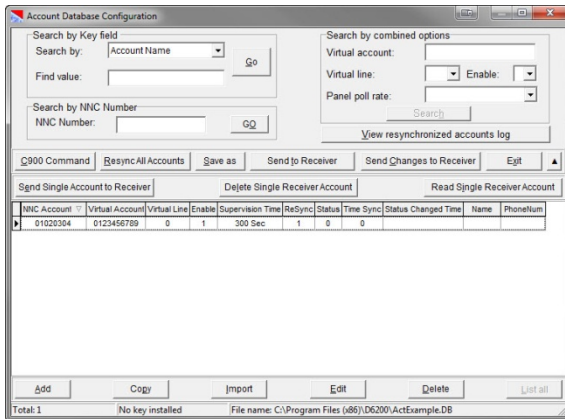

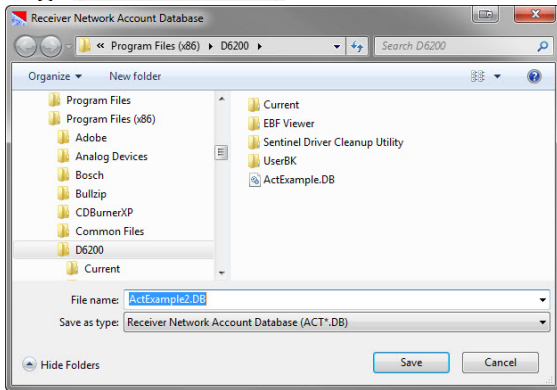
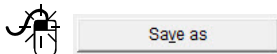

1.

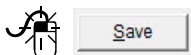

2. Type the new name.

3.



 The new name for the account database file must begin with ACT; otherwise, the following error occurs:

**Error**

Account database file must be named in this format: 'ACTxxxx.DB'

OK

### Sending the Database

Send the database back to the receiver after modifying it from the D6200 interface for the changes to take effect. There are two options for sending the account database:

1. **Send Changes to Receiver** – Send only new or changed network account entries.
2. **Send to Receiver** – This sends the entire network account database.

Starting with v2.0 of D6200, sending only changes to the network account database can be performed. If the receiver does not currently have a network account database loaded into it or if the power has been cycled, **Send to Receiver** must be used to send the entire database to the receiver. If changes or new accounts are added to a network account database already in use, then **Send Changes to Receiver** can be used.

 The **Send Changes to Receiver** can only be used in the current session. If changes are made and saved to a database, it is closed and then later re-opened, then the entire database will need to be sent to the receiver.

Network account databases that are modified and changes only can be sent will show the modified account in this manner:

table	Supervision Time	ReSync	Status	Time Sync	Status Changed Time	Name	PhoneNum	Account IP	Account Port	Flag
1	200 Seconds	1	0							New
1	345 Seconds	1	0	0						
1	345 Seconds	1	0	0						Changed

A new account will be green in color and have a flag of New. A modified account will be blue in color and have a flag of Changed.

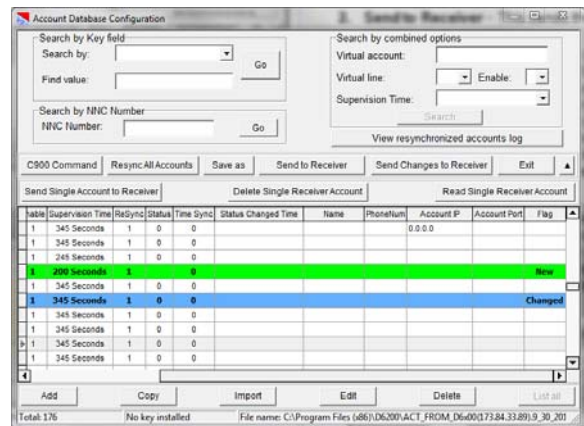

1.

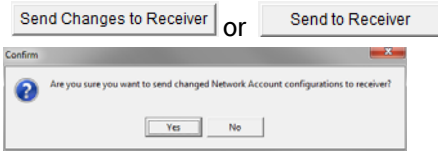

Or

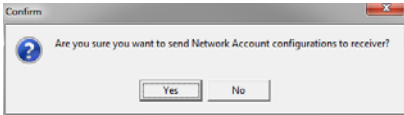

Continues with sending the database to the receiver.

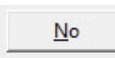

Cancels the sending operation.

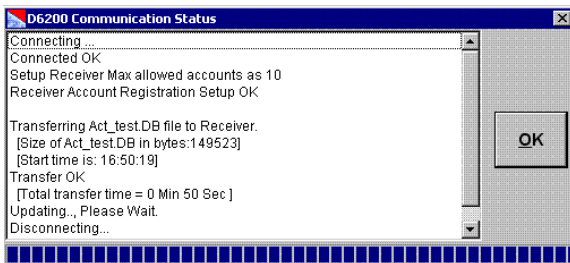

2.



### 3.8.4 Modifying individual accounts

Starting with v2.00 of D6200 with the latest version of software in the receivers, there are new options that enable the ability to:

- Send Single Account to Receiver
- Delete Single Receiver Account
- Read Single Receiver Account

#### Send Single Account to Receiver

This allows for a single account from a network account database to be sent to a receiver.

Start by either receiving or opening an existing network account database.

1. Select the account to be sent to the receiver.

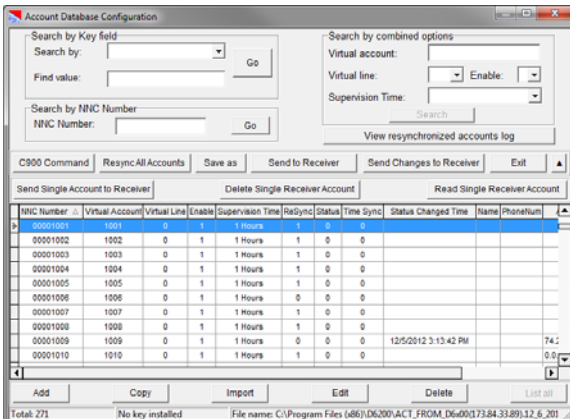

If required, make changes to the account record and save the changes back to the database.

2.

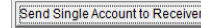

3.

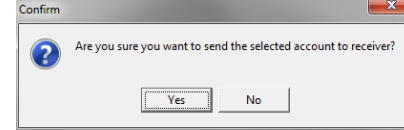

Click **Yes**.

#### Delete Single Receiver Account

This allows for a single account from a network account database to be deleted from a receiver.

Start by either receiving or opening an existing network account database.

1.

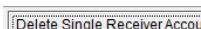

2.

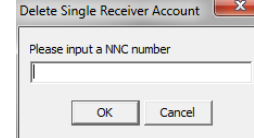

Enter the NNC number of the account to be removed and click **OK**.

3.

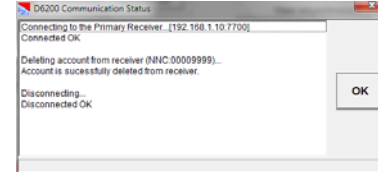

Click **OK**.

4.

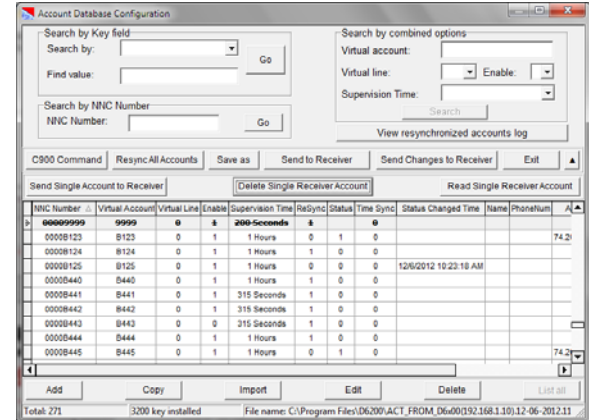

Click **Exit** to exit the database. It will confirm that you want to save the changes to the database.

5.

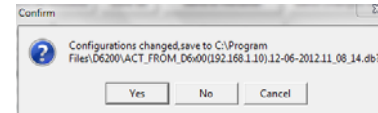

Click **Yes** to save the changes back to the open database.

### Read Single Receiver Account

This allows for the settings and current status of a single account from a network account database to be read from a receiver without receiving the entire database.

Start by opening an existing network account database.

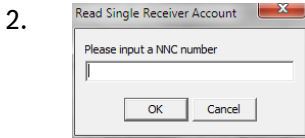
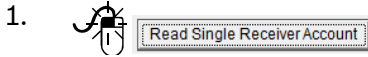

Enter the NNC number of the account to be read and click **OK**.

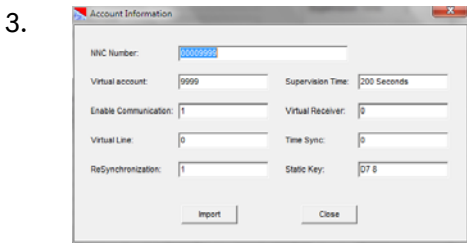

Click **Import**.

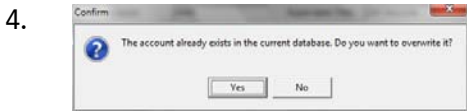

Click **Yes** to confirm the import and receive the current settings and status.

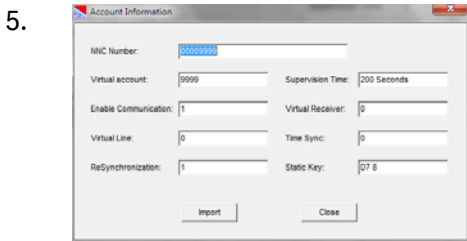

Click **Close** to complete the Import.

### 3.8.5 Searching for Account

Three options are available in the D6200 Programming Software when searching for an account. Search by:

- Key field
- NNC Number
- Combined options

**Figure 13: Account Database Search Options**

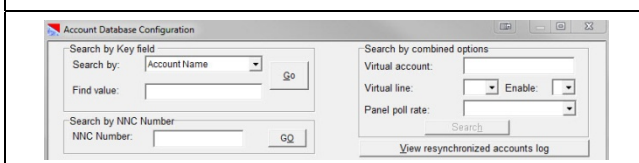

### Search by Key Field

Any of the account fields can be used to search for a particular text string.

**Figure 14: Search by Key field**

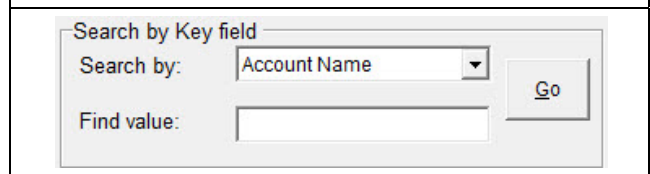

Available fields in the “Search by:” drop down list:

- |                      |                     |
|----------------------|---------------------|
| • Account Name       | • Contact 1         |
| • Administrator      | • Telephone         |
| • Virtual Account    | • Contact 2         |
| • Control panel Type | • Contact 2         |
| • Control panel      | • Telephone         |
| • Communication      | • Contact 3         |
| • Format             | • Contact 3         |
| • Zip                | • Telephone         |
| • Phone Number       | • Contact 4         |
| • Fax Number         | • Contact 4         |
| • Contact 1          | • Telephone         |
|                      | • Contact 5         |
|                      | • Contact 5         |
|                      | • Telephone         |
|                      | • Time Sync         |
|                      | • Resynchronization |

Use the “Find value:” field to enter a specific text string.

Click the **GO** button to search.

### Search by NNC Number

Find an account by a specific NNC number as the criteria.

The search box uses NNC number.

Enter the NNC number and click the **GO** button to start the search.

### Search by Combined Options

Virtual Account, Virtual Line, Enable, and Control Panel Poll Rate search options are available in combination to find an account.

**Figure 15: Search by combined options**

The screenshot shows a search form titled "Search by combined options". It contains four input fields: "Virtual account:" (a text box), "Virtual line:" (a dropdown menu), "Enable:" (a dropdown menu), and "Panel poll rate:" (a dropdown menu). Below these fields is a "Search" button.

Click the **View resynchronized accounts log** button to view a log of the last time accounts were synchronized [refer to **Anti-Substitution (Resynchronization)** on page 32] between the D6200 and the receiver.

### 3.8.6 C900 Commands

The D6200 can send commands to active and enabled C900TTL-E or C900V2 modules on the network.

**Figure 16: C900 Commands**

The screenshot shows the "Account Database Configuration" window. It has a "Search by Key field" section with "Account Name" selected and a "Go" button. Below it is a "Find value:" field. There is also a "Search by NNC Number" section with an "NNC Number:" field and a "GO" button. On the right, there is a "Search by combined options" section with dropdowns for "Virtual account:", "Virtual line:", "Enable:", and "Panel poll rate:", along with a "Search" button and a "View resynchronized accounts log" button. Below the search options are several buttons: "C900 Command", "Resync All Accounts", "Save as", "Send to Receiver", "Send Changes to Receiver", and "Exit". There are also buttons for "Send Single Account to Receiver", "Delete Single Receiver Account", and "Read Single Receiver Account". A table is displayed with the following columns: NNC Account, Virtual Account, Virtual Line, Enable, Supervision Time, ReSync, Status, Time Sync, Status Changed Time, Name, and PhoneNum. The table contains one row of data: N 01020304, 0123456789, 0, 1, 300 Sec, 1, 0, 0, Status Changed Time, Name, PhoneNum. At the bottom, there are buttons for "Add", "Copy", "Import", "Edit", "Delete", and "List all". The status bar shows "Total: 1", "No key installed", and "File name: C:\Program Files (x86)\D6200\ActExample2.DB".

NNC Account	Virtual Account	Virtual Line	Enable	Supervision Time	ReSync	Status	Time Sync	Status Changed Time	Name	PhoneNum
N 01020304	0123456789	0	1	300 Sec	1	0	0	Status Changed Time	Name	PhoneNum

These commands (accessed from inside an open Network Account Database) are in two categories:

- Dialer Status
- Transmission rate

To send a C900 command, refer to *Changing C900 Transmission Settings and Retrieving C900 Status* on page 40.

**Figure 17: C900 Control Commands window**

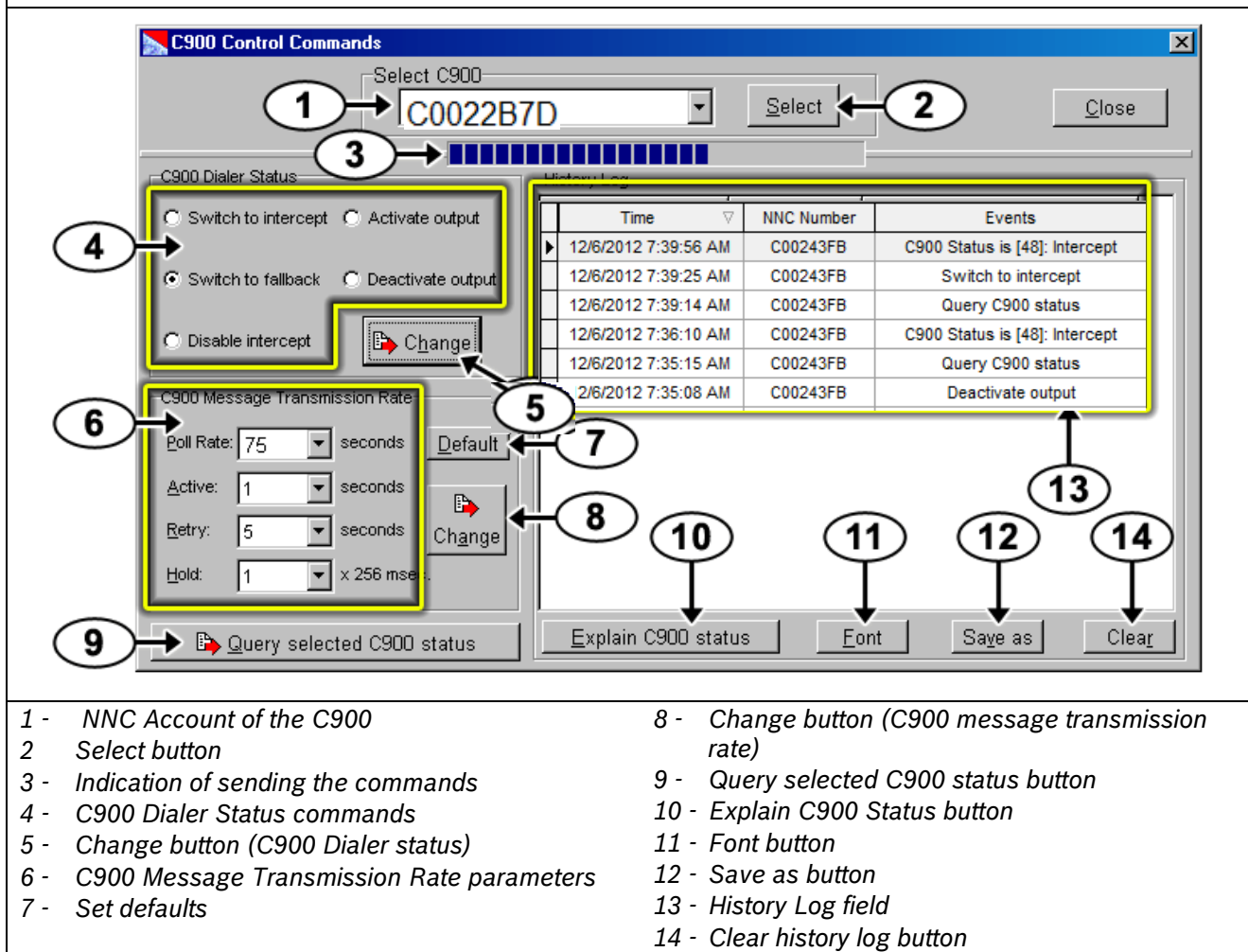

- 1 - NNC Account of the C900
- 2 - Select button
- 3 - Indication of sending the commands
- 4 - C900 Dialer Status commands
- 5 - Change button (C900 Dialer status)
- 6 - C900 Message Transmission Rate parameters
- 7 - Set defaults
- 8 - Change button (C900 message transmission rate)
- 9 - Query selected C900 status button
- 10 - Explain C900 Status button
- 11 - Font button
- 12 - Save as button
- 13 - History Log field
- 14 - Clear history log button

Select a C900 NNC account from the **Select C900** drop down menu by first using the **Select** button (Item 2 in Figure 17).

Modify the C900 Dialer Status (Item 4 in Figure 17) and C900 Message Transmission Rate (Item 6 in Figure 17) parameters after selecting a C900. Click the **Change** button (Item 5 and Item 8 in Figure 17) to send the commands to the C900. Sending of the commands is shown by a slowly advancing taskbar (Item 3 in Figure 17).

After the C900 polls the receiver, the D6200 delivers the commands to the C900. When a command is scheduled for delivery to the C900 and the poll rate is set for 30 sec, the command delivery might take up to 30 sec. When the history log displays (Item 13 in Figure 17) the ACK from the C900, the module operates according to the command that was sent.



If more than one command is queued for a specific module within a single poll period, the C900 recognizes only the last queued command. All other commands are ignored by the C900.

The Poll Rate listed in the **C900 Transmission Rate** section (Item 6 in Figure 17) is the poll rate the C900 uses if that command is sent to a C900TTL-E or C900V2 overriding the DIP switch poll rate setting. To maintain polling synchronization, consider the Account Database Poll Rate to track this modified C900 polling rate.

The history log screen displays all C900 control activity including sent commands, receiver ACKs to changed commands, and status inquiries. The history log screen can be used as a C900 control programming record.



If the C900 reboots or loses power, any C900 Dialer Status or C900 Transmission Rate changes sent to that C900 are lost from that C900's memory, which reverts to its default DIP switch settings. After the reboot, send the changes again to the C900 to resume operation.  
Save the History Log after sending commands to any C900.

**Save as**

This button saves a copy of the current history log field (*Item 13 in Figure 17 on page 39*).

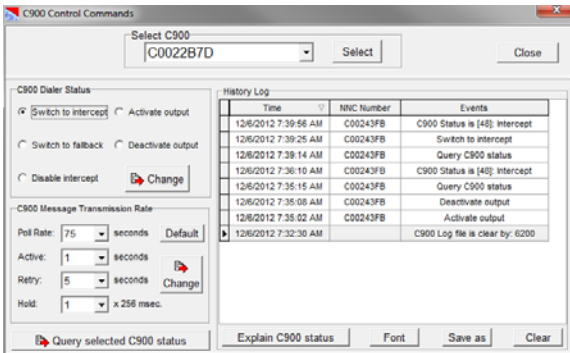

1.

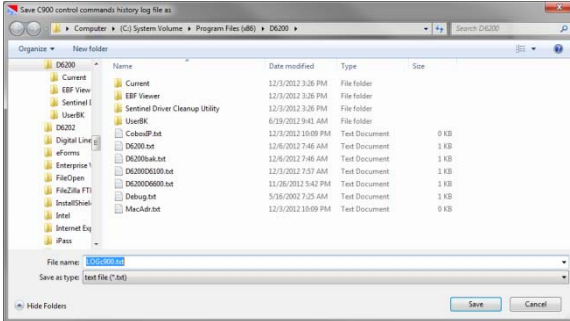
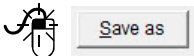

2. Type a new name for the log file.

3.



**Changing C900 Transmission Settings and Retrieving C900 Status**

The printer records all commands and related C900 status changes that are also sent to the automation software. The D6200 sends Low Battery, Reboot, and Dialer Diagnostic C900 status messages first to the receiver and then to the automation software and printer.

1.

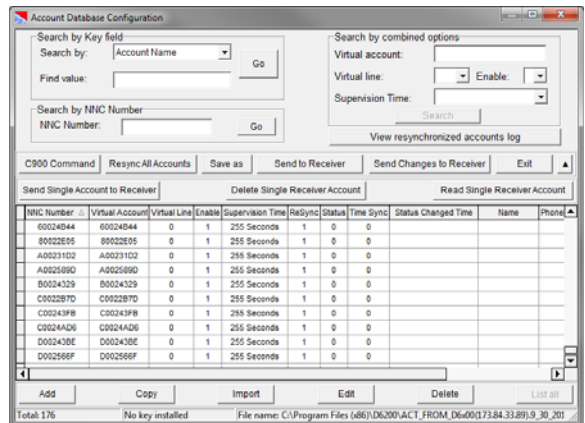
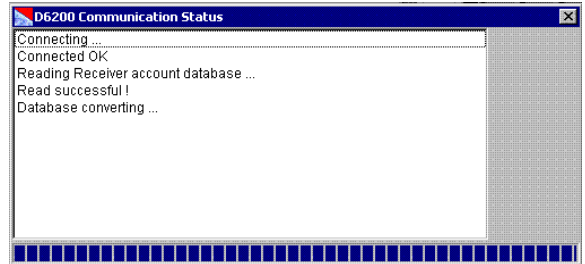
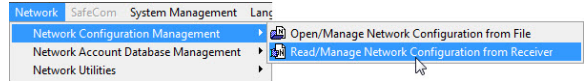

2.

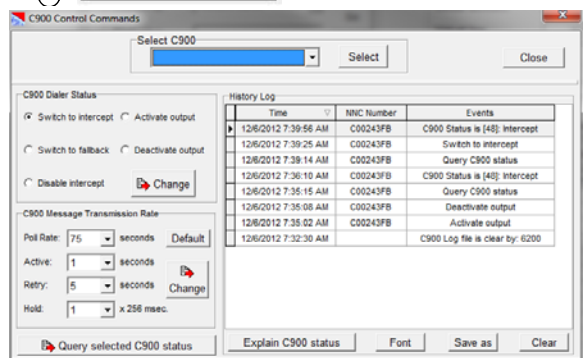
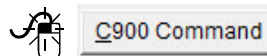



3.

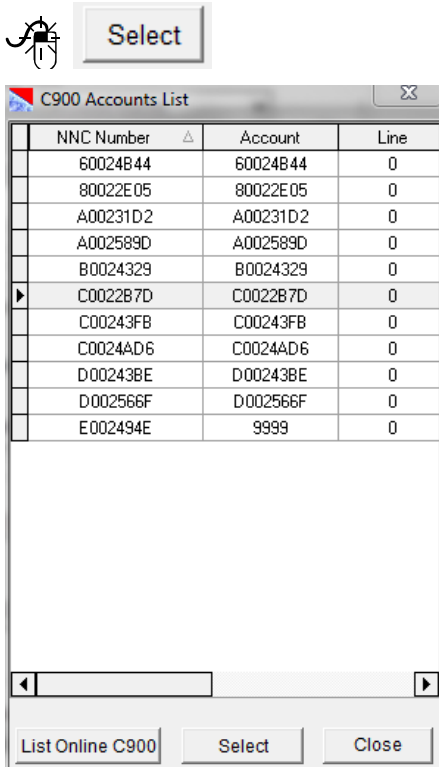

Highlight the C900 account the account to make changes to. To only list accounts that are online (Status 1), click **List Online C900**.

4.

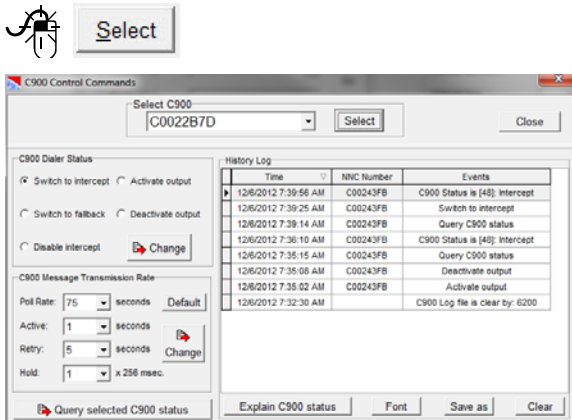

The status of a C900 might have changed since the last time the Account database was read from the receiver. For an accurate C900 Account status, import the Account database from the D6600 before making any C900 changes.



C900 Status must be 1 to send a command to that C900.

5.

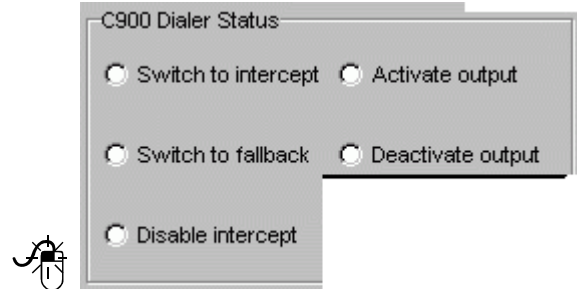

(Refer to Table 3 on page 42)

6.

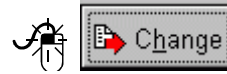

The D6200 sends this command to the receiver. On the next poll, the receiver retransmits the command to the C900.

The history log file records all status changes.

7.

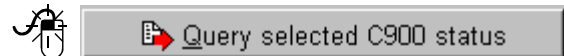

The last command sent to the C900 appears in the history log display upon the next poll the D6600 receives from the C900.

12/6/2012 7:39:14 AM	C00243FB	Query C900 status
12/6/2012 7:36:10 AM	C00243FB	C900 Status is [48]: Intercept

8.



For a more detailed explanation.

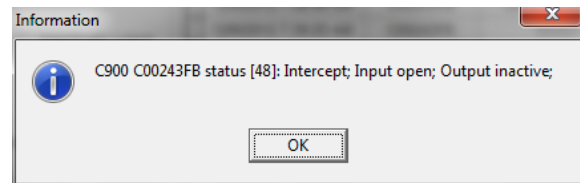



### C900 Command Descriptions

The following sections describe these control commands.

Refer to *Appendix D: Network Messages* in the *D6600/D6100IPv6 Computer Interface Manual* (P/N: 4998122703) for receiver messages output descriptions for these commands.

**Table 3: C900 Command Descriptions**

Command Name		Description
Switch to Intercept	<input checked="" type="radio"/> Switch to intercept	Causes the C900 to work in the Intercept mode and allows the C900 to receive the dialer signals and sends them to the D6600 through a LAN/WAN.
Switch to Fallback	<input checked="" type="radio"/> Switch to fallback	Causes the C900 to work temporarily in the fallback mode, so the dialer can use the PSTN to communicate with the central stations that remotely control the dialer for PSTN remote programming. If a C900 is switched to fallback, an optional message can be created every 30 min reminding the operator that the C900 is in the fallback mode and might return to the intercept mode for LAN/WAN communications. The C900 automatically switches to Intercept after one hour of switching to fallback or turns to Intercept mode immediately upon receiving the command Switch to Intercept.
Disable Intercept	<input checked="" type="radio"/> Disable intercept	Remotely removes a defective C900 from service. The dialer is connected to the PSTN until the Intercept command is enabled or the C900 reboots.
Activate Output	<input checked="" type="radio"/> Activate output	Activates Output 4 on the C900 (an open collector output) when connected to annunciating devices or directly to a control panel input to signal various conditions.
Deactivate Output	<input checked="" type="radio"/> Deactivate output	Deactivates Output 4 on the C900 (an open collector output) when connected to annunciating devices or directly to a control panel input to signal various conditions.
Poll Rate	Poll Rate: 75	 Upon rebooting, the C900 reverts to the DIP switch settings for the poll rate. For UL Fire Listed, the poll rate should be 240 sec. C900 v1.09 or less has a 30-sec default poll rate when DIP Switch 7 is in the OFF position. C900 v1.10 or greater has a 75-sec default poll rate when DIP Switch 7 is in the OFF position.
Active (C900 Acknowledgement from Dialer)	Active: 1	Specifies the wait before the C900 receives the acknowledgment or other information from the dialer. The C900 waits for the dialer to respond to the handshake. A valid entry is 0 to 255. Entering a 0 uses the default of 1 sec.
Retry (Elapsed Wait Time)	Retry: 5	Specifies the wait in seconds before the C900 responds to a message, sending the command again.   The C900 retries nine times before deciding that the host has failed. Valid entry is 0 to 255. Entering a 0 uses the default of 5 sec. Resend this value to the C900 after the C900 reboots.
Hold (Before Transmitting Message)	Hold: 1 x 256 msec.	Specifies the wait (in 256 ms increments) after the C900 receives any message before it transmits another message. Valid entries are from 0 to 255. Entering 0 uses the default of 256 ms.

### 3.9 Network Utilities

#### 3.9.1 Show Account Status

Using this command, the operator views all the accounts in the database in a summary form. Read the database from the receiver into the D6200 for updated account status.

The summary the following account information:

- IP Address
- Status
- Status Changed Time
- Anti-Sub
- Poll Rate
- Virtual Account Number
- Name

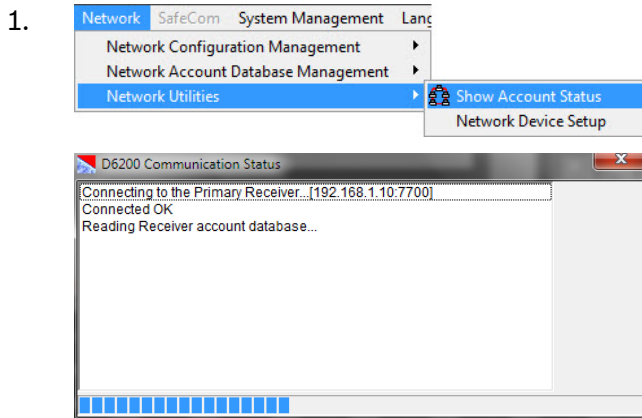

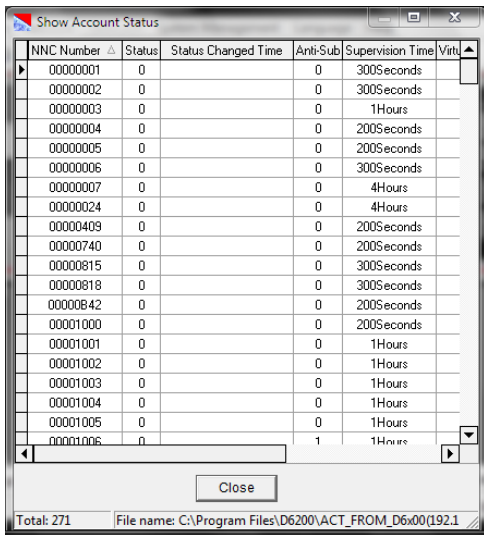

NNC Number	Status	Status Changed Time	Anti-Sub	Supervision Time	Virtu
00000001	0		0	300seconds	
00000002	0		0	300seconds	
00000003	0		0	1Hours	
00000004	0		0	200seconds	
00000005	0		0	200seconds	
00000006	0		0	300seconds	
00000007	0		0	4Hours	
00000024	0		0	4Hours	
00000409	0		0	200seconds	
00000740	0		0	200seconds	
00000815	0		0	300seconds	
00000818	0		0	300seconds	
00000842	0		0	200seconds	
00001000	0		0	200seconds	
00001001	0		0	1Hours	
00001002	0		0	1Hours	
00001003	0		0	1Hours	
00001004	0		0	1Hours	
00001005	0		0	1Hours	
00001006	0		1	1Hours	

Total: 271 File name: C:\Program Files\D6200\ACT\_FROM\_D6x00(192.1



show more summary details



Closes the window.

#### 3.9.2 Network Device Setup

Using this command, the user can configure other connected network devices such as the D6682/D6680, D6686/D6100IPv6, DX4020, C900V2/C900TT-E, and D9133TTL-E.



If these automated commands do not work properly, refer to *Section 5.2 Assigning IP Addresses Using Telnet* on page 58 to connect to the device manually using telnet, assign the IP address, and ping the IP address.



For the D6686 and D6100IPv6, they will use the XML Configuration tab for setup. For the details of programming a D6686 or D6100IPv6 using the XML tab, please refer to the Installation and Operation manuals for those products.

*D6686 Installation Guide (P/N: F01U269888)*  
*D6600/D6100IPv6 IOG (P/N: 4998122704)*

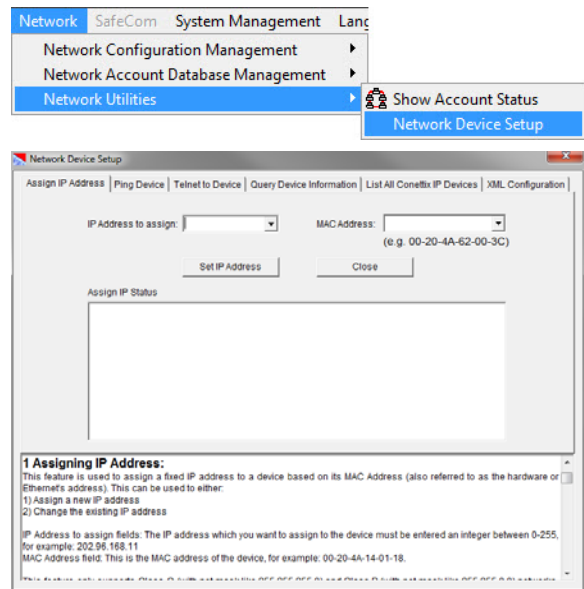

- **Assign IP Address** – refer to page 44
- **Ping Device** – refer to page 44
- **Telnet to Device** – refer to page 44
- **Query Device Information** – refer to page 45
- **List All Conettix IP Devices** – refer to page 45

## Assign an IP Address

**Figure 18: Network Device Setup – Assign IP Address**

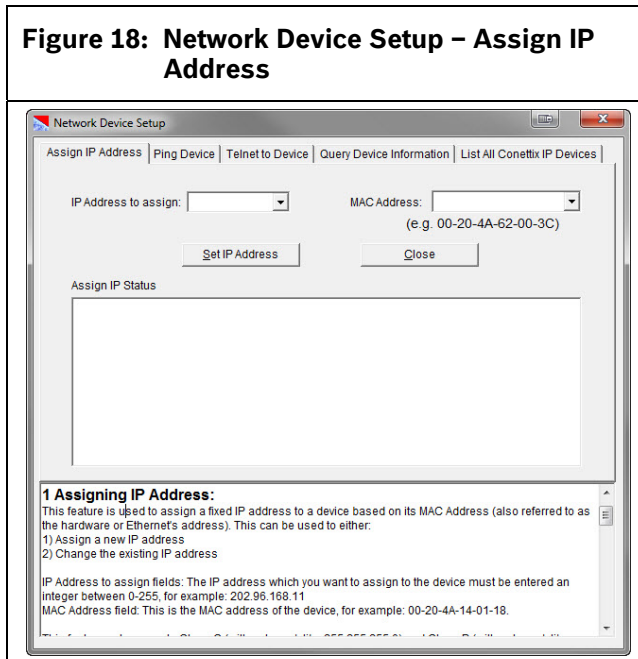

The user can:

- select or enter an IP address from a drop-down menu of IP addresses
- select or enter a MAC address from a drop-down menu of MAC addresses
- set the IP Address after it is chosen

The bottom of the window shows online help and provides additional information to guide the user.

### Ping Device

In *Figure 19*, the ping utility verifies the IP address of the network device.

**Figure 19: Network Device Setup – Ping Device**

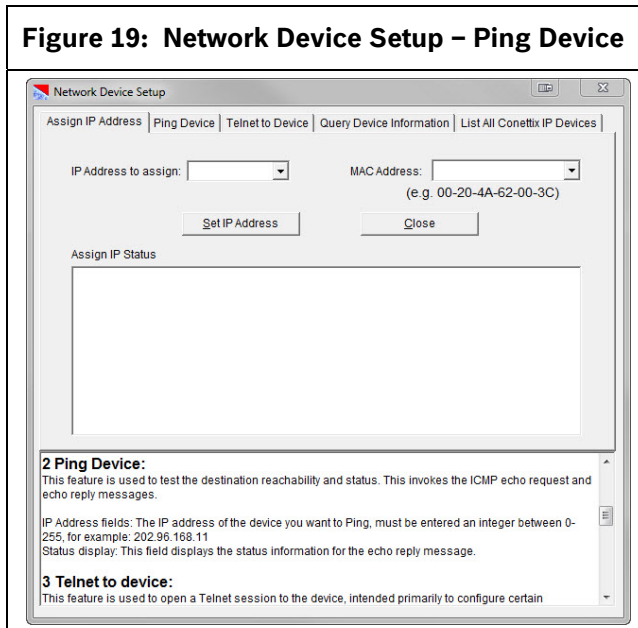

The user can:

- enter an IP address or select from a drop-down menu of IP addresses
- enter a timeout interval in milliseconds before the IP address is pinged again
- ping the device to verify communication

The bottom of the window shows online help and provides additional information to guide the user.

### Telnet to Device

In *Figure 20*, the user connects to the network device using the telnet program.

**Figure 20: Network Device Setup – Telnet to Device**

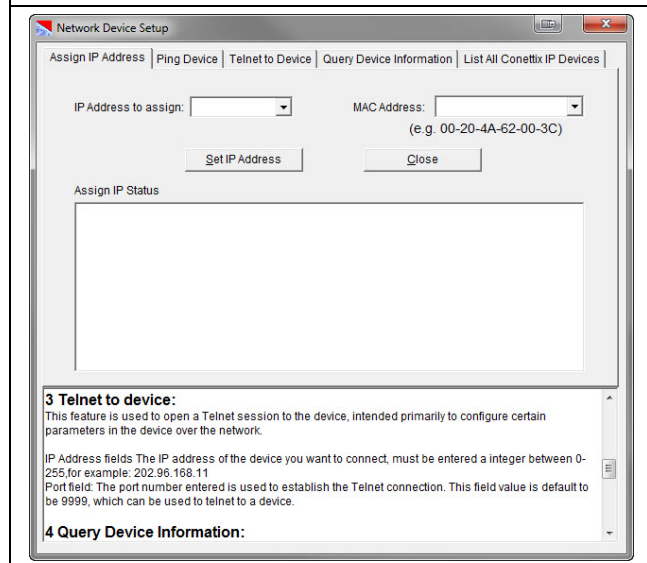

The user can:

- enter an IP address or select from a drop-down menu of IP addresses
- enter port number or select from a drop-down menu of port numbers
- initiate a telnet session to communicate with the device

The bottom of the window shows online help to guide the user and provides additional information.

For more information, refer to the following installation guides:

- C900TTL-E: *C900TTL-E Installation Guide* (P/N: 4998122718)
- D9133TTL-E: *D9133TTL-E Installation Guide* (P/N: 4998122717)
- C900V2: *Conetrix C900V2 Installation Guide* (P/N: F01U003472)
- DX4020: *Conetrix DX4020 Installation Guide* (P/N: F01U045288)

### Query Device Information

In *Figure 21*, the user requests and receives information about a network device.

**Figure 21: Network Device Setup – Query Device Information**

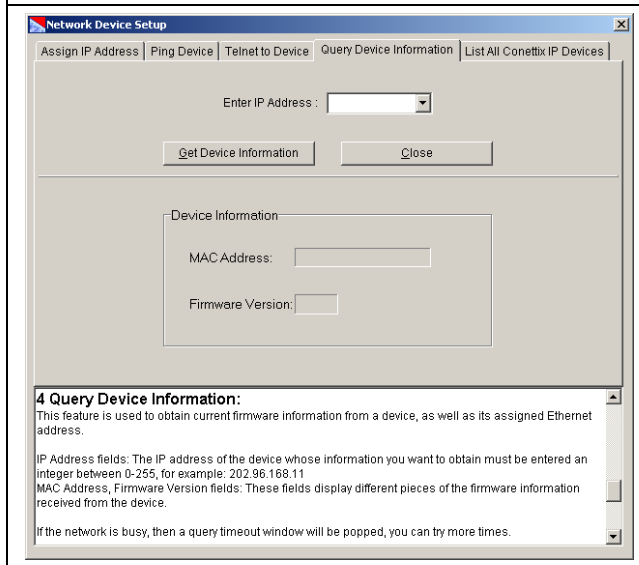

The user can:

- enter an IP address or select from a drop-down menu of IP addresses
- request information about the device at the IP address.

### List All Conetix IP Devices

In *Figure 22*, the user gets a list of all online network devices in the current LAN. If detected, the MAC address and IP address of the devices appear if they are detected.

Click **Save** to save the MAC and IP information to a text file after all online network devices in the LAN appear.

**Figure 22: Network Device Setup – List All Conetix IP Devices**

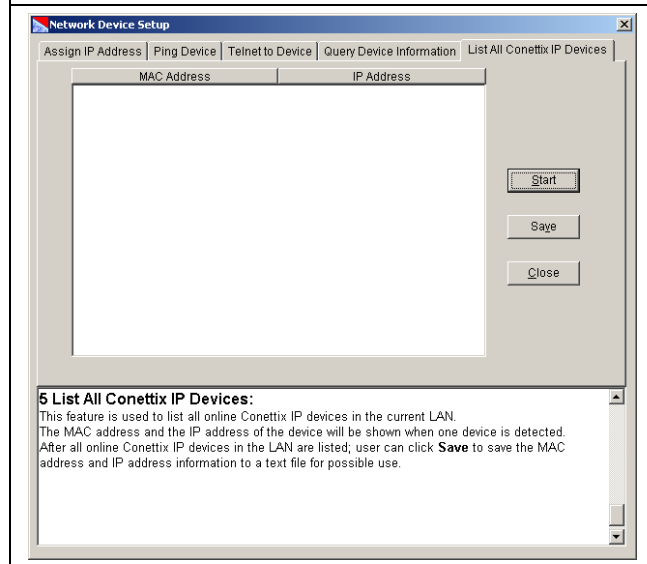

## 3.10 System Management

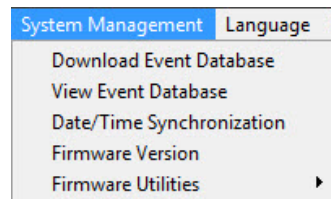

- **Download Event Database** – Sends all the events that have occurred in the D6600/D6100IPv6 Receiver to the PC running the D6200 Software and saves it to a file.
- **Date/Time Synchronization** – Sets the time and date on the receiver to the time and date on the PC.
- **Firmware Version** – Connects the D6200 to the receiver and retrieves all the version numbers for the firmware running on the D6600/D6100IPv6. Refer to *Section 3.10.3 Firmware Version* on page 48.

### 3.10.1 Event Database

You can receive the event database from the D6600/D6100IPv6 Receiver and save it as a file to the PC that is running the D6200 Software.



Bosch Technical Support uses the event database file to troubleshoot problems.

Use the D6200 software to download the database and save it to the host PC:

1.
  - System Management
  - Language
  - Download Event Database
  - View Event Database
  - Date/Time Synchronization
  - Firmware Version
  - Firmware Utilities

**Figure 23: D6200 Communication Status Window - Download Event Database**

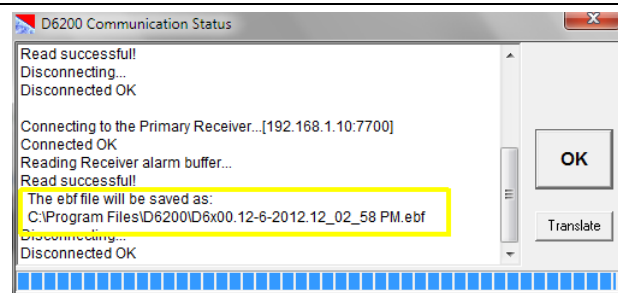

Filename and path of saved database file.

- 2.

#### Translate Button

Clicking the Translate button opens the **Event Database Viewer** (Figure 24) program (EBF Viewer).

**Figure 24: Event Database Program Open**

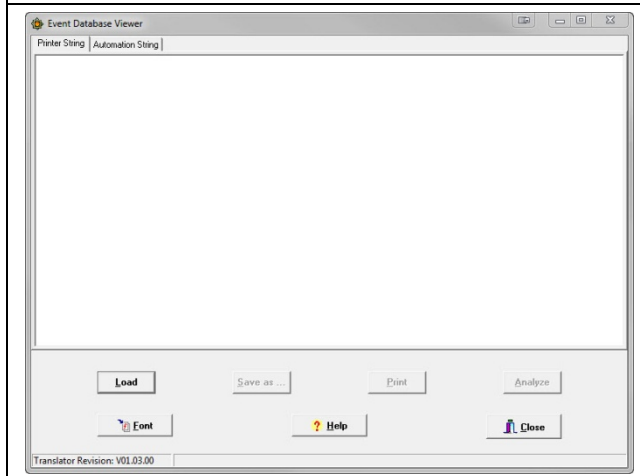

The EBF Viewer can also be opened by clicking the **View Event Database** selection in the **System Management** menu to load previously received EBF files. By using the Translate button, the file is automatically loaded into the EBF Viewer. Here is an example of the main page from the EBF Viewer:

**Figure 25: EBF Viewer**

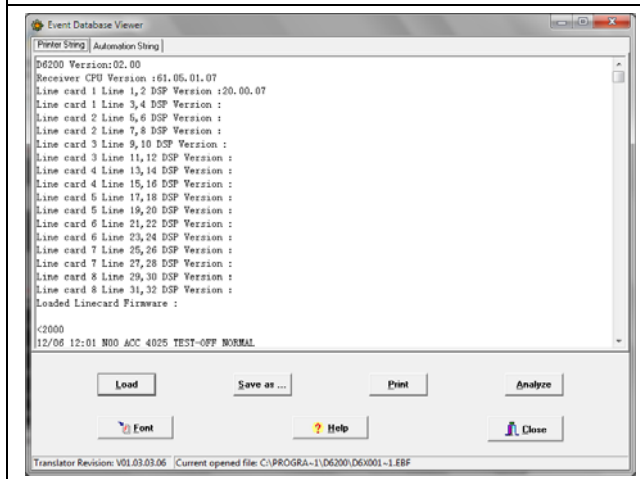

In the viewer, you can view all of the events that were sent to the printer and automation. The printer events appear in the following format:

```
<1999
04/28 16:01 N00 ACC 0101 FIRE TBL RESTOR
+++ACC 0101      AREA=1 POINT=002
+++ACC 0101      2
```

The automation events appear in the following format:

```
1999: {10}B0C02D[9]20020100[#0101|Nri1/FJ002/
A2ssssssssssss][13]
```

These two examples show from Account # 0101 a Fire Trouble Restore in Area #1, Point #002, with Point Text from the control panel of point 2. This data can be helpful to find details of a message that might be missing, or show an error in automation.

The options in the viewer are:

- **Load** – Allows a previously saved EBF file to be loaded
- **Save as** – Option to save the open EBF file as a text file
- **Print** – Option to print the open EBF file
- **Analyze** – Statistical data analysis (described in detail below)
- **Font** – Selects the font that the EBF is viewed in
- **Help** – User help on the operation of the EBF Viewer
- **Close** – Close the EBF Viewer

The Analyze feature in the EBF Viewer is a powerful statistical tool. To use it, click the Analyze Button. The program analyzes all of the data and presents the statistics in the Analyze window (Figure 26).

Figure 26: Analyze Window

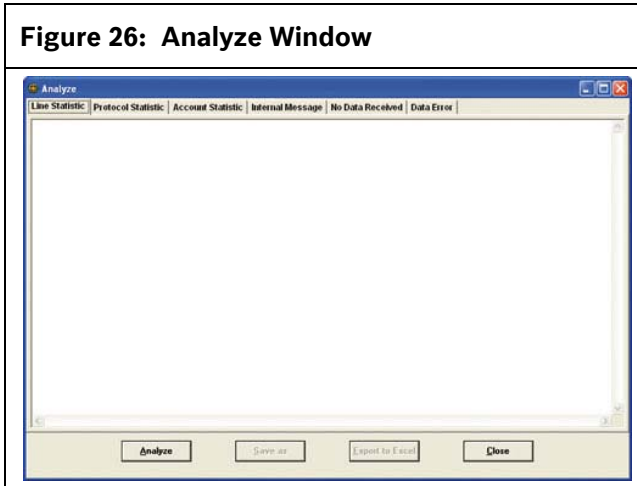

In the Analyze window there are six tabs that show all of the statistics. They are:

- **Line Statistics** – This tab shows a summary of all the PSTN Calls that have been taken by the receiver, how many No Data Received messages (NDRs) occurred, how many Data Errors occurred, followed by a line-by-line breakdown of the data.

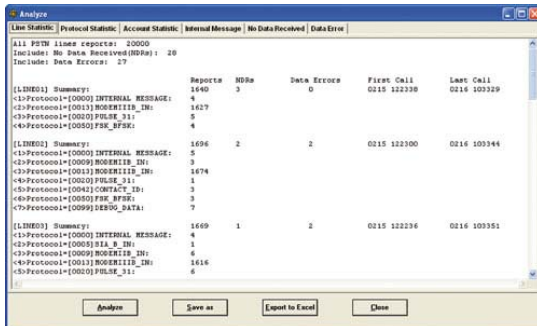

- **Protocol Statistics** – This tab shows the number of unique protocols that were received, and then a summary of the number of events for each protocol.

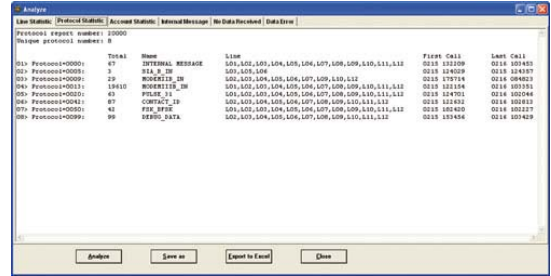

- **Account Statistics** – This tab show the number of events that were received from network accounts and the number of unique network accounts loaded in the receiver.

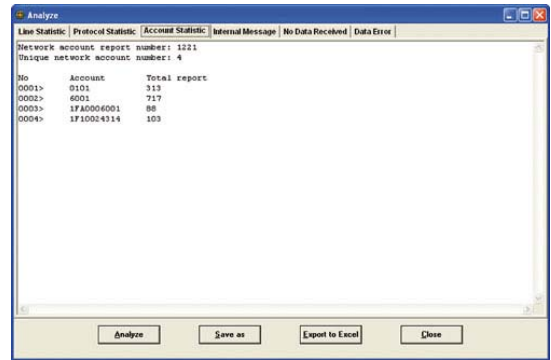

- **Internal Message** – This tab shows a summary and details of all of the messages generated by the receiver such as Time Set, Date Set, Computer Error, and so on.

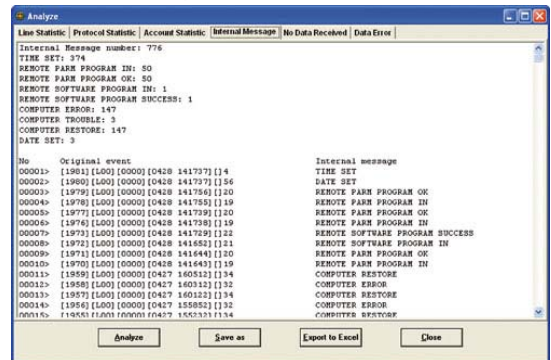

- **No Data Received** – This tab shows a summary and details of the NDR messages in the receiver.

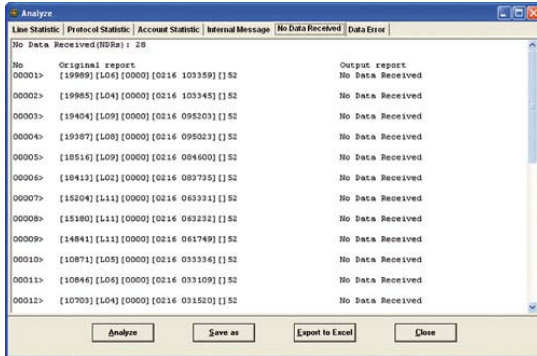

- **Data Error** – This tab shows a summary and details of all data errors received from incoming PSTN calls.

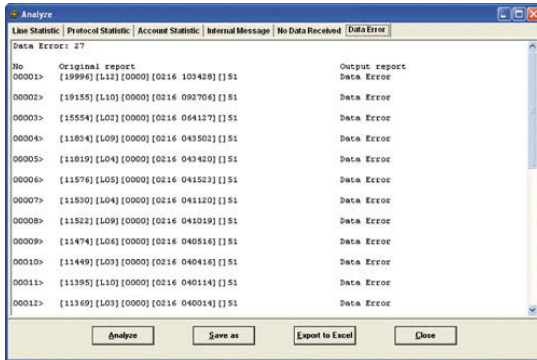

### 3.10.2 Date/Time Synchronizations

You can use the D6200 Programming Software package to synchronize the receiver's time with the PC's time.

- 1.

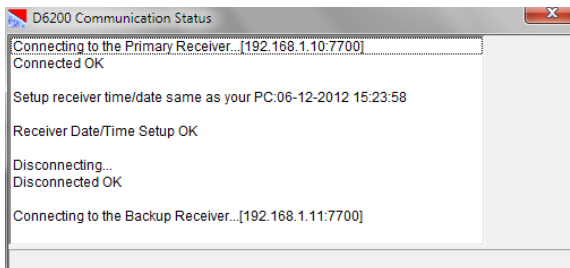

- 2.

### 3.10.3 Firmware Version

Use this command to determine the receiver's firmware version.

- 1.



The version numbers presented in this example are for illustration only and can differ from your receiver's version numbers.

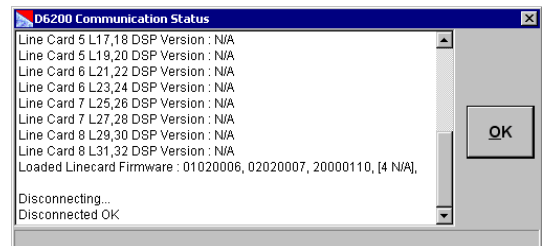
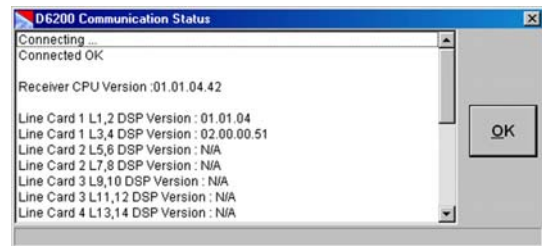

- 2.



### 3.11 Firmware Utilities

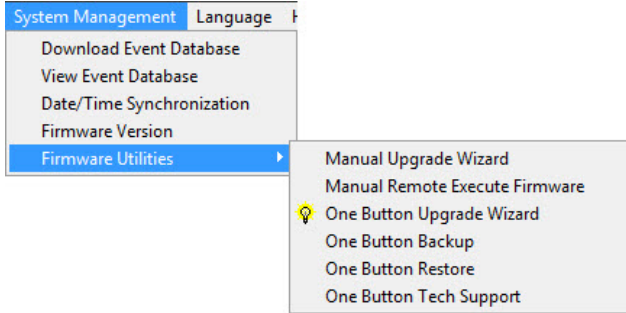

- **Manual Upgrade Wizard** - Manual process of decompressing firmware upgrade files on PC then using D6200 to install the new versions. Refer to *Section 4.0 Upgrading the Software* on page 51.
- **Manual Remote Execute Firmware** –A command sent to execute the software upgrade after copying files to the receiver.
- **One-Button Operations** - Automated commands to:
  - upgrade firmware (refer to *Section 4.1 Performing a One-Button Upgrade* on page 51)
  - back up configurations and databases
  - restore configurations and databases
  - prepare files to send to Bosch Technical Support for troubleshooting

#### 3.11.1 One Button Backup

With this feature (*Figure 27*), the D6200 guides the user through backing up all the files necessary to either reinstall the user configurations and databases later or document changes.

**Figure 27: One Button Backup**

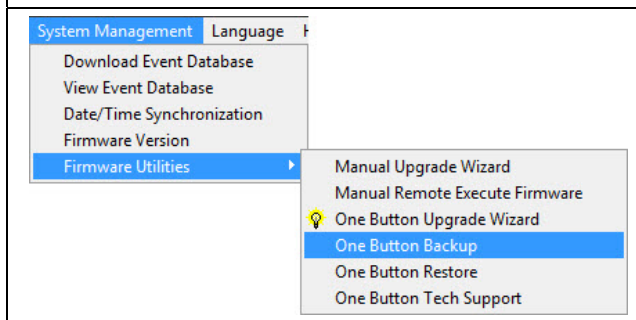

#### 3.11.2 One Button Restore

With this feature (*Figure 28*), the D6200 guides the user through restoring all the user configurations and databases back to the receiver.

**Figure 28: One Button Restore**

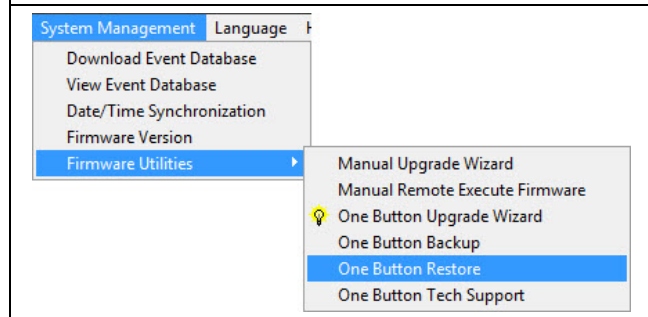

#### 3.11.3 One Button Tech Support

With this feature (*Figure 29*), the D6200 automatically places all the files needed by Bosch Technical Support in one .zip file that can be e-mailed to Bosch Technical Support for troubleshooting.

The only difference between this button and the One Button Backup is that the receiver’s event database is included in the .zip file

When the procedure is completed, the dialog box shows the name and location of the .zip file.

**Figure 29: One Button Tech Support**

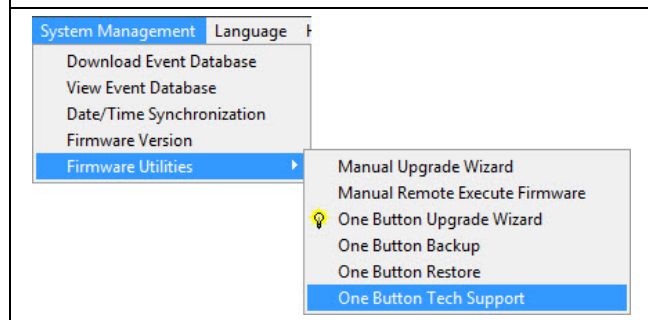

## 3.12 Language and Help Menus

### 3.12.1 Language Menu

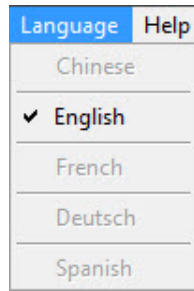

English is the only available language at this time

### 3.12.2 Help Menu

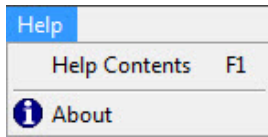



Select **Help Contents** to view the help files for the D6200 Software. Select **About** to view the current D6200 Software revision number (refer to *Figure 30*).

**Figure 30: D6200 About Window**



## 4.0 Upgrading the Software

-  Use the latest D6200 software when upgrading the D6600/D6100IPv6 with the latest firmware.
-  Upgrade the receiver firmware files if they are not the latest revision(s). After the upgrade, verify the correct version number using either the D6200 software or the receiver keypad.

When the system is first started, upgrade the firmware within the D6600/D6100IPv6 through the D6200 Software to ensure that you are using the most recent firmware revision. Future upgrades to the D6600/D6100IPv6 can be performed when they are available.

### 4.1 Performing a One-Button Upgrade

Using this feature (accessible from the D6200 menus or a shortcut icon), the D6200 automatically installs the latest firmware upgrades to the receiver.

Use the Manual Upgrade Wizard to complete the upgrade (refer to Section 4.3 Manual Upgrade Wizard) if the One-Button upgrade procedure is not successful.

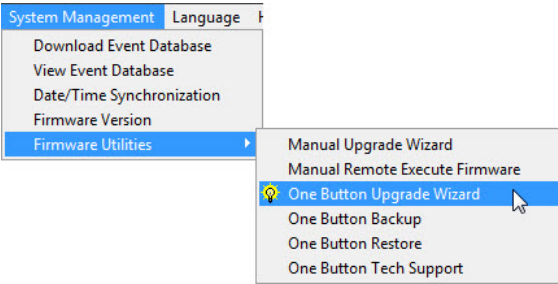
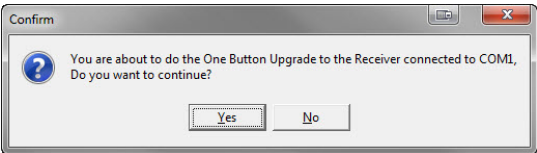
- 
  

- 

Refer to Figure 31.

-  Ensure that the D6600/D6100IPv6 is connected to the automation PC to perform a one-button upgrade so that all events can be acknowledged.

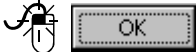
- 

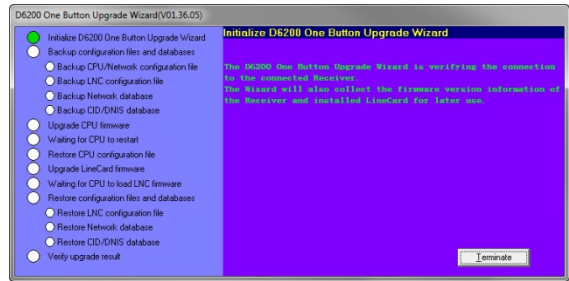

**Figure 31: Acknowledge all pending events before performing One Button Upgrade**

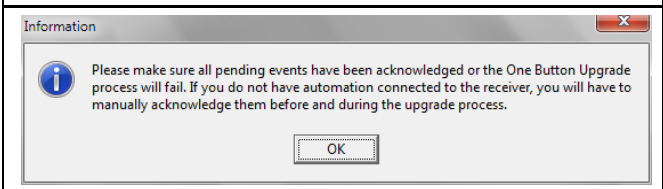

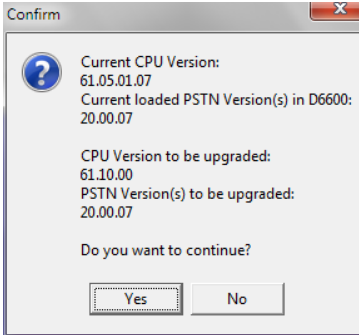
- 

- 

If the receiver is already running the latest CPU version,

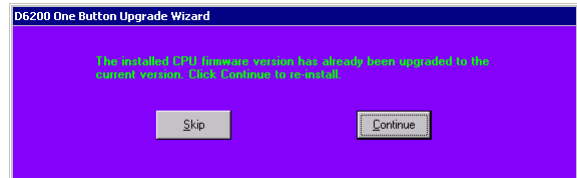

Click **Skip** to not reinstall the CPU or **Continue** to reinstall the CPU.

- 

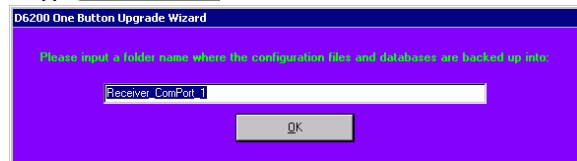

7.

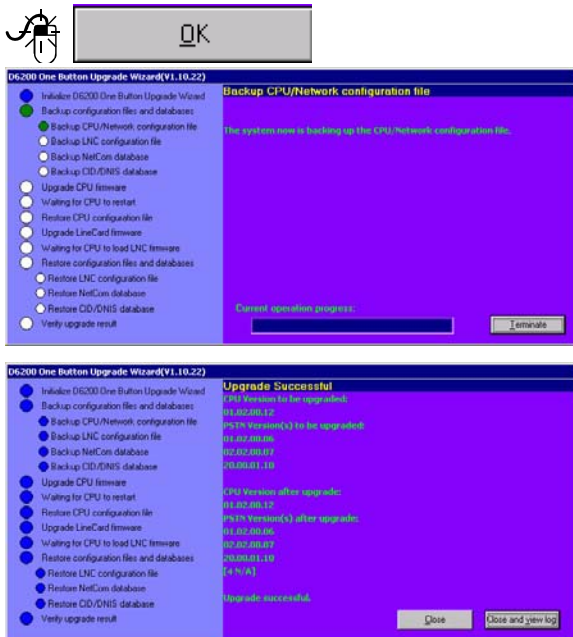

8.



## 4.2 Line Card Firmware Setup (D6600 only)



Starting with v2.00 of the D6200 and CPU v01.10.00, the D6640 is no longer supported. The setup information in this section is for legacy information and operation only.



The D6600 CPU firmware can support up to four different versions of Line Card firmware. Two digital signal processor (DSP) chips control the four lines of each line card [one chip controls each pair of lines (1 and 2 or 3 and 4)]. The D6600 Receiver CPU card can hold up to four versions of line card firmware, but only two versions are available per line card. Select the version you want to run from the Line Card Firmware Setup screen and click the Accept & Program button to cause the line card to run that version of the firmware.

Use the Line Card Firmware Setup in the D6200 Programming Software when the receiver has more than one line-card firmware version loaded into the CPU card. The D6200 Programming Software must be online with the receiver to use this feature. Refer to *Section 3.3 Connection Settings* on page 10.

1.

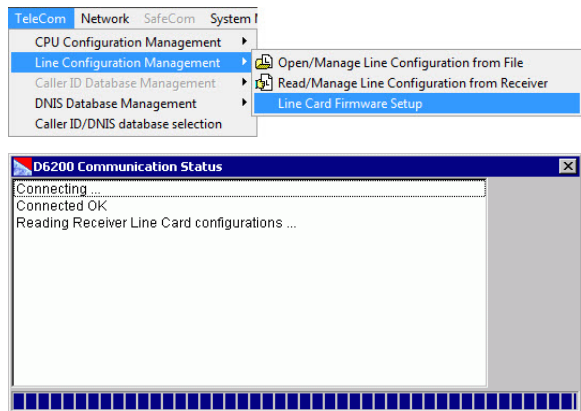

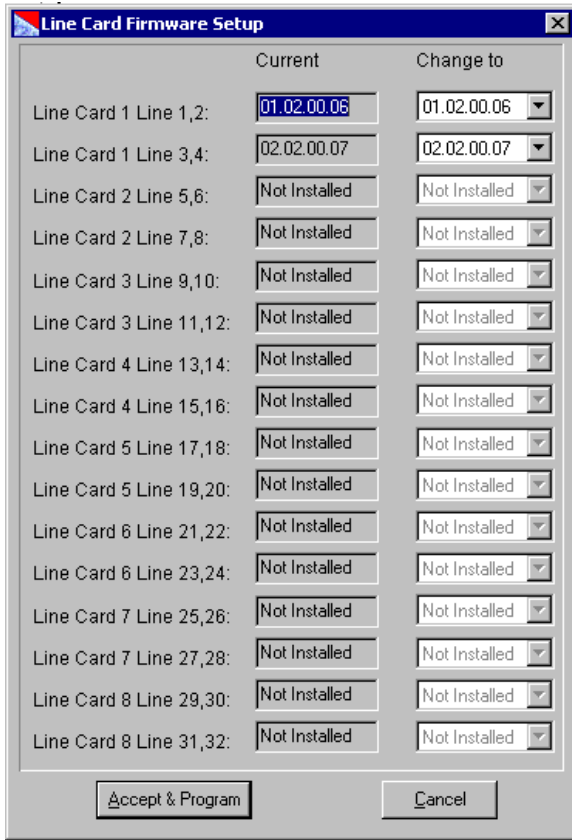

2.

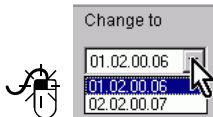

Each line card (controlling two phone lines) can have up to two different firmware versions available for use. The D6600 CPU card can store up to four different versions.

For example, to change the version number of Line Card 1 Line 3,4 from 01.01.04.41 to 02.00.00.44, click the drop down menu and select “02.00.00.44.”

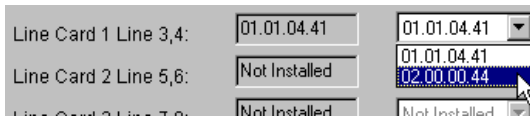

3.

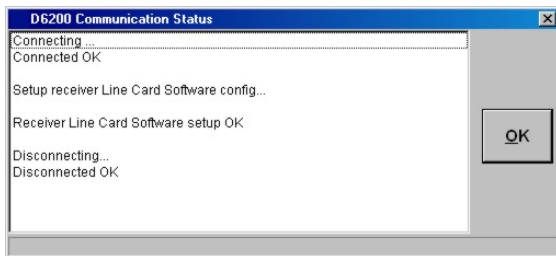

4.

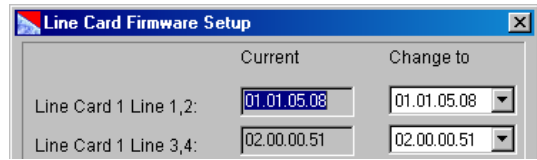
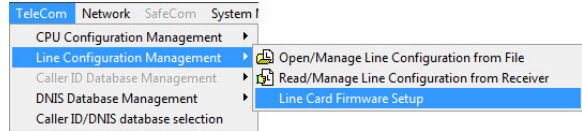

5.

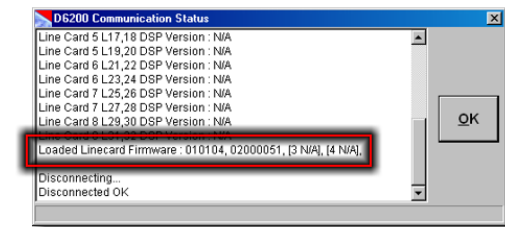
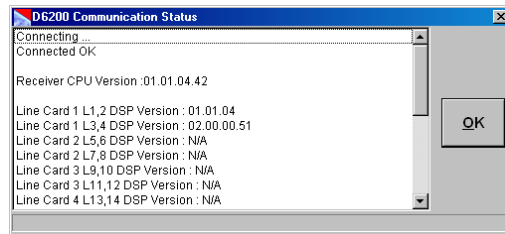
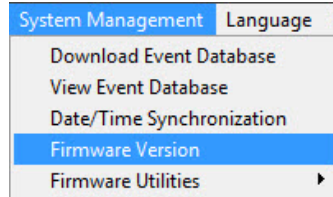

### 4.3 Manual Upgrade Wizard



Bosch Security Systems, Inc. recommends using the One-Button Upgrade. **Sections Error! Reference source not found. to 4.9** are for manual upgrades. Refer to *Section 4.1 Performing a One-Button Upgrade* on page 51 for information about performing a One-Button Upgrade.



All account database configurations are lost when the D6600/D6100IPv6 is rebooted. Save all database configurations that include a network account database (“ACTXX.DB”) and a Caller ID database (“XX.DB”) or DNIS database (“XX.DB”) files with the D6200. Reload these databases into the D6600/D6100IPv6 after the receiver reboots.



Use the latest D6200 software when upgrading the D6600/D6100IPv6 with the latest firmware.

1. Open the software from the CD-ROM.
2. Read the parameter files from the D6600/D6100IPv6.
3. Save the parameter files as XXXX.CPU and XXXX.LNC.
4. Install the new firmware versions.
5. Reload them into the D6600/D6100IPv6.
6. For ITI format support in the D6640, load the PSTN firmware (version 02.xx.xx) into the receiver.
7. Upgrade the newer released versions of CPU and Line Card firmware to the Receiver. An older version of one firmware does not work with a new release of the other.
8. If you are installing or upgrading the D6641, the PSTN firmware must be v20.xx.xx.

#### 4.4 Backing Up the D6600/D6100IPv6 Configuration and Database Files

Receive the different configuration and Database files from the D6600/D6100IPv6 and save them as separate files on the host PC.

##### 4.4.1 CPU/Network Configuration

1. Select **TeleCom → CPU Configuration Management → Read/Manage CPU Configuration from Receiver**.  
A D6200 Communication Status window appears, the D6200 connects to the D6600/D6100IPv6, and the receiver sends the CPU/Network configuration file back to the D6200. After the transfer, the window closes automatically and the CPU/Network Configuration window opens automatically.
2. Click the **Save as** button to open a Save dialog box in the C:\Program Files\D6200 folder on the host PC.
3. Type a new name for the configuration file and end the file name with a .CPU extension.
4. Click **Save**.

##### 4.4.2 Line Configuration

1. Select **TeleCom → Line Configuration Management → Read/Manage Line Configuration from Receiver**.  
A D6200 Communication Status window appears, the D6200 connects to the D6600/D6100IPv6, and the receiver sends the line configuration file back to the D6200. After the transfer, the window closes automatically and the Line Card Configuration window opens automatically.
2. Click the **Save as** button to open a Save dialog box in the C:\Program Files\D6200 folder on the host PC.
3. Type a new name for the configuration file and end the file name with a .LNC extension.
4. Click **Save**.

##### 4.4.3 Caller ID Database (D6600 Only)

1. Select **TeleCom → Caller ID Database Management → Read/Manage Caller ID Database Configuration from Receiver**.  
A D6200 Communication Status window appears, the D6200 connects to the D6600, and the receiver sends the Caller ID database to the D6200. After the transfer, the window closes automatically and the Caller ID Database Management window opens automatically.
2. Click the **Save as** button to open a Save dialog box to the C:\Program Files\D6200 folder on the host PC.
3. Type a new name for the configuration file, beginning the file name with CID and ending with a .DB extension.
4. Click **Save**.

##### 4.4.4 DNIS Database (D6600 Only)

1. Select **TeleCom → Caller ID/DNIS Database**.
2. At the Caller ID/DNIS database selection window, select **Enable DNIS and disable Caller ID** function and click **OK** to close.
3. Select **TeleCom → DNIS Database Management → Read/Manage DNIS Database Configuration from Receiver**.  
A D6200 Communication Status window appears, the D6200 connects to the D6600, and the receiver sends the DNIS database to the D6200. After the transfer, the window closes automatically and the DNIS Database Management window opens automatically.
4. Click the **Save as** button to open a save dialog box to the C:\Program Files\D6200 folder on the Host PC.
5. Type a new name for the configuration file, beginning the file name with DNIS and ending with a .DB extension.

6. Click **Save**.

#### 4.4.5 Network Account Database

1. Select **Network → Network Account Database Management → Read/Manage Network Account Database Configuration from Receiver**.

A D6200 Communication Status window appears, the D6200 connects to the D6600/D6100IPv6, and the receiver sends the network account database to the D6200. After the transfer, the window closes automatically and the Network Account Database Configuration window opens automatically.

2. Click the **Save as** button to open a save dialog box to the C:\Program Files\D6200 folder on the Host PC.
3. Type a new name for the configuration file, beginning the file name with ACT and ending with a .DB extension.
4. Click **Save** to save the file.

#### 4.5 Manually Upgrading the CPU Firmware

Use the One Button Upgrade Wizard to automatically install the latest firmware upgrades to the receiver (refer to *Section 4.1 Performing a One-Button Upgrade*).

In the event that you are installing custom firmware and the One Button Upgrade Wizard cannot be used, choose the Manual Upgrade Wizard.

1. Double-click the Bosch Security Systems icon located in the D6200 Programmer\Firmware CPU-D6610 or CPU-D6110 folder on the CD-ROM.  
The file installs to the necessary location.
2. Open the D6200 Programming Software and select **System Management → Firmware Utilities → Manual Upgrade Wizard** to display active and inactive options. Options are displayed depending on which upgrade, (CPU, Line Card, or System Files) was unzipped.
3. Select the CPU option for loading to the D6600/D6100IPv6 and click **Next**.  
The D6200 guides you through the rest of the installation process.  
The receiver completely loads the CPU code.
4. Select **System Management → Remote Execute Firmware**.



Clear the Event Buffer in the D6600/D6100IPv6 so that the Remote Execute Firmware command can execute. If necessary, press the [ACKNOWLEDGE] button on the front of the receiver to clear the events from the buffer.

#### 4.6 Reloading the Configuration File

##### 4.6.1 CPU Configuration File

1. After the CPU firmware upgrade, the receiver resumes its idle running state (time and date displayed on the LCD or the pending events in the buffer). Reload the CPU configuration file that was saved.
2. Select **TeleCom → CPU Configuration Management → Open/Manage CPU Configuration**.  
The Open Receiver CPU/Network Configuration file dialog box appears and points to the C:\Program Files\D6200 folder on the Host PC.
3. Select the file name of the recently saved CPU/Network configuration file and click **Open**.  
The CPU configuration window opens.
4. Click the **Send to Receiver** button to send the file to the receiver.  
A D6200 communication status window appears, connects to the receiver, and the D6200 sends the saved CPU/Network configuration file to the receiver.
5. When the transfer is complete, click **OK** to close the window.
6. To verify that the CPU firmware upgrade occurred, use the D6200 Programming Software to select System Management Firmware Version. CPU vxx.xx.xx appears.

##### 4.6.2 Line Configuration File

1. Select **TeleCom → Line Configuration Management → Open/Manage Line Configuration**.  
The Open Receiver Line Configuration file dialog box appears and points to the C:\Program Files\D6200 folder on the host PC.
2. Select the file name of the recently saved line configuration file and click **Open**.  
The Line configuration window opens.
3. Click the **Send to Receiver** button to send the file to the receiver.  
A D6200 communication status window appears, connects to the receiver, and the D6200 sends the saved Line configuration file to the receiver.
4. When the transfer is complete, click **OK** to close the window.

#### 4.6.3 Caller ID Database Configuration File (D6600 Only)

1. Select **TeleCom → Caller ID Database Management → Open/Manage Caller ID Database Configuration**.  
The Open Receiver Caller ID Database Configuration file dialog box appears and points to the C:\Program Files\D6200 folder on the host PC.
2. Select the file name of the recently saved Caller ID Database configuration file and click **Open**.  
The Caller ID Database configuration window opens.
3. Click the **Send to Receiver** button to send the file to the receiver.  
A D6200 communication status window appears, connects to the receiver, and the saved Caller ID Database configuration file is sent to the receiver.
4. When the transfer is complete, click **OK** to close the window.

#### 4.6.4 DNIS Database Configuration File (D6600 Only)

1. Select **TeleCom → DNIS Database Management → Open/Manage DNIS Database Configuration**.  
At the Open Receiver DNIS Database Configuration file dialog box appears and points to the C:\Program Files\D6200 folder on the Host PC.
2. Select the file name of the recently saved DNIS Database configuration file and click **Open**.  
The DNIS Database configuration window opens.
3. Click the **Send to Receiver** button to send the file to the receiver.  
A D6200 communication status window appears, connects to the receiver, and the D6200 sends the saved DNIS Database configuration file to the receiver.
4. When the transfer is complete, click **OK** to close the window.

#### 4.6.5 Network Account Database Configuration File

1. Select **Network → Network Account Database Management → Open/Manage Network Account Database Configuration**.  
The Open Receiver Network Account Database Configuration file dialog box appears and points to the C:\Program Files\D6200 folder on the host PC.
2. Select the file name of the recently saved Network Account Database configuration file and click **Open**.  
The Network Account Database configuration window opens.

3. Click the **Send to Receiver** button to send the file to the receiver.  
A D6200 communication status window appears, connects to the receiver, and the D6200 sends the saved Network Account Database configuration file to the receiver.
4. When the transfer is complete, click **OK** to close the window.

#### 4.7 Upgrading the D6640 Line Card Firmware (v01.xx.xx)



Starting with v2.00 of the D6200 and CPU v01.10.00, the D6640 is no longer supported. The setup information in this section is for legacy information and operation only.

1. After the CPU firmware successfully loads, load the Line Card Firmware.
2. To upgrade the D6640 Line Card Firmware, double click the Bosch Security Systems icon located in the D6200 Programmer\Firmware\PSTN-D6640\_v01 folder on the CD-ROM.  
The file installs in the necessary location.
3. Open the D6200 Programming Software and select **System Management → Firmware Upgrade Wizard** to display active and inactive options. Options appear, depending on which file (CPU, Line Card, or System Files) was unzipped.
4. Check the Line Card option to be loaded to the D6600 and click **Next**.  
The D6200 guides you through the rest of the installation process (approximately two min to load the receiver with the new Line Card Firmware).
5. After the Line Card upgrade, verify that the Line Card Firmware upgrade occurred.
6. Using the D6200 Programming Software, select **System Management Firmware Version**.  
PSTN v01.xx.xx appears.



After the firmware loads and updates to the installed release, the line cards reset.

#### 4.8 Upgrading the D6640 Line Card Firmware (v02.xx.xx)



Starting with v2.00 of the D6200 and CPU v01.10.00, the D6640 is no longer supported. The setup information in this section is for legacy information and operation only.

1. Load the D6640 PSTN firmware (v02.xx.xx) into the receiver to support the ITI format.



2. To upgrade the line card firmware, double click the Bosch Security Systems icon located in the D6200 Programmer\Firmware\PSTN-D6640\_v02 folder on the CD-ROM  
The file installs in the necessary location.
3. Open the D6200 Programming Software, and select **System Management → Firmware Upgrade Wizard** to display active and inactive options. Options are displayed, depending on which upgrade (CPU, Line Card, or System Files) is unzipped.
4. Check the Line Card option to load to the D6600 and click **Next**.  
The D6200 guides you through the rest of the installation process (approximately two min to load the receiver with the new line card firmware).
5. After the line card upgrade, verify that the line card firmware upgrade took effect. Use the D6200 Programming Software to select **System Management Firmware Version**.  
PSTN v02.xx.xx appears.



After the firmware loads and updates to the installed release, the line cards reset.

#### 4.9 Upgrading the D6x41 Line Card Firmware

1. Load the D6x41 PSTN firmware into the receiver.
2. To upgrade the line card firmware, double click the Bosch Security Systems icon located in the D6200 Programmer\Firmware\PSTN-D6x41\_ folder on the D6600/D6100IPv6 CD-ROM  
The file installs in the necessary location.
3. Open the D6200 Programming Software and select **System Management → Firmware Upgrade Wizard** to display active and inactive options. Options are displayed, depending on which upgrade (CPU, Line Card, or System Files) is unzipped.
4. Check the Line Card option to load to the D6600 and click **Next**.
5. The D6200 guides you through the rest of the installation process (approximately two min to load the receiver with the new line card firmware).
6. After the line card upgrade, verify that the line card firmware upgrade took effect. Use the D6200 Programming Software, to select **System Management Firmware Version**.  
PSTN v20.xx.xx appears.



After the firmware loads and updates to the installed release, the line cards reset.

#### 4.10 Upgrading the D6600 System Files

1. If the CPU firmware was upgraded from v01.01.01 or earlier, install the System Files to the D6600.
2. To upgrade the System Files firmware, double-click the Bosch Security Systems icon located in the D6200 Programmer\Firmware\System Files folder on the CD-ROM.  
The file unzips and installs in the necessary location.
3. Open the D6200 Programming Software, and select **System Management → Firmware Upgrade Wizard** to display active and inactive options. Options are displayed, depending on which upgrade (CPU, Line Card, or System Files) was unzipped.
4. Check the System File option to be loaded to the D6600 and click **Next** (approximately ten sec to load the receiver with the new System Files firmware).  
The D6200 guides you through the rest of the installation process.



Turn the D6600 off and then on for the system files to take effect. The receiver is fully operational after it is on for approximately three min.

The firmware upgrade is now complete.

## 5.0 Troubleshooting

### 5.1 Uninstalling the D6200 Software

1.

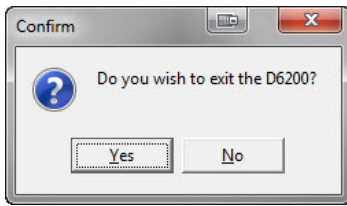
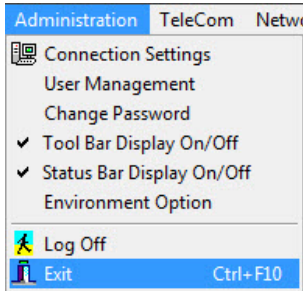

2.



3.

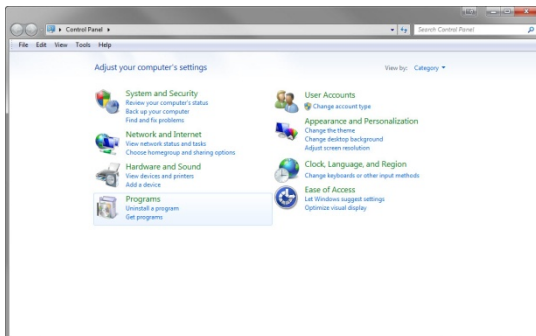
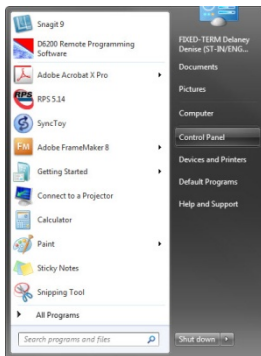

4.

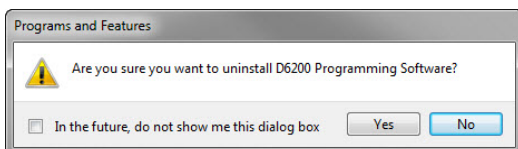

5.



### 5.2 Assigning IP Addresses Using Telnet



For the D6686 and D6100IPv6, they will use the XML Configuration tab for setup. For the details of programming a D6686 or D6100IPv6 using the XML tab, please refer to the Installation and Operation manuals for those products.

*D6686 Installation Guide (P/N: F01U269888)*

*D6600/D6100IPv6 IOG (P/N: 4998122704)*



The IP and MAC addresses shown here are for demonstration only.

#### 5.2.1 Initial Assignment of the IP Address Using ARP

Read this entire section before beginning. Ensure that power is applied to the network device (C900TTL-E, D9133TTL-E, C900V2, DX4020, D6680, D6682 or D6100i) and the Ethernet Network RJ45 connections are in place.



To connect to the network device (C900TTL-E, D9133TTL-E, C900V2, DX4020, D6680, D6682 or D6100i) using telnet, ensure that the network device and the PC that is configuring it are on the same gateway (the device that connects the LAN to the WAN).

After the network device is configured and has an IP address, you can make changes by opening a telnet session from anywhere on the network.

Use the ARP program to assign a new IP address for the network device (C900TTL-E, D9133TTL-E, C900V2, DX4020, D6680, D6682 or D6100i) when you have the IP address and the network administrator confirms that the device is ready.

The Address Resolution Protocol (ARP) program creates a temporary association between an IP address and a hardware address, such as a MAC. By default, the ARP program is installed into the C:\WINDOWS directory during the operating system's installation.

Use the command as shown in *Figure 32* at the MS-DOS prompt.

**Figure 32: ARP Command Usage**

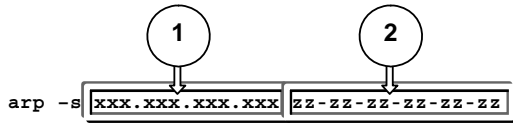

- 1 - xxx.xxx.xxx.xxx - The IP address assigned to the network device (C900TTL-E, D9133TTL-E, C900V2, DX4020, D6680, D6682 or D6100i) by the Network Administrator.
- 2 - zz-zz-zz-zz-zz-zz - The MAC hardware address found on the label of the network device (C900TTL-E, D9133TTL-E, C900V2, DX4020, D6680, D6682 or D6100i).

**ARP Command Usage**

1.

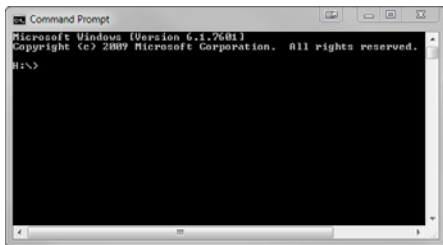
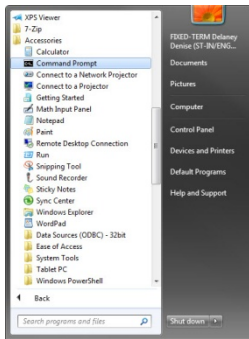

2. Type `arp -s xxx.xxx.xxx.xxx yy-yy-yy-yy-yy-yy` (xxx.xxx.xxx.xxx is the IP address of the network device and yy-yy-yy-yy-yy-yy is the MAC hardware address).

3.



`c:\>` IP address and MAC address accepted.

No error messages indicate that the ARP command was successful.

4. Type `arp -g`.

5.

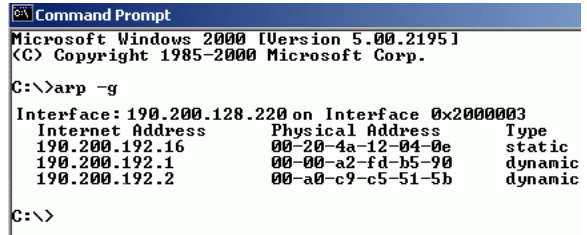

**5.2.2 Using Telnet to Complete the IP Address Configuration**



In Windows Vista, Telnet is disabled by default. In order to use Telnet, you must enable it:

1. Click **Start**→**Control Panel**→**Programs**.
2. Click **Turn Windows features on or off**.  
If you are prompted for an administrator password or confirmation, type the password or provide confirmation.
3. In the **Windows Features** dialog box, select the **Telnet Client** check box.

Click **OK**.  
The installation might take several minutes.



To use Telnet, you must log in as a user with Administrative privileges.



This example uses the IP address of 172.17.10.70 and the MAC Address of 00-20-4a-72-04-0e. Your IP and MAC address will differ.

1.

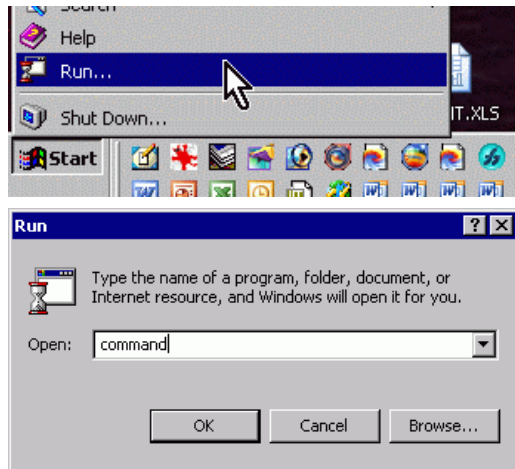



```

Command Prompt
Microsoft Windows 2000 [Version 5.00.2195]
(C) Copyright 1985-2000 Microsoft Corp.

C:\>_
    
```

 The colors are inverted here for clarity. The normal prompt window appears with white text on black.



```

Command Prompt
Microsoft Windows 2000 [Version 5.00.2195]
(C) Copyright 1985-2000 Microsoft Corp.

C:\>telnet
    
```

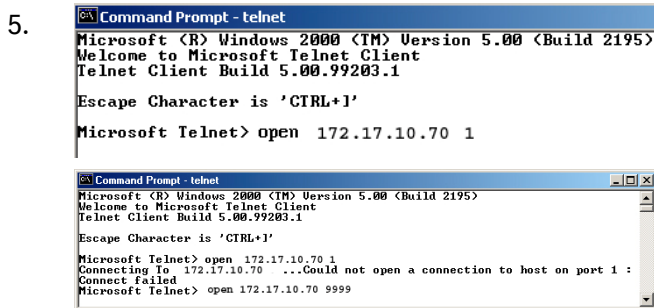

 Pressing [F3] displays the last line typed. Backspace over the port number (1) and change to 9999.



```

Command Prompt - telnet
Lantronix UTS Snr 1281-167 U3.6

Press Enter to go into Setup Mode

*** basic parameters
Hardware: Ethernet Autodetect
IP addr 010.025.124.148, no gateway set,netmask 255.255.000.000

***** Channel 1 *****
Baudrate 09600, I/F Mode 4C, Flow 00
Port 03001
Remote IP Adr: 010.025.124.146, Port 03000
Connect Mode: C0 Disconn Mode: 01
Flush Mode: 00

Change Setup : 0 Server configuration
                1 Channel 1 configuration
                7 factory defaults
                8 exit without save
                9 save and exit                Your choice ?
    
```

7. To complete the procedure, refer to the appropriate installation guide:

- *C900TTL-E Installation Guide* (P/N: 4998122718)
- *D9133TTL-E Installation Guide* (P/N: 4998122717)
- *C900V2 Installation Guide* (P/N: F01U003472)
- *DX4020 Installation Guide* (P/N: F01U045288)
- *D6680 Network Adapter Installation Guide* (P/N: 4998138732)
- *Conettix D6682 Ethernet Network Adapter Installation Guide* (P/N: F01U078049)

### 5.3 Using the Ping Utility

The PING.EXE utility determines whether a specific IP address is accessible by sending a packet of data to the specified address and waiting for a reply. Troubleshooting network connections and verifying network connections for the network devices are the primary uses for the ping utility.

 PING.EXE is normally installed along with the networking component in Windows 2000, XP, and Vista. It is not installed if you have not yet installed any networking components. PING.EXE can be extracted from the Windows Installation .CAB (cabinet) files.

 Record the IP address. You must know the IP address of the device you are attempting to verify.

 This example uses the IP address of 10.25.124.148. Your IP address is different.

1. 

2.  **[ENTER]**

If your machine is not configured properly, it might appear to do nothing. This also indicates that the PING command failed. You can usually terminate the PING command with the **[Ctrl] + [C]** key combination (press and hold the **[Ctrl]** and press **[C]** once).

If successful,

```

C:\>ping 10.25.124.148
Pinging 10.25.124.148 with 32 bytes of data:
Reply from 10.25.124.148: bytes=32 time<10ms TTL=128
Reply from 10.25.124.148: bytes=32 time<10ms TTL=128
Reply from 10.25.124.148: bytes=32 time<10ms TTL=128
Reply from 10.25.124.148: bytes=32 time<10ms TTL=128

Ping statistics for 10.25.124.148:
    Packets: Sent = 4, Received = 4, Lost = 0 (0% loss),
    Approximate round trip times in milli-seconds:
        Minimum = 0ms, Maximum = 0ms, Average = 0ms

C:\>
    
```

If unsuccessful,

```

C:\>ping 10.25.124.148
Pinging 10.25.124.148 with 32 bytes of data:
Request timed out.
Request timed out.
Request timed out.
Request timed out.

Ping statistics for 10.25.124.148:
    Packets: Sent = 4, Received = 0, Lost = 4 (100% loss),
    Approximate round trip times in milli-seconds:
        Minimum = 0ms, Maximum = 0ms, Average = 0ms

C:\>
    
```

## 6.0 Specifications

**Table 4: D6200 Specifications**

System PC Requirements			
	Multimedia	CD-ROM	20x to 48x
		Hard Disk	500 MB of available space
	Communication Requirements	Network Card	Windows supported (required only if communicating D6600)
		Ports	One serial port Additional serial, parallel, or USB ports might be required based on configuration.
	Operating System	Microsoft Windows XP, Vista, Windows 7, or Windows 8	
	Processor	CPU: 1 GHz or higher	
RAM	<b>Windows XP:</b> at least 512 MB <b>Windows Vista:</b> at least 1024 MB <b>Windows 7:</b> at least 1024 MB <b>Windows 8:</b> at least 1024 MB		
D6200 Software Specification	Compatible Receivers	D6600, D6100i, D6100IPV6	
	Automation Modes	6500, SIA	

## End User Software License Agreement

Bosch Security Systems, Inc. ("Bosch") licenses this software and all associated documentation (the "Software") for your (also referred to herein as "Licensee") non-exclusive use. Licensee has read this End User Software License Agreement ("License") and agrees to abide by the terms and conditions of this License. By using the Software you the Licensee accept and agree that you will abide by and are legally bound by the terms of this License. If you do not agree to abide by the terms of this License you shall immediately return the Software to Bosch. Licensee's use of the Software is subject to the following terms and conditions:

1. **LICENSE** - Under the terms of this nonexclusive, non-transferable (except as specifically permitted herein) license:
  - 1.1 You may use a machine-readable form of the Software on a single computer or a single server at a time, or as otherwise defined in the installation/operation manual of the Bosch product and only for the operation of Bosch products.
  - 1.2 You may not modify, translate, create derivative works, decompile, disassemble or reverse engineer the Software.
  - 1.3 You may not sublicense, lease or otherwise rent the Software without Bosch's prior written consent.
  - 1.4 You may make one copy of the Software solely for backup or archival purposes, provided such copy must contain the original Software proprietary notice. No other copying of the Software or the accompanying documentation is permitted.
  - 1.5 This License will terminate automatically if you fail at any time to comply with any of its terms or conditions. Upon termination, you shall immediately destroy the Software or return it to Bosch along with any copies you have made, and to delete any installed copy from your hardware.
2. **TRANSFER OF OWNERSHIP** - You may transfer this License to another party only if you:
  - 2.1 Also transfer the License, Software, and all accompanying documentation and (by sale or lease) ownership of the associated Bosch hardware, if applicable,
  - 2.2 Require the other party to abide by the terms of this License, and
  - 2.3 Destroy all copies of the Software and any updates that you do not transfer to the other party.
3. **OWNERSHIP AND PROPRIETY RIGHTS** - Although the diskette/media containing the Software is yours, the Software is owned and copyrighted by Bosch and/or its suppliers. Except for the rights expressly granted herein, Bosch and its suppliers retain all rights to the Software, including, without limitation, the title to all copyright, patent, trade secret and other intellectual and proprietary rights therein and any copies thereof, in whole or in part, all of which are the valuable property of Bosch and/or its suppliers. You may not remove, change or delete the copyright notice from the Software. If you make any copies of the Software in whole or in part, all such copies shall contain the same copyright and proprietary markings as appear on or in the original Software copy, including diskette markings. You will instruct your employees and others having access to the Software in and ensure their compliance with the terms of this License. You will use your best efforts to prevent any unauthorized copying of the Software. You will be responsible for any breach of any provision of this License by your employees. You shall not sell, transfer, publish, disclose or otherwise make available the whole or any part of the Software or any copies thereof to any third party or persons not permitted by the terms of, and pursuant to the terms contained in this License. You are not in violation of this Agreement, including this section, when a third party views the functional output resulting from your use of the Software.
4. **TAXES** - You must pay all taxes that may now or hereafter be imposed, levied, or assessed with respect to the possession or use of the Software or this License. You shall file all reports required in connection with such taxes.
5. **WARRANTY, LIMITATION OF LIABILITY, REMEDIES** - THE SOFTWARE IS PROVIDED "AS IS" WITHOUT WARRANTY OF ANY KIND INCLUDING WARRANTIES THAT THE SOFTWARE IS ERROR FREE OR WILL RUN UNINTERRUPTED, OR WARRANTIES OF MERCHANTABILITY, FITNESS FOR A PARTICULAR PURPOSE OR AGAINST INFRINGEMENT. NEITHER BOSCH NOR ITS SUPPLIERS SHALL BE LIABLE FOR ANY LOSS OF PROFITS, LOSS OF USE, INTERRUPTION OF BUSINESS, LOSS OF DATA, NOR FOR INDIRECT, SPECIAL, INCIDENTAL, OR CONSEQUENTIAL DAMAGES OF ANY KIND WHETHER UNDER THIS LICENSE OR OTHERWISE, OR FOR ANY CLAIM BY ANY OTHER PARTY. Bosch does not warrant the functions provided by the Software. However, Bosch warrants the diskette or other media on which the Software is furnished to be free from material defects in materials and workmanship under normal use for a period of 90 days from the date of original purchase. Bosch's entire liability to you, and your exclusive remedy, shall be the replacement of the diskette or other media not meeting Bosch's warranty, provided you return the same to Bosch. The replacement will be warranted for the remainder of the term of the original warranty or 30 days, whichever is longer. You assume responsibility for the selection of the Software to achieve your intended results, and for the installation, use and results obtained from the Software. Without limiting the generality of the foregoing, in no event shall Bosch be liable for any consequential, special or general damages in any action, whether based on tort, contract or otherwise, in connection with this License, or the Software furnished hereunder. The damages excluded under this paragraph include, but are not limited to, damages for loss of actual and anticipated profits, loss of programming and/or production materials, and damage to the business reputation of user.
6. **U.S. GOVERNMENT RESTRICTED RIGHTS** - The Software is provided with restricted rights. Use, duplication, or disclosure by the U.S. Government is subject to restrictions as set forth in subparagraph (c)(1)(ii) of the Rights in Technical Data and Computer Software clause at DFAR 252.227-7013, Federal Acquisition Regulation clause 52.227-19 (c) (2) Commercial Computer Software Restricted Rights, NASA clause 52.227.86 (d) Commercial Computer Software Licensing or their successor.

7. EXPORT LAWS, APPLICABLE LAW - If you, the licensee under this License, are not a U.S. citizen or you will take delivery of the Software outside the United States, Bosch will secure the necessary U.S. Government authorizations for exportation of the Software to your country of destination. You agree to not reexport the Software from that destination to another foreign country without complying with all applicable U.S. Government restrictions and requirements. If you, the licensee, are a U.S. citizen or you will take delivery of the Software inside the United States, then you agree to not export the Software from the United States without complying with all applicable U.S. Government restrictions and requirements, including obtaining any necessary U.S. Government authorization for the export. You will not permit the Software to be reexported from an authorized foreign destination country to any other foreign country except in compliance with all U.S. laws and regulations. This License will be governed by the laws of the State of New York and the United States of America, including U.S. copyright laws.

8. TERM AND TRANSFER You may terminate this Agreement at any time by returning the Software to Bosch or destroying the Software together with all copies in any form. Bosch may terminate this Agreement if you fail to comply with its terms and conditions in any material respect. Upon termination, you may not use the Software and must return or destroy all copies thereof in whole or in part, and we will not further support the Software.

9. ENTIRE CONTRACT - This License, including all schedules, constitutes the entire and only agreement between the parties and supersedes all prior agreements, understandings and communications, whether oral or written, between the parties respecting the subject matter hereof. There are no understandings, agreements, warranties or representations, express or implied, except as set forth herein. This License prevails over any additional, conflicting or inconsistent terms and conditions appearing on any purchase order submitted by Licensee. This License shall be governed by and interpreted under the laws of New York, excepting any conflicts of laws provision. Jurisdiction for any suit brought hereunder shall be the federal or state courts residing in New York City

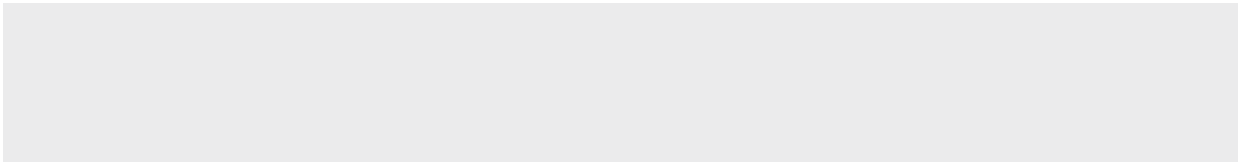

**Bosch Security Systems, Inc.**  
130 Perinton Parkway  
Fairport, NY 14450  
USA  
[www.boschsecurity.com](http://www.boschsecurity.com)

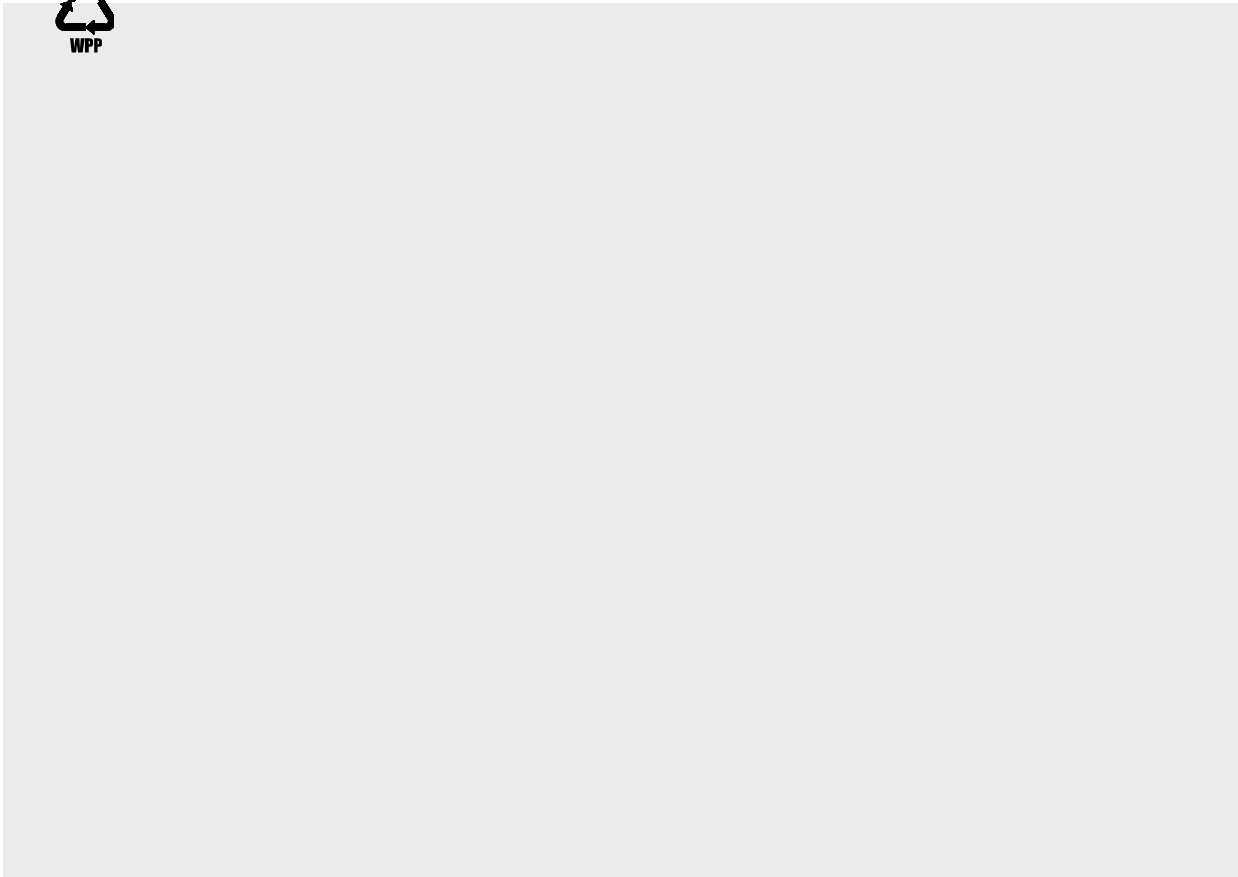

**BOSCH**