

KRYPTO
HIGH SECURITY SOLUTION

K1BT
*KRYPTO Bluetooth
High-Security Card Reader*

CDVI's KRYPTO K1BT card reader facilitates high security!

The K1BT KRYPTO bluetooth reader is compatible with the ATRIUM BT mobile application and the KRYPTO Mobile-PASS.

The K1BT works with the secure protocol of CDVI, the encryption keys guarantee end-to-end encryption between the credential, the reader and the A22K door controller.

KRYPTO K1BT - High security made easy!



FC Certification

CE Certification

⊖ -25°C to +60°C

IP IP53

⌘ DEEE

RoHS

Bluetooth™



OSDP™

- Works with ATRIUM A22K controller
- Compatible with ATRIUM BT application and KRYPTO Mobile-PASS (Bluetooth)
- FULLY secure RS-485 connection (4 wires)
- Reads KRYPTO Mobile-PASS, 13.56 MHz Mifare Classic and DESFire EV1/EV2 credentials
- OSDP-2 compatible
- Up to 2" (5 cm) read range
- Power requirements: 12 VDC
- Current consumption : 200mA

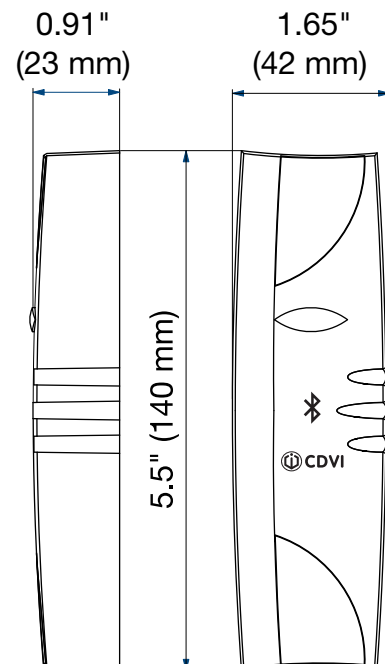

WIRING DIAGRAM

A22K CONTROLLER

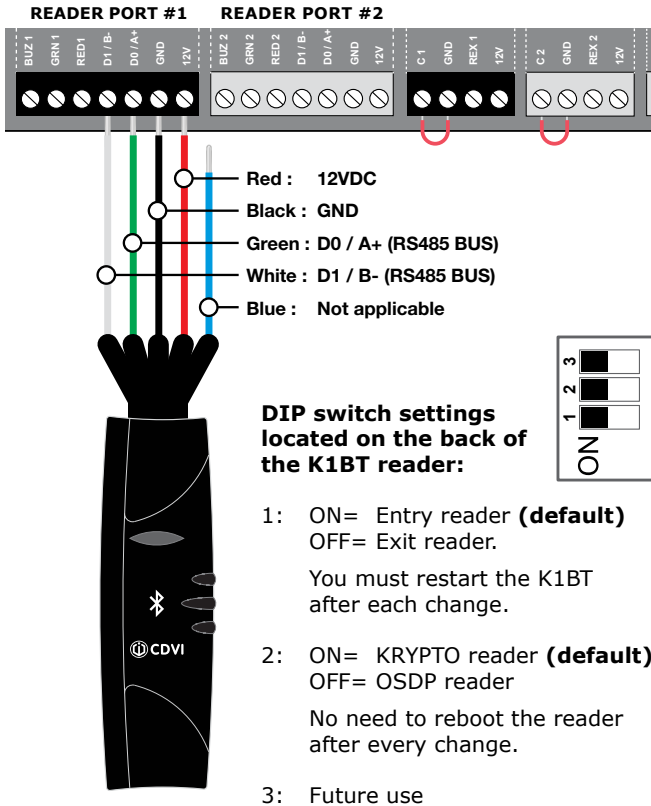

It is recommended to use twisted pair wiring as shown below between the reader and the ATRIUM A22K controller.

Furthest reader can be installed up to 4,000 ft (1220 m) from the A22K controller (AWG 22 cable).



CABLE CONNECTIONS

Wire Leads	Connect to A22K Reader Port
Red	12 VDC
Black	GND
Green	D0 / A+
White	D1 / B-

LED STATUS INDICATORS

Here are the LED statuses when connected to an ATRIUM A22K controller:

LED State	Buzzer	Description
Steady blue	-	Standby (door secure)
Turn green for 5 sec.	Chirp beep	Access granted
5 rapid red blinks	Steady beep for 3 sec.	Access denied
Flashing blue	-	Reader compromised (lost its encryption key)
Blinks green every 3 sec.	-	Door unlock schedule
Flashing red	Steady beep	Door forced alarm
Flashing red	Beep every 2 sec.	Door open too long pre-alarm
Flashing red rapidly	Fast beep	Door open too long alarm

Note: Door output timings such as; unlock time (access granted), door open too long pre-alarm and door open too long alarm, can be modified in the ATRIUM software "Door Properties" window.

Note: Each ATRIUM A22K controller support 2 reader connected in parallel per port (ENTRY and EXIT readers).

Offset the readers by a minimum of 6 inches to avoid interference.

MOUNTING

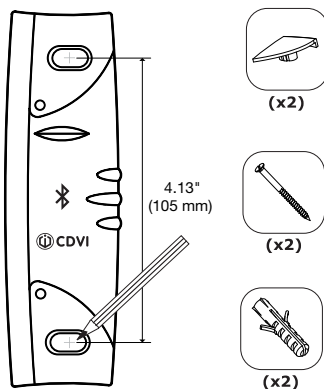

- Connect wires as shown above in "Wiring Diagram".
- Once leveled and aligned, mark the mounting holes of the reader.
- Drill the fixing screw holes. Use provided anchors if required.
- Once the card reader is mounted to the wall, place the screw cover caps on the reader.