

Omega 4K/UHD Scaler for HDBaseT and HDMI

AT-OME-RX31



The Atлона **AT-OME-RX31** is an HDBaseT receiver, three-input switcher, and 4K/UHD scaler with a local HDMI input. Part of the Omega™ Series of integration products for modern AV communications and collaboration, the OME-RX31 features two HDBaseT inputs for receiving video up to 4K/60 4:2:0, plus embedded audio, control, Ethernet, and USB over distances up to 330 feet (100 meters). The HDMI input supports video up to UHD/60 4:4:4. The OME-RX31 is HDCP 2.2 compliant and features 4K/60 upscaling and downscaling with frame rate conversion. Additionally, it provides integrated control for displays and room functions such as motorized screens, and can be externally triggered with the addition of an occupancy sensor. The OME-RX31 is ideal for 4K presentation applications with Omega, HDVS-200, or UHD-EX Series transmitters, as well as Atлона AV presentation switchers with HDBaseT outputs, local HDMI sources, and the Gain™ Series amplifiers.

Package Contents

- 1 x AT-OME-RX31
- 2 x Mounting brackets
- 4 x Mounting screws
- 2 x 5-pin captive screw connector
- 1 x 4-pin captive screw connector
- 1 x 3-pin captive screw connector
- 1 x 24 V DC power supply
- 1 x Installation Guide



IMPORTANT: Visit <http://www.atlona.com/product/AT-OME-RX31> for the latest firmware updates and documentation.

Panel Descriptions

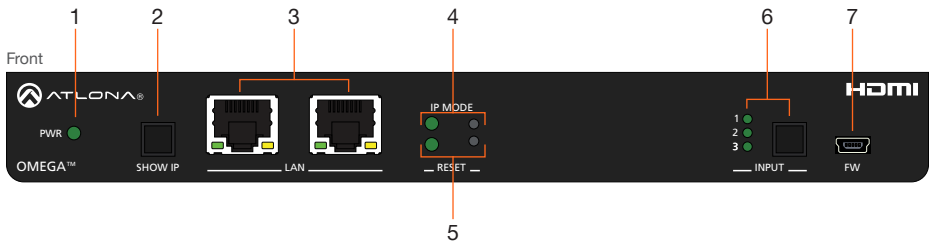

- 1 PWR**
This LED indicator glows solid green when the unit is powered.
- 2 SHOW IP**
Press and release this button to display the IP address of the AT-OME-RX31 on the connected display.
- 3 LAN**
Connect Ethernet cables to these ports to control the unit and/or to pass Ethernet to a local device.
- 4 IP MODE**
Press and release this button, next to the green LED indicator, to switch the IP mode between DHCP and static IP modes. The LED indicator will provide the current IP mode. Refer to [IP Configuration \(page 10\)](#) for more information.
- 5 RESET**
Press and release this button to reset the unit to factory-default settings. Refer to [Resetting to Factory-Defaults \(page 11\)](#) for more information.
- 6 INPUT**
Press and release this button to cycle through each of the three inputs. A solid green LED indicator will display the currently active input. Each LED indicator corresponds to each of the numbered inputs on the rear panel of the unit.
- 7 FW**
Connect a USB to mini-USB cable from this port to a computer to updated the firmware. Refer to the User Manual for more information.

Panel Descriptions

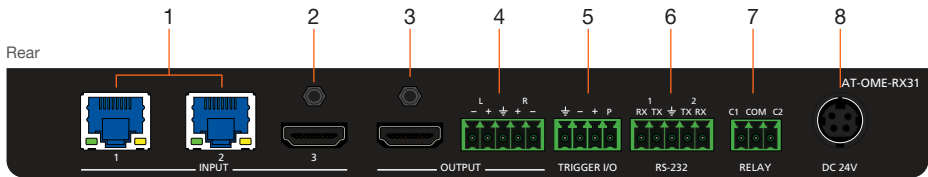

- 1 INPUT (HDBaseT)**
 Connect up to two category cables (CAT-5e or better) from each of these ports to a compatible HDBaseT transmitter.
- 2 INPUT (HDMI)**
 Connect an HDMI cable from this port to a UHD/HD source.
- 3 OUTPUT (HDMI)**
 Connect an HDMI cable from this port to a display device.
- 4 OUTPUT (AUDIO)**
 Connect an audio output device to this port using the included 5-pin captive screw block. Refer to [Audio Output Connector \(page 4\)](#) for wiring information.
- 5 TRIGGER I/O**
 Connect voltage-controlled device to this port. A 4-pin captive screw connector is required. Refer to [TRIGGER I/O Connector \(page 5\)](#) for wiring information.
- 6 RS-232**
 Connect the included 5-pin captive screw to this port to provide RS-232 control for the AT-OME-RX31 and the connected display. Refer to [RS-232 Connector \(page 6\)](#) for wiring information.
- 7 RELAY**
 Connect the included 3-pin captive screw block to this port. This port provides a port, which allows the control of screens, curtains, and other devices. Use a 48 V DC relay with no more than 1 A current draw. Refer to [RELAY Connector \(page 7\)](#) for wiring information.
- 8 DC 24V**
 Connect the included 24 V DC power supply to this power receptacle.

Audio Output Connector

The AT-OME-RX31 provides two-channel LPCM audio de-embedding of the source device, using a dedicated audio output port.

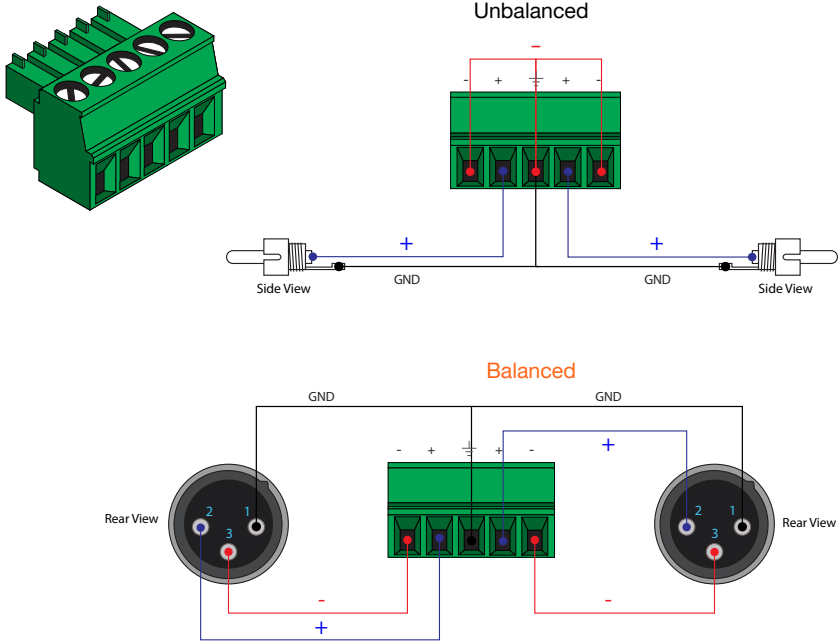

1. Use wire strippers to remove a portion of the cable jacket.
2. Remove at least 3/16" (5 mm) of insulation from each of the wires.
3. Insert the wires into the correct terminals using the included 5-pin captive screw connector.
4. Attach the 5-pin connector block to the **OUTPUT** audio port on the AT-OME-RX31.

TRIGGER I/O Connector

The **TRIGGER I/O** port allows voltage-controlled devices, such as an occupancy sensor, to be connected to the AT-OME-RX31. Use the included 4-pin captive screw connector to connect the device. The voltage range is 3 V to 30 V DC.

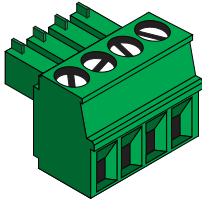

Powered Sensor

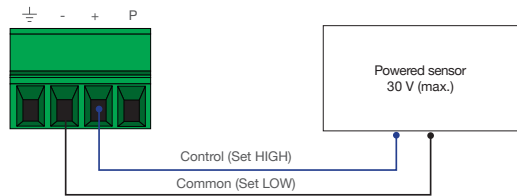

Passive Sensor

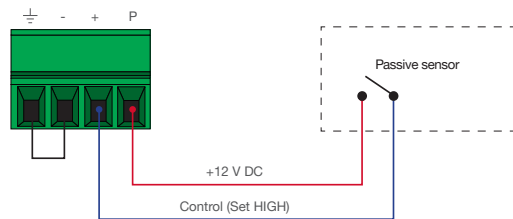

1. Use wire strippers to remove a portion of the cable jacket.
2. Remove at least 3/16" (5 mm) of insulation from each of the wires.
3. Insert the wires into correct terminal using the included 4-pin captive screw connector.
4. Attach the 4-pin connector block to the **TRIGGER I/O** port on the AT-OME-RX31.

RS-232 Connector

The AT-OME-RX31 provides an **RS-232** port for RS-232 control. **RS-232 1** is used for controlling the connected display. **RS-232 2** is used for controlling the AT-OME-RX31. Note that the ground pin is shared between port 1 and port 2.

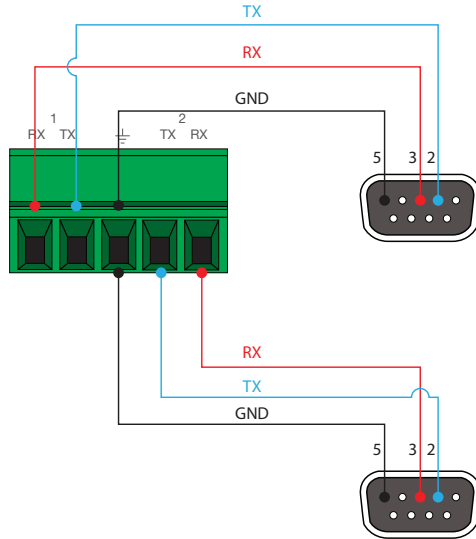
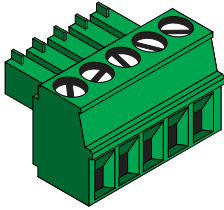

NOTE: Typical DB9 connectors use pin 2 for TX, pin 3 for RX, and pin 5 for ground. On some devices functions of pins 2 and 3 are reversed.

1. Use wire strippers to remove a portion of the cable jacket.
2. Remove at least 3/16" (5 mm) of insulation from each of the wires.
3. Insert the wires into correct terminal using the included 5-pin captive screw connector.
4. Attach the 5-pin connector block to the **RS-232** port on the AT-OME-RX31.

RELAY Connector

The **RELAY** port allows the control of screens, curtains, and other devices. Use a 48 V DC relay with no more than 1 A current draw.

When the AT-OME-RX31 is powered-on or rebooted, **C1** and **C2** are set to the Normally Open (NO) state.

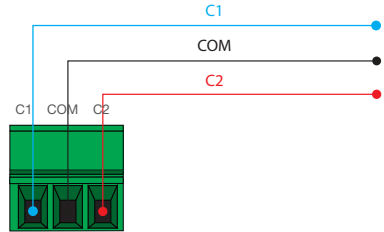
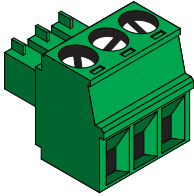

1. Use wire strippers to remove a portion of the cable jacket.
2. Remove at least 3/16" (5 mm) of insulation from each of the wires.
3. Insert the wires into correct terminal using the included 3-pin captive screw connector.
4. Attach the 3-pin connector block to the **RELAY** port on the AT-OME-RX31.

Installation

1. Connect an Ethernet cable from one of the **LAN** ports to the Local Area Network. Connect another Ethernet cable from one of the **LAN** ports to a display device, allowing IP control.
2. Connect up to category cables (CAT-5e or better) from compatible HDBaseT transmitters to the **INPUT 1** and **INPUT 2** ports.
3. Connect an HDMI cable from **INPUT 3** to a UHD/HD source device.
4. Connect an HDMI cable from the HDMI **OUTPUT** port to a display device.
5. OPTIONAL: Connect an audio output device to this port using the included captive screw block.
6. OPTIONAL: Connect a voltage-controlled device, such as an occupancy sensor, to the **TRIGGER I/O** port. Refer to **TRIGGER I/O Connector (page 5)** for wiring information.
7. OPTIONAL: Connect a serial cable from **RS-232 1** port to a display device. Refer to **RS-232 Connector (page 6)** for wiring information.
8. OPTIONAL: Connect a serial cable from **RS-232 2** port to a control system, to control the AT-OME-RX31 remotely. Refer to **RS-232 Connector (page 6)** for wiring information.
9. OPTIONAL: Connect an the **RELAY** port to the motor control for screens, curtains, and other devices. Use a 48 V DC relay with no more than 1 A current draw. Refer to **RELAY Connector (page 7)** for more information.
10. Connect the included 24 V DC power supply from this receptacle to an available AC outlet.

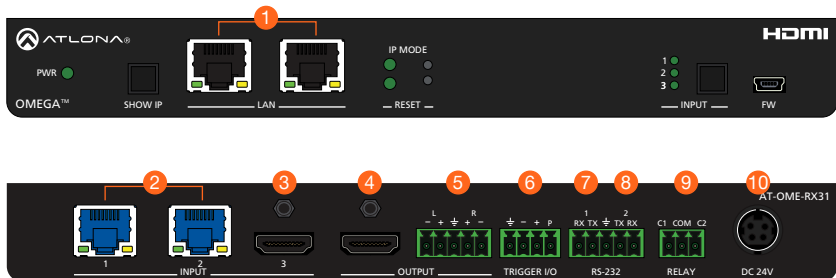

Mounting Instructions

The AT-OME-RX31 includes two mounting brackets, which can be used to attach the unit to any flat surface. Use the two enclosure screws, on the sides of the unit to attach the mounting brackets.

1. Using a small Phillips screwdriver, remove the two screws from the left side of the enclosure.

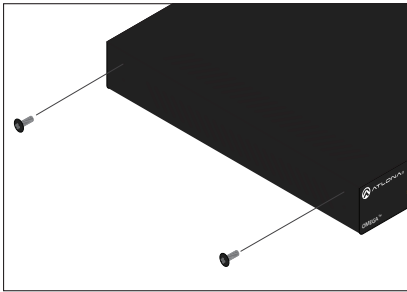

2. Position one of the mounting brackets, as shown below, aligning the holes on the side of the enclosure with one set of holes on the mounting bracket.
3. Use the screws from Step 1 to attach the mounting bracket.

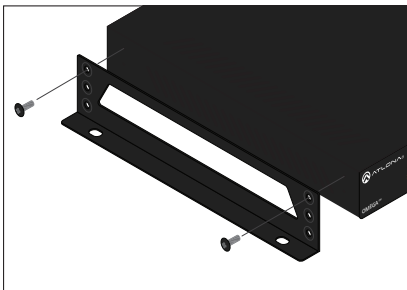

4. Repeat steps 1 and 2 to attach the second mounting bracket to the opposite side of the unit.
5. Mount the unit to a flat surface using the oval-shaped holes, on each mounting bracket. If using a drywall surface, a #6 drywall screw is recommended.

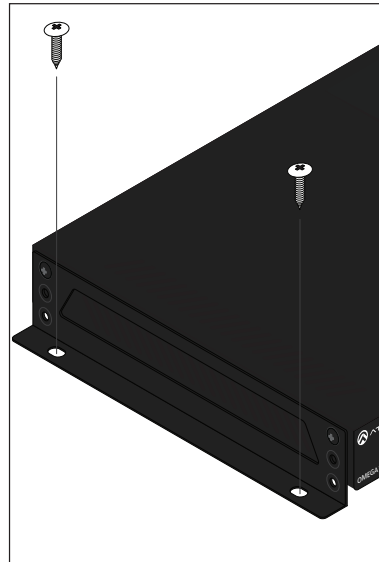

NOTE: Mounting brackets can also be inverted to mount the unit under a table or other flat surface.

IP Configuration

The AT-OME-RX31 is shipped with DHCP enabled. Once connected to a network, the DHCP server (if available), will automatically assign an IP address to the unit. If the AT-OME-RX31 is unable to detect a DHCP server within 15 seconds, then the unit will use a self-assigned IP address within the range of **169.254.xxx.xxx**.

Use an IP scanner, along with the MAC address on the bottom of the unit, to identify the unit on the network. If a static IP address is desired, the unit can be switched to static IP mode. The default static IP address is **192.168.1.254**.

Switching the IP mode

1. Make sure the AT-OME-RX31 is powered
2. Press and hold the **IP MODE** button, on the rear of the unit, for approximately five seconds.

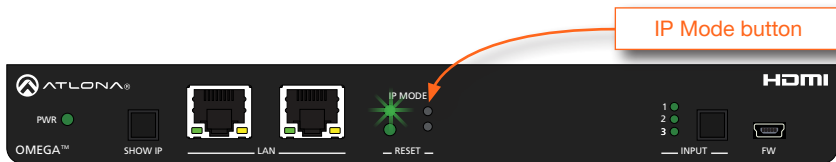

3. Release the button once the LED indicator, next to the **IP MODE** button, begins to flash green. The number of flashes will indicate the currently selected IP mode.

IP MODE LED flashes	Description
Two	Factory Static IP mode (IP address set to 192.168.1.254)
Four	DHCP mode

Displaying the IP Address

To display the IP address of the AT-OME-RX31, on the connected display, press and release the **SHOW IP** button on the front panel.

Resetting to Factory-Defaults

To reset the AT-OME-RX31 to factory-default settings, press and hold the **RESET** button for approximately 5 seconds. Release the button when the **RESET** LED indicator begins to flash. The LED indicator will flash three times to indicate that the reset procedure has completed.

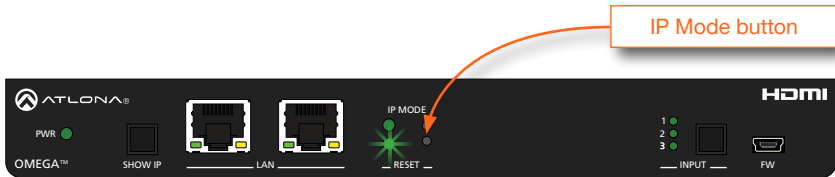

Velocity™ with Integrated AMS

For easy configuration of Atlona devices, Velocity with Integrated AMS is available from <https://atlona.com/ams> for free. Two options can be used for installation: The free easy-to-install AMS software (AT-AMS-SW) download or the AMS server hardware (AT-AMS-HW).

Once AMS has been set up:

1. Open a browser on the same network as AMS and go to the IP address of AMS. View the AMS installation instructions on how to find the IP address of the software, if necessary.
2. Enter the login information on the AMS web page, then click the **Login** button.
3. View the AT-OME-RX31 manual for more information.

Web GUI

The AT-OME-RX31 includes a built-in web GUI, which allows easy management and control of all features. Follow the instructions below to access the web GUI.



1. Set the IP mode of the AT-OME-RX31. Refer to [IP Configuration \(page 10\)](#) for more information.
2. Connect an Ethernet cable from one of the **LAN** port on the AT-OME-RX31 to the Local Area Network (LAN).
3. Connect an HDMI cable from the AT-OME-RX31 to a display, then press the **SHOW IP** button on the front panel to display the IP address.
4. Launch a web browser and enter the IP address of the unit.
5. The AT-OME-RX31 **Login** page will be displayed.
6. Enter the following information on the **Login** page. Login credentials are case-sensitive.



Login: **admin**
Password: **Atlona**



7. Click the **Login** button.

Front Panel LED Indicators

The LED indicators on both the front and rear of the unit provide basic information on the current status of the unit.

PWR		Description
Solid green		Unit is receiving power using the included 24 V DC power supply.
Off		Unit is not powered.

1, 2, 3		Description
Solid green		The input is the currently selected input.
Off		The input is not selected.

IP MODE		Description
Flashes green (4x)		Flashes four times to indicate that the unit is being set to DHCP mode. Refer to IP Configuration (page 10) for more information.
Flashes green (2x)		Flashes four times to indicate that the unit is being set to DHCP mode. Refer to IP Configuration (page 10) for more information.
Off		Normal operating mode.

Notes

Notes

Notes

English Declaration of Conformity

The English version can be found under the resources tab at:

<https://atlona.com/product/at-ome-rx31/>.



Chinese Declaration of Conformity 中国RoHS合格声明

由SKU列出於:

<https://atlona.com/about-us/china-rohs/>.



The terms HDMI, HDMI High-Definition Multimedia Interface, and the HDMI Logo are trademarks or registered trademarks of HDMI licensing Administrator, Inc.