



TELGUARD

TG-7FP Sole Path Communicator Installation & Operation Guide



COMPANY CONFIDENTIAL
For use by TELGUARD customers only.
Distribution to other parties strictly prohibited.

November 20, 2020

Part Number 56052401 - Rev. A

© 2020 Telguard. Telguard and the Telguard Logo are registered trademarks of
Telular Corporation | Telular is a business unit of AMETEK, Inc. All Rights Reserved.



Important Note

The registration form must be completed before leaving for the job site to install the Telguard product. Use our dealer site at www.telguard.com to register the communicator in real time.

Foreword

Dealers purchase Telguard cellular communicators for the quality, features and total value they represent. The Telguard TG-7FP meets UL and ULC standards for Commercial Fire and Commercial Burglary systems. The Telguard TG-7FP may be used in Commercial Fire, Commercial Burglary, or combination Fire/Burg systems as the sole communication path, when applicable features are enabled.

Technical Support

Technical support for all Telguard products is available:

Toll Free: 800-229-2326, option 9
Monday - Saturday 8am - 8pm ET

About this Manual

This manual assumes that you have basic security system installation skills such as measuring voltages, stripping wire, properly connecting wires together, connecting wires to terminals, and checking phone lines. It also assumes that you have a familiarity with the proper installation and programming tasks related to various alarm panels.

The material and instructions covered in this manual have been carefully checked for accuracy and are presumed to be reliable. However, Telguard assumes no responsibility for inaccuracies and reserves the right to modify and revise this manual without notice.

It is our goal at Telguard to always supply accurate and reliable information. To report a discrepancy you find in this documentation, please send an email message to:

Customerservice.telular@ametek.com

Or, write to:

Telguard Technical Services
3225 Cumberland Blvd
Suite 300
Atlanta, GA USA 30339

Repair and Warranty

If trouble is experienced with the *Telguard Cellular Alarm Communicator* please contact Telguard Technical Support for troubleshooting, repair, and/or warranty information. The dealer or end user should not attempt any repair to *the Telguard Cellular Alarm Communicator*. Repair of this equipment should only be referred to qualified technical personnel.

Telguard will repair or replace (our option) inoperative units for up to two years from date of manufacture. This excludes damage due to lightning or installer error. Unauthorized modifications void this warranty. Not responsible for incidental or consequential damages. Liability is limited to price of unit. This is the exclusive warranty and no other warranties will be honored, whether expressed or implied.

An RMA must be assigned before returning product. You may obtain an RMA via phone at 800-229-2326 option 1, or via email at returns.telular@ametek.com.

NOTE: RMA number must be on the outside of box or product will not be accepted.

Future Testing and Limitations on Use

The Telguard TG-7FP is part of an advanced design alarm communication system. It does not offer guaranteed protection against burglary and fire. Any alarm communication system is subject to compromise or failure.

The communicator will not work without power. Electrically powered devices will not work if the power supply is off for any reason, however briefly.

The cellular radio network, needed to transmit alarm signals from protected premises to a central monitoring station, may be inoperative or temporarily out of service. Cellular radio networks are also subject to compromise by sophisticated methods of attack.

This equipment, like any other electrical device, is subject to component failure. Although this equipment is designed to be long lasting, the electrical components could fail at any time.

Due to these limitations, we recommend that if the automatic self-test feature is not enabled, other arrangements be made with the user to test the system at least once every three months. Moreover, arrangements should also be made for on-site inspection/test by a licensed alarm installer at least once each year.

Terms and Conditions for Use of Telguard Product

These Terms and Conditions are a legal contract between you and Telguard for the title to and use of the Product. BY RETAINING AND USING THE PRODUCT YOU AGREE TO THE TERMS AND CONDITIONS INCLUDING WARRANTY DISCLAIMERS, LIMITATIONS OF LIABILITY AND INDEMNIFICATION PROVISIONS BELOW. *IF YOU DO NOT AGREE TO THE TERMS AND CONDITIONS, DO NOT USE THE PRODUCT AND IMMEDIATELY RETURN THE UNUSED PRODUCT FOR A COMPLETE REFUND.* You agree to accept sole responsibility for any misuse of the Product by you; and, in addition, any negligent or illegal act or omission of you or your agents, contractors, servants, employees, or other users of the Product so long as the Product was obtained from you, in the use and operation of the Product.

INDEMNIFICATION OF TELGUARD

YOU SHALL INDEMNIFY, DEFEND, AND HOLD HARMLESS TELGUARD FOR ANY OF THE COST, INCLUDING REASONABLE ATTORNEYS' FEES, AND FROM CLAIMS ARISING OUT OF YOUR, YOUR CLIENTS' OR OTHER THIRD PARTIES' USE OR OPERATION OF THE PRODUCT: (i) FOR MISUSE OR IN A MANNER NOT CONTEMPLATED BY YOU AND TELGUARD OR INCONSISTENT WITH THE PROVISIONS OF THIS MANUAL; (ii) IN AN ILLEGAL MANNER OR AGAINST PUBLIC POLICY; (iii) IN A MANNER SPECIFICALLY UNAUTHORIZED IN THIS MANUAL; (iv) IN A MANNER HARMFUL OR DANGEROUS TO THIRD PARTIES; (v) FROM CLAIMS BY ANYONE RESPECTING PROBLEMS, ERRORS, OR MISTAKES OF THE PRODUCT; OR (vi) COMBINATION OF THE PRODUCT WITH MATERIAL MODIFICATION OF THE PRODUCT OR USE OF THE PRODUCT IN AN ENVIRONMENT NOT PROVIDED, OR PERMITTED, BY TELGUARD IN WRITING. THE PARTIES SHALL GIVE EACH OTHER PROMPT NOTICE OF ANY SUCH COST OR CLAIMS AND COOPERATE, EACH WITH THE OTHER, TO EFFECTUATE THIS INDEMNIFICATION, DEFENSE AND HOLD HARMLESS.

WARRANTY and LIMITATIONS

TELGUARD WILL REPAIR OR REPLACE (OUR OPTION) INOPERATIVE UNITS FOR UP TO TWO YEARS FROM DATE OF MANUFACTURE. EXCLUDES DAMAGE DUE TO LIGHTNING OR INSTALLER ERROR AS WELL AS UNITS THAT INCORPORATE MATERIAL, OR USED IN A MANNER OR ENVIRONMENT, NOT SPECIFICALLY AUTHORIZED IN THIS MANUAL. UNAUTHORIZED MODIFICATIONS VOID THIS WARRANTY. NOT RESPONSIBLE FOR INCIDENTAL OR CONSEQUENTIAL DAMAGES. LIABILITY LIMITED TO PRICE OF UNIT. THIS IS THE EXCLUSIVE WARRANTY, IN LIEU OF ALL OTHER WARRANTIES INCLUDING IMPLIED WARRANTIES OF MERCHANTABILITY, TITLE, DELIVERY, INFRINGEMENT OR FITNESS FOR A PARTICULAR PURPOSE AND NO OTHER WARRANTIES WILL BE HONORED, WHETHER EXPRESSED OR IMPLIED.

Table of Contents

Important Note	i
Foreword	i
General Description and Operation	1
<i>Information Related to Software Settings</i>	2
Features	4
<i>Operating Mode</i>	4
<i>Multiple Alarm Format Support</i>	4
<i>Complete Supervision of Communication Path</i>	4
<i>Link Supervision</i>	5
<i>Complete Power Supervision</i>	5
<i>Telguard Automatic Self-Test Report</i>	6
<i>Telguard Check Status Capability</i>	6
<i>Programmable Supervisory Trip Output (STC) Relays</i>	6
<i>Post-Installation Remote Programming</i>	7
<i>Diagnostic and Status LEDs</i>	7
<i>Complete Factory Reset Option</i>	7
<i>UL and ULC Compliance</i>	8
Getting Ready	8
<i>Dealer Account Establishment</i>	8
<i>Pre-Installation Checklist</i>	8
Installation	9
<i>Summary</i>	9
<i>Step 1: Register the Telguard Communicator</i>	9
<i>Step 2: Physically Install the TG-7FP in Desired Location</i>	10
<i>Step 3: Determine Antenna Placement for Best Performance</i>	11
<i>Step 4: Connect to Panel DACT and Activate</i>	12
<i>Step 5: Connect Supervisory Trip Outputs</i>	13
<i>Step 6: Connect and Test the Trip Input (optional)</i>	14
<i>Step 7: Connect Tamper Switch (optional in fire-only systems/required for burg)</i>	14

<u>Appendix 1 – Connection Guide</u>	<u>15</u>
<i>Wiring Diagrams</i>	15
<i>Tamper Switch Installation for UL/ULC Commercial Burglary</i>	17
<i>RJ-45 Jack Pin Assignments</i>	18
<i>DC Terminal Strip Pin Assignments</i>	18
<i>Main Terminal Strip Pin Assignments</i>	18
<i>Compatible Alarm Panels</i>	19
<u>Appendix 2 – Troubleshooting Guide</u>	<u>20</u>
<i>LED Indicator Guide – Normal Operating Mode</i>	20
<i>Troubleshooting Quick Reference Table</i>	21
<i>LED Indicator Guide – RSSI Mode</i>	22
<u>Appendix 3 – Commercial Fire Sole Path Installation</u>	<u>23</u>
<i>TG-7FP Signal Strength</i>	23
<i>Configure Alarm Panel for Sole Path</i>	23
<u>Appendix 4 – Commercial Fire 6-hour Supervision</u>	<u>24</u>
<u>Appendix 5 – Compliance with UL and ULC Standards</u>	<u>24</u>
<u>Appendix 6 – Detailed Specifications</u>	<u>25</u>
<i>Dialer to Interface Electronics</i>	25
<i>Power</i>	25
<i>Digital Cellular Radio and Other Specifications</i>	25
<u>Appendix 7 – Accessories</u>	<u>26</u>

General Description and Operation

The Telguard® TG-7FP is a cellular radio alarm transmission device used to provide a sole transmission path (cellular) for commercial alarm panels. The TG-7FP can also be used as either a Primary or Secondary Path device when an alternate communications path is connected to another FACP-Telco interface or DACT. In such cases, the panel determines the alarm reporting path. When transmitting an alarm signal, the TG-7FP obtains its data from the alarm panel by way of the DACT interface. The TG-7FP will obtain all alarm signal information including monitoring station phone number, account number and all zones for every alarm transmission. The TG-7FP handshakes with the alarm panel and causes it to transmit the alarm data. The TG-7FP encodes the alarm data and transmits it to the Telguard Communication Center (TCC) over the cellular network. The TCC performs a function similar to a central station receiver and issues the transmission acknowledgement when the last message in the transmission is received. After decoding and reformatting, the alarm signal is routed over a telco line (Public Switched Telephone Network - PSTN) or via the Internet (IP) to the desired alarm company central station for action.

In a typical alarm installation, the TG-7FP is installed in the same area as the host alarm system and is connected directly to the host alarm panel via the TG-7FP's RJ-45 jack. Two programmable System Trouble Condition (STC) relays are available for connection to the host alarm panel's trip zone input terminals in order to provide Telguard trouble signals to the alarm panel. Additionally, automatic self-test and check status request signals are transmitted exclusively over the cellular network to the Telguard Communication Center. The TG-7FP receives operating power from the host alarm panel (either regulated 12- or 24-volt DC), and all cellular monitoring and supervisory functions are built in. No extra modules are required.

The UL Listed equipment at the TCC plays a key role in the operation of every Telguard device. All Telguard communicators utilize the TCC due to the panel alarm signal format encoding and decoding requirements used in packet-data transmissions over the digital cellular network. The TCC also manages the real-time databases for cellular accounts and a complete history of every communicator's operating conditions. These conditions include programming setup information, cellular alarm transmission information, supervisory trouble information, status information, and automatic self-test information.

The TG-7FP is offered in two versions configured to work either with the AT&T or Verizon networks:

Model	Application	UL/ULC Standards
TG-7FP-A (AT&T)	Sole Path Communication for Fire and Burglary Systems in United States and Canada *	UL 1610, ULC-S304, UL 864, and ULC-S559
TG-7FP-V (Verizon)	Sole Path Communication for Fire and Burglary Systems in United States *	UL 1610, and UL 864

* Can be used as either a Primary or Secondary Path device when an alternate communications path is connected to another alarm panel DACT interface. In such cases, the panel determines the alarm reporting path.

NOTE: While working in Canada, TG-7FP-A may use Rogers Wireless, Bell Mobility, Telus, or SaskTel networks.

Information Related to Software Settings

NOTICE TO USERS, INSTALLERS, AUTHORITIES HAVING JURISDICTION, OTHER INVOLVED PARTIES

FIRE SYSTEM INSTALLATIONS: This product incorporates field-programmable software. In order to comply with the requirements in the Standard for Control Units and Accessories for Fire Alarm Systems, UL 864, and/or Standard for Equipment for Fire Signal Receiving Centres and Systems, ULC-S559, certain programming features or options must be limited to specific values or not used at all as indicated below.

Program feature or option	Permitted in UL 864? (Y/N)	Possible settings	Settings permitted in UL 864
Link Supervision when used as a Sole Path	Y	Disabled, 200 seconds, 5 minutes, 60 minutes	200 seconds, 5 minutes, 60 minutes
Automatic Self-Tests when used with an alternate communication path	Y	Disabled, 6 hours, Daily, Weekly, Monthly	6 hours [#]
No Service Condition (NSC) delay	Y	30 seconds, 60 seconds, 3-, 5- 10-, 20-, 30-, 45-, 60-, 1440- minutes	No more than 3 minutes

Program feature or option	Permitted in ULC-S559? (Y/N)	Possible settings	Settings permitted in ULC-S559
Link Supervision	Y	Disabled, 180 seconds	180 seconds
No Service Condition (NSC) delay	Y	30 seconds, 60 seconds, 3-, 5- 10-, 20-, 30-, 45-, 60-, 1440- minutes	No more than 60 seconds

[#] 6 hours is specified in UL 864 10th Edition (published in 2014); the 9th Edition (published in 2003) specified 24 hours (daily).

BURGLARY SYSTEM INSTALLATIONS: In order to comply with the requirements in the Standard for Central-Station Burglar-Alarm Units, UL 1610 and Standard Line Supervision, the TG-7FP must meet these requirements:

The TG-7FP communicator must be used in one of the following configurations:

- As a primary communicator, single line-200 second supervision; or
- As a secondary communicator line for a DACT (supervision not required). Every 24 hours, a check-in signal must be sent from the communicator to the central station over the primary dialer and each communication path shall be monitored for integrity (DACT shall have line monitoring enabled and the TG-7FP shall have cellular connection supervision enabled).

Additionally:

- When the heartbeat transmission over the LTE network is enabled, the communicator can provide Standard Line Security over the LTE channel.
- The communicator shall be powered from the UL Listed alarm control panel.
- The provided tamper switch shall be connected directly to an input zone on the control panel, and the zone shall be designated as the zone for Tamper Protection. Tamper wires and all other wires connecting the communicator to the panel shall be in rigid or flexible metal conduit.

BURGLARY SYSTEM INSTALLATIONS IN CANADA: In order to comply with the requirements in the Standard for Control Units, Accessories and Receiving Equipment for Intrusion Alarm Systems, ULC-S304, the TG-7FP must meet these requirements (Security Level II):

The TG-7FP communicator must be used in one of the following configurations:

- Passive communication system line security level P1 (single communication channel); or
- Line security level P2 (used as backup in conjunction with another communication path such as a DACT). There is no heartbeat sent in this configuration, only periodic test transmissions.

Additionally:

- Every 24 hours, a test transmission must be sent to the signal receiving centre over each communication path. Each communication path shall be monitored for integrity (DACT shall have line monitoring enabled and the TG-7FP shall have cellular connection supervision enabled). For Level P2, the working communication path shall report the failure of the other channel within 240s.
- The TG-7FP shall be used in conjunction with a ULC or c-UL Listed Control Unit/Alarm Panel, which will supply power to operate the communicator.
- STC1 and STC2 shall be connected from the communicator to the control panel and designated for general trouble conditions.
- The provided tamper switch shall be connected directly to an input zone on the control panel, and the zone shall be designated as the Tamper Protection zone. Tamper wires and all other wires connecting the communicator to the panel shall be in rigid or flexible metal conduit.

Features

This section summarizes the key features of the Telguard TG-7FP.

Operating Mode

The TG-7FP communicator is a sole path cellular Data/SMS transmission device that is installed at the protected premises to provide alarm transmission for fire and/or burglary alarm systems over the applicable cellular network where there is no wireline service available. The TG-7FP can also be used as either a Primary or Secondary Path device when an alternate communications path is connected to another alarm panel DACT interface. In such cases, the panel determines the alarm reporting path.

Multiple Alarm Format Support

The Telguard TG-7FP supports multiple alarm communication formats.

NOTE: The communicator's default program setting is for auto detection of the panel alarm format.

Auto Format Detect feature allows the communicator to adapt to receive any listed format. If the alarm panel's format is changed for any reason, the communicator will adjust to accept the new format.

See Appendix 1 for a list of compatible alarm formats and compliance requirements.

Complete Supervision of Communication Path

The communicator continuously supervises the cellular communication path. If communication path becomes inoperative, the communicator can generate a relay trip output that can be connected to a zone input of the host alarm panel and/or used to control remote annunciation devices.

No Service Condition (NSC)

A no service condition (NSC) occurs when the TG-7FP is unable to register with the cellular network.

NSC can be configured to trip the supervisory relay output (STC relay) after a programmable period of time. The STC LED will flash 4 times immediately after losing cellular service and dial-tone will cease to be provided, independent of the STC assertion and programmed assertion delay. NSC restoral occurs immediately after cellular service has been acquired.

Radio Communications Failure Condition (RFC)

Radio communications failure condition (RFC) occurs when the communicator is unable to transmit over the cellular network even with acceptable signal strength. When RFC is declared, the STC LED will flash 5 times, dial-tone will cease, and the STC relay will trip as programmed. Restoral of this condition occurs after 10 minutes or when a message is received from the TCC.

NOTE: When End-to-End acknowledgement feature is enabled, a message that fails to deliver to the Central Station will trigger an RFC condition.

Panel Presence Failure (PPF)

Panel presence failure condition (PPF) occurs when the communicator is unable to detect the presence of the alarm panel. PPF is indicated by the STC LED flashing 7 times. A supervisory report is generated and sent to the TCC for Central Station delivery upon detection of PPF. Restoral of this condition occurs when the alarm panel is detected as present for the selected delay time.

NOTE: The factory default for PPF is Disabled and needs to be Enabled for its use. For the PPF feature to work, Tip, Ring, and the return connections for Tip and Ring must be connected between the panel and the communicator.

UL/ULC Compliance Note: *In Burglary installations, PPF must be set to Enabled.*

Link Supervision

In order to satisfy UL and ULC requirements, the TG-7FP can enable link supervision at preset intervals. Once the TG-7FP is provisioned with the Link Supervision option, the TCC constantly monitors the cellular path and sends a specific message to the central station if the path is broken or a compromise attempt is made. After the initial account activation is done, the installer must verify the Link Supervision by turning off the communicator and making sure an alarm with the specific code is delivered.

Standard Line Security (UL Burglary Systems Only)

The TG-7FP is rated single/dual line transmission, Standard Line Security. For dual line transmission, the primary path is connected to the panel's DACT for Line 1; the communicator's cellular path is secondary and is connected to the panel's DACT for Line 2.

Complete Power Supervision

Low Power Failure (LPF)

Low Power Failure condition (LPF) is detected immediately when the DC power drops below 7.5VDC. When this condition is detected, the STC LED blinks once, the Power LED turns off, and the STC trip output is activated after a preset time (2 hours). When DC power returns to normal (≥ 8 VDC), the Power LED turns on immediately and the STC trip output restores after 60 seconds.

Dial Tone Failure (DTF)

The TG-7FP provides a voltage supply and other signaling to the panel like a telephone central office. The communicator continuously monitors the circuit that provides dial tone to the alarm panel. The TG-7FP will supply 30VDC by default but can be configured to supply 40VDC, as needed. A Dial Tone Failure (DTF) occurs when the communicator is unable to provide proper telephone signaling to the panel (voltage supplied drops while the alarm panel is on-hook). The STC LED will flash 6 times and the STC relay will trip.

NOTE: This condition will require contacting Telguard Technical Support for resolution.

Catastrophic Failure (CF)

Catastrophic Failure (CF) is any condition that causes the communicator to stop functioning at all levels. The most common CF is a power failure event. The STC1 and STC2 trip outputs are activated and the visible indication is loss of all LED activity.

Telguard Automatic Self-Test Report

The automatic self-test signal schedule is programmable as prescribed when the communicator is registered. The central station receives the automatic self-test report in the same format that the alarm panel normally uses for communication over the Telco line. The self-test code and testing frequency are set during registration and can accommodate any code the Central Station expects.

The TCC captures all current and historical data pertaining to the operation of the communicator when it processes the automatic self-test signal. This data contains current operational status (C.O.S.) of the communicator such as "All OK" or any combination of identified trouble conditions as well as the current signal strength. In addition, the data also contains historical data for supervisory events that occurred since the last self-test or check status report signal was transmitted. This additional information is available by visiting www.telguard.com (dealer log-in credentials required).

Telguard Check Status Capability

Although the communicator has the capability for an automatic self-test, a separate feature is provided for determining the current operational status of every Telguard communicator. This feature is called Check Status and is used to provide real-time operational status for the communicator on-demand. It is useful in resolving STC events that are reported by the alarm panel to the central station. Check Status is available via www.telguard.com.

Check Status causes the communicator to upload current operational status data and historical data, just as the automatic self-test described above, except that the resulting status is held in the database at the TCC for review and is not forwarded on to the central station.

Programmable Supervisory Trip Output (STC) Relays

The communicator has two supervisory relay trip outputs available (STC1 normally open and STC2 normally closed). Both are energized in a powered-up state when no system troubles exist. This enables a supervisory trouble code to be transmitted to the central station when connected to an alarm panel's 24-hour instant input zone. The trouble conditions that trigger the STC relays are programmable via the dealer portal, www.telguard.com, to meet any installation requirement.

Note: If using a supervised zone to monitor for the STC relay, please make sure that you follow resistance requirements of the alarm panel for supervision. Refer to manual supplied with the panel for further guidance.

The following supervisory features or combination of features are programmable to trip the STC relays in order to meet a variety of installation requirements:

- Low Power Failure condition (LPF)
- No Service Condition (NSC)
- Radio Failure Condition (RFC)

The following system trouble features are embedded in the communicator for tripping the STC relays and cannot be changed:

- Dial Tone Failure (DTF): *insufficient voltage on connection to panel DACT*
- Communicator not activated at TCC: *communicator requires activation for use*
- Catastrophic Failure (CF): *all power is lost*
- Transmit Disable command received from TCC: *used when a runaway dialer situation is detected or by Customer Service, for example*

UL/ULC Compliance Notes:

- *In Fire installations, STC2 (normally closed) cannot be used for communicating with the alarm panel; only STC1 (normally open) can be used.*
- *In Burglary installations, when an alternate communications path is connected to another alarm panel-Telco interface or DACT, an STC relay shall be programmed to trip on NSC and wired to an available zone on the panel.*

ULC Compliance Notes:

- *TG-7FP devices are suitable for use in Security Level 2 applications.*
- *For commercial fire installations, only the Active/Sole Path communication shall be used.*

Post-Installation Remote Programming

To continue to meet compliance requirements, once a communicator is installed it cannot be remotely reprogrammed or receive updated firmware from Telguard Technical Support without manual on-site intervention. To change the device settings or accept updated firmware, follow these steps:

- Locate and press either of the RSSI buttons on the TG-7FP, holding it for at least 5-7 seconds (use the provided tool or an unbent paper clip if using side button).
- LED 5 will flash, indicating that a message has been sent to initiate a Maintenance Window.
- The maintenance window will last for 10 minutes after receipt of the device message.
- Log into the dealer portal at www.telguard.com and make the necessary configuration changes to the device, within the observed maintenance window (10 minutes).
- No device configuration changes can be made outside of the maintenance window.

NOTE: All alarm functions and transmissions will continue to operate during the Maintenance Window.

Diagnostic and Status LEDs

Seven active LEDs are provided as a useful aid during installation and give installers an immediate visual indication of system status. The LEDs serve as indicators for activation, system trouble conditions, power, and communication indicators. They can also provide a signal strength indication, similar to the signal strength bars on a cellular phone. See Appendix 2 or the installation section for details.

Complete Factory Reset Option

A special function within the TG-7FP allows you to perform a complete Factory Reset on the communicator. This reset will change all communicator settings back to a factory default configuration.

NOTE: Never attempt to do a Complete Factory Reset on an active account because the communicator will need to be re-activated.

To begin the factory reset, follow these steps:

- Power cycle the device. For the first three seconds after power up, all LEDs will be lit solid.
- While the communicator shows this pattern, press and hold either of the RSSI buttons (use the provided tool or an unbent paper clip if using side button). After 15 seconds of button press, the LEDs will begin to sequentially turn on and off in a cascading pattern, indicating the factory reset is taking place.
- Release the button. After the factory reset concludes, the LEDs will go back to normal status.

UL and ULC Compliance

The TG-7FP is certified as complying with UL and ULC Standards for Commercial Fire and Commercial Burglary installations. The chart on Page 1 shows the associated UL and ULC Standards. Certificates of Compliance are available at www.telguard.com.

To maintain compliance, the alarm panel must also be UL, ULC, or cUL Listed for commercial fire and/or commercial burglary use as appropriate.

ULC Compliance Note: *For Commercial Fire installations in Canada, the radio frequency warning label (supplied) must be affixed to the outside front cover of the TG-7FP device to maintain compliance.*

Getting Ready

The communicator can only be activated when all necessary accounting information has been added to the customer database located at the TCC (i.e., the communicator has been registered). The database includes information about the customer account, communicator location, and system test plan information.

Dealer Account Establishment

A Dealer Account must be established prior to registration of any Telguard communicator. This can be accomplished by visiting www.telguard.com and completing the necessary information under “Dealer Signup”. This is a one-time event and an acknowledgment from Telguard Customer Service will include a Dealer Account Number that will be used for all Telguard Digital registrations. Telguard communicators can be registered and activated once the Dealer Account has been established.

Pre-Installation Checklist

Before attempting to connect the communicator to the alarm panel, please make sure you have all the proper parts before you go to the job site. The following items are shipped with each TG-7FP:

- Telguard Cellular Communicator
- Cellular Antenna
- Pluggable screw terminal blocks (2-, 2-, & 6- position)
- Button Activation Tool for operating side buttons
- Quick Install Guide
- Frequency Warning Label to be applied for installations in Canada

NOTE: The communicator registration should be completed in advance to avoid installation delays

You must also have certain installation test tools:

- Screws and a screwdriver will be required to attach the communicator and antenna to the wall.
- To connect the STC relay outputs, trip input, or tamper to the alarm panel, solid or stranded electrical wire will be required. The terminal strips can accommodate solid or stranded wire from 16 to 22 gauge in size.
- A standard telephone or lineman's butt-set is recommended for verifying communication between the panel and the communicator.

Installation

Summary

The following are steps necessary to install the communicator properly.

NOTE: IF YOU DO NOT PROCEED IN THE ORDER AND MANNER PRESCRIBED, YOU MAY NOT COMPLETE THE INSTALLATION IN THE TIME DESIRED.

These steps are summarized below and explained in detail in the remainder of this manual.

1. Register for Telguard service
2. Physically install the TG-7FP device
 - Mount the TG-7FP device in desired location
 - Complete all power-related wiring connections
3. Determine antenna placement for best performance
 - Connect antenna
 - Measure Received Signal Strength (RSSI)
 - Consider other antenna options
4. Connect to Panel DACT and Activate
5. Connect supervisory trip outputs
6. Connect trip input (optional)
7. Connect Tamper Switch (required for burglary systems; optional for fire systems)

This installation approach provides the alarm installer with the easiest and fastest method of properly installing a TG-7FP device. Please follow the instructions carefully and if you should need assistance or have any questions, please call Telguard Technical Support at 1-800-229-2326 extension 9.

NOTE: Dealer Account Establishment and Telguard Registration must be complete prior to Installation.

Step 1: Register the Telguard Communicator

Installation Tip: Register for Telguard service prior to leaving for the job site to avoid a second trip.

The registration form may be completed online through our 24/7 dealer portal www.telguard.com.

The desired features and programmable options for any installation are selected during the registration process. This includes STC strategy, Trip-Input enabling, and added value services like HomeControl Flex and Standard Line Security.

UL/ULC Commercial Fire Sole Path Features

- Link Supervision: When registering a TG-7FP device for commercial fire applications, use the link supervision option in accordance with local requirements (5-minute supervision or 60-minute supervision in the U.S. or 180-second supervision in Canada).
- End-to-End Acknowledgment feature: When enabled an RFC condition will occur when the captured signal is not delivered to the Central Station as expected.

Decide on a STC Trip Output Strategy

The communicator provides the host alarm panel with two supervisory trip outputs for reporting a Telguard system trouble code to the central station. The supervisory trip outputs are programmable to suit various installation requirements. The programming options for these supervisory trip outputs can be any combination of the following:

- Always Off: Disables all relay supervisory functions.
- LPF: Trips two hours after low power failure is detected. Restores 60 seconds after power is restored.
- NSC: Trips after a 60-second delay (delay is programmable) on no service condition due to loss of RF signal strength. Restores after RF signal strength is available.
- RFC: Trips on radio failure to communicate with the TCC. Restores after 10 minutes.

UL Compliance Note: *NSC delay must be 3 minutes or less in accordance with UL 864.*

ULC Compliance Note: *NSC delay must be 60 seconds or less in accordance with ULC-S559.*

Optional Trip Input

When the input is tripped, a supervisory message is sent to the central station via the TCC. This allows an external relay, separate from the alarm panel, to be connected to the communicator in order to provide independent sensor input for other functions, such as tamper detection.

The message that is sent from the TCC to the central station is configurable in www.Telguard.com. The communicator will automatically be configured with a template that allows configuration of the trip input feature, including the message that is sent to the central station. If the communicator is configured to report restorals, the contact closure will also be reported.

Swinger Function

The swinger function is designed to reduce the incidence of excessive messaging and alarms due to faulty equipment or installation. If enabled, the swinger function will discontinue sending trip input messages to the TCC once 10 trip events are detected within a 10-minute period. The communicator will resume sending trip input messages to the TCC after a 10-minute period without trip events.

Step 2: Physically Install the TG-7FP in Desired Location

Identify Location for Placing the TG-7FP Device and Mount

Do not install the communicator in an area where the general public could reasonably be within 20cm (8 inches) of the antenna.

*NOTE 1: Optimum RF performance can usually be found at the highest point within a building with the fewest number of walls between the communicator's **antenna and the outside of the premises**.*

NOTE 2: To avoid interference with other electronic devices operating in the area, avoid mounting the communicator's antenna near other electronic devices.

NOTE 3: The communicator's dipole antenna is designed for indoor installations only.

Prior to mounting, determine how you will make all power and signal connections. There are three available knockouts on the TG-7FP enclosure for accepting ½" conduit connectors. Punch out the needed knockouts by placing a screwdriver in the center of the knockout and strike the screwdriver with a hammer. Conduit hubs must be connected to the conduit before the hub is connected to the enclosure.

Care should be taken to ensure that a large metal object such as a refrigerator or a metal cabinet is not located on the opposite side of the wall. If moving the communicator to a different location is not practical, you may need to purchase an extension cable to remote the antenna in order to receive adequate radio signal strength. Choose a high, visually secure spot using the guidelines below.

Tips for Improved Radio Signal Reception

- The higher the antenna the better. Start in the drop ceiling above the communicator and proceed from there, up to the roof if necessary.
- Remember, the antenna should be as inconspicuous as possible for greatest visual security.
- Try to keep the antenna away from sources of RF interference, including pumps, compressors, ovens, etc., or where metal objects can shield it or otherwise block the cellular radio RF signal.
- Place the antenna perpendicular to the ground, pointing either straight up or down. Do not mount the antenna horizontally.

Mount the communicator to the wall or other surface near the alarm panel. Care should be taken to avoid equipment that may make receiving a clear cellular signal difficult.

- Attach earth ground to the grounding screw located on lower left-hand corner of printed circuit board assembly and permanently mount the Telguard enclosure.
- Install mounting screw (not supplied).
- Slide the enclosure onto the screw.
- Verify communicator is secured by placing additional screws in lower mounting holes.

Complete All Power-Related Wiring Connections

Power to the communicator is sourced from the host alarm panel 12VDC or 24VDC auxiliary output. Connect the power and ground connections into the respective DC and GND connections on the TG-7FP using a supplied 2-position terminal block.

NOTE: Do not use a plug-in adapter or other non-panel power source on the TG-7FP.

The wiring used for power and other connections on the communicator can be either solid or stranded and should adhere to the following recommendations:

<u>Recommended Wire Size</u>	<u>Length Not to Exceed</u>
22 ga	10 ft
20 ga	20 ft
18 ga	60 ft (20 ft max. for fire systems)

UL/ULC Compliance Note: All wiring shall be in accordance with NFPA 72, NFPA 70, and with C22.1, Canadian Electrical Code, Part I, Safety Standard for Electrical Installations, Section 32.

Step 3: Determine Antenna Placement for Best Performance

Connect Antenna

The Telguard communicator is supplied with an antenna. In most cases the antenna can be mounted directly to the communicator. If necessary, the antenna may be moved to a better signal location using an extension cable and bracket accessory (not included). The performance of the antenna may be affected by the wall or materials contained within the wall chosen for mounting. These effects may not be clearly identified by RSSI monitoring alone. The wall materials may have a more pronounced effect on the antenna transmit band performance.

Measure Received Signal Strength (RSSI)

Measure the received signal strength by pressing and releasing either of the RSSI buttons (use the provided tool or an unbent paper clip if using side button). This switches the LEDs to signal strength mode. If you do not obtain the recommended minimum signal strength with the antenna mounted directly to the communicator (see [LED Indicator Guide – RSSI Mode](#)), you will need to use an extension cable (not included) to locate the antenna in an area with better reception. Generally, the higher the antenna the better.

If necessary, attach the extension cable to the communicator on one end and the antenna on the other, then slowly move the antenna to achieve maximum signal strength by pausing at each location for 6 seconds to allow enough time for the communicator to present an updated signal strength. Pick a spot where the most LEDs (up to four) are illuminated.

Consider Other Antenna Options

Antenna issues are unlikely unless the premises are located in a fringe network coverage area, in a building below ground level, or in a metal structure. Telguard offers a variety of high quality low-loss antenna cables as well as high gain antennas. These accessories are listed in Appendix 7.

Step 4: Connect to Panel DACT and Activate

Connect alarm panel to the communicator. Plug the cable from the modular jack of the alarm panel (DACT) into the RJ-45 jack of the communicator.

UL Compliance Note: *For Commercial Fire installations, all connections from the alarm panel and the Telguard communicator must be mechanically protected and no greater than 20 feet in distance.*

ULC Compliance Note: *For Commercial Fire installations, all connections between the alarm panel and the Telguard communicator must be in metal conduit and no greater than 18 meters in distance. The FACP and the Telguard communicator must both be located in the same room.*

Trip a zone on the alarm panel and confirm that the TG-7FP enables the alarm panel to transmit alarm events over the cellular radio network. The Telguard will confirm activation with the TCC if the registration form was completed prior to installation.

During processing of the first alarm signal over the cellular network, the communicator will transmit to the TCC all programming parameters along with the information (Central Station number and account code) from the alarm panel. Once this information is received, the TCC transmits a message back indicating that the communicator is activated. When this message is received the LEDs on the communicator will begin operating in normal mode and Activation LED 1 will remain on.

NOTE: *The initial alarm is to confirm registration and activate the communicator. This alarm will NOT be transmitted to the central station.*

Special LED Indications during Activation

If the communicator fails the activation process, it will be displayed on the LEDs.

- If LED 1 and LED 4 are flashing, the communicator has failed activation. The serial number is not in the database at the TCC. Clear the fault (see note below) and call Telguard Technical Support to verify proper registration before resending an alarm signal.
- If LEDs 1-5 are flashing, there is an activation error. The activation message was NOT received at the TCC. Clear the fault (see note below) and retry transmitting an alarm signal. If the communicator fails a second time to activate, check signal strength. If signal strength is OK, then call Telguard Technical Support for further assistance.

*NOTE: In order to clear the faults listed above, the RSSI button must be pressed twice. After the issue has been resolved and the unit cleared, **STEP 4 MUST BE REPEATED TO ACHIEVE SUCCESSFUL ACTIVATION OR THE COMMUNICATOR WILL NOT TRANSMIT ANY SIGNALS.***

System Status LEDs Table:

System Status LEDs	Activation Indications
LED 1-5 FLASHING	Failed Activation – Signal Too Weak
LED 1 & LED 4 FLASHING	Activation Error – Call Telguard Technical Support
LED 1 ON	Activation Successful

Verify Alarm Signal Transmissions Over Cellular

Trip several alarms on the alarm panel and verify that the central station received them by calling the central station operator. Use a lineman's butt-set in *MONITOR MODE* connected to the communicator's "T" and "R" test pins to "listen" to communications between the alarm panel and the TG-7FP.

If you are having problems getting reliable alarm signal transmissions, additional adjustments may be necessary.

- Recheck signal strength. You need at least RSSI = 2 ½ (*TWO LEDS ON SOLID AND THIRD FLASHING*) for adequate signal transmission. Also, check antenna connector and make sure it is seated correctly.
- Call Telguard Technical Support, 1-800-229-2326 option 9.

Step 5: Connect Supervisory Trip Outputs

Connect and test the supervisory trip outputs to the alarm panel.

Enabling of a local alarm or strobe light may be desirable when a trip is declared. The STC trip output can be used directly to activate a local signaling device, provided that the trip output is not needed to trip the alarm panel at the same time. If both a local signaling device and an alarm panel are required, then external relays are needed to provide additional uncommitted contacts.

Reprogram Alarm Panel to Send Proper Code

If necessary, reprogram the alarm panel to send proper alarm code when tripped by the communicator's supervisory output. Program zone restoral as desired.

Check Proper Operation of Telguard Supervisory Output

Check for proper operation of each programmed supervisory output by causing it to trip the alarm panel and making sure the proper LED illuminates and that the proper trouble code is reported to the central station. Skip the testing of any supervisory functions that have not been enabled. Note that the yellow LED 3 starts to flash when the alarm panel goes off-hook to report the alarm signal over cellular.

- No Service Condition (NSC): Disconnect the antenna from the TG-7FP. Check to see that the STC LED 2 flashes 4 times and if configured, alarm panel will detect the tripped STC after the selected period of time indicating loss of RF signal strength. Reconnect the antenna and check to see that the STC LED 2 goes off within the configured period indicating RF signal strength restored.

Step 6: Connect and Test the Trip Input (optional)

The trip input is connected to the external relay by wiring the external relay to the TRIP IN terminal (pin 6) of the terminal block, and the other side to the TRIP GND terminal of the same block (pin 5).

Note that trip inputs are commonly wired such that there is a 2.2k Ω resistor in parallel with the external relay, so that a tamper condition (e.g., a cut wire) can be detected. When the trip input functionality is being used, closing the trip contact will cause the communicator to send a message to the TCC, which in turn will cause the TCC to send a message to the central station. If the communicator is configured to report restorals, the contact opening will also be reported.

UL Compliance Note: *The trip input feature shall only be used for supplementary signaling. Initiating zones shall not be connected to the trip input.*

Step 7: Connect Tamper Switch (optional in fire-only systems/required for burg)

The TG-7FP provides a two-pin connector to the embedded tamper switch. Securing the cover of the enclosure presses down on the tamper switch creating an open state, removing the cover creates a closure.

Mandatory for Commercial Burg Use

When installing TG-7FP for Commercial Burglary or combination Fire and Burglary Applications, a tamper switch is used to monitor the TG-7FP enclosure opening. The tamper switch needs to be connected to a zone on the panel and shall designate the zone as Tamper Protection. All Canadian Installations shall also meet the installation requirements of CAN/ULC-S302 standard for Installation and Classification of Burglar Alarm Systems for Financial and Commercial Premises, Safes and Vaults.

Optional Use or As Required by AHJ

For all other installations, the tamper switch can be used to report unauthorized alarm system access by connecting it to a zone on the panel and designating the zone as Tamper Protection. Some local enforcing authorities may require that the tamper feature be used.

Appendix 1 – Connection Guide

Wiring Diagrams

The following wiring diagrams show the configurations in which the TG-7FP can be used:

- Sole Path (TG-7FP is the only communication path connected to the panel): *Cellular-Only transmission with Link supervision* (180-sec, 5-min, or 60-min)
- Primary or Secondary Path (another communication path is connected to the panel): *Cellular-Only transmission with self-test* (6-hr or 24-hr)

Scenario 1: Sole Path (TG-7FP is the only communication path)

Used when the communicator is working in a system that does not involve a Telco connection or a secondary path. In this case, the alarm panel is connected directly to the TG-7FP, and there is no other connection for communication. For commercial fire installations, a specific level of link supervision may be required (frequencies of 180 seconds, 5 minutes, or 60 minutes).

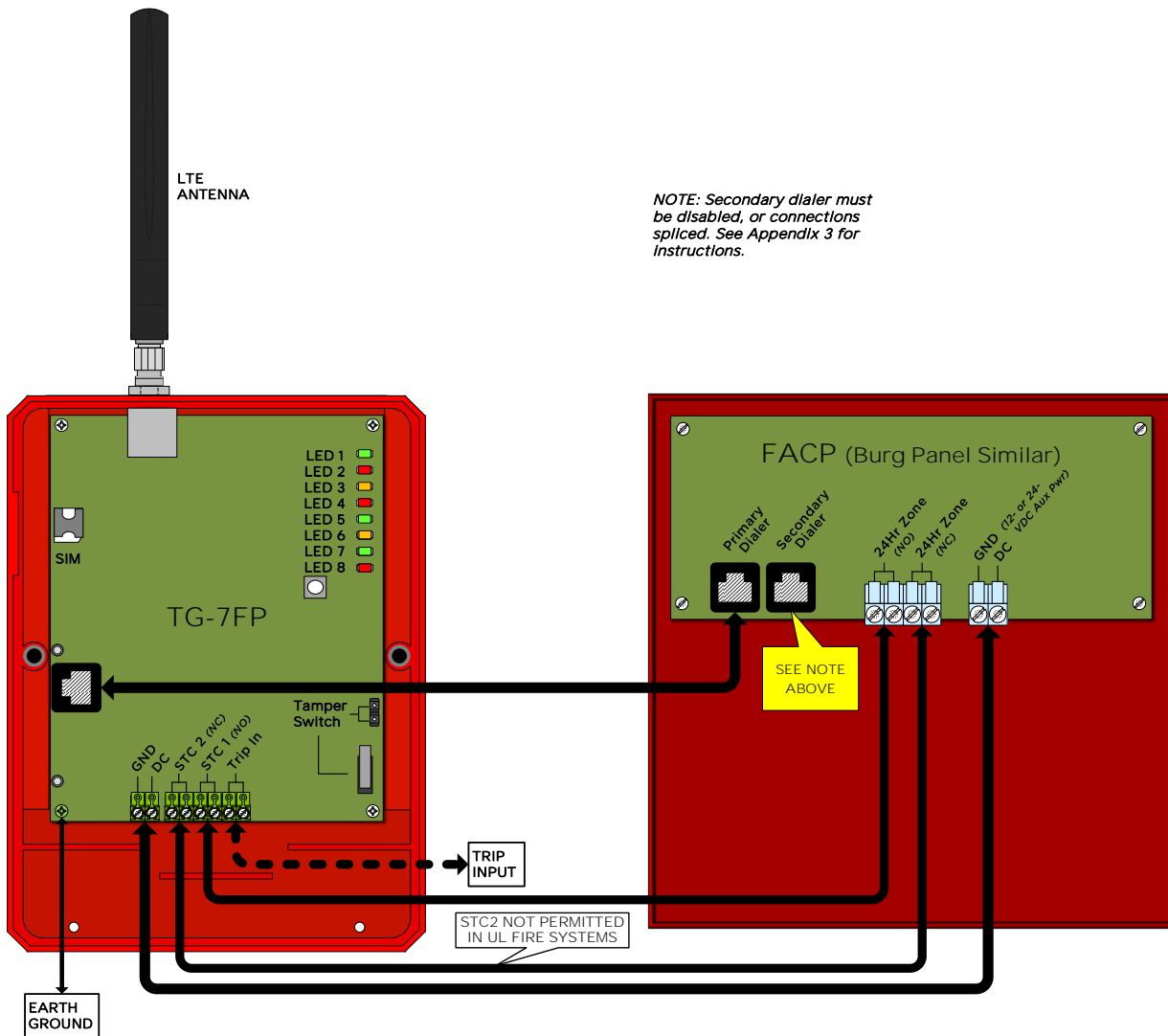

Scenario 2: Other than Sole Path (TG-7FP is one of two communication paths)

Used when the communicator is working in a system that also involves a Telco connection or another communication path. In this case, both the TG-7FP and the alternate connections are being monitored by the Alarm Panel. It is the alarm panel that determines which communication path to use for signal delivery.

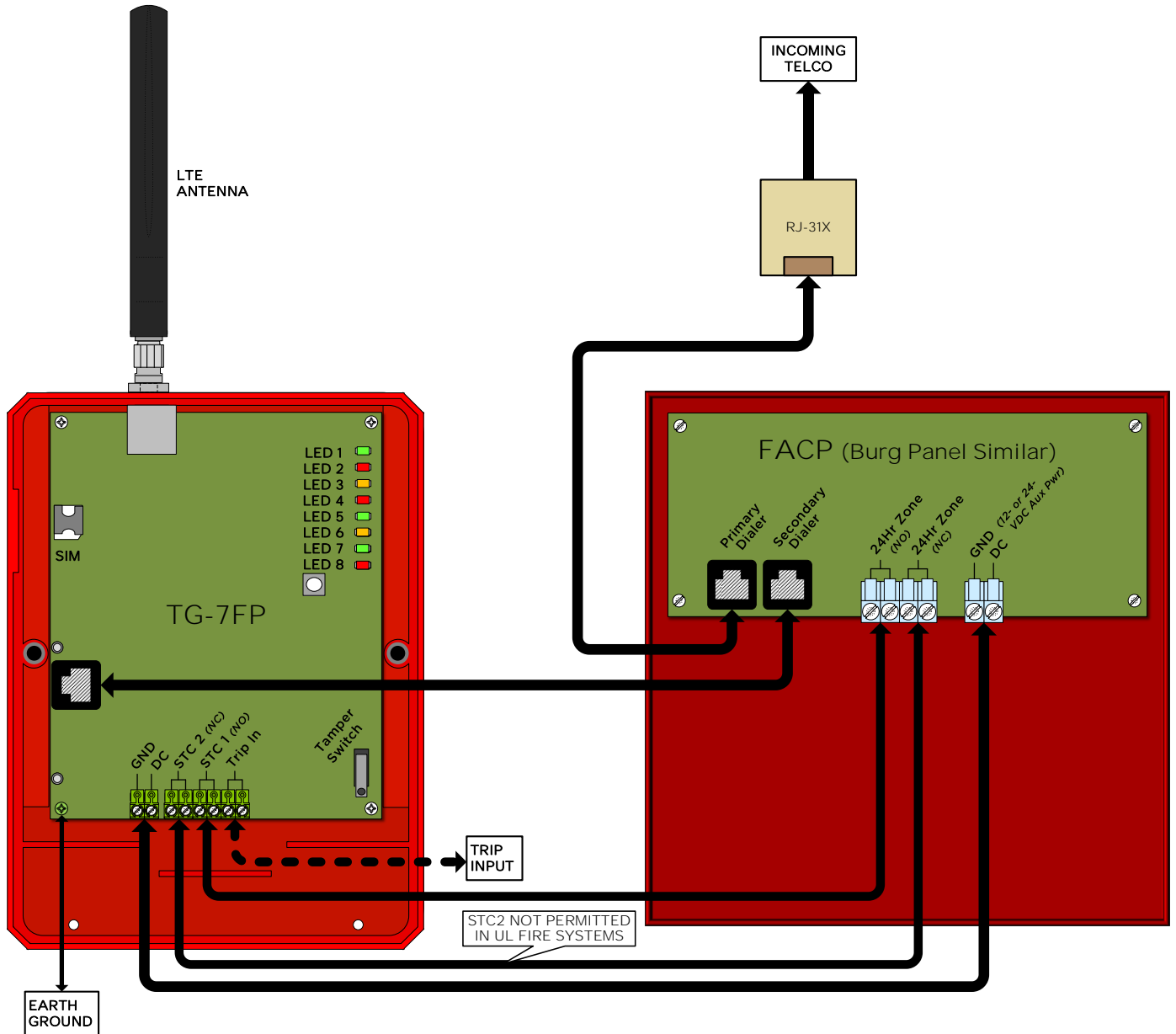

Tamper Switch Installation for UL/ULC Commercial Burglary

For all UL/ULC Commercial Burglary Installations, a Tamper switch must be wired to monitor the TG-7FP enclosure. The wiring from Tamper Switch to the panel shall be in a rigid or flexible metal conduit along with other wiring from the TG-7FP to the Panel.

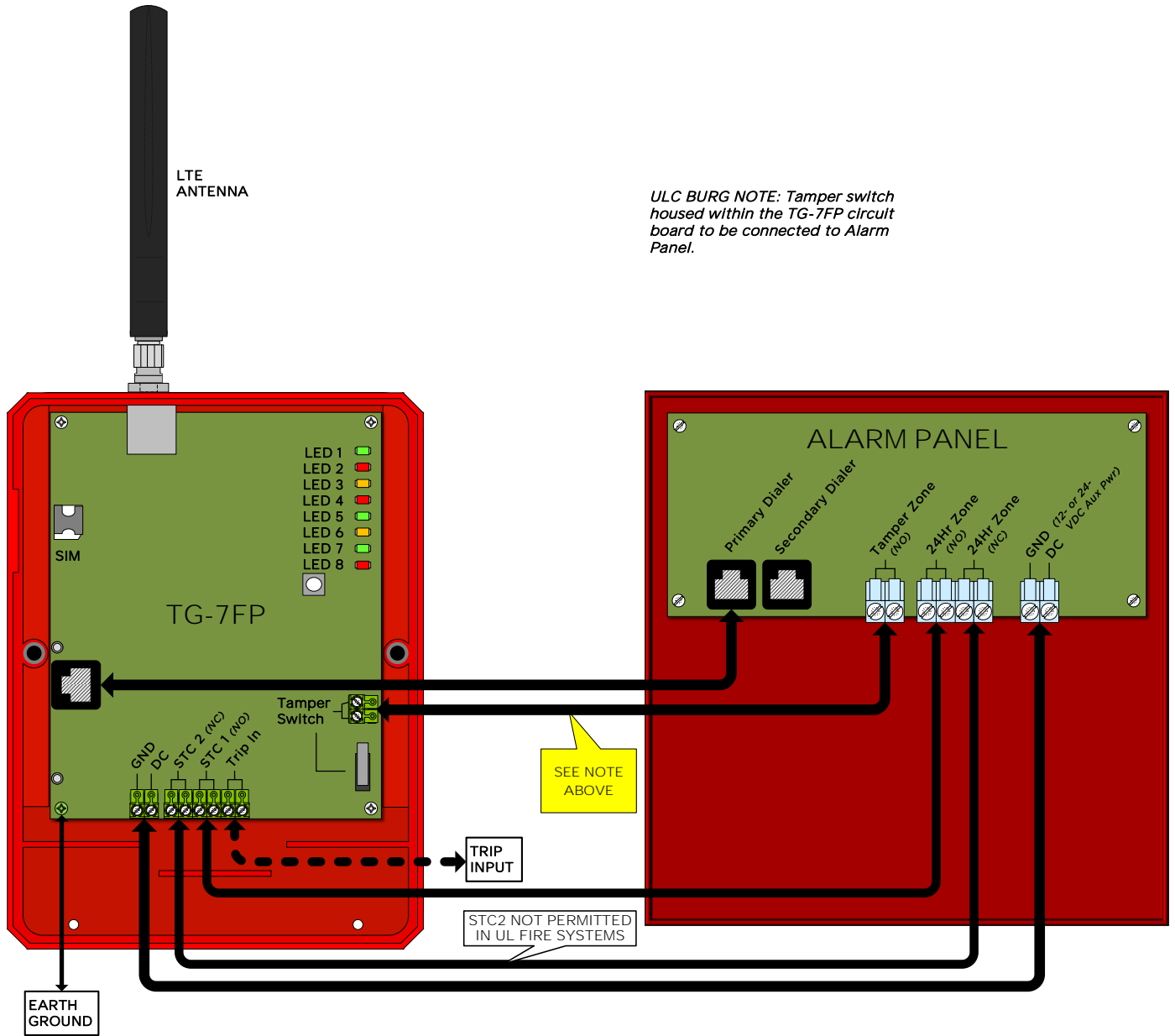

RJ-45 Jack Pin Assignments

Jack	Connects To	Pin Assignment	Function	Status LED Reference
Black	Digital Dialer input/output of host alarm panel.	1 = Brown R1 2 = Blue 4 = Green R (Ring) 5 = Red T (Tip) 7 = Orange 8 = Gray T1	Connects alarm panel to TG-7FP for transmitting alarms to central station.	If PPF is ENABLED, STC LED 2 will flash 7 times when alarm panel is not detected and PPF enabled.

DC Terminal Strip Pin Assignments

Terminal Strip Pin	Definition	Connects To	Function	Note
1 GND 2 DC	Power input	Regulated 12VDC or 24VDC Source	Powers up the communicator	Consumption rates vary based on input voltage used

Main Terminal Strip Pin Assignments

Terminal Strip Pin	Definition	Connects To	Function	Status LED Reference
1 STC2 2 STC2	Supervisory Relay Trip output for programmable trouble conditions. Normally Closed.	24-hour trip zone input on alarm panel.	Enables transmission of programmed supervisory trouble code (see diagram or installation section).	STC LED 2
3 STC1 4 STC1	Supervisory Relay Trip output for programmable trouble conditions. Normally Open.	24-hour trip zone input on alarm panel.	Enables transmission of programmed supervisory trouble code (see diagram or installation section).	STC LED 2
5 GND	Trip Ground	External trip relay.	Allows an external relay to trigger an alarm signal.	LED 7
6 IN	Trip Input	External trip relay.	Allows an external relay to trigger an alarm signal.	

Compatible Alarm Panels

Any UL/ULC/cUL Listed alarm panel that supports one of the formats listed below is compatible and may be used with the TG-7FP:

In order for the alarm panel to be compatible with the TG-7FP, the alarm panel must be programmed to transmit alarm messages to the central station using one of the following non-extended formats:

- Pulse Formats:
 - 3+1 pulse; 10pps, Double Round, 1400 Hz ack
 - 3+1 pulse; 20pps, Double Round, 2300 Hz ack
 - 3+1 pulse; 40pps, Double Round, 2300 Hz ack
 - 4+2 pulse; 20pps, Double Round, 1400 Hz ack
 - 4+2 pulse; 20pps, Double Round, 2300 Hz ack
 - 4+2 pulse; 40pps, Double Round, 2300 Hz ack
- Contact ID
- Modem IIe/IIIa²/4
- SIA2 (SIA-DC-03 level 2 release at 300 baud)
- Sonitrol
- DMP

Hexadecimal account numbers can be used with 3+1 or 4+2 formats, as well as Contact ID and Modem (4 or 10 digits for Contact ID, 4 digits for Modem).

UL Compliance Note: *While the TG-7FP supports the above formats, some formats may not meet the requirements for fire systems set in UL 864. Contact ID and SIA2 are the only formats identified as complying beginning with UL 864 10th Edition. If in doubt, check with your AHJ.*

Appendix 2 – Troubleshooting Guide

This section provides a summary of all LED indications and their meanings, as well as the expected behavior of the TG-7FP under various exception conditions.

LED Indicator Guide – Normal Operating Mode

LED Symbol	Color	Showing	Indication
LED 1 Activation	Green	Solid On	Unit is activated at the TCC and enabled
		Off	Unit not activated at TCC (and disabled)
		Flash*	Unit is disabled
LED 2 STC (System Trouble Condition)	Red	Off	ALL OK
		1 Flash*	System Trouble Condition - LPF Low Power Failure
		2 Flashes*	NOT APPLICABLE
		3 Flashes*	NOT APPLICABLE
		4 Flashes*	System Trouble Condition - NSC No Service
		5 Flashes*	System Trouble Condition - RFC Radio Failure
		6 Flashes*	System Trouble Condition - DTF Dial Tone Failure
LED 3	Yellow	Off	Alarm panel idle (Telguard on-hook)
		Flash* (1 sec)	Alarm panel off-hook to transmit signals over cellular
LED 4 Acknowledgement	Red	Solid On	TG-7FP waiting for acknowledgement from the TCC
		Off	Idle state
		Flash*	When flashing with LED 1, unit has failed activation. CALL TELGUARD TECHNICAL SUPPORT
LED 5 Radio	Green	Off	TG-7FP initialized
		On	TG-7FP initializing with cellular network
		Flash (1 sec)	Radio receiving message
		Flash (2 sec)	Radio sending message
		Flash (2x/6 sec)	Link Supervision Mode
LED 6	Not used		
LED 7 Trip Input	Green	Solid On	Trip Input activated
		Off	Trip Input not activated or is restored
LED 8 Power	Red	Solid On	DC power connected to unit

* LED will continuously flash each pattern

Troubleshooting Quick Reference Table

Telguard Event		LED Indication	Relay Output	Radio Message	Internal Action
STC * (System Trouble Conditions)	LPF	PWR LED 8 is off. STC LED 2 flashes continuously 1 time.	Optional	Optional	Verify connection from panel aux power and correct.
	NSC	STC LED 2 flashes continuously 4 times.	Optional	None	Continue to validate signal strength, NSC will restore when signal returns.
	RFC	STC LED 2 flashes continuously 5 times.	Optional	None	Wait for RFC restoration.
	DTF	STC LED 2 flashes continuously 6 times.	Yes	Yes	Internal dial tone voltage supply circuit failure.
	PPF	STC LED 2 flashes continuously 7 times.	No	Yes	Wait for PPF restoration.
Not Activated		Activation LED 1 off.	Yes	None	The communicator will not function until the first signal is sent to the TCC to activate the unit.
Automatic Self-Test		Radio LED 5 flashes during transmit.	None	Yes (Self-test)	Send Self-test information to central station via TCC, return to ready state.
Telguard Check Status		Radio LED 5 flashes during transmit.	None	Yes (Status data)	Send Status data to the TCC for review.
Telguard Enable and Configuration Update		Radio LED 5 flashes during transmit.	None	Configuration Data	The TG-7FP sends setup configuration to the TCC and switches to READY state to begin operation.
Disable TX (Initiated by TCC)		Radio LED 5 flashes when transmitting.	Yes	Yes (Status data)	TX capability is disabled until further notice. The TG-7FP can still receive radio signals from the TCC.

* If several trouble conditions are present, the STC LED will flash all applicable indications in sequence.

LED Indicator Guide – RSSI Mode

This communicator has a Received Signal Strength Indication (RSSI) Mode that works similarly to the bars on a cellular telephone. LEDs 2 through 5 will illuminate to represent the quality of the connection: the more LEDs illuminated (i.e., the higher the number of bars), the better.

To enter RSSI mode, press either of the two RSSI buttons. These buttons behave identically. The button on the circuit board is easier to access if the cover is open, while the side RSSI button can be accessed when the cover is closed. To use the side button, use the provided tool or an unbent paper clip. A simple press and release of either RSSI button will place the TG-7FP in RSSI mode and another simple press will exit RSSI mode. Note that while the RSSI button is held in, LEDs 2-5 will blink in unison once per second.

RSSI Value	LED's Lighted	RF dBm
NO SVC	LED 5 = slow flash, LEDs 4-2 = off	N/A
1	LED 5 = on, LEDs 4-2 = off	≤ -111
1½	LED 5 = on, LED 4 = slow flash, LEDs 3-2 = off	≥ -110
2	LEDs 5-4 = on, LEDs 3-2 = off	≥ -100
2½	LEDs 5-4 = on, LED 3 = slow flash, LED 2 = off	≥ -90 (Minimum recommended)
3	LEDs 5-3 = on, LED 2 = off	≥ -80
3½	LEDs 5-3 = on, LED 2 = slow flash	≥ -70
4	LEDs 5-2 = on	≥ -60

NOTE: When LED 1 is on in RSSI mode, it indicates more than one cellular tower within range.

Appendix 3 – Commercial Fire Sole Path Installation

Starting with the 2010 edition of NFPA 72, the TG-7FP can be utilized as the sole path for fire communications. By following Telguard's installation guidelines, the installer can provide the best conditions for a stable, sole path connection. In order to ensure that the cellular path to be used for signaling has the highest reliability possible, it is necessary to confirm two additional conditions, beyond what is outlined above.

TG-7FP Signal Strength

Installation instructions for the Telguard TG-7P indicate that a signal strength of -90dBm (LEDs 4 and 5 on, with LED 3 flashing) is sufficient. While this is suitable for “normal” use, an additional level of signal integrity will minimize false alarm supervision failures caused by interference and atmospheric fading. Because of this, it is always recommended that the communicator be installed in a location that provides the best signal strength possible.

Configure Alarm Panel for Sole Path

Fire panels are typically provided with two Telco connections in order to provide multiple reporting paths. With the TG-7FP having a single RJ-45 Jack, one of these Telco connections is no longer necessary for UL 864 compliance when using the TG-7FP as the sole path of communication. However, the panel will continue to supervise that unused line unless changes are made at installation time.

There are two methods for removing supervision alarms at the panel caused by disconnecting the second Telco connection. Either method can be used.

1. Disabling the Second Telco Connection

Some fire panels can be configured to disable the second Telco connection. Once the second Telco connection is disabled, the panel no longer supervises the connection. This is the preferred method of removing supervision alarms at the panel caused by removal of the second Telco connection.

2. Connecting the Telco Connections Together

The Telguard communicator is capable of providing dial tone to both Telco connections, if the Telco connections are connected together, such that “TIP” is connected to “TIP”, and “RING” is connected to “RING”. The two connections will receive dial tone in much the same way that multiple extensions in a household are connected together. If this method is used, the installer must take care to ensure that dual path reporting is not enabled on the panel, or else simultaneous alarm reports from the two Telco connections may interfere with each other.

When using this method, it is important to test the TG-7FP device thoroughly. Make sure the panel does not report a problem with the second line, especially when the panel is reporting to the central station.

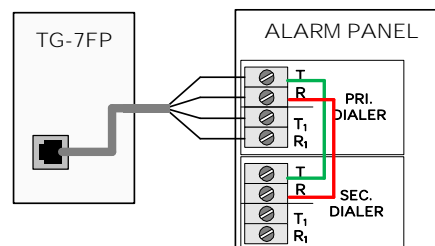

Appendix 4 – Commercial Fire 6-hour Supervision

The NFPA 72 2013 Edition updated the requirement to supervise the transmission path at least once every 6 hours, from an earlier version of 24 hours. This requirement is upheld in 2016 and 2019 edition as well. Telguard commercial fire products support this feature, and it must be enabled for each panel that uses more than one path, by selecting 6-hour supervision during registration.

Appendix 5 – Compliance with UL and ULC Standards

UL Comm Burg	UL Comm Fire	UL Comm Fire/Burg	ULC Comm Burg	ULC Comm Fire	
Yes	Optional	Yes	Optional	Optional	UL/ULC/cUL Listed Bell and Bell Housing *
Yes	Optional	Yes	Yes	Optional	Enclosure tamper Switch connected to 24-hour circuit
Yes	Yes	Yes	Yes	Yes	Antenna cable in flexible conduit concealed
No	No	No	Optional	Yes	Radio Frequency warning label placed on outside of front cover
Optional	Yes	Yes	Optional	Yes	Flexible or Rigid conduit required to protect connections #

NOTES: * Use Mercantile Listed bell and bell housing

All conductors of a fire alarm system shall be installed in metal raceway of the totally enclosed type or incorporated in a cable having a metal armour or sheath; these metal elements must be grounded

Appendix 6 – Detailed Specifications

Dialer to Interface Electronics

The integrated interface by Telguard allows digital dialers to dial into the cellular radio network.

- Line voltage: -30 Vdc (default) or -40Vdc into standard telephone device when on-hook.
- Dial tone: Precision 350 + 440Hz +/- 1%. 10 digits dial out capability.
- Mode: Loop start only. 25mA +/- 10% off-hook.

Power

Regulated Input Voltage (Power Limited)	Current Draw		
	Idle No Supervision	Idle w/Link Supervision	Max during Transmission
12VDC	20mA	40mA	201mA
24VDC	13mA	18mA	109mA

Field Wiring Electrical Ratings

STC 1 relay: 30V/120mA Max Load
STC 2 relay: 30V/100mA Max Load
Trip Input: 30V/100mA Max Load

System Faults Impedance

Trip Input: < 750 Ω considered short circuits and > 10 k Ω considered open circuits

Digital Cellular Radio and Other Specifications

The Telguard TG-7FP radio provides data connectivity on LTE-M networks. The TG-7FP transceiver is FCC compliant, meeting all requirements of Part 15 and 27 testing. It is also certified as compliant to PTCRB requirements.

- TG-7FP-A (AT&T service) Supported Bands: 2, 4, 12
- TG-7FP-V (Verizon service) Supported Bands: 4, 13
- FCC ID: N7NHL78M
- IC ID: 2417C-HL78M
- Antenna Port: TNC connector (female), 50-ohm
- RF performances are compliant with 3GPP recommendation TS 36.101
- Physical Size: 8.25 x 5.75 x 2 inches (exclusive of antenna)
- Shipping weight: 2.2 lbs.
- Operating Environment: 0° C to +49° C; 0 - 93% humidity (non-condensing)

Appendix 7 – Accessories

P/N	Description
ACD-12	12 feet of antenna cable and mounting bracket
ACD-35	35 feet of low loss high performance antenna cable and mounting bracket
ACD-50	50 feet of low loss high performance antenna cable and mounting bracket
ACD-100	100 feet of low loss high performance antenna cable and mounting bracket
HGDL-0	High Gain Directional Antenna
EXDL-0	External Omni-Directional Antenna