

SHEAR ALIGNING MAGNALOCK

1 INTRODUCTION

Securitron's Shear Aligning Magnalock "SAM2-24" is a smaller, 24 Volt (only) version of the original "SAM" Magnalock and is intended for installations where concealed mounting in the door and frame is desired. As with the original SAM, the operating features allow self-alignment while securing the door when it closes. The SAM2 is designed to operate with one-way swing, bi-directional swing or sliding type doors. On swing type doors the lock installs horizontally in the top or bottom of the door frame or may be installed vertically in the door frame side. For slider type door applications the lock must be installed horizontally for proper operation. These units have also been designed to unlock even if a preload is applied to the door.

2 SPECIFICATIONS

MODEL	SAM2-24
Holding Force	600 Lbs [272kg]
Dimensions: Length	7.2" [183mm]
Height	1.15" [29mm]
Depth	0.94" [24mm]
Voltage	24 Volts DC
Current @ 24 VDC	84mA

3 PRODUCT OVERVIEW

Upon unpacking this product, an inventory should be made to ensure that all the required components and hardware have been included. Along with these instructions and the installation template, each product should include the following items:

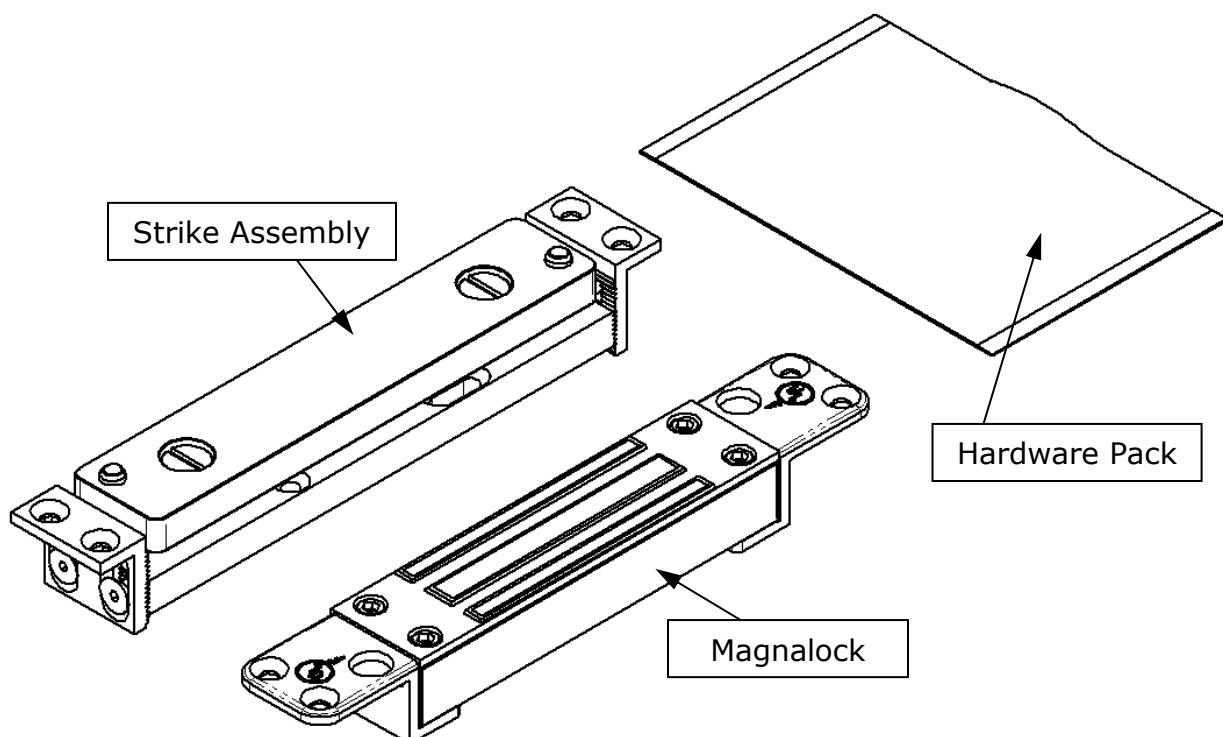
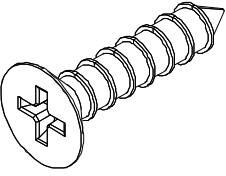
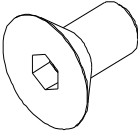
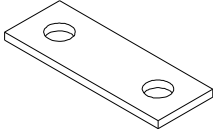
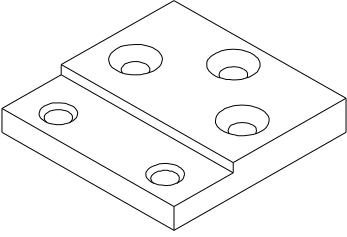
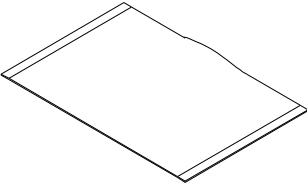
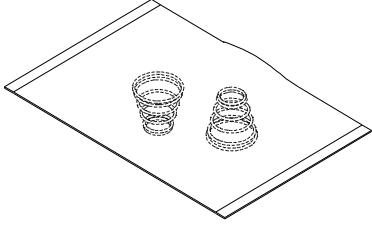

Figure 1 – SAM2-24 Magnalock

3.1 HARDWARE

10X		20X		8X	
					
Phillips Flat Head #8 X 3/4" Type "A"		Socket Flat Head 8-32 X 1/2"		Shim Plate	
4X		1X		1X	
					
Flush Mount Bracket		Thread Locking Compound Pack		Floor Install Replacement Spring Pack (2 Springs)	

4 RECOMMENDED TOOLS

- | | |
|--|---|
| Router or Saber Saw | Measuring Instrument (Ruler/Tape Measure) |
| Hammer | Masking Tape |
| Chisel | Fish Tape or Lead Wire |
| Center Punch | Wire Strippers/Cutter |
| Power Drill | Crimp Wire Connectors |
| 7/64", 9/64", 3/16" & 5/16" Drill Bits | Crimp Tool |
| 3/8" Diameter X 82° Countersink Bit | Multimeter |
| Phillips and Standard Screwdrivers | |

5 INSTALLATION INSTRUCTIONS

5.1 Pre-Installation Survey

It is recommended that an initial on sight survey be performed. A method of mounting should be determined and an installation plan should be reviewed as follows:

- Physical strength of mounting areas should be strong enough to meet or exceed the holding force of the required Magnalock.
- Placement of the Magnalock wiring and protection from potential damage due to intruders or vandals external attack should be considered during the survey.
- Accessibility should be considered for prevention of any potential safety hazard.

The door and frame areas additionally need to be examined for mortising capabilities, sufficient size and should be free of any internal obstructions. The top-of-door installation is recommended as the most suitable location for protection from impact attacks.

NOTE: THE SAM2-24 STRIKE ASSEMBLY IS NOT RECOMMENDED FOR USE IN ALUMINUM OR STEEL FRAMED DOORS THAT HAVE A CHANNEL RECESS AT THE TOP. FOR PROPER OPERATION IN HOLLOW METAL DOORS THE STRIKE ASSEMBLY SHOULD BE MOUNTED IN THE FLUSH MOUNT ARRANGEMENT ONLY!

5.2 Swinging Door

The illustrations in **Figure 2** demonstrate a SAM2 installed in a swinging door. This is a common configuration where the Magnalock is recessed into the door frame header near the corner opposite the hinge side and the strike assembly is flush mounted into the top edge of the door. The Magnalock may be mounted horizontally or vertically depending on the installation required. The flush mount brackets shown are inserted into hollow metal door and frame to provide a recessed installation.

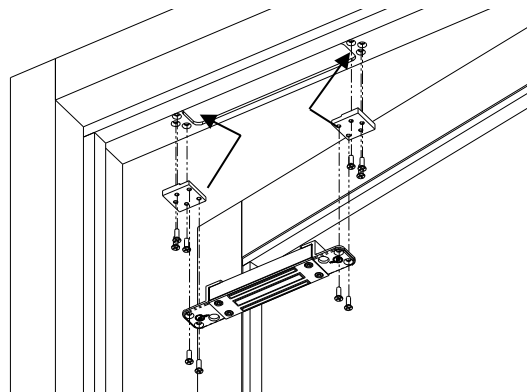

Magnalock mounted in door frame

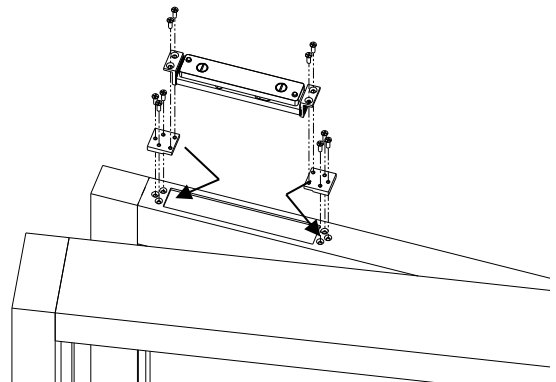

Strike mounted in edge of hollow metal door

Figure 2 - Swinging door configuration

5.3 Sliding Door

The illustrations in **Figure 3** demonstrate a SAM2 installed in a sliding door. The Magnalock mounts recessed into the door frame header and the strike assembly is mounted into the top edge of the sliding door.

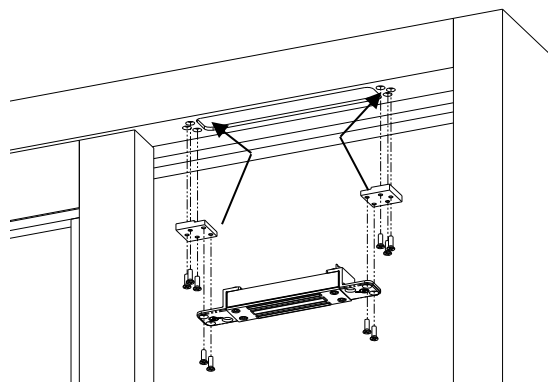

Magnalock mounted in door frame

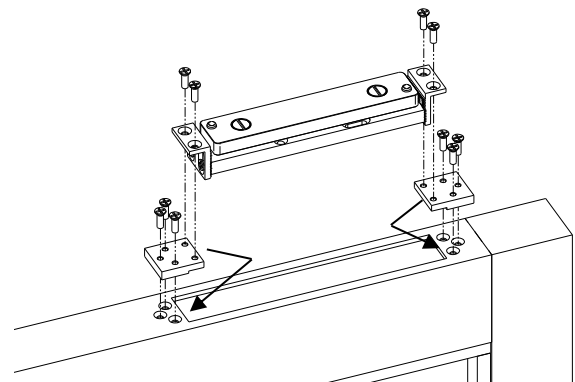

Strike mounted in edge of door

Figure 3 - Sliding door mounting configuration

5.4 Frame and Door Preparation

5.4.1 Frame Preparation

Select a mounting location for the Magnalock and strike assembly as mentioned in **Section 5.1**. The following general guideline should be used for consideration during the installation review:

- **Read and follow the directions on the template provided which includes drilling and mounting instructions.**
- An approximated 2" [51mm] clearance distance should be allowed between the Magnalock (mounting bracket) and the inside corner of the door frame. This will provide adequate access for the mounting locations and for drilling and tool access.

ALWAYS CHECK THE STRIKE MOUNTING AREA IN THE EDGE OF THE DOOR FOR OBSTACLES WHEN DETERMINING WHERE TO LOCATE THE MAGNALOCK. MAKE CERTAIN THAT THE STRIKE MOUNTING AREA DOES NOT HAVE ANY OBSTRUCTIONS (I.E. DOOR ADJUSTMENT SCREWS OR DOOR CLOSER OPERATORS) THAT MIGHT HINDER INSTALLATION - BEFORE CUTTING OR DRILLING ANY HOLES.

- Locate and mark the desired lateral centerline position for the Magnalock/strike assembly on the face of the door. Using this door mark as reference, mark the same lateral center location of the Magnalock onto the door frame.
- Setting the depth center position of the Magnalock is more critical because there is not a lot of free depth in the door frame or door to accommodate any centering error. To locate the centerline in the door frame:

- For a one-way swing door: Make sure the door is closed completely and measure the distance between the face of the door and the frame stop (usually about 1/8"). Open the door and measure the thickness of the door. Divide the thickness of the door in half (this will be the center of door) and add the distance measured between the door and stop. Measure the total distance out from the face of the stop and mark the centerline for the Magnalock.
- For a bi-directional swing door: Ensure the door is in the centered at-rest position. (A door closer may require adjustment). Using a pencil, trace the inside and outside edges of the door onto the frame. Measure half the distance between these two marked door silhouette lines and mark the centerline for the Magnalock.
- Using the Magnalock mounting information in **Section 5.5** and the template provided, align the appropriate template into position on the frame and mark the mortise cutout area.
- Using a router or saber saw, or chisel (for wood) cut out the area for the Magnalock mounting. Insert the Magnalock into the frame and mark the bracket locations for the mounting holes.
- Using the drill size information on the template and a power drill, bore the holes required.

5.4.2 Door Preparation

NOTE: THE SAM2-24 STRIKE ASSEMBLY IS NOT RECOMMENDED FOR USE IN ALUMINUM OR STEEL FRAMED DOORS THAT HAVE A CHANNEL RECESS AT THE TOP. FOR PROPER OPERATION IN HOLLOW METAL DOORS THE STRIKE ASSEMBLY SHOULD BE MOUNTED IN THE FLUSH MOUNT ARRANGEMENT ONLY!

- Locate the previously marked lateral centerline position for the strike assembly on the face of the door.
- Open the door and measure the total depth distance (thickness) of the door. Divide this distance in half to locate the depth centerline of the strike assembly.
- Using the strike assembly mounting information in **Section 5.6** and the strike template provided, center the template into position on the door and mark the mortise cutout area.
- Using a router, saber saw or chisel (for wood) cut out the area for the strike assembly mounting. Insert the strike assembly into the door and mark the bracket locations for the mounting holes.
- Using the drill size information on the template and a power drill, bore the holes required.

IF MOUNTING THE STRIKE AT THE BOTTOM OF THE DOOR (FLOOR MOUNT) IS CHOSEN, THE TWO (2) IDLE PLATE SPRINGS IN THE STRIKE ASSEMBLY NEED TO BE REPLACED WITH THE ALTERNATE SET OF IDLE SPRINGS PROVIDED IN THE HARDWARE PACK.

5.5 Mounting the Magnalock

The desired cable exit location should be determined prior to installing the Magnalock. The Magnalock is symmetrical which allows the cable exit from either end into the door frame. There are many different techniques for mounting the Magnalock depending on the type or style of doors and frames. The following sections describe installation methods for use on hollow aluminum, steel and wood type doors and frames.

5.5.1 Hollow Metal Door Frames

Prepare the door frame in accordance with **Section 5.4.1**.

Place the Magnalock into the cutout area to ensure proper fit. As necessary, perform any filing or cutting necessary to ensure the mortised fit. Ensure all necessary holes required to mount the Magnalock and flush mount brackets into place as indicated on the template have been provided. Install the Magnalock using a screwdriver, the listed mounting screws and the flush mount brackets as shown in **Figures 4** and **5** below.

The adaptation to variation in frame material thicknesses can be obtained by flipping the orientation of the flush mount brackets. Shim plates are also provided which may be used in conjunction with the flush mount brackets to create the desired exposed height of the Magnalock and/or to compensate for the various material thicknesses of door frames.

It is recommended that the **Magnalock face protrude approximately 1/16" [1.6mm]** beyond the surface of the frame. Both **Figures 4** and **5** show a shim plate between the lock mounting bracket and the flush mount bracket in order to raise the Magnalock above the frame surface.

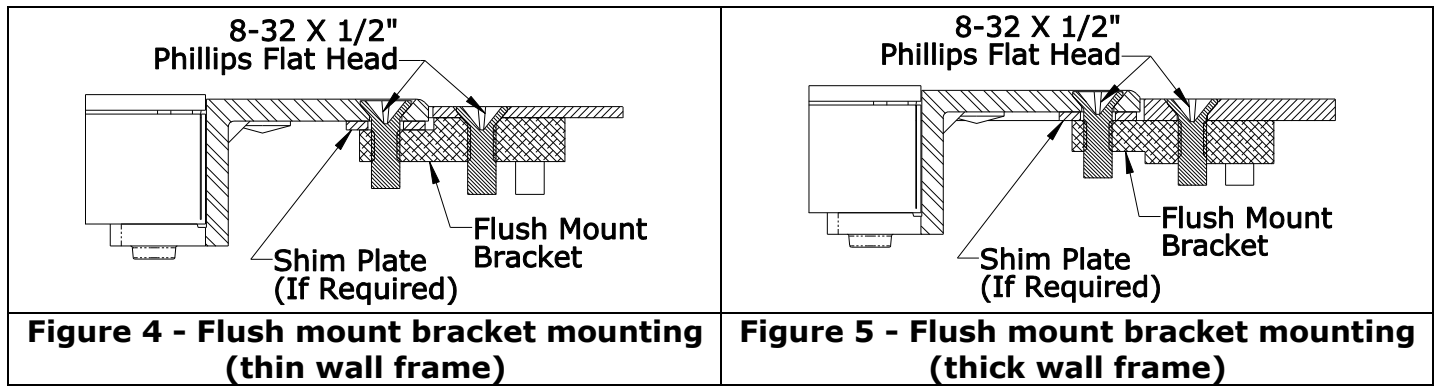

APPLY THE PROVIDED THREAD LOCKING COMPOUND TO ALL MOUNTING SCREW THREADS.

5.5.2 Solid Wood Door Frames

Prepare the door frame in accordance with **Section 5.4.1**.

Place the Magnalock into the cutout area to ensure proper fit. As necessary, perform any filing or chiseling necessary to ensure the mortised fit. Ensure all necessary holes required to mount the Magnalock into place as indicated on the template have been provided. The depth of the mortise cutout is important for proper fit. The minimum depth of the cutout is noted in **Figure 6** below and includes enough distance for the required recess depth of 1/16" [1.6mm] of the mounting brackets. Install the Magnalock using the wood mounting screws as shown in **Figure 6**.

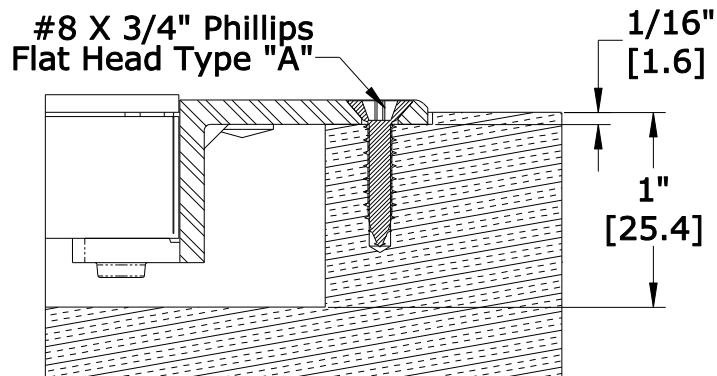

Figure 6 - Wood frame lock bracket mounting

5.6 Mounting the Strike Assembly

The strike assembly mounting method varies with the type of door being used. The included template provides preparation and installation information for the various types of doors. The following sections describe the door type and installation procedures.

The strike bracket assembly has been designed with adjustment features which are intended to help accurately install and adjust the strike assembly for proper operation. The two L-shaped end brackets and the idle bracket of the assembly are serrated to provide a secure locking adjustment of the height of the strike in the door edge. The end brackets have obround slots to limit the adjustment travel and to support the structure of the assembly. By loosening the screws at each end, the brackets can be adjusted to the desired mounting height.

The serrations on the brackets are .050" [1.3mm] apart which matches the screw thread pitch distance that mounts the strike. This feature will be explained during the final adjustment in **Section 5.7**. These end brackets may also be inverted to provide for deeper mounting configurations. See **Figure 7** and **Figure 8** for adjustable ranges and mounting methods.

THE POSITION OF THE CENTERLINE OF THE STRIKE ASSEMBLY IS CRITICALLY RELATED TO THE CENTERLINE OF THE MAGNALOCK LOCATION.

5.6.1 Hollow Metal Door (Flush Top)

NOTE: THE SAM2-24 STRIKE ASSEMBLY IS NOT RECOMMENDED FOR USE IN ALUMINUM OR STEEL FRAMED DOORS THAT HAVE A CHANNEL RECESS AT THE TOP. FOR PROPER OPERATION IN HOLLOW METAL DOORS THE STRIKE ASSEMBLY SHOULD BE MOUNTED IN THE FLUSH MOUNT ARRANGEMENT ONLY!

Prepare the door in accordance with **Section 5.4.2**.

Mounting the strike assembly into a door with flush outside surfaces utilizes the same methods as mounting the Magnalock into a hollow metal type frame. **Figure 7** below shows a typical installation in a flush type aluminum door. In this process the flush mount brackets are used to suspend the strike assembly into the door. Make the necessary adjustments to the end brackets of the strike assembly to set the initial strike height in the door installation. The flush mount brackets may be installed in either direction (see **Figures 4** and **5**) to set the appropriate flush mounting condition, and the provided shim plates may also be used to assist in further adjustment of the installation. Use a screwdriver and the provided mounting screws to complete the installation.

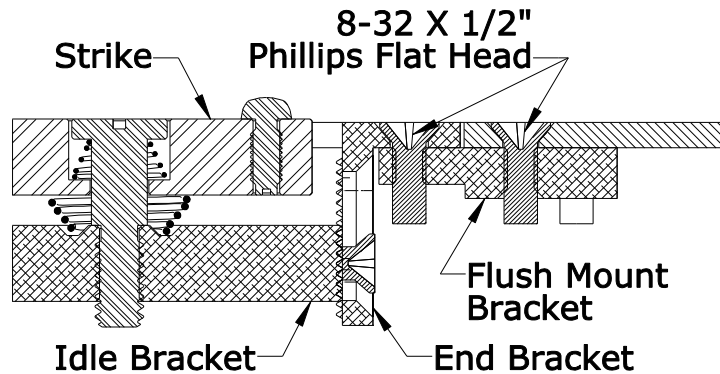

Figure 7 - Hollow frame strike assembly mounting

APPLY THE PROVIDED THREAD LOCKING COMPOUND TO ALL MOUNTING SCREW THREADS.

5.6.2 Hard Core Wood Door

Prepare the door in accordance with **Section 5.4.2**.

For mounting into hard core (solid) wood doors the strike assembly may be mounted with or without the end brackets attached. The door cutout requires a mortise area for the strike base assembly with sizes that are dependent on whether the end brackets are used or not (see template). The depth requirements are illustrated in **Figures 8** and **9**. If the installation does not require use of the end brackets (as shown in **Figure 8**), the installer must be accurate on the depth of the cutout. (If the mortised cutout is too shallow it will not allow enough room for the strike to be adjusted down any lower and the door operation may be hindered. If the cutout is too deep, shimming may be necessary to adjust the idle bracket height in the installation). When the end brackets are used, the cutout area requires a minimum depth (shown in **Figure 9**) and because of the adjustability in the end brackets, cutting the recess too deep will not affect the installation.

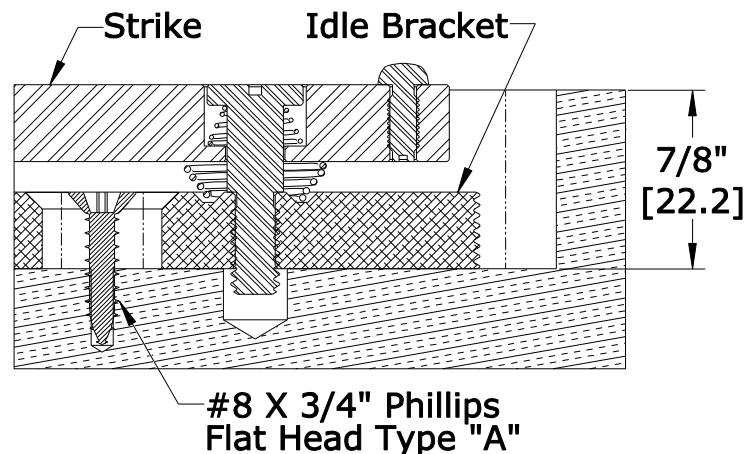

Figure 8 - Wood door strike mounting without brackets

5.6.3 Soft Core Wood Door

Use of the end brackets is recommended when installing the strike assembly on soft core wood style doors because a "pocketed" soft core door is not as strong in supporting the lateral forces applied to the strike assembly. Use of the end brackets will provide a much more sound and secure anchoring platform for the installation. Refer to **Section 5.6** for use and adjustment of the end brackets. **Figure 9** illustrates the dimensional requirements of the cutout necessary for installation into wood doors using the strike end brackets.

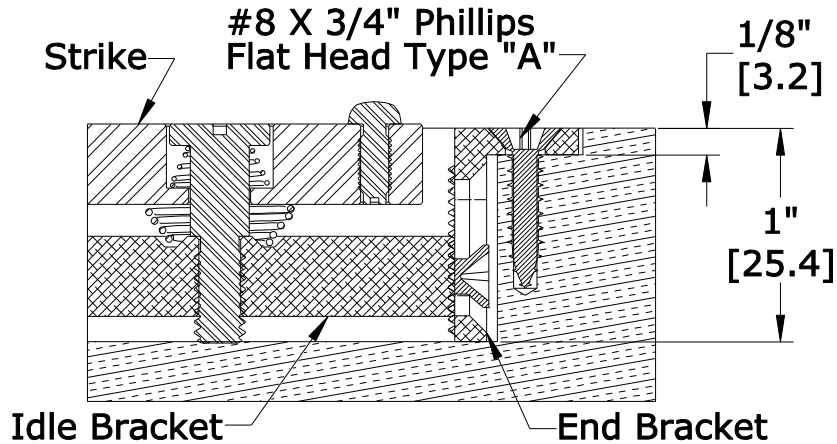

Figure 9 - Wood door strike mounting with brackets

5.7 Strike Assembly Final Adjustments

5.7.1 Strike Level Adjustment (De-energized)

De-energized adjustment of the strike height is important for proper door/lock operations. The example in **Figure 10** illustrates the Magnalock with the proper adjustment. Without power applied to the Magnalock, both of the (conical) interference buttons should just clear the lock brackets. Check this by opening and closing the door. To adjust the clearance to be closer, turn each of the strike adjustment (shoulder) screws (located in the center of the strike) counter-clockwise 1/4 turn, one at a time and recheck the clearances. (Both screws do not have to be adjusted the same amount of turns). The adjustments should be made independently so that the strike level is uniform to the door frame and Magnalock installation. **The strike screws are allowed up to two (2) full turns of adjustment each.** If the adjustment required is two (2) full turns or greater, then tighten the screws clockwise back to the down position, loosen the end bracket screws and adjust the end brackets the amount of notches necessary to enable the final adjustments. Repeat adjustments as necessary until a properly functioning gap setting is achieved.

THE INITIAL SETTING OF THE STRIKE ADJUSTMENT (SHOULDER) SCREWS SHOULD BE NO MORE THAN TWO (2) TURNS OUT. THIS WILL ALLOW A LARGER ADJUSTMENT RANGE TO ACCOMMODATE POTENTIAL FUTURE DOOR SAG.

THE CONICAL INTERFERENCE BUTTONS ON THE STRIKE PLATE SHOULD JUST CLEAR THE LOCK BRACKET SURFACES TO INSURE THE CORRECT GAP.

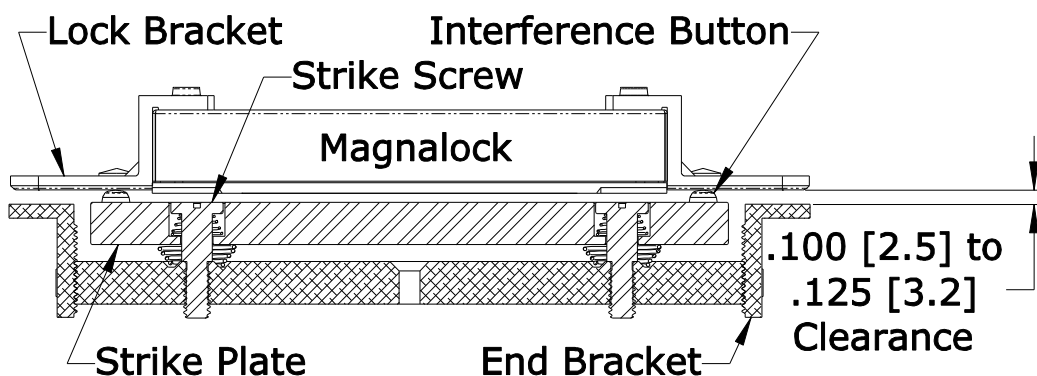

Figure 10 - Magnalock and strike assembly (side view)

5.7.2 Strike Level Adjustment Testing (Energized)

Energized adjustment testing of the strike height is important for proper door/lock operations. This adjustment should be performed after the de-energized adjustment, outlined in **Section 5.7.1**. With the door closed and the Magnalock de-energized, apply power to the Magnalock. The strike should be pulled up against the Magnalock face. De-energize the Magnalock and the strike should return to the previously adjusted height. This function should be tested several times to insure that the strike level adjustment is correct.

If the strike is not pulled up to the face of the Magnalock, the strike is too far away from the Magnalock. Make small 1/4 turn adjustments to the strike screws until the correct level and clearances are obtained for proper function.

A second test should be performed with the door starting from the opened position. Apply power to the Magnalock and then close the door under normal operations. The strike should be attracted to the Magnalock, but the strike and the interference buttons should pass completely into the locking position to secure the door. Test this operation several times to ensure consistent operation of the Magnalock/strike installation.

WHEN THE MAGNALOCK IS ENERGIZED FOR A CONTINUOUS DUTY MODE, THE ADJUSTMENTS MADE MAKE IT A POSITIVE LOCKING MODE FOR CONTROLLED ACCESS. IF THE MAGNALOCK IS SET FOR CONTINUOUS DUTY, THE EXIT REQUEST ALLOWS THE STRIKE TO DROP AWAY AND CLEAR FOR SMOOTH EGRESS. WHEN THE MAGNALOCK BECOMES ENERGIZED, WHILE THE DOOR IS STILL IN THE OPENED POSITION, THE DOOR CLOSING AND LOCKING FEATURES WILL STILL FUNCTION, WHEN THE DOOR CLOSURES, THE STRIKE REALIGNS BACK TO THE LOCKING POSITION TO SECURE. THERE SHOULD BE NO INTERFERENCES THAT PREVENT THE DOOR FROM CLOSING OR BECOMING SECURE.

6 ELECTRICAL INSTALLATION

6.1 General Characteristics

The Magnalock is a low current load device using specialized internal circuitry. The normal characteristic of an inductive load, such as inductive kick-back, is not present. See **Section 2** for more information.

6.2 Electrical Standards

DC voltage, full-wave rectified, must be provided for proper operation of the Magnalock. The red wire receives +24VDC, and the black wire, 0 Volts (negative). If the Magnalock is connected with reverse polarity, it will not operate. The SAM2-24 Magnalock is a single voltage (24VDC only) device.

6.3 Poor Release Characteristics

The SAM2 Magnalock is designed with quick release operation. Wiring errors may cause a Magnalock to release slowly. **Figure 11** illustrates a parallel installation of a resistive load (correct). **Figure 12** illustrates a parallel reverse diode (incorrect).

SLOW RELEASE PREVENTION (WIRING CONSIDERATION)

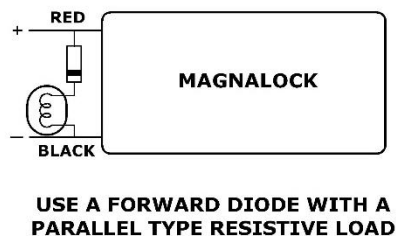

Figure 11

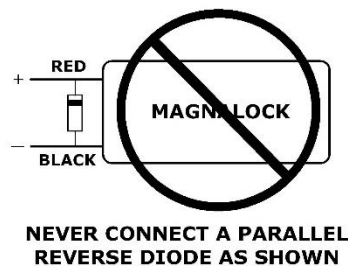

Figure 12

6.4 Electrical Wiring

The following diagram, **Figure 13**, represents the proper electrical wiring connections required for the SAM2-24 Magnalock.

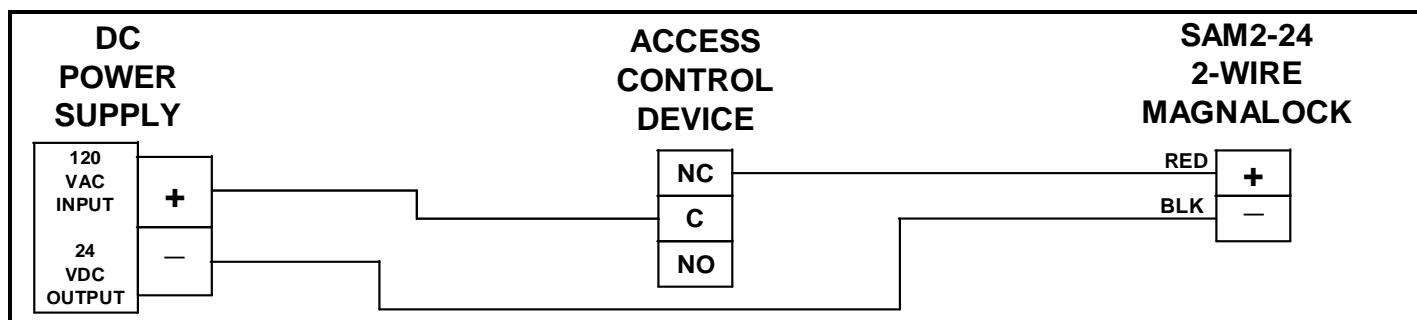

Figure 13

6.5 Emergency Release

Magnalocks are often wired into a system for quick release in case of emergency. Manual switching or automatic triggering from a fire alarm system is practical. It is the user's responsibility to correctly hookup the Magnalock according to the instructions. It is recommended to use a switch or relay to perform break of power. Securitron power supplies have terminals for the interconnection of such emergency release switches.

THE END USER AND INSTALLER ARE LIABLE FOR ALL FIRE AND BUILDING CODE COMPLIANCE.

7 MAGNALOCK MAINTENANCE

7.1 Visual Inspection

- Check the strike assembly for proper gap, suspension and free movement. Tighten strike adjustment screws as required.
- Check for build-up of debris on the Magnalock and strike armature. Clean as required.
- Check for rust on the Magnalock and strike assembly. Clean as required.

7.2 Cleaning Methods

- Cleaning once a year is recommended.
- Clean every six months where minor rusting occurs.
- Clean every three months if rust conditions are severe.
- Use a plastic dishwashing scrub pad to aid in the removal of rust.

**DO NOT USE PETROLEUM BASED PRODUCTS FOR CLEANING
DO NOT USE STEEL WOOL BASED SCRUB PAD OR SANDPAPER**

7.2.1 Indoor Applications

- Apply rubbing alcohol onto a clean cloth and thoroughly wipe down the Magnalock and strike plate armature.

7.2.2 Outdoor Applications

- Apply a silicone based cleaner/lubricant onto a clean cloth and thoroughly wipe down Magnalock and strike plate armature.

Example: Super Lube® Aerosol with SYNCOLON® (PTFE)
Part No.: 31040 ~ 6oz. / 31110 ~ 11 oz. / 32015 ~ 14 oz.
Phone: (631) 567-5300 / Website: www.super-lube.com

APPENDIX A

Troubleshooting

Problem	Lock Does Not Generate a Magnetic Field	Points of Reference
Solution	Check for specified voltage at Magnalock	Section 2
	Check for specified current draw at Magnalock	Section 2
Problem	Reduced Holding Force	Points of Reference
Solution	Check DC power source is Full-Wave Rectified (Half-wave Rectifier or AC Power unacceptable)	Section 6.2
	Check for specified voltage at Magnalock	Section 2
	Check for specified current draw at Magnalock	Section 2
	Check strike mounting for proper installation	Sections 5.6-5.7
	Check the Magnalock and strike for obstructions and that contact surfaces are properly cleaned	Section 7
Problem	The Magnalock Does Not Release	Points of Reference
Solution	Make sure no voltage is present at Magnalock	Section 2
	Make sure the Magnalock is not drawing current	Section 2
	Check if the strike is sticky and hard to release	Section 7
	Check the Magnalock and strike for obstructions and that contact surfaces are properly cleaned	Section 7
Problem	The Magnalock is Dirty or Rusty	Points of Reference
Solution	Improper cleaning – Maintenance Equipment	Section 7
Problem	Electronic Noise Interference with Access Control System	Points of Reference
Solution	Check for voltage from Magnalock to door frame. There should be no voltage present.	Section 2

**IF PROBLEMS PERSIST CALL SECURITRON TOLL FREE
(800) 626-7590**

APPENDIX B

Wire Gauge Factoring

1. Remote Power Supply

- The Magnalock requires adequate voltage and current for proper operation.
- Resistance is created by the length and gauge (size) of the wire being used.
- An accurate estimated distance from the power supply to the opening is crucial.
- For superior operation the correct size gauge wire must be used.
- The devices used operate the best with the least amount of resistance on the source.
- Using the correct gauge wires protects against large voltage and current (load) losses.
- The gauge is determined by the wire distance, voltage and current of all devices.

2. Determining Wire Gauge

The general practice of wire sizing in a DC circuit is to avoid causing voltage drops in connecting wires that reduce the voltage available to operate the device. As Magnalocks are very low power devices, they can be operated long distances from their power source. For any job that includes long wire runs, the installer must be able to calculate the correct gauge of wire to avoid excessive voltage drops.

This is done by taking the current draw of the lock and multiplying by the resistance of the wire $I \times R = \text{Voltage drop}$ (i.e. $0.100A \times 10.1 \text{ Ohms} = 1.01 \text{ Volts}$ dropped across the wire). For all intents and purposes it can be said that a 5% drop in voltage is acceptable so if this were a 24 Volt system ($24 \text{ Volts} \times .05 = 1.2 \text{ Volts}$) a 1.01 Volt drop would be within tolerance.

To calculate the wire resistance, you need to know the distance from the power supply to the Magnalock and the gauge (thickness) of the wire. The following chart shows wire resistance per 1000 ft (305 meters):

Wire Gauge	Resistance/1,000 ft	Wire Gauge	Resistance/1,000 ft
8 Gauge	.6 Ohms	16 Gauge	4.1 Ohms
10 Gauge	1.0 Ohms	18 Gauge	6.4 Ohms
12 Gauge	1.6 Ohms	20 Gauge	10.1 Ohms
14 Gauge	2.5 Ohms	22 Gauge	16.0 Ohms

MAGNACARE® LIFETIME REPLACEMENT WARRANTY

For warranty information visit:

assaabloyesh.com/en/local/assaabloyeshcom/about/warranty/

PATENTS

Patent pending and/or patent

www.assaabloydss.com/patents