

SNE SERIES DIGITAL SECURITY NETWORK ENCLOSURE

Configured specifically to address the needs of hybrid security systems consisting of a mix of analog and digital equipment and cabling



FEATURES

- Fully welded construction provides the following weight capacities:
 - UL Listed load capacity – 3,000 lbs.
 - Caster load capacity – 1,600 lbs.
 - Seismic certified capacity – 1,050 lbs.
- Configured for front to rear, or front to chimney passive cooling depending on model
- Ships fully configured, and includes
 - 70% open area vented front door
 - Solid or split 70% open area rear doors
 - Chimney (select models only)
 - Pair of split flush mount locking side panels
 - Set of Lever Lock™ mounting brackets
 - Casters
 - Leveling feet
- Available in 24", 27.6" and 30" widths
- 36", 42" and 48" overall depths
- Includes 2 pairs of cage nut fully adjustable rackrail and 6MM mounting hardware
- Doors accommodate industry standard electronic door locks



shown with chimney

SNE SERIES DIGITAL SECURITY NETWORK ENCLOSURE

OPTIONS

- Split lift-off cable chase shall be 4.4" wide and mount in-between enclosures, model # SNE-CC-__LT (refer to drawing for model number)
- Cable duct shall be model # SNE-__DUCT-4X6-__ and be available packaged or installed (refer to chart)
- Cable chase shall be model # SNE-__-CC12-45__ (refer to chart), and shall be 12" wide x __" deep x 83.33" high
- Front air dam/zero-U panel mount shall be model # SNE-__-FAD-PM-__ (refer to drawing for model #)
- Bracket for top cable pass-through enclosure to enclosure shall provide the ability to pass cables from enclosure to enclosure when ganged together, and shall be model number SNE-TCB-__ (36, 42, 48)
- 6" wide wire type vertical lace shall be model number LACE-WB6-__ (24, 42, 45)
- Seismic Zone-4 and Seismic Use Group III compliancy floor anchor kit shall be model # SNE __-Z4 (24,27,30)
- SNE Universal Power Bracket shall be model number SNE-UVPB-4245-S and fit 42RU and 45RU models

SPECIFICATIONS

EIA compliant 19" gangable digital security network enclosure shall be Middle Atlantic Products model #SNE__D-__-P_ (refer to chart). Overall dimensions shall be __"H x __"W x __"D (refer to chart). Useable height shall be __ rackspaces, useable depth shall be __" (refer to chart). Fully welded construction shall provide a UL Listed load capacity of 3,000 lbs., and casters shall provide a capacity of 1,600 lbs. SNE shall come equipped with two pairs of fully adjustable steel cage nut rackrail with 6MM mounting hardware in universal EIA spacing, black e-coat finish and numbered rackspaces. SNE shall include 70% vented front door, __ rear doors (refer to chart), and flush locking split side panels. SNE shall include pair of Lever Lock™ mounting brackets. SNE shall have pre-threaded 5/16"-18 ganging holes. SNE shall be capable of ganging while fully loaded, using bolts only. SNE shall have passive cooling, front to rear. SNE shall have marked rackrail depth indicators. SNE shall be of fully welded construction. SNE shall be finished in an environmentally friendly, durable black powder coat. SNE Series enclosures shall satisfy the 2007 & 2010 CBC; 2006, 2009 & 2012 IBC; ASCE 7-05 (2005 Edition) & ASCE 7-10 (2010 Edition) and the 2006 & 2009 editions of NFPA 5000 for use in areas of high seismicity, Seismic Use Group III, Zone 4 or Seismic Design Category (SDC) "D" with lateral force requirements for protecting 1,050 lbs. of essential equipment in locations with the highest level of seismicity and top floor or rooftop installations with an Importance factor (Ip) of 1.5 when used with SNE-Z4 seismic floor anchor bracket. SNE shall be UL Listed in the US and Canada to the UL-2416 (NWIN) category. SNE shall be GREENGUARD Gold Certified. SNE shall be manufactured by an ISO 9001 and ISO 14001 registered company. SNE enclosure shall be warranted to be free from defects in material or workmanship under normal use and conditions for the lifetime of the rack.



SNE SERIES DIGITAL SECURITY NETWORK ENCLOSURE

BASIC DIMENSIONS

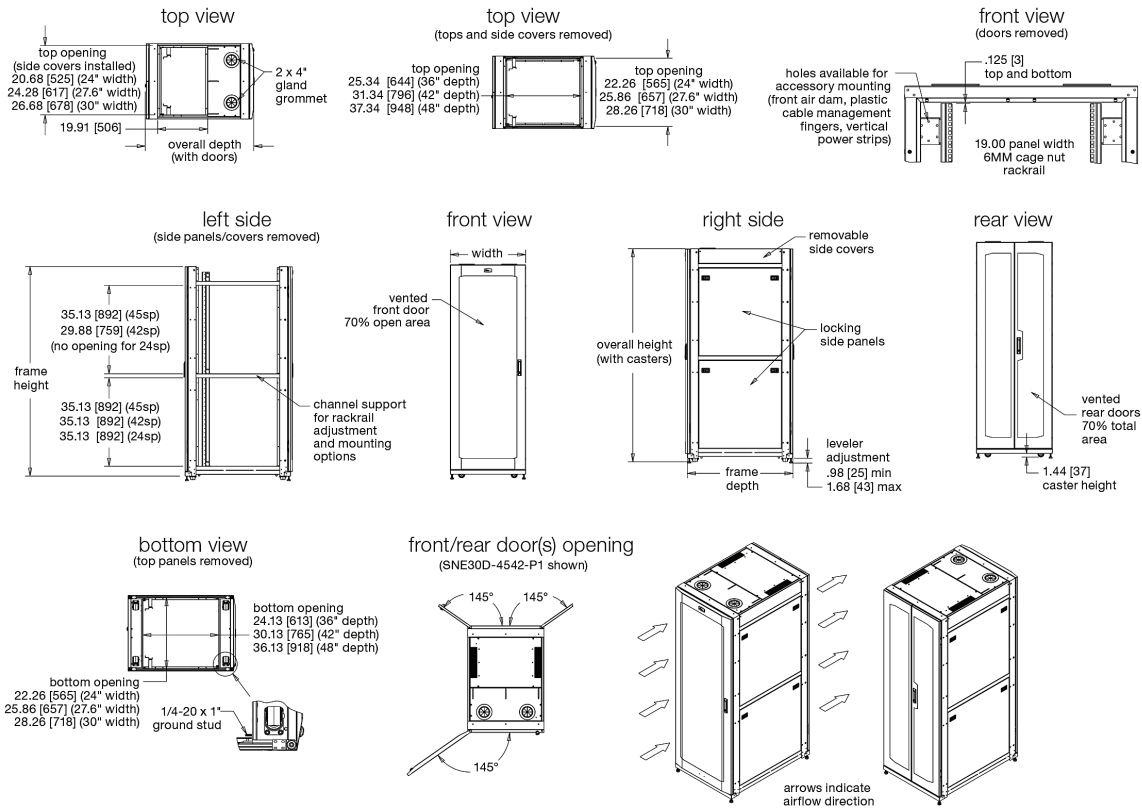

Note: Front door, rear door, and side panels are keyed the same

Overall Height (w/ casters)	Frame Height	24.00 [609] width			27.60 [701] width			30.00 [762] width			Vented Doors & Solid Top	Solid Rear Doors w/ Chimney
		36.0 [914] depth	42.0 [1067] depth	48.0 [1219] depth	36.0 [914] depth	42.0 [1067] depth	48.0 [1219] depth	36.0 [914] depth	42.0 [1067] depth	48.0 [1219] depth		
24 space 48.02 [1220]	46.58 [1183]	SNE24D-2436-P1	SNE24D-2442-P1	-	-	-	-	-	-	-	yes	no
42 space 79.52 [2020]	78.08 [1983]	SNE24D-4236-P1	SNE24D-4242-P1	SNE24D-4248-P1	SNE27D-4236-P1	SNE27D-4242-P1	SNE27D-4248-P1	SNE30D-4236-P1	SNE30D-4242-P1	SNE30D-4248-P1	yes	no
45 space 84.77 [2153]	83.33 [2117]	SNE24D-4536-P1	SNE24D-4542-P1	SNE24D-4548-P1	SNE27D-4536-P1	SNE27D-4542-P1	SNE27D-4548-P1	SNE30D-4536-P1	SNE30D-4542-P1	SNE30D-4548-P1	yes	no

Frame Depth	Useable Depth	Overall Depth (with doors)
36.00 [914]	32.48 [825]	37.15 [944]
42.00 [1067]	38.48 [977]	43.15 [1096]
48.00 [1219]	44.48 [1130]	49.15 [1248]

SNE SERIES DIGITAL SECURITY NETWORK ENCLOSURE

BASIC DIMENSIONS

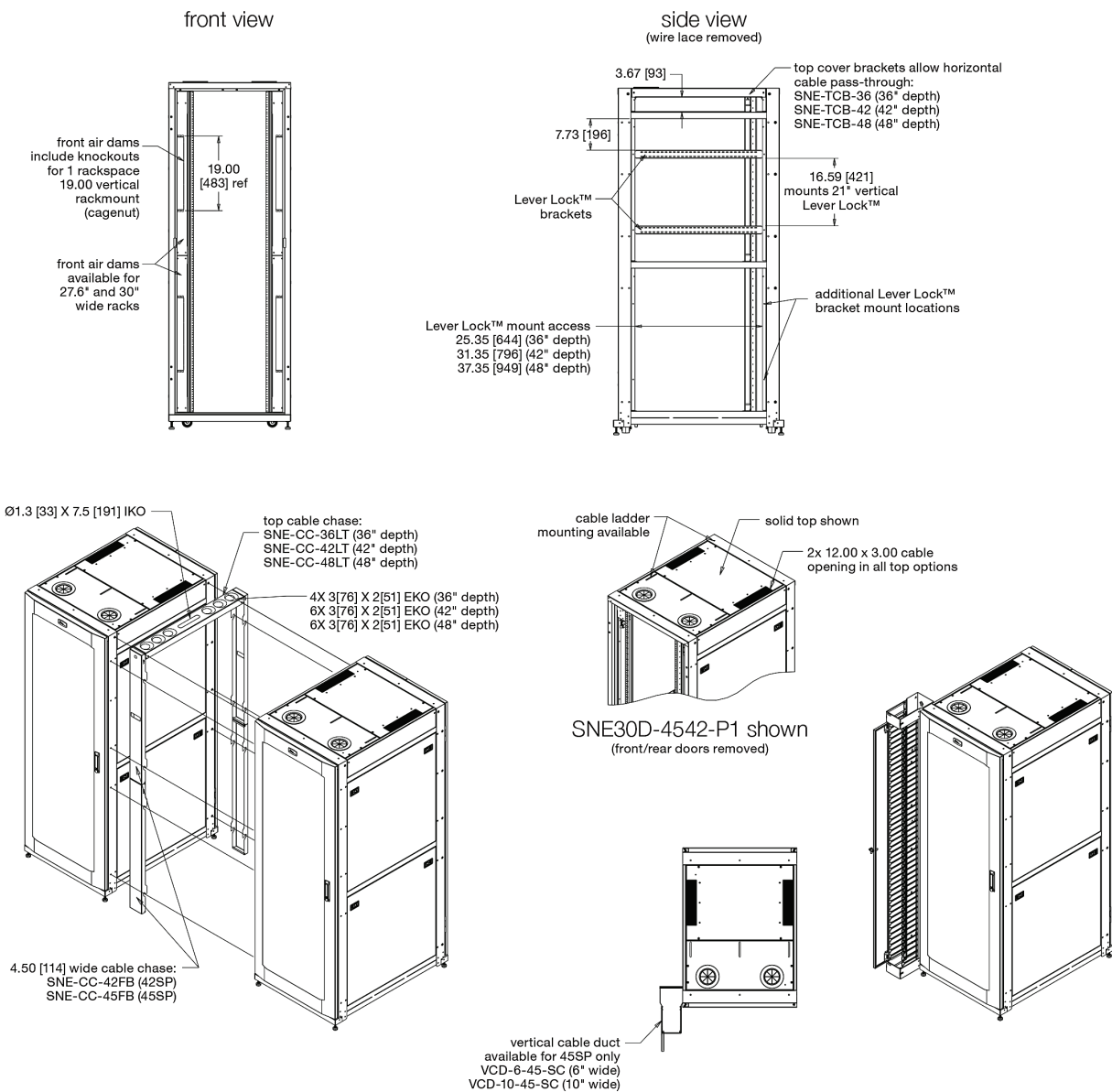

SNE SERIES DIGITAL SECURITY NETWORK ENCLOSURE

BASIC DIMENSIONS

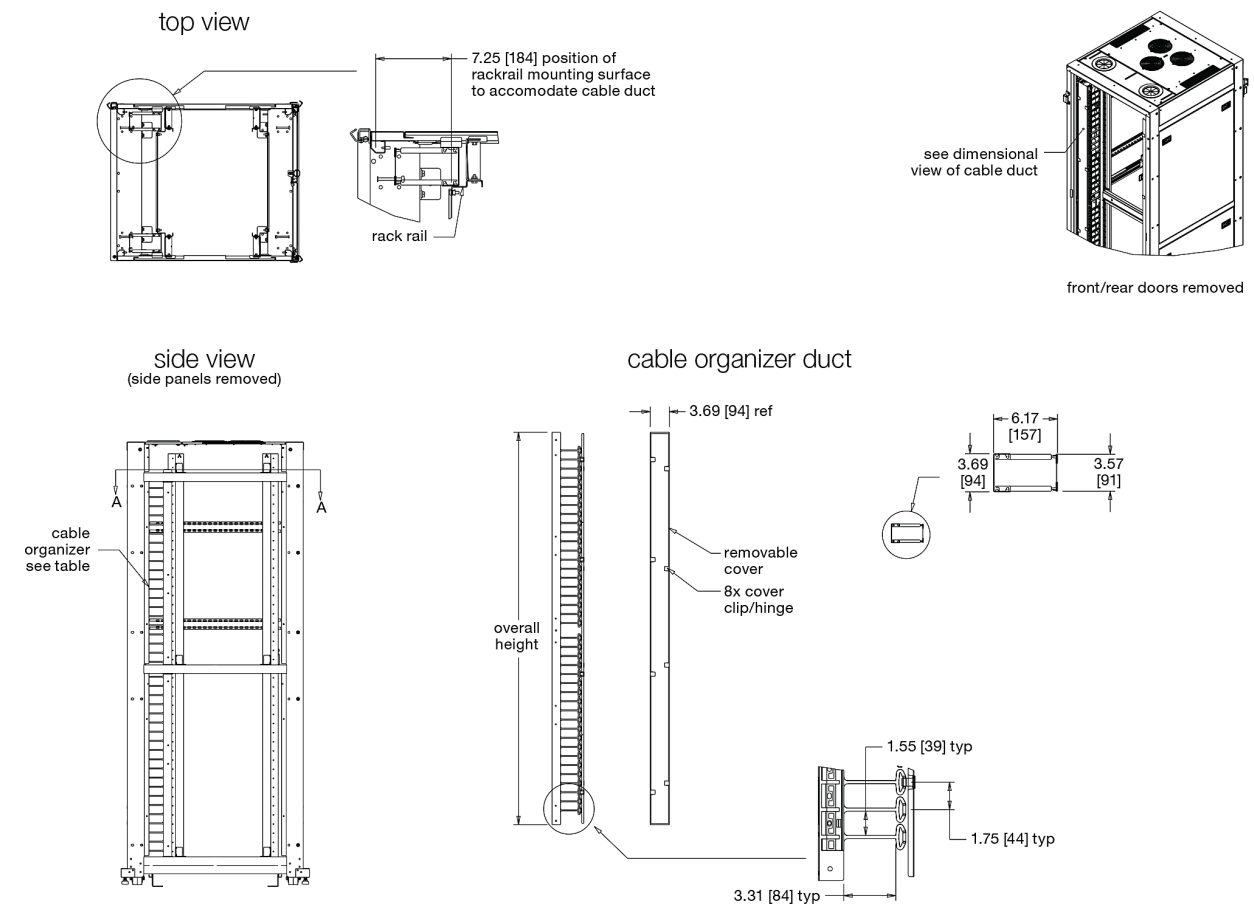

Notes:

1. cable duct can be installed at each inside corner of the rack.
3. cable ducts are only available for 30" wide racks

Cable Duct Part Number	Overall Height	Rackspaces
SNE-42DUCT-4X6	70.50 [1791]	42 space
SNE-45DUCT-4X6	75.75 [1924]	45 space

SNE SERIES DIGITAL SECURITY NETWORK ENCLOSURE

BASIC DIMENSIONS

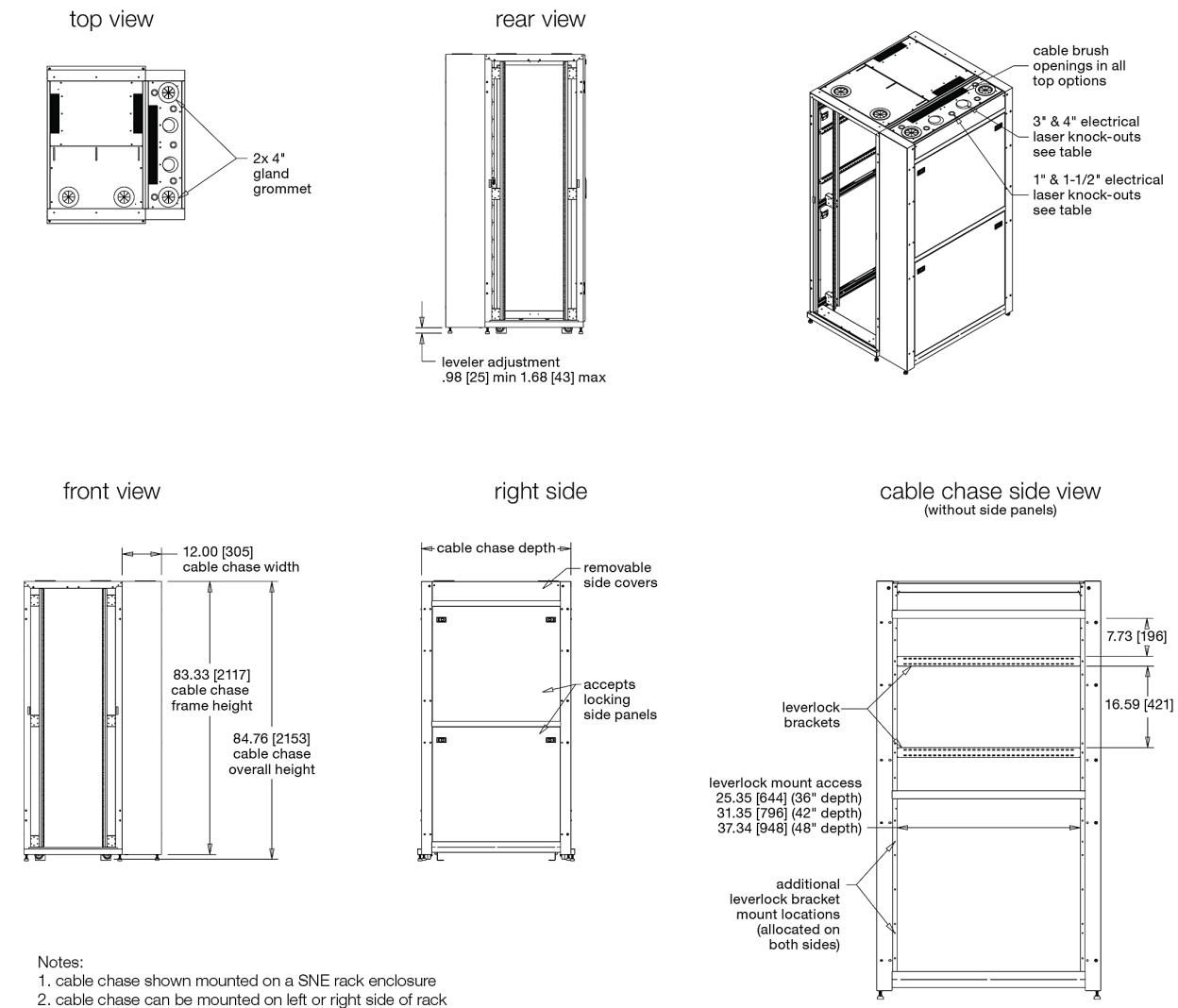

Cable Chase Part Number	Cable Chase Depth	1" & 1-1/2" LKO (Qty)	4" & 5" LKO (Qty)	Fits SNE Racks
SNE-CCE12-4536	36.00 [914]	4	1	SNEXX-4536-XX
SNE-CCE12-4542	42.00 [1067]	4	1	SNEXX-4542-XX
SNE-CCE12-4548	48.00 [1219]	5	2	SNEXX-4548-XX

SNE SERIES DIGITAL SECURITY NETWORK ENCLOSURE

BASIC DIMENSIONS

NOTES:

1. ALL DIMENSIONS SHOWN IN FORMAT: INCHES [MILLIMETERS]
2. LACE DESIGNED FOR BUTTON STYLE MOUNTING POWER STRIPS
3. FITS SNE SERIES (42U & 45U)
4. HOLES AND SQUARE HOLES ALLOWS FOR MOUNTING OF MAP VERTICAL POWER STRIPS. (PD, PDT,RLNK-V)

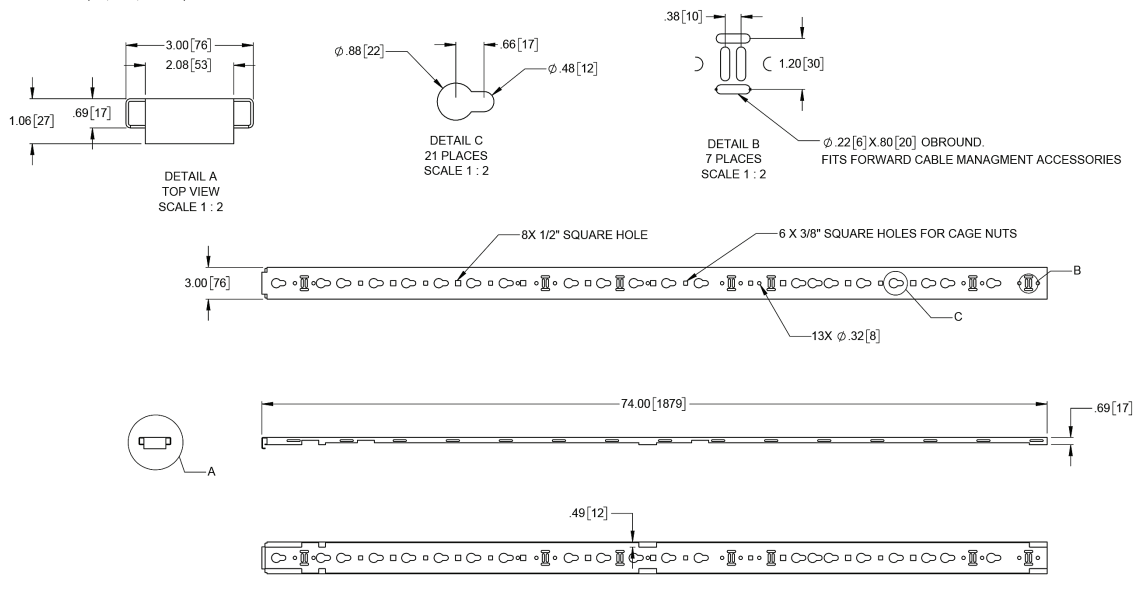

LEGRAND | AV COMMERCIAL BRANDS

C2G | Chief | Da-Lite | Luxul | Middle Atlantic | Vaddio | Wiremold

WHAT GREAT SYSTEMS ARE BUILT ON™ | legrandav.com

USA 800.266.7225 av.middleatlantic.support@legrand.com CANADA 888.766.9770 av.middleatlantic.support@legrand.com

©2022 Legrand AV Inc. 220005 Rev A 01/22 Middle Atlantic is a registered trademark of Legrand AV Inc. All other brand names or marks are used for identification purposes and are trademarks of their respective owners. All patents are protected under existing designations. Other patents pending.