

# About This Manual

This Setup Guide explains the safety precautions for using of this unit, how to install the unit, and the initial setup.

## Step 1

**Preparing ..... Page 38**

## Step 2

**Connecting ..... Page 40**

## Step 3

**Projecting ..... Page 43**

---

**Indicators ..... Page 46**

**Maintenance ..... Page 48**

**Notes on Installing the Ceiling Bracket ..... Page 51**

**Dimensions ..... Page 52**

### Manuals supplied

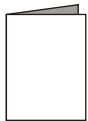

#### **Setup Guide (this document)**

Explains the safety precautions, installation method, and initial setup for this unit.



#### **Help Guide (Web operating instructions)**

Explains the features of the unit and how to use in detail. You can view the Help Guide on a smartphone or computer.

<https://rd1.sony.net/help/vpl/phz51/en/>



Before operating the unit, please read this manual thoroughly and retain it for future reference.

When using the product, do not use it for purposes other than those described in the instruction manual.

## **WARNING**

**To reduce the risk of fire or electric shock, do not expose this apparatus to rain or moisture. To avoid electrical shock, do not open the cabinet. Refer servicing to qualified personnel only.**

### **WARNING**

**This apparatus must be earthed.**

### **CAUTION**

- Danger of explosion if battery is incorrectly replaced. Replace only with the same or equivalent type recommended by the manufacturer.
- When you dispose of the battery or the product, you must obey the law in the corresponding area or country. Do not dispose of the battery or the product in a fire or a hot oven, or mechanically crush or cut the battery. It may explode or cause a fire. Do not subject the battery to extremely low air pressure that may result in an explosion or the leakage of flammable liquid or gas.
- Do not place the battery in a high temperature place, such as under direct sunlight or near fire. It may ignite, explode, or cause a fire. Do not immerse or wet the battery in water or seawater. This may cause an electric shock.

### **WARNING**

When installing the unit, incorporate a readily accessible disconnect device in the fixed wiring, or connect the power plug to an easily accessible socket-outlet near the unit. If a fault should occur during operation of the unit, operate the disconnect device to switch the power supply off, or disconnect the power plug.

### **CAUTION**

For safety, do not connect the connector for peripheral device wiring that might have excessive voltage to the following port:

- LAN

### **WARNING**

1. Use the approved Power Cord (3-core mains lead) / Appliance Connector / Plug with earthing-contacts that conforms to the safety regulations of each country/region if applicable.
2. Use the Power Cord (3-core mains lead) / Appliance Connector / Plug conforming to the proper ratings (Voltage, Ampere).

If you have questions on the use of the above Power Cord / Appliance Connector / Plug, please consult a qualified service personnel.

### **IMPORTANT**

The nameplate is located in the following location on the unit.

- Bottom

### **For the customers in the U.S.A.**

This equipment has been tested and found to comply with the limits for a Class A digital device, pursuant to part 15 of the FCC Rules. These limits are designed to provide reasonable protection against harmful interference when the equipment is operated in a commercial environment. This equipment generates, uses and can radiate radio frequency energy and, if not installed and used in accordance with the instruction manual, may cause harmful interference to radio communications. Operation of this equipment in a residential area is likely to cause harmful interference in which case the user will be required to correct the interference at his own expense.

You are cautioned that any changes or modifications not expressly approved in this manual could void your authority to operate this equipment.

All interface cables used to connect the equipment to peripherals must be shielded type to comply with EMC standard(s) and to prevent undesired operation due to radiated emissions. When cables are supplied, always use them for this purpose.

If you have any questions about this product, you may call:

Sony Customer Information Service Center 1-800-222-7669 or <http://www.sony.com/>

### Supplier's Declaration of Conformity

Trade Name : SONY  
Model : VPL-PHZ61/VPL-PHZ51  
Responsible party : Sony Electronics Inc.  
Address : 16535 Via Esprillo, San Diego, CA 92127 U.S.A.  
Telephone Number : 858-942-2230

This device complies with part 15 of the FCC Rules. Operation is subject to the following two conditions: (1) This device may not cause harmful interference, and (2) this device must accept any interference received, including interference that may cause undesired operation.

### For the customers in Canada

CAN ICES-003(A)/NMB-003(A)

### WARNING

Operation of this equipment in a residential environment could cause radio interference.

### For the customers in Europe

This apparatus shall not be used in the residential area.

### WARNING



Do not ingest battery, Chemical Burn Hazard

– The following accessory supplied with this product contains a coin/button battery. If the coin/button cell battery is swallowed, it can cause severe internal burns in just 2 hours and can lead to death.

Remote Commander

- Keep new and used batteries away from children.
- If the battery compartment does not close securely, stop using the product and keep it away from children.
- If you think batteries might have been swallowed or placed inside any part of the body, seek immediate medical attention.



This symbol is intended to alert the user to the presence of important operating and maintenance (servicing) instructions in the literature accompanying the appliance.



**IEC 60825-1:2014**  
**CLASS 1 LASER PRODUCT**

- This product complies with EN60825-1:2014+A11:2021.
- This product complies with EN50689:2021.
- This product is designed to project images on a wall or screen.

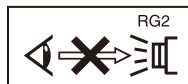

As with any bright light source, do not stare into the beam, RG2 IEC 62471-5:2015.

### CAUTION

Do not look into the lens while in use.

### Caution

Use of controls or adjustments or performance of procedures other than those specified herein may result in hazardous radiation exposure.

### Caution

The use of optical instruments with this product will increase eye hazard.

### CAUTION

Never allow children to stare into the projector beam at any distance from the projector.

### CAUTION

Do not turn on the projector with the remote commander while in front of the projection lens.

### CAUTION

Avoid the use of optical aids such as binoculars or telescopes inside the beam.

이 기기는 업무용 환경에서 사용할 목적으로 적합성평가를 받은 기기로서 가정용 환경에서 사용하는 경우 전파간섭의 우려가 있습니다.

### For kundene i Norge

Dette utstyret kan kobles til et IT-strømfordelingssystem.

### For the State of California, USA only

Perchlorate Material – special handling may apply,  
See  
[www.dtsc.ca.gov/hazardouswaste/perchlorate](http://www.dtsc.ca.gov/hazardouswaste/perchlorate)

### Türkiye'deki müşteriler için AEEE Yönetmeliğine Uygundur

#### For the customers in the U.S.A.

**SONY LIMITED WARRANTY** - Please visit <http://www.sony.com/psa/warranty> for important information and complete terms and conditions of Sony's limited warranty applicable to this product.

#### For the customers in Canada

**SONY LIMITED WARRANTY** - Please visit <http://www.sonybiz.ca/pro/lang/en/ca/article/resources-warranty> for important information and complete terms and conditions of Sony's limited warranty applicable to this product.

#### For the customers in Europe

Sony Professional Solutions Europe - Standard Warranty and Exceptions on Standard Warranty. Please visit <https://pro.sony/support-services/primessupport/support-professional-solutions-europe-standard-product-warranty> for important information and complete terms and conditions.

#### For the customers in Korea

**SONY LIMITED WARRANTY** - Please visit <http://bpeng.sony.co.kr/handler/BPAS-Start> for important information and complete terms and conditions of Sony's limited warranty applicable to this product.

## Location information of the labels

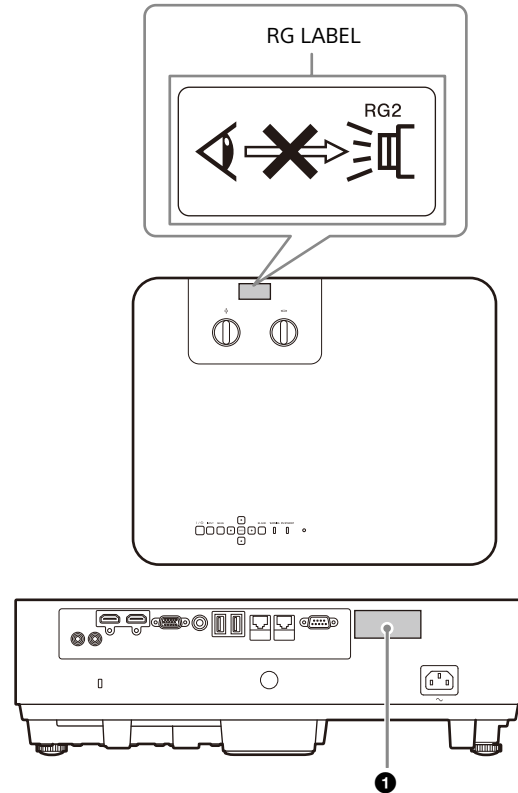

### 1 CLASS 1 LABEL

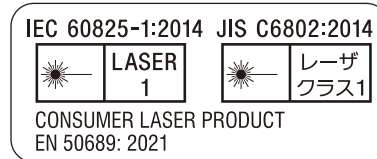

## Light source specifications

5.5 W laser diodes  
× 24 (VPL-PHZ61)  
× 18 (VPL-PHZ51)  
Wavelength: 449 - 461 nm

## Beam divergence angle from lens of this unit

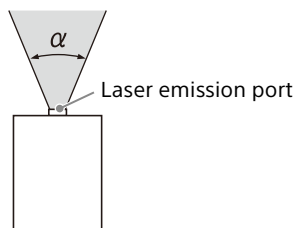

Zoom maximum: $\alpha$	Zoom minimum: $\alpha$
67.6°	45°

## Precautions

### On safety

- Check that the operating voltage of your unit is identical with the voltage of your local power supply. If voltage adaptation is required, consult with qualified Sony personnel.
- Should any liquid or solid object fall into the cabinet, unplug the unit and have it checked by qualified Sony personnel before operating it further.
- Unplug the unit from the wall outlet if it is not to be used for several days.
- To disconnect the cord, pull it out by the plug. Never pull the cord itself.
- Never use a damaged AC power cord. A damaged AC power cord can cause a short-circuit, which may result in a fire or electric shock.
- The wall outlet should be near the unit and easily accessible.
- The unit is not disconnected from the AC power source (mains) as long as it is connected to the wall outlet, even if the unit itself has been turned off.
- Do not look into the lens while in use.
- When turning on the projector, make sure no one is peeking at the projection lens.
- Do not let children use the unit alone.
- Do not place your hand or objects near the ventilation holes — the air coming out is hot.
- Be careful not to catch your fingers by the feet (adjustable) when you adjust the height of the unit. Do not push hard on the top of the unit with the adjuster out.
- Avoid using an extension cord with a low voltage limited since it may cause the short-circuit and physical incidents.
- Do not catch your finger between the unit and surface of the floor when moving the projector installed on the floor.
- Be careful not to catch your finger in the cooling fan.
- Do not install the unit in a location near heat sources such as radiators or air ducts, or in a place subject to direct sunlight, excessive dust or humidity, mechanical vibration or shock.
- If a user disassembles, repairs, or alters the unit, it may cause a serious problem to the user's safety.
- If the projector malfunctions or is damaged, consult with a qualified Sony personnel.

- If the ventilation holes are blocked, internal heat builds up, and it may cause a fire or damage the unit. To allow adequate air circulation and prevent internal heat build-up, follow the items below:
- Place the unit, leaving sufficient space from walls or any objects (page 33).

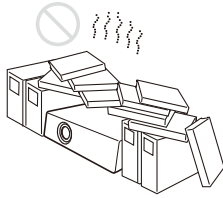

- Avoid using something to cover the ventilation holes (exhaust/intake).



- Do not place the unit on surfaces such as an original packing sheet, soft cloth, papers, rugs, or scraps of paper. The ventilation holes may take in such materials.

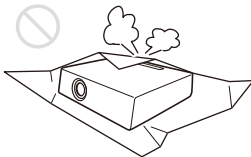

- Do not place any object in front of the lens that may block the light during projection. Heat from the light may damage the object. Use the blank function to cut off the picture.

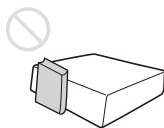

- Do not use the Security bar for the purpose of preventing theft for transporting or installing the unit. If you lift the unit by the Security bar or hang the unit by this bar, it may cause the unit to fall and be damaged, and may result in personal injury.

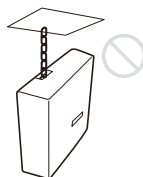

## For dealers

- When the projector is mounted on the ceiling, a Sony bracket or recommended equivalent must be used for installation.
- Be sure to secure the cabinet cover firmly when installing to the ceiling firmly.

## Safety precautions for installing the unit on a ceiling

- Never mount the projector on the ceiling or move it by yourself. Be sure to consult the store where you purchased the projector or a dedicated installer.
- When installing the unit on a ceiling, be sure to use a safety wire, etc., to prevent the unit from falling. For the installation, be sure to consult the store where you purchased the projector or a dedicated installer.
- To use the projector safely, ask the store where you purchased it or a dedicated installer for periodic inspections.

## On Installation

- When installing the unit, leave space between any walls, etc. and the unit as illustrated.

### Top view

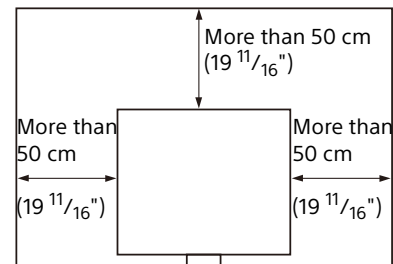

- Avoid using the unit if it is tilted more than 15 degrees horizontally.



- Avoid using the unit in a location where the temperature or humidity is very high, or temperature is very low.



- Avoid installing the unit in a location subject to direct cool or warm air from an air-conditioner. Installing in such a location may cause malfunction of the unit due to moisture condensation or rise in temperature.

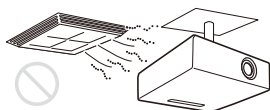

- Avoid installing the unit in a location near a heat or smoke sensor. Installing in such a location may cause malfunction of the sensor.

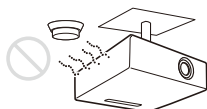

- Avoid installing the unit in a very dusty or extremely smoky environment. Otherwise, the air filter will become obstructed, and this may cause a malfunction of the unit or damage it.

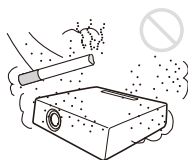

- When using the unit in a location at an altitude of 1,000 m (approx. 3,280 feet) or higher, appropriately set "High Altitude Mode" in the "Installation" menu. Failing to do so could have adverse effects, such as reducing the reliability of certain components.
- Avoid installing the product in a space where space disinfectant components containing hypochlorous acid and chlorine dioxide are dispersed. Also, avoid spraying sanitizers or disinfectants near the product. This may cause discoloration of the product, deterioration of the material, failure due to corrosion, and easy clogging of the air filter.

## Precautions for Portrait Installation

When installing the projector in portrait mode, make sure to position the projector with **exhaust ventilation holes** facing up, as illustrated.

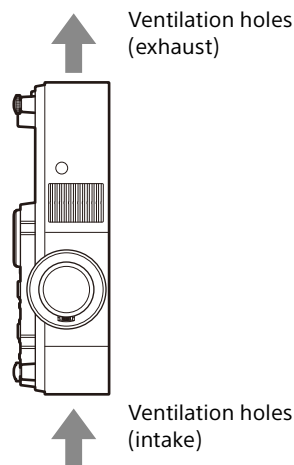

## On cleaning the lens and the cabinet

- Be sure to disconnect the AC power cord from the AC outlet before cleaning.
- If you rub on the unit with a stained cloth, the cabinet may be scratched.
- If the unit is exposed to volatile materials such as insecticide, or the unit is in contact with a rubber or vinyl resin product for a long period of time, the unit may deteriorate or the coating may come off.
- Do not touch the lens with bare hands.
- On cleaning the lens surface:
  - Wipe the lens gently with a soft cloth, such as a glass cleaning cloth. Stubborn stains may be removed with a soft cloth lightly dampened with water. Never use solvent such as alcohol, benzene or thinner, or acid, alkaline or abrasive detergent, or a chemical cleaning cloth.
- On cleaning the cabinet:
  - Clean the cabinet gently with a soft cloth. Stubborn stains may be removed with a soft cloth lightly dampened with mild detergent solution and wrung, followed by wiping with a soft dry cloth. Do not use alcohol, benzene, thinner, sanitizers, or disinfectants.

## On Illumination

To obtain the best picture, the front of the screen should not be exposed to direct lighting or sunlight.

## On Heat Dissipation

The temperature of the projector cabinet may increase during or immediately after use; however, this is not a malfunction.

## On Screen

When using a screen with an uneven surface, stripes pattern may rarely appear on the screen depending on the distance between the screen and the unit or the zooming magnifications. This is not a malfunction of the unit.

## On Fan

Since the projector is equipped with a fan inside to prevent internal temperature from rising, there may be some noise. This is a normal result of the manufacturing process and does not indicate a malfunction. If, however, in a case of abnormal noise, consult with qualified Sony personnel.

## About the Light Sensor

This unit has a function that uses the light sensor to detect the brightness of the surroundings to perform automatic image quality correction.

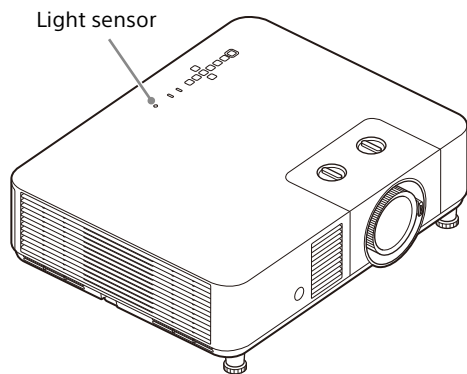

Do not block the light sensor when using automatic image quality correction based on the ambient brightness.

## On inspection of light source related parts

Since the unit uses a laser, when performing maintenance or inspection of light source related parts, particular attention and a safe environment are necessary. Be sure to consult with qualified Sony personnel.

## On disposing used products

Do not dispose the used products and general garbage together. Correctly dispose of used products to avoid harming the environment or the health of yourself and others. Follow the disposal regulations of your area.

## LCD Projector

The LCD projector is manufactured using high-precision technology. You may, however, see tiny black points and/or bright points (red, blue, or green) that continuously appear on the LCD projector. This is a normal result of the manufacturing process and does not indicate a malfunction.

Also, when you use multiple LCD projectors to project onto a screen, even if they are of the same model, the color reproduction among projectors may vary, since color balance may be set differently from one projector to the next.

## On condensation

If the room temperature where the projector is installed changes rapidly, or if the projector is moved suddenly from a cold to a warm place, condensation in the projector may occur. As the condensation may cause malfunction, be careful in adjusting temperature settings of the air conditioner. If condensation occurs, leave the projector turned on for about two hours before use.

## Notes on security

- SONY WILL NOT BE LIABLE FOR DAMAGES OF ANY KIND RESULTING FROM A FAILURE TO IMPLEMENT PROPER SECURITY MEASURES ON TRANSMISSION DEVICES, UNAVOIDABLE DATA LEAKS RESULTING FROM TRANSMISSION



SPECIFICATIONS, OR SECURITY PROBLEMS OF ANY KIND.

- Depending on the operating environment, unauthorized third parties on the network may be able to access the unit. When connecting the unit to the network, be sure to confirm that the network is protected securely.
- From a safety standpoint, when using the unit connected with the network, it is strongly recommended to access the Control window via a Web browser and change the access limitation settings from the factory preset values. Also, it is recommended that you set a password with a sufficiently long character string that is hard to guess by others, and that you store it safely.
- Do not browse any other website in the Web browser while making settings or after making settings. Since the login status remains in the Web browser, close the Web browser when you complete the settings to prevent unauthorized third parties from using the unit or harmful programs from running.
- When connecting this product to a network, connect via a system that provides a protection function, such as a router or firewall. If connected without such protection, security issues may occur.

### **Do not place this product close to medical devices**

This product (including accessories) has magnet(s) which may interfere with pacemakers, programmable shunt valves for hydrocephalus treatment, or other medical devices. Do not place this product close to persons who use such medical devices. Consult your doctor before using this product if you use any such medical device.

#### **Notes**

- Always verify that the unit is operating properly before use. SONY WILL NOT BE LIABLE FOR DAMAGES OF ANY KIND INCLUDING, BUT NOT LIMITED TO, COMPENSATION OR REIMBURSEMENT ON ACCOUNT OF THE LOSS OF PRESENT OR PROSPECTIVE PROFITS DUE TO FAILURE OF THIS UNIT, EITHER DURING THE WARRANTY PERIOD OR AFTER EXPIRATION OF THE WARRANTY, OR FOR ANY OTHER REASON WHATSOEVER.
- SONY WILL NOT BE LIABLE FOR CLAIMS OF ANY KIND MADE BY USERS OF THIS UNIT OR MADE BY THIRD PARTIES.
- SONY WILL NOT BE LIABLE FOR THE TERMINATION OR DISCONTINUATION OF ANY SERVICES RELATED TO THIS UNIT THAT MAY RESULT DUE TO CIRCUMSTANCES OF ANY KIND.

---

# License Notice

Refer to “Notice on the Software” in the Help Guide and read the contents of the license.

# Step 1

# Preparing

## Checking the Supplied Accessories

Remote Commander (RM-PJ8) (1)

Lithium battery (CR2025) (1)

The battery is already installed. Before using the remote commander, remove the insulation film.

AC power cord (1)

Light shield (1)

Setup Guide (this manual) (1)

## Installing batteries

- 1 Pull out the lithium battery compartment. Pull the battery compartment toward you while releasing the lock.

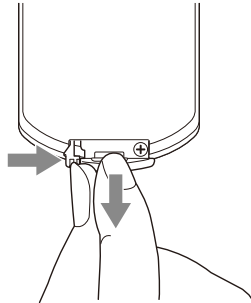

- 2 Insert a lithium battery. The lithium battery should be placed in the compartment with the plus side facing up.

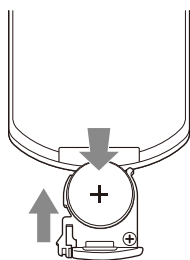

- 3 Close the lithium battery compartment.

## Removing the lens protection cushion

Make sure to remove the lens protection cushion before operating the unit.

When transporting the projector, adjust the lens shift to the center and attach the lens protection cushion.

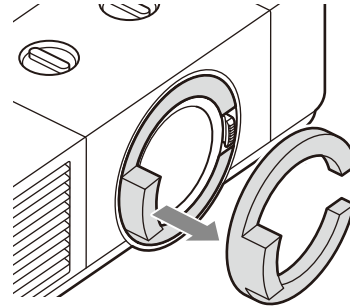

## Connecting the AC Power Cord

Plug the AC power cord into an AC IN socket.

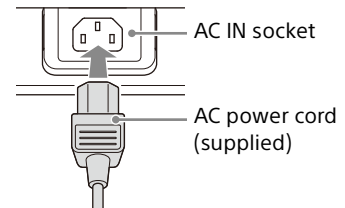

## Installing the light shield

Moving the H lens shift significantly may cause pale light to appear outside the effective area of the screen. If this is a concern, install the light shield.

After adjusting the projection position, zoom, and focus, turn off the power and attach the light shield to the lens of the projector.

**If there is a pale light on the right side of the screen**

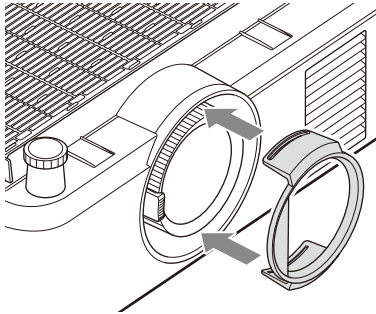

**If there is a pale light on the left side of the screen**

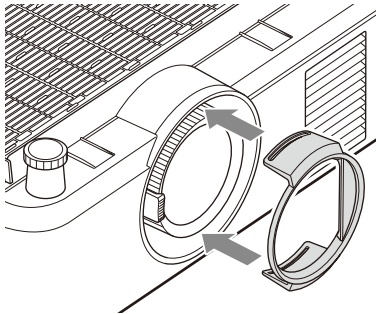

### Note

Do not install the light shield if no light appears outside the effective area of the screen. (If the light shield is installed in this case, the edges of the image may get cut off or appear dark.)

## Step 2

# Connecting

### Notes

- Turn off all devices before making any connections.
- Use the proper cables for each connection.
- Insert the cable plugs firmly; Loose connections may reduce performance of picture signals or cause a malfunction. When unplugging a cable, be sure to grip the plug, not the cable itself.
- For more information, refer also to the instruction manual of the device to be connected.

## Connecting to a Computer

Connect the INPUT B or INPUT C terminal to the HDMI output terminal on the computer.

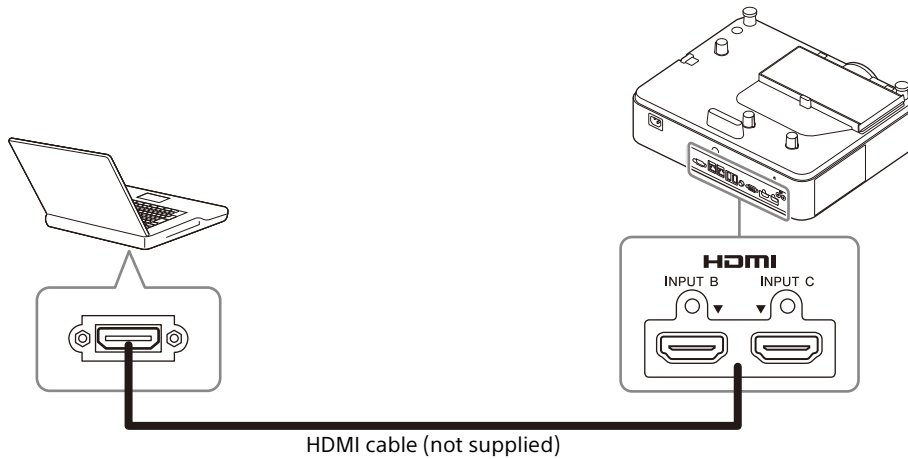

### Notes

- Use HDMI-compatible device which has the HDMI Logo.
- Use a "Premium High Speed" HDMI cable on which the cable type logo is specified. If using a cable other than a Premium High Speed cable, 4K images may not be displayed correctly.
- The HDMI terminal of this projector is not compatible with DSD (Direct Stream Digital) signal or CEC (Consumer Electronics Control) signal.

## Connecting to a Computer via a Hub or Router

### Using a LAN terminal

Connect the LAN terminal and the computer LAN terminal via a hub or router.

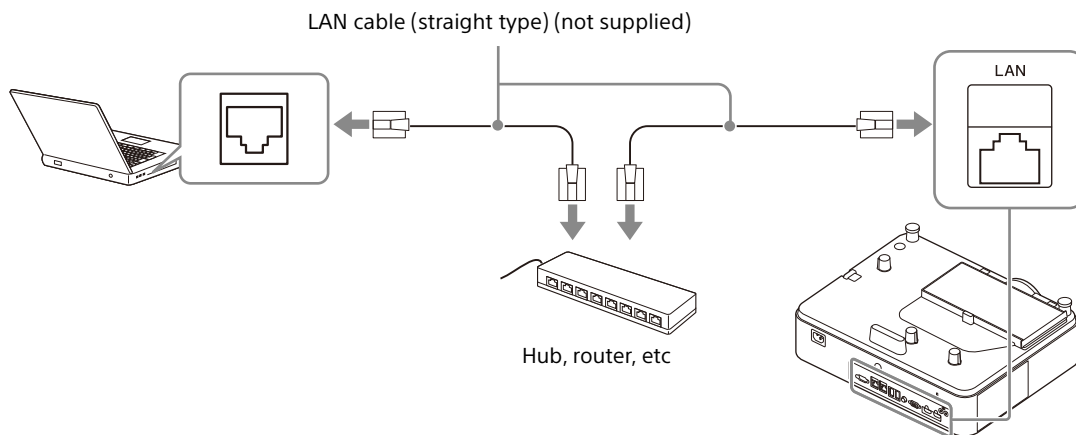

#### Notes

- When using network features via the LAN terminal, be sure to check if "LAN Setting" is set to "LAN Port".
- Connect the projector to the network that is constructed to control the access from the internet, such as LAN. If the projector is connected directly to the internet, the security risk is increased.

When you monitor and control the projector via the network, access the Control Window of the projector (refer to "Using Network Features" in the Help Guide) via a Web browser and enable the desired control protocol.

## Connecting to an HDBaseT™ Device

The HDBaseT transmitter is used when connecting the projector to a computer, video device, or network equipment.

### Notes for connecting this unit to the HDBaseT transmitter

- Ask a professional or Sony dealer to perform wiring. If wiring has been insufficiently performed, it affects the transmission characteristics of the cable, and causes broken or unstable images.
- Connect the cable directly to the HDBaseT transmitter without going through a hub or router.
- Use cables that meet the following conditions.
  - CAT5e or higher
  - Shielded type (covering connectors)
  - Straight wire connection
  - Single wire
- When installing the cables, use a cable tester, cable analyzer, or similar device to check if the cables meet the CAT5e or higher requirement. If there is a transit connector between this unit and the HDBaseT transmitter, include it when measuring.
- To reduce the affect of noise, install and use the cable in a manner where it is not rolled up and it is as straight as possible.
- Install the cable away from the other cables (especially the power cable).
- When installing multiple cables, do not bind them and keep the running parallel distance as short as possible.
- The transmittable distance of the cable is 100 m (approx. 328 feet) maximum. If it exceeds 100 m (approx. 328 feet), it may cause broken images or a malfunction in LAN communication. Do not use the HDBaseT transmitter beyond the maximum transmittable distance of the cable.
- For operation or function problems caused by devices of other manufacturers, contact the relevant manufacturer.

## Connecting to a computer/video device

Connect the HDBaseT terminal to the HDMI output terminal on a computer or video device.

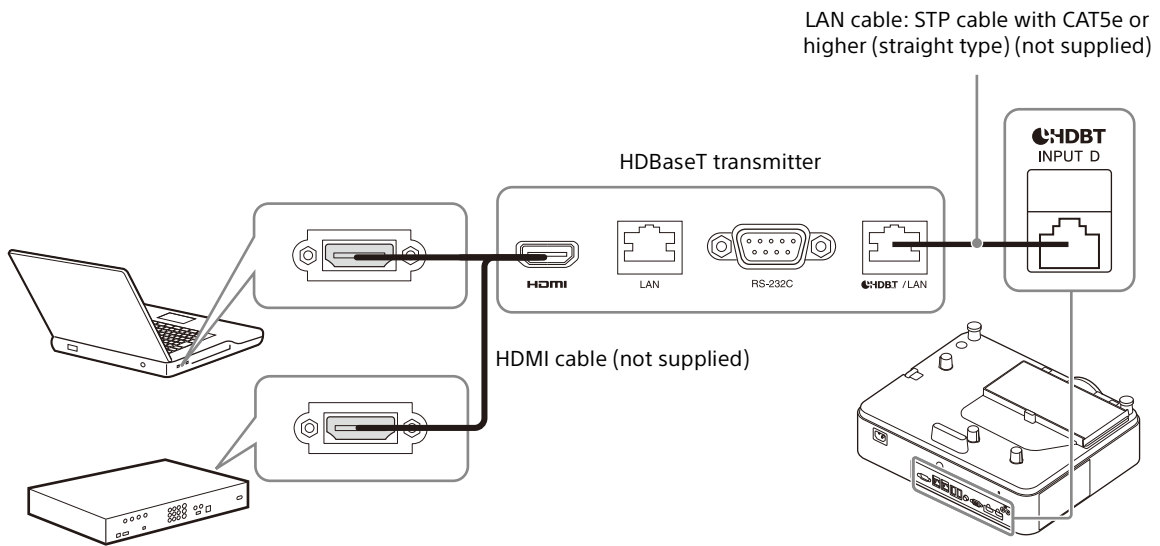

*For information on other connecting methods, refer to "Connecting" in the Help Guide.*

### Turning the Projector On/Off

- 1 Plug the AC power cord into a wall outlet.
- 2 Turn on the projector.  
Press the I/⏻ key on the unit or the Remote Commander.

### Turning Off the Power

- 1 Press the I/⏻ key on the unit or the Remote Commander.  
The projector starts shutdown and turns off.  
For long-term use, turn off the projector when not in use.
- 2 Unplug the AC power cord from the wall outlet.

### Making Initial Settings

When you turn on the power of the unit for the first time after purchase, the initial setting screen is displayed. Follow the steps below to make the settings.

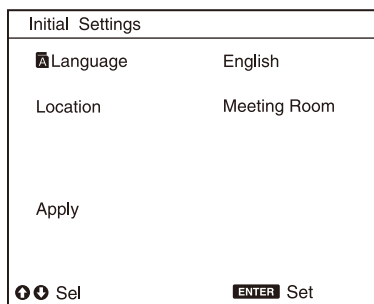

- 1 Select the display language.
  - ① Press the ↑ or ↓ key to select “Language”, then press the ENTER key.
  - ② Press the ↑/↓/←/→ keys to select a language, then press the ENTER key.
- 2 Set the installation location.
  - ① Press the ↑ or ↓ key to select “Location”, then press the ENTER key.
  - ② Press the ↑ or ↓ key to select an installation location, then press the ENTER key.

- 3 Save the settings.  
Press the ↑ or ↓ key to select “Apply”, then press the ENTER key.  
When the initial setup is complete, the projector starts up.



## Projecting an Image

The size of a projected image depends on the lens or the distance between the projector and screen. Place the projector so that the projected image fits the screen size. For details on projection distances and projected image sizes, see "Projection Distance" in the Help Guide.

- 1 Plug the AC power cord into a wall outlet.
- 2 Connect all necessary devices to the projector (page 40).
- 3 Turn on the projector.  
Press the **I/⏻** key on the unit or the Remote Commander.
- 4 Turn on the connected device.
- 5 Select the input source.  
Press the **INPUT** key on the projector or on the Remote Commander to display the input select window. Press the **INPUT** key repeatedly or the **▲/▼** key to select an image to be projected.
- 6 Change the computer screen output destination to an external display.  
How to change the output destination varies, depending on the type of computer.  
(Example)  

- 7 Adjust the focus, size and position of the projected image (page 44).

## Adjusting the Projected Image

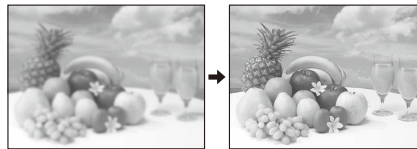
### Focusing the image (Focus)

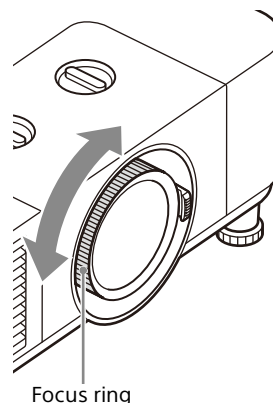

Turn the focus ring.



### Adjusting the image size (Zoom)



Turn the zoom lever.

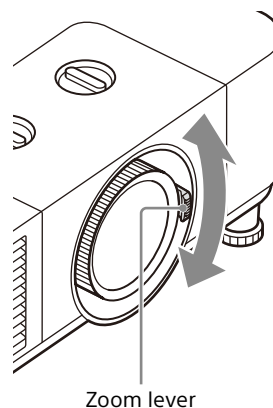

---

## Adjusting the position of the image

### Adjusting the tilt of the projector by using lens shift



Turn the H lens shift dial to adjust the lens horizontally or turn the V lens shift dial to adjust the lens vertically.

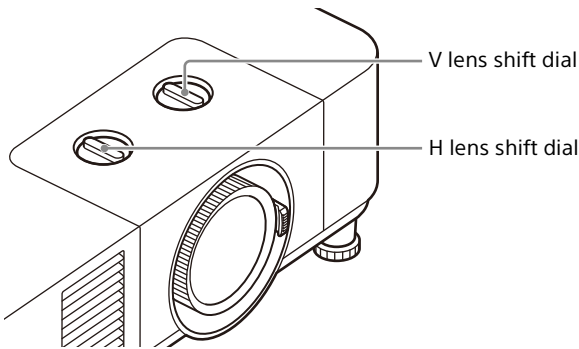

### Adjusting the tilt of the projector with the front feet (adjustable)

If the projector is installed on an uneven surface, adjust the position of the projected image by changing the tilt of the projector with the front feet (adjustable).

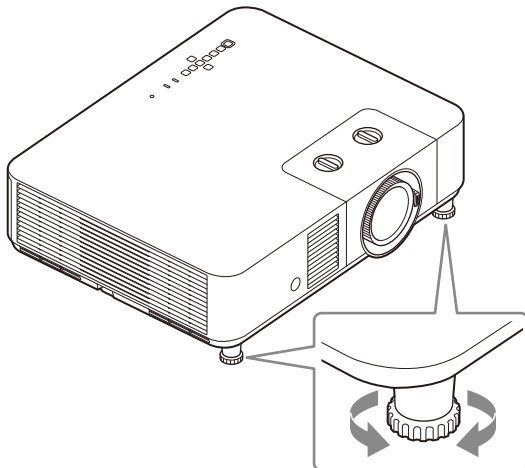

#### Notes

- Be careful not to let the projector down on your fingers.
- Do not push hard on the top of the projector with the front feet (adjustable) extended. It may cause malfunction.

*If you need to further adjust projected images, refer to "Adjusting" in the Help Guide.*

# Indicators

You can check the projector status or abnormality by checking the lighting/flashing status of the ON/STANDBY indicator and WARNING indicator on the top. If the indicators flash in red, address the problem in accordance with "Warning indication and remedies" (page 47).

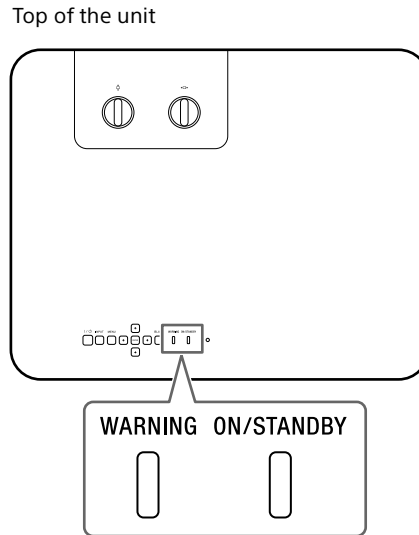

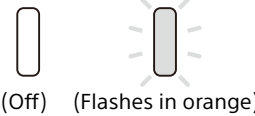

## Status indication

Indicator status	Operating status	Description
<p>WARNING ON/STANDBY</p> <p>(Off) (Lights in red)</p>	Standby	The power is supplied to the projector and the projector is in a standby mode according to the setting.
<p>WARNING ON/STANDBY</p> <p>(Off) (Flashes in green)</p>	Warm-up	The projector is warming up after it is turned on.
<p>WARNING ON/STANDBY</p> <p>(Off) (Lights in green)</p>	Power on	The projector is ready for projection.
<p>WARNING ON/STANDBY</p> <p>(Off) (Lights in orange)</p>	Other standby status	The projector is in With No Input (Light Cutoff) or the speaker setting is set to "Always On."

Indicator status	Operating status	Description
WARNING ON/STANDBY  (Off) (Flashes in orange)	Updating software	The projector software is being updated.

### Warning indication and remedies

Indicator status	Number of flashes	Meaning/Remedies
WARNING ON/STANDBY  (Flashes in red) (Lights in red)	Twice	The top cover is not properly attached. Check the attachment of the top cover. If it has been loosened due to a strong impact to the projector, consult with qualified Sony personnel.
WARNING ON/STANDBY  (Flashes in red) (Lights in red)	Three times	The light source does not light properly. Unplug the AC power cord and make sure the ON/STANDBY indicator turns off, then plug the AC power cord into the wall outlet and turn on the projector.
WARNING ON/STANDBY  (Flashes in red) (Flashes in red) Both indicators flash	Twice	The temperature in the projector is abnormal. Perform the following. <ul style="list-style-type: none"> <li>• Check if the air filter is clogged, then clean or replace it (page 48).</li> <li>• Check if the ventilation holes (intake/exhaust) are not blocked by the wall or an object and secure a sufficient gap.</li> <li>• Check the ambient temperature and use the projector within the range of operating temperature.</li> </ul>

If the indicators flash in a manner other than described above, unplug the AC power cord and make sure the ON/STANDBY indicator turns off, then plug the AC power cord into the wall outlet and turn on the projector.

If the problem still persists, consult with qualified Sony personnel.

*If there is any problem or an error message appears on the screen, refer to "Messages List" or "Troubleshooting" in the Help Guide.*

# Maintenance

## Cleaning the Outer Panel/Air Filter of the Projector

Clean the air filter and ventilation holes (exhaust/intake) periodically.

Clean the air filter when the message that prompts cleaning the air filter appears. The message that prompts cleaning the air filter appears when a clogged air filter is detected or when the time set by the "Filter Timer Notif" has elapsed.

### Caution

If you continue to use the projector with the air filter clogged, the internal temperature will rise, and this may cause a malfunction.

- 1 Turn off the projector, and disconnect the AC power cord from a wall outlet.

### Notes

- If you clean the projector without disconnecting the power cord, the fan may spin by accidentally turning the power on, and this may cause damage or injury.
- If you remove the air filter cover while the power is turned on, you may accidentally touch the fan inside the projector, and this may cause injury.

- 2 Vacuum the dust around the air filter cover and ventilation holes (exhaust/intake) with a vacuum cleaner.

- 3 Slide the air filter cover sideways to remove it. If dust remains in the area where the air filter cover has been removed, vacuum it with a vacuum cleaner.

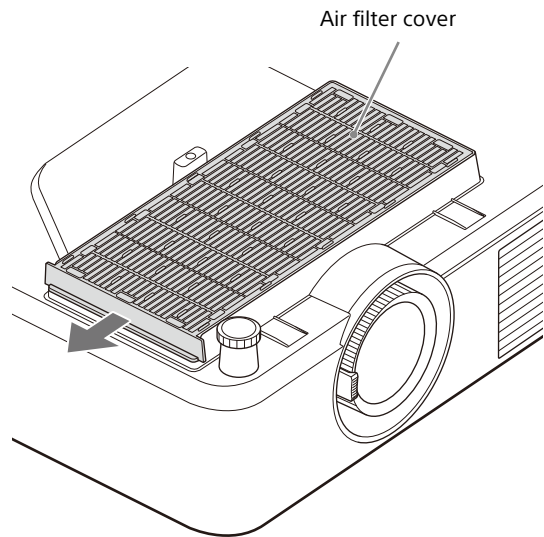

### Notes

- Do not use a brush to remove dust. Dust may fall inside the projector, and this may cause a malfunction.
- Be sure to attach the air filter when using the projector. If you use the projector without the air filter, dust will be sucked into it, and this may cause a malfunction.

- 4 Pull the air filter pull stick upwards, and remove the air filter from the air filter cover.

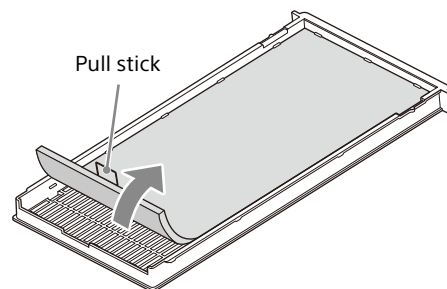

- 5 Vacuum the dust from the front side (the side without the pull stick) of the air filter with a vacuum cleaner.

### Notes

- Do not vacuum the dust from the back side (the side with the pull stick) of the air filter. This may cause clogging.
- Do not spread out the filter surface or do not press the nozzle of a vacuum cleaner forcibly against it. This may cause damage to the air filter.

- Do not rub the surface of the air filter with a brush. This may cause dust to be pushed into the air filter or damage the air filter.
- Do not use high-pressure air such as an air duster. This may cause dust to be pushed into the air filter, a problem due to the adhesion of contained substances, or damage to the air filter.

- 6** Attach the air filter to the air filter cover so that the pull stick protrudes outwards from the air filter cover.  
Attach so that there is no gap between the air filter and air filter cover.

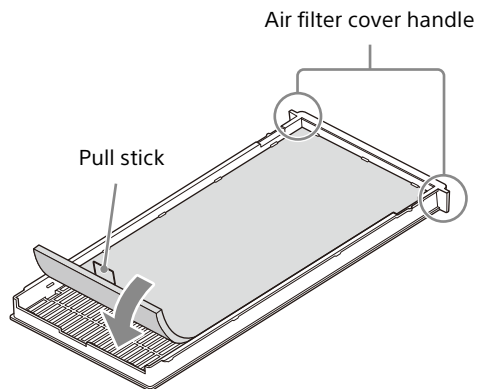

#### Notes

- When attaching the air filter to the air filter cover, ensure that the pull stick side of the air filter is on the opposite side of the air filter cover handle. Also, ensure that the surface with the pull stick is facing up.
- Securely attach the air filter to the air filter cover, taking care not to hit the hook of the air filter cover. If the air filter is attached to the air filter cover incorrectly, this may cause a malfunction.

- 7** Attach the air filter cover to the projector. Fully push it in so that there is no gap between the air filter cover and the outer panel surface of the projector.

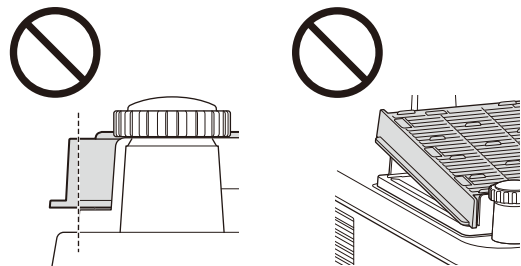
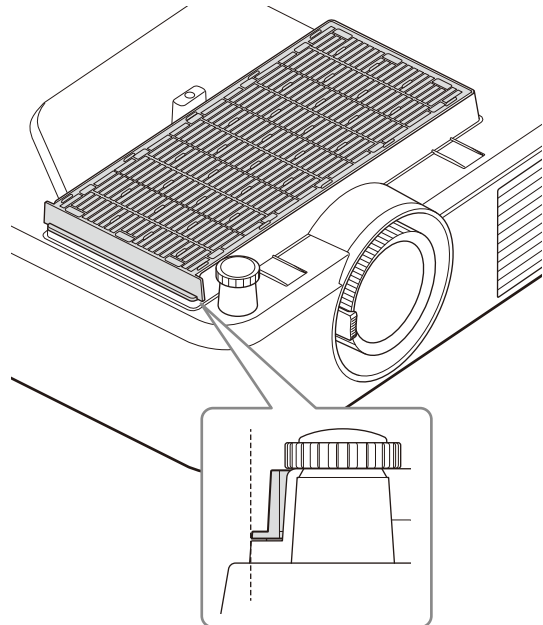

### Replacing/Discarding the Air Filter

In the following cases, replace the air filter with a new one.

- When the message for cleaning the air filter is displayed right after cleaning the air filter with a vacuum cleaner.
- When the indicator flashes in red right after cleaning the air filter with a vacuum cleaner.

- 1 Remove the air filter according to "Cleaning the Outer Panel/Air Filter of the Projector" (page 48).
- 2 Attach a new air filter to the air filter cover so that the pull stick protrudes outwards from the air filter cover.  
Attach so that there is no gap between the air filter and air filter cover.

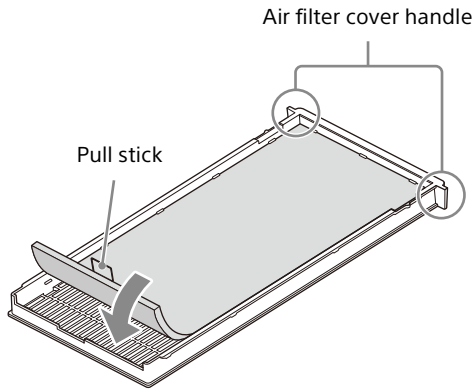

**Notes**

- When attaching the air filter to the air filter cover, ensure that the pull stick side of the air filter is on the opposite side of the air filter cover handle. Also, ensure that the surface with the pull stick is facing up.
- Securely attach the air filter to the air filter cover, taking care not to hit the hook of the air filter cover. If the air filter is attached to the air filter cover incorrectly, this may cause a malfunction.

- 3 Attach the air filter cover to the projector. Fully push it in so that there is no gap between the air filter cover and the outer panel surface of the projector.

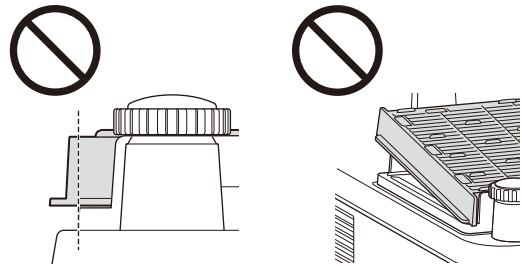
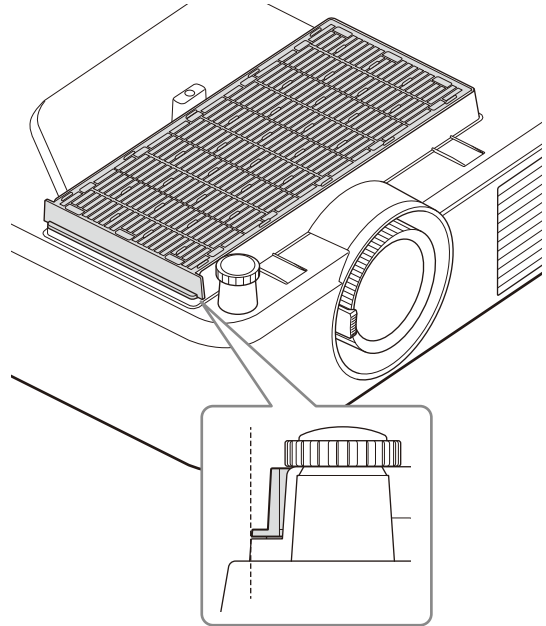

Follow the laws and regulations of your country or region when disposing the air filter.

**Materials**

- Air filter (white part): PP, PET
- Cushion (black part): NBR

# Notes on Installing the Ceiling Bracket

When installing the free-type ceiling bracket as shown in the figure to the unit, it is recommended to use 4 screws to fix it in a stable position considering the center of gravity of the unit. (Fixing with 3 screws is essential).

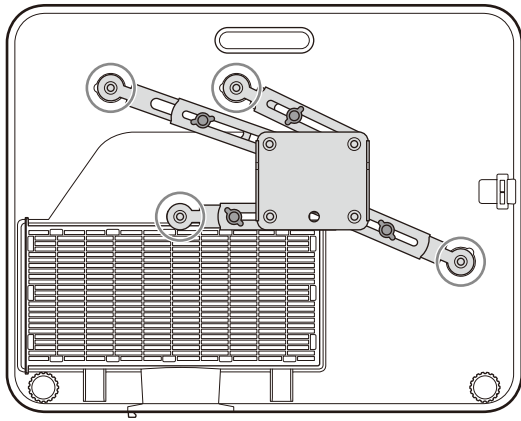

It is recommended to install it so that the ceiling bracket does not overlap on the air filter cover during installation. If they overlap, it is recommended to install them within the range of A in the figure so as not to interfere with the intake from the air filter.

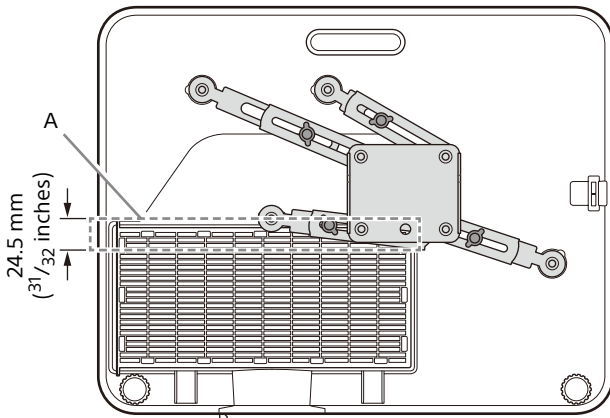

## Note

To use the projector safely, ask the store where you purchased it or a dedicated installer for periodic inspections.



# Dimensions

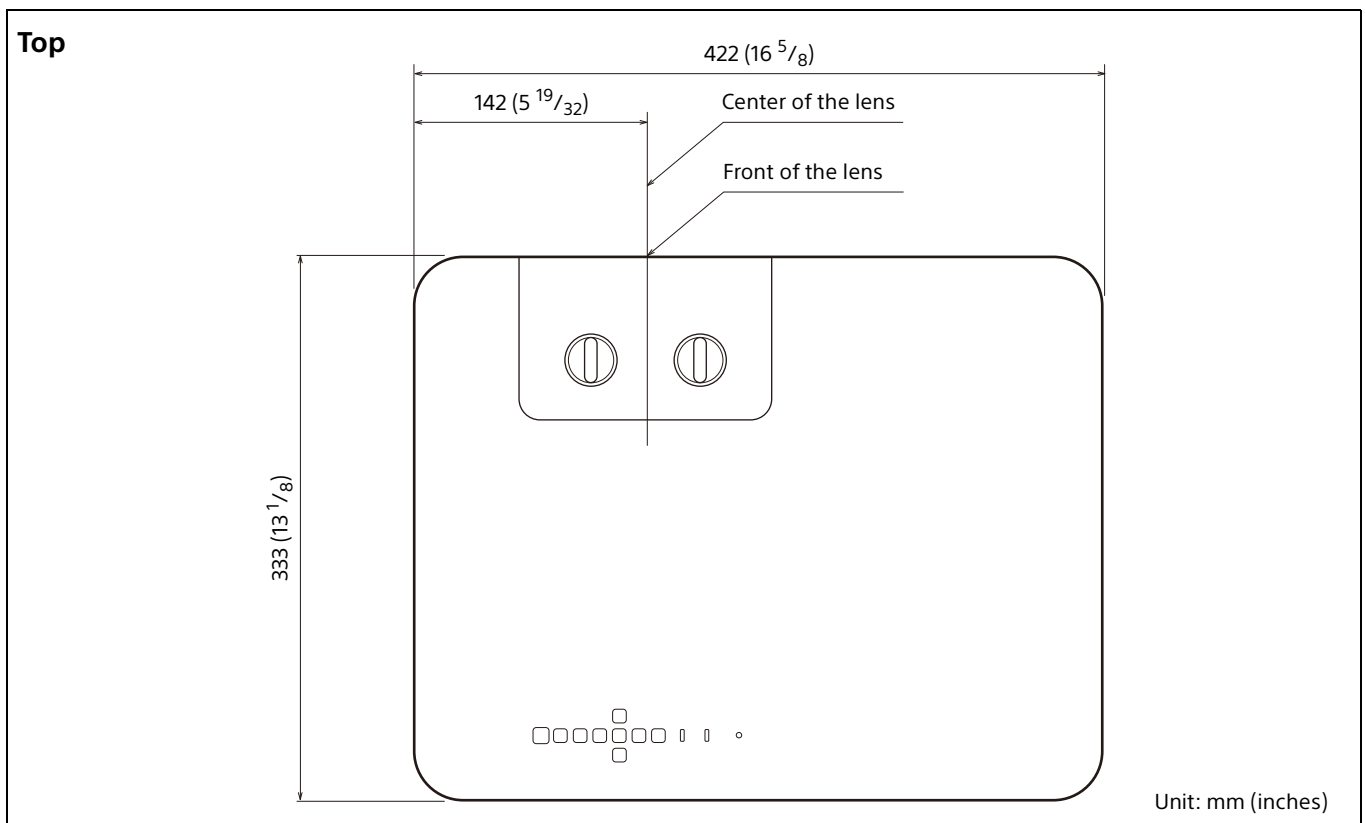
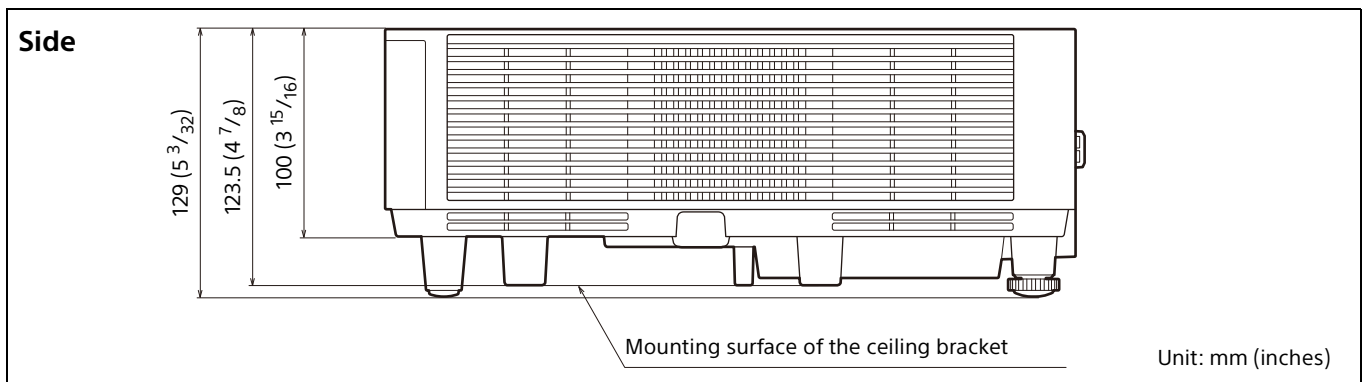
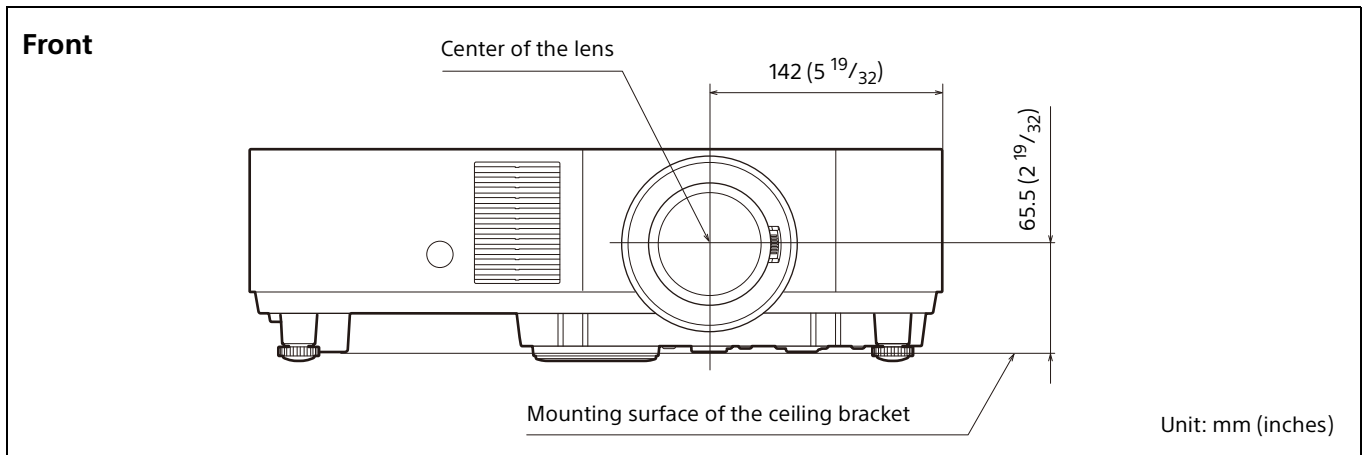

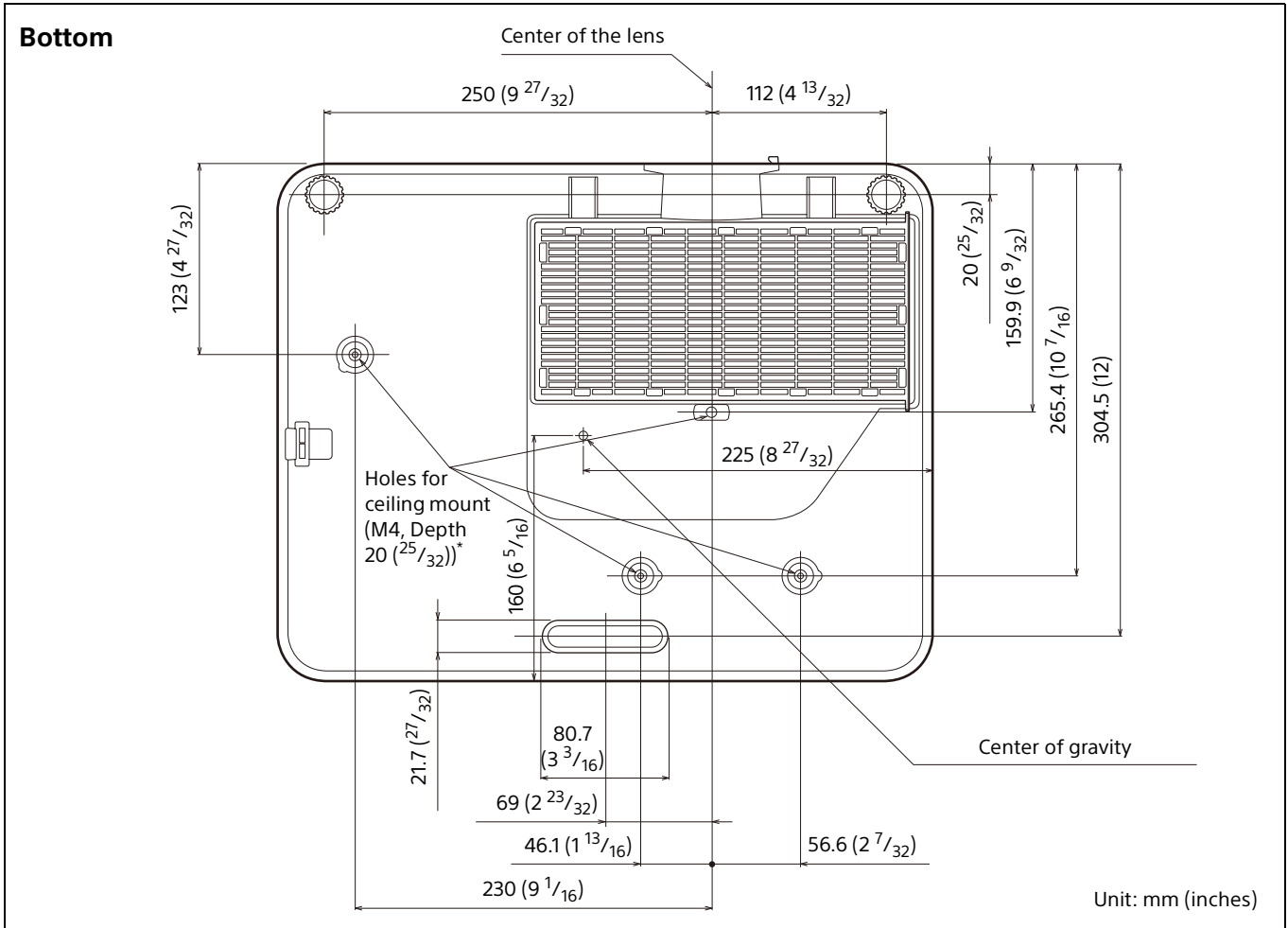

**\* Specifications of ceiling mount holes**

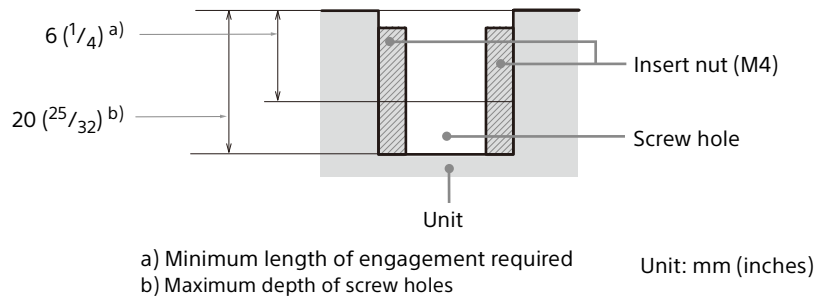

- Be sure to use screws that are longer than the minimum length of engagement and shorter than the maximum depth of screw holes as shown in the figure above.
- Recommended tightening torque: 1.1 ±0.1 N·m