

"OPTICAL CABLE CORPORATION (OCC)
RESERVES THE RIGHT TO REVISE ANY
AND ALL DESIGN SPECIFICATIONS."

UNCONTROLLED COPY

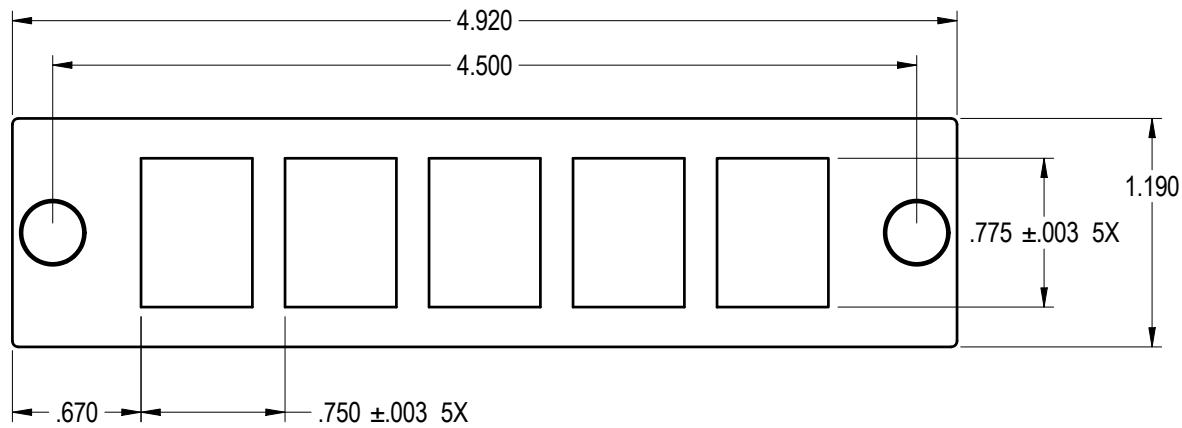

FRONT VIEW

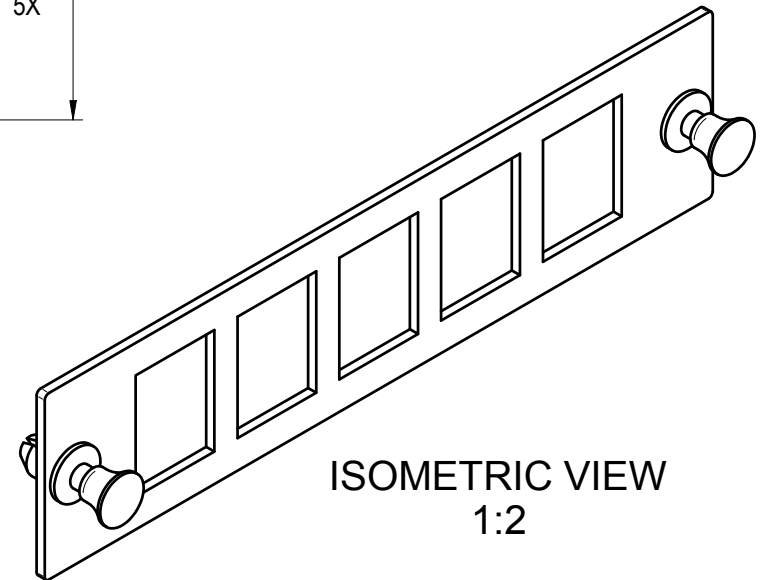
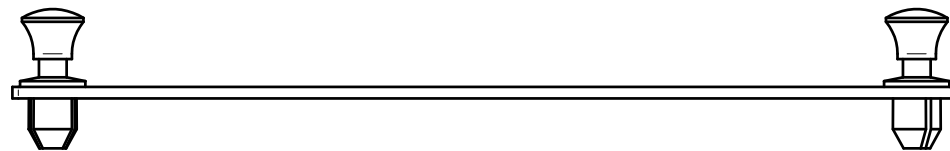

ISOMETRIC VIEW
1:2

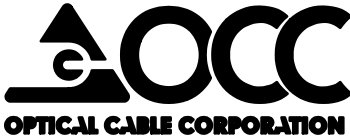
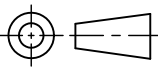
605AKX		PLATE, KMJX5 MTG, UNLOADED	
OCC PART NO.		DESCRIPTION	
UNLESS OTHERWISE SPECIFIED DIMENSIONS ARE IN INCHES. TOLERANCES: FRACTIONS $\pm 1/32"$ ANGLES $\pm 1/2^\circ$ 3 PLACE DECIMALS $\pm .005"$ 2 PLACE DECIMALS $\pm .01"$	THIS DRAWING AND THE DESIGN SHOWN ARE THE PROPERTY OF OPTICAL CABLE CORPORATION AND MAY NOT BE USED AS THE BASIS FOR MANUFACTURE OR SALE WITHOUT SPECIFIC WRITTEN PERMISSION OF OPTICAL CABLE CORPORATION.		
	DRAWN D.A.HOLBERT CHECKED D.Stikeleather ENGINEER J.YANIK APPROVED J.HOWE PREVIOUS DWG NEXT DWG	DATE 2/13/15 DATE 2/16/15 DATE 2/13/15 DATE 2/16/15	 33 Superior Way Swannanoa, NC 28778 Phone: 828-298-2260 Fax: 828-298-2487 www.occfiber.com
THIRD ANGLE PROJECTION 	MATERIAL PLATE: 16 GAGE CRS GROM/PLNG: BLACK PLASTIC	DWG TITLE ADAPTER PLATE ASSY, KMJ, 5 PORT, UNLOADED	
CRITICAL DIMENSION CODE (F) = FUNCTION (M) = MATING (A) = AUDIT	FINISH PLATE PAINT: BLACK PER OCC SPEC# 10002501	SIZE A	DWG NO. C112133
		FILENAME C112133A.dft	SCALE: NONE SHEET 1 OF 1
			REV A