

**Features**

- NEMA 4
- Suitable for use on pressure or gravity switches
- Mounts to wood or steel tanks
- **NOTE:** Wood tanks require optional buttress adapter
- Product includes a 5 year warranty



**Description**

The Model WLS Water Level Switch is a float operated device for supervising water level in a sprinkler supply gravity or pressure tank.

The Model WLS has a bushing with 1 1/2" American Standard Pipe Threads for mounting in steel tanks. A 1 1/2" NPT x 2" NPT adapter bushing is available for mounting in existing 2" steel flanges. An optional bushing adapter with a buttress thread is available for mounting in wooden tanks.

The unit is capable of detecting the level of water before a 3" (7,6cm) rise and/or a 3" (7,6cm) fall in the water level in a pressure tank, as required for NFPA 72.

The cover is a weather/UV/flame resistant high impact composite plastic and is held in place with two tamper resistant screws (provided), which require a special key for removal.

**Technical Specifications**

Dimensions	Housing - 5.56"H x 3.50"W x 2.56"D 14,1cm H x 8,9cm W x 6,5cm. See Fig. 1
Weight	3.25 lb / 1.47 Kg
Enclosure	Cover: Weather/UV/Flame Resistant High Impact Composite Base: Steel zinc plated
Applications	Steel or wood tanks (With the optional wood bushing adapter, Stock No. 5180199)
Contacts	Two sets SPDT (Form C) One set for high / One set for low Rated - 15.00 Amps at 125/250VAC 0.50 Amp at 125VDC 0.25 Amp at 250VDC
Detection Range	Before 3" (7,6cm) Rise / Before 3" (7,6cm) Fall
Environmental Specifications	<ul style="list-style-type: none"> <li>• Temperature range: 40°F to 140°F (4,5°C to 60°C)</li> <li>• NEMA 4/IP54 Rated Enclosure suitable for indoor or outdoor use with factory installed gasket when used with appropriate conduit fitting.</li> </ul>
Maximum Pressure	175 PSI (12,1 BAR)
Cover Tamper	Cover incorporates tamper resistant fasteners that requires a special key for removal. One key is supplied with each device

**Dimensions**

Fig 1

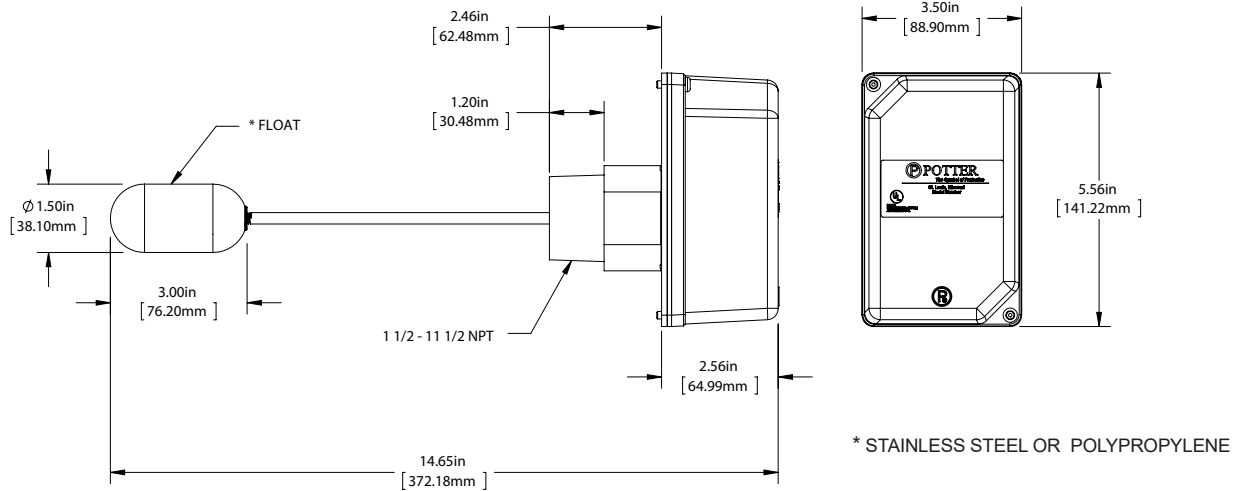

**Installation Instructions**

A buttress thread nut and gasket are available for use with devices on installations where the inside of the tank is accessible and it is not convenient to weld a flange on the tank. The nut and gasket can also be used in a wood tank that is not sound enough to hold a thread (see Fig. 2).

For installation in steel gravity tanks, weld a 1 1/2" NPT threaded flange (#6660225) 9" (23cm) below the required water level to receive the 1 1/2" bushing (see Fig. 3).

For wood gravity tanks, bore a 2 3/8" (60mm) hole in the center of a stave 9" (23cm) below the required water level and screw the buttress bushing adapter (#5180199) in place, allowing the bushing to cut its own thread, then install the WLS into the adapter (see Fig. 4).

For pressure tanks, weld the 1 1/2" NPT threaded flange (#6660225) into the tank at the desired water level and use both high and low signals.

To replace an existing Potter WLS in a steel tank with a welded flange a 1 1/2" x 2" NPT bushing adapter (#5020126) is available. Thread the bushing adapter into the 2" welded flange securely then install the WLS into the adapter.

**NOTE:** The high signal is not required for gravity tanks and the WLS can be wired so that either High or Low or both switches may be used (see Fig. 5).

**WARNING**  
Do not lift or hold device by float or float rod as bending may occur.

**Wood or Steel Tank Installation**  
Fig 2

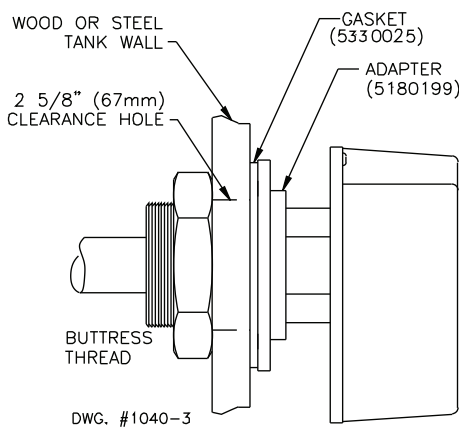

**Steel Tank Installation**  
Fig 3

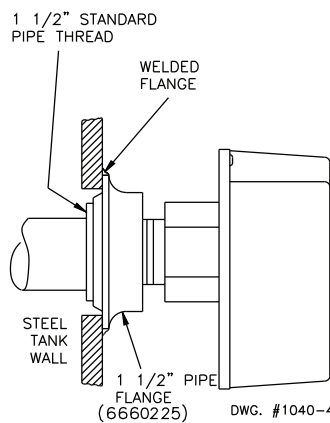

**Wood Tank Installation**  
Fig 4

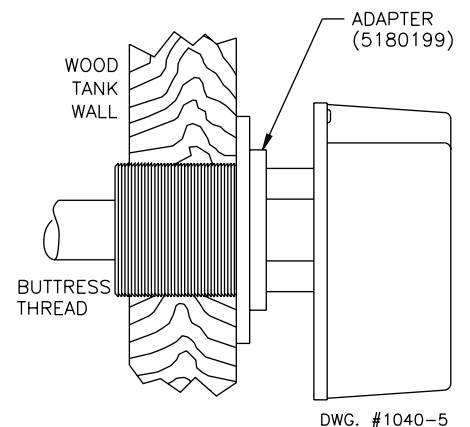

**Orientation and Switch Placement**

Fig 5

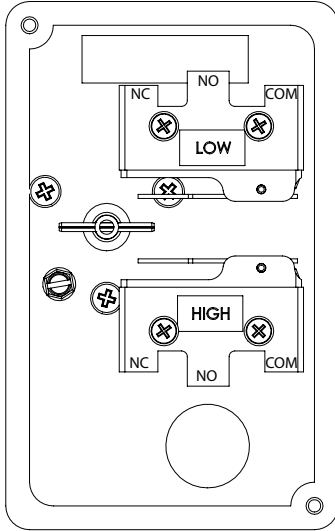

**NOTE:** Device must be oriented vertically with conduit entrance toward bottom of water tank.

**Ordering Information**

Model	Description	Stock No.
WLS	Water Level Switch	1010117
1 1/2" Flange-Forged Steel		6660225
2 1/2" Buttress Nut-Bronze		6660083
Gasket-Neoprene		5330025
Buttress Adapter-Brass	1 1/2" NPT x 2 1/2"	5180199
Reducer Bushing Adapter-Brass	1 1/2" NPT x 2" NPT	5020126

**Switch Plate Terminal Connections  
Clamping Plate Terminal**

Fig 6

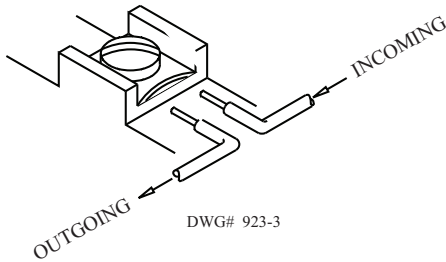

**⚠ WARNING**

An uninsulated section of a single conductor should not be looped around the terminal and serve as two separate connections. The wire must be severed, thereby providing supervision of the connection in the event that the wire becomes dislodged from under the terminal.