

MM340 Standard Pull Down TV Mount

- ▶ **Read this entire manual before you begin.**
- ▶ **Do not unpack box contents until verifying the requirements listed on page 2-3.**

INSTALLATION INSTRUCTIONS

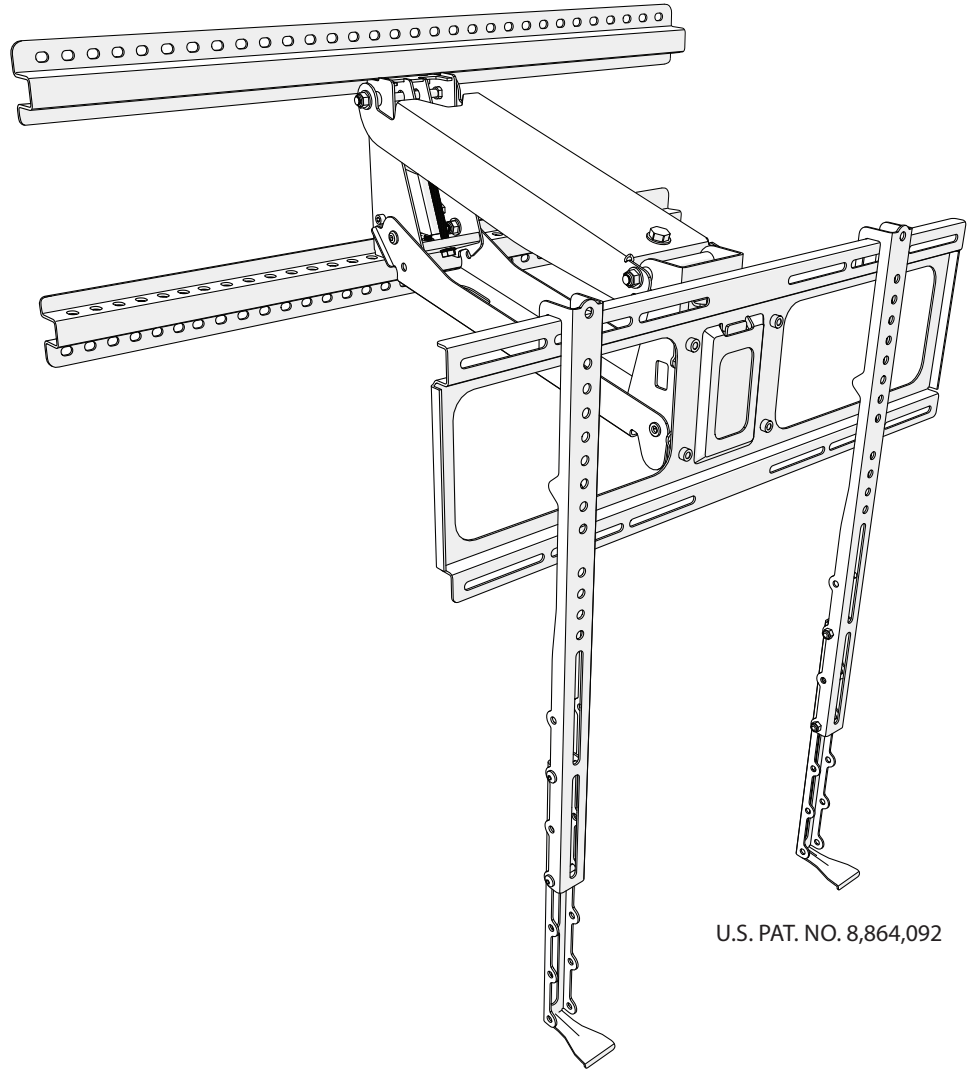

U.S. PAT. NO. 8,864,092



If you need help, call 1.800.897.9755 ext.1

For missing/damaged parts or questions during installation, please contact our Customer Support team at **1.800.897.9755 ext.1** or **support@mantelmount.com**. Customer satisfaction is our highest priority!

Contains important safety information – please save! MantelMount.com

BEFORE INSTALLATION

1 Verify TV and mount space meet these criteria:

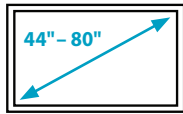

SCREEN SIZE
44" to 80"
(Diagonally)



WEIGHT CAPACITY
20 to 90 LBS.
(Including Sound Bar)*
*MM340 requires accessory for sound bar, visit mantelmount.com.

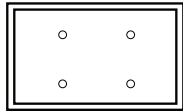

VESA COMPLIANT
Width: 200–600mm
Height: 200–600mm

MANTEL DEPTH
18" MAXIMUM

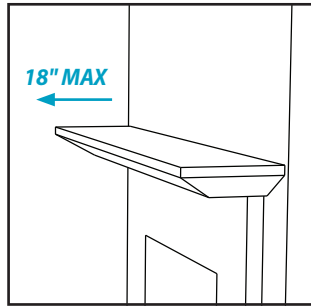

WOOD STUDS FOR MOUNTING
Studs Maximum 28" apart;
Wall Covering Maximum 5/8"

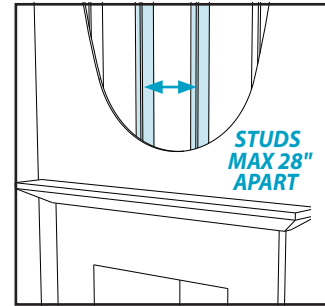

2 Verify MantelMount will fit the wall space.

A. Use the reference diagram (right) and chart (below) to write down the following measurements (in inches):

Wall Space Height: _____ (Distance from mantel to ceiling/crown moulding.)

TV Height: _____ (Include sound bar height if placing below TV.)

Mantel Depth: _____ (Distance mantel extends away from the wall.)

Required Vertical Space: _____ (Calculation from chart below.)

B. If the Required Vertical Space is less than or equal to the Wall Space Height, then MantelMount will fit the wall space.

If Mantel Depth is:	Required Vertical Space is:
Less than 9"	TV height + 4"
9" – 11"	TV height + 5"
11" – 14"	TV height + 6"
14" – 18"	TV height + 8"

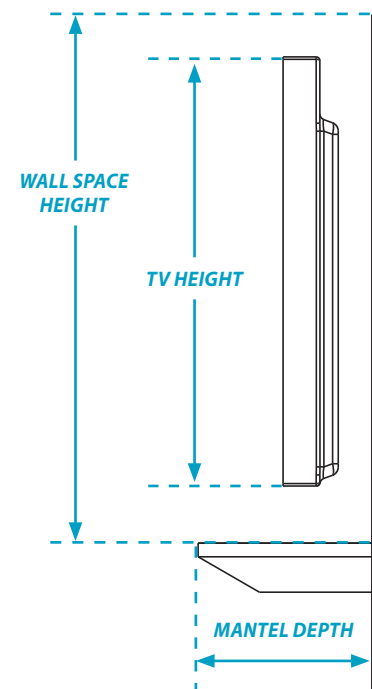

3 Verify you have the required tools.

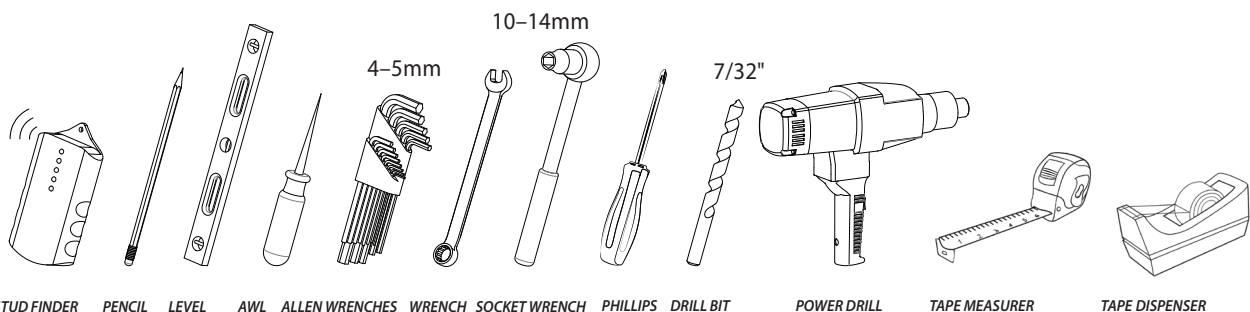

BEFORE INSTALLATION

4 Verify all parts are included.

SILVER SCREWS FOR BACK OF TV

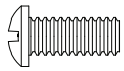

{01} x4
M5x12

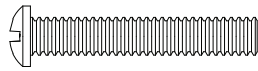

{02} x4
M5x30

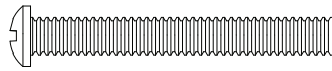

{03} x4
M5x40

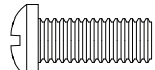

{04} x4
M6x16

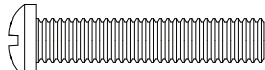

{05} x4
M6x30

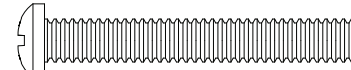

{06} x4
M6x40



{07} x4
M8x15



{08} x4
M8x25



{09} x4
M8x45

BLACK PARTS FOR MOUNT

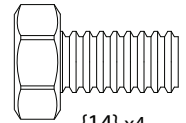

{14} x4
HEX M8x15

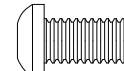

{15} x8
M6x10



{23} x4
Locknut M6

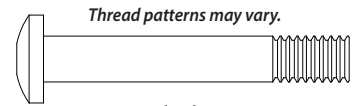

Thread patterns may vary.

{18} x4
M6x40

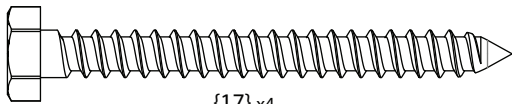

{17} x4
Lag Bolt

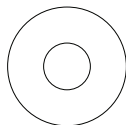

{10} x4
M5-M6

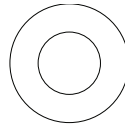

{11} x8
M8

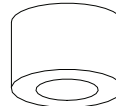

{12} x12
Spacer

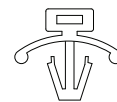

{22} x2
Anchor

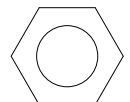

{27} x1
Safety Nut M8

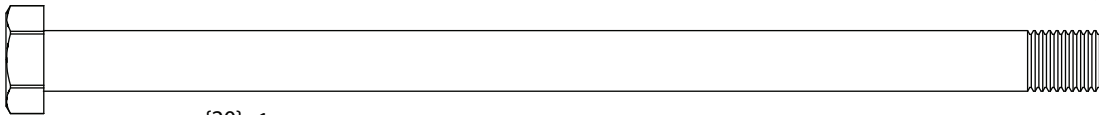

{20} x1
Safety Bolt

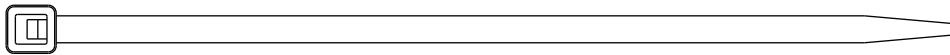

{24} x4
Cable Ties

▶ If any parts are missing or damaged, contact Customer Support at 1-800-897-9755 ext.1 before installing.



{31} x2
Vertical Brace

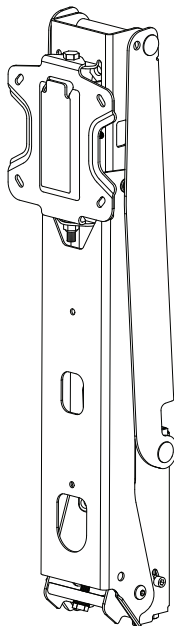

{35} x1
Lifting Arm

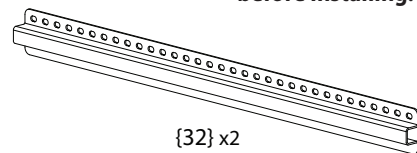

{32} x2
Wall Plate

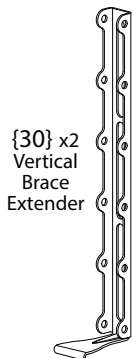

{30} x2
Vertical Brace Extender

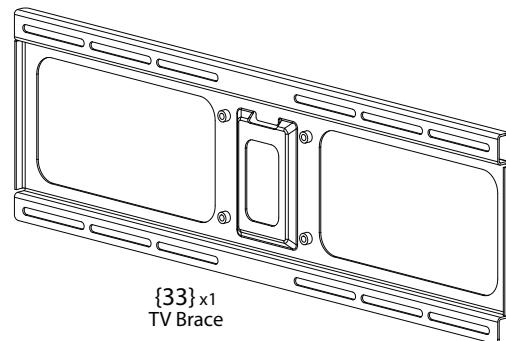

{33} x1
TV Brace

MM340 INSTALLATION STEPS

STEP 1 Attach Braces to TV	PAGE 5
STEP 2 Determine Wall Placement	PAGE 7
STEP 3 Attach Mount to Wall	PAGE 10
STEP 4 Attach TV to Mount	PAGE 12
STEP 5 Make Final Adjustments	PAGE 14

⚠ WARNING

Keep children away from the work area during installation.
This product contains small parts, please keep out of reach from children.

⚠ WARNING

Do not remove the gas springs or any bolts that hold the Lifting Arm together.

⚠ WARNING

Do not let small children pull on or hang from MantelMount.

Only persons tall enough to control the product all the way to the top/raised position should operate MantelMount.

Do not allow small children to push MantelMount upward to the top position. This will cause the mount to slam against the wall due to the upward force of the springs.

⚠ CAUTION

This product is intended to be installed by professional contractors or persons familiar with the tools and methods required for this installation.

If you are uncertain about your ability to perform this installation, please contact a professional.

Do not use this product in any way or for any purpose that is not specifically described in these instructions.

⚠ CAUTION

Do not use this product for purposes not specifically described in these instructions.

MantelMount is not responsible for damage or injury caused by incorrect installation or improper use.



Symbols Used in this Manual



CAUTION / WARNING



HELPFUL INFORMATION



DO NOT



SPECIAL NOTE



REQUIRES TWO PEOPLE

- ▶ **Two people required for parts of this installation.**
- ▶ **Installation Tips & Videos:** <http://mantelmount.com/install-tips>
- ▶ **Questions during installation?** Contact Customer Support Monday – Friday, 7am – 4pm PST
1.800.897.9755 x1 or support@mantelmount.com

STEP 1

Attach Braces to TV

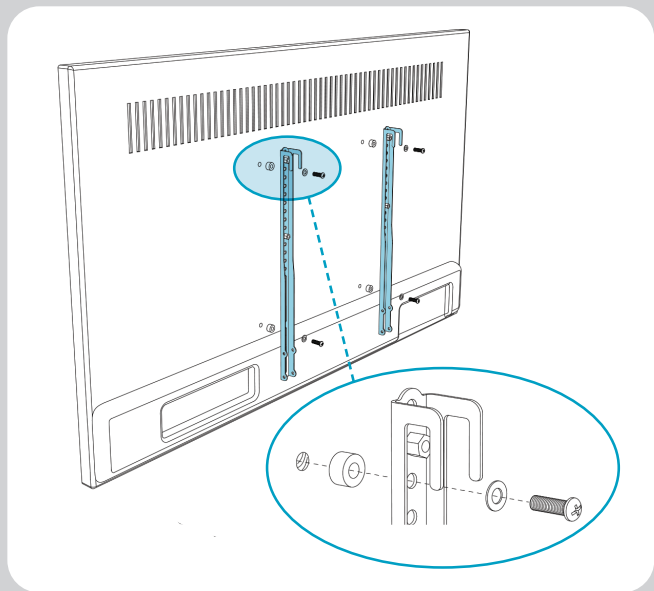

1.1 Test-fit Brace components on back of TV.

Place TV screen-side down on a flat, blanketed surface. Lay out components to check assembly configuration.

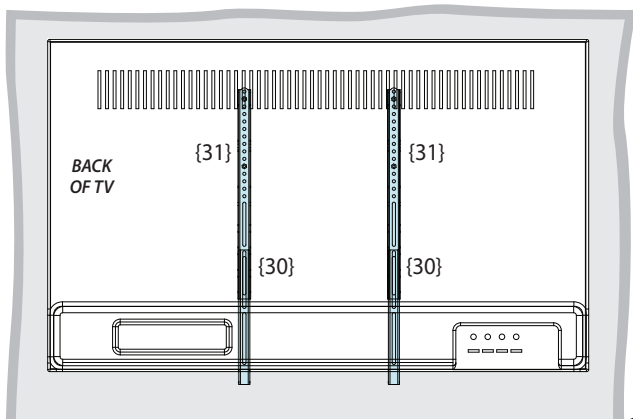

1.2 Determine if TV has a flat or irregular back.

An irregular back will require Spacers {12} and longer Screws to fill spaces between the Vertical Brace {31} and the TV. The Braces must be parallel to television screen.

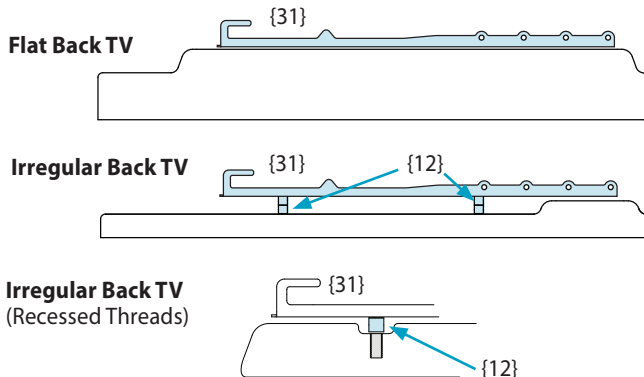

1.3 Select Screws and Spacers.

If Spacers {12} are required, choose one of these Screw combinations shown with maximum Spacer usage.

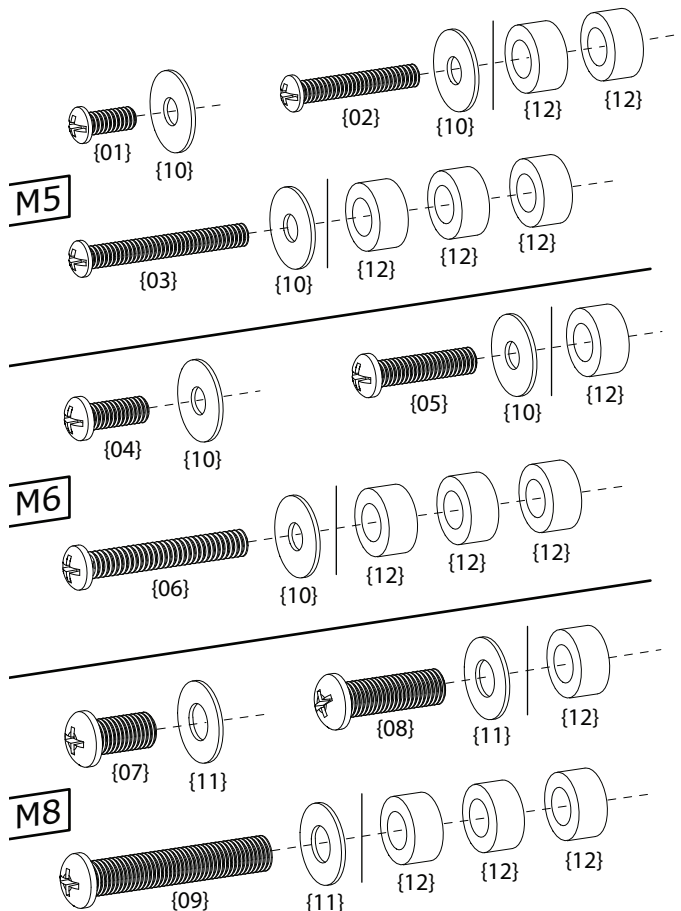

1.4 Hand-thread screw combination into the TV.

Ensure there is adequate thread engagement without hitting the bottom of threaded insert.

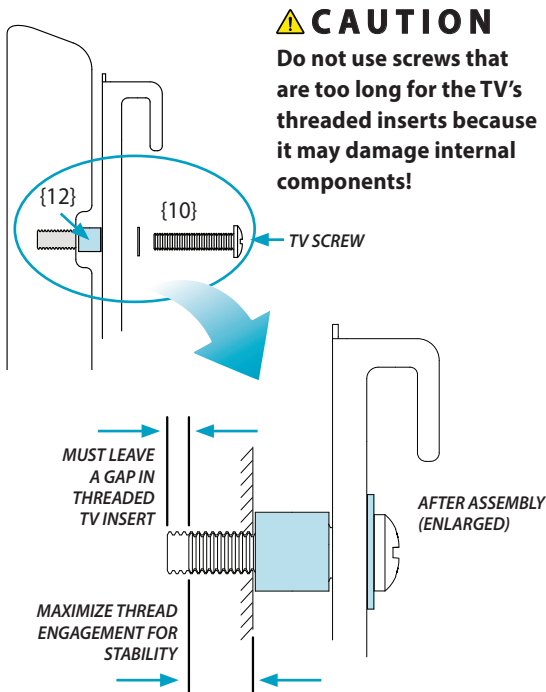

1.5 Attach the Vertical Braces to the back of TV.

Install the Vertical Braces {31} so that the bottoms of the braces are between 3" to 10" from the bottom of TV, * centering the braces vertically as much as possible.

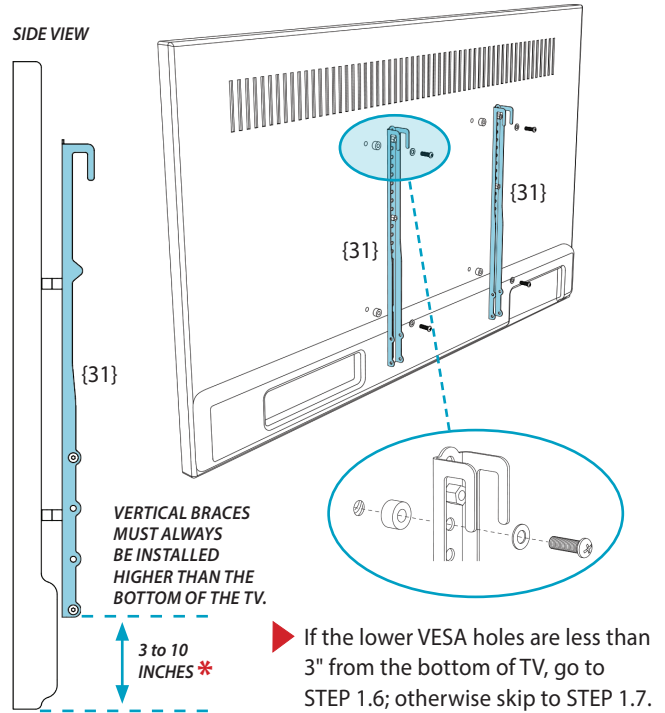

*If installing this mount with a MantelMount RB100 Recess Box, the bottom of the Vertical Brace will be 7"-10" from bottom of TV.

1.6 If the lower VESA holes are less than 3" from the bottom of the TV:

OPTIONAL

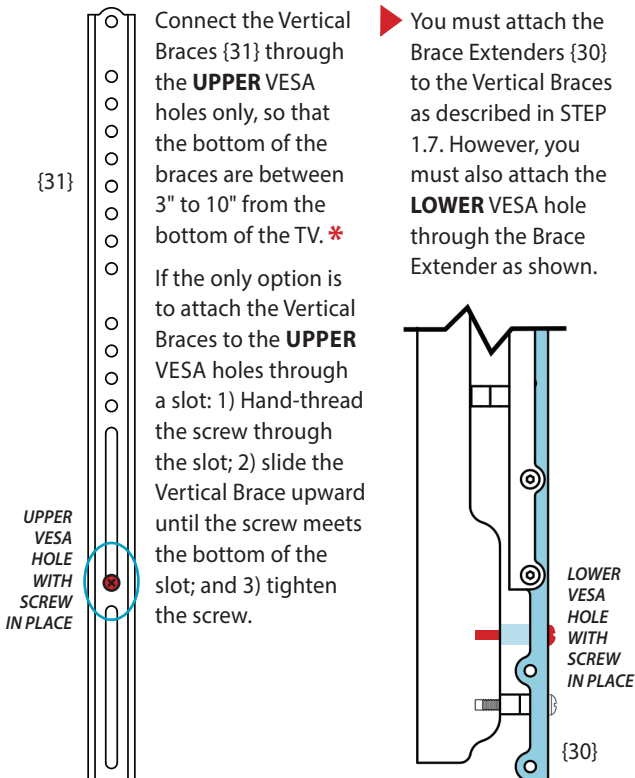

*If installing this mount with a MantelMount RB100 Recess Box, the bottom of the Vertical Brace will be 7"-10" from bottom of TV.

1.7 Attach Brace Extenders to the Vertical Braces.

Use Screws {18} and Nuts {23} to attach the Brace Extenders {30} to the Vertical Braces {31}.

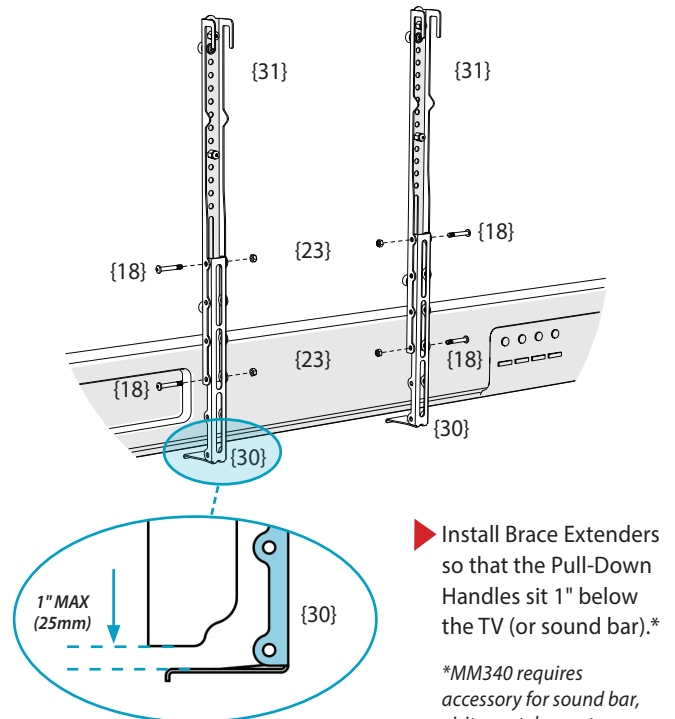

STEP 2

Determine Wall Placement

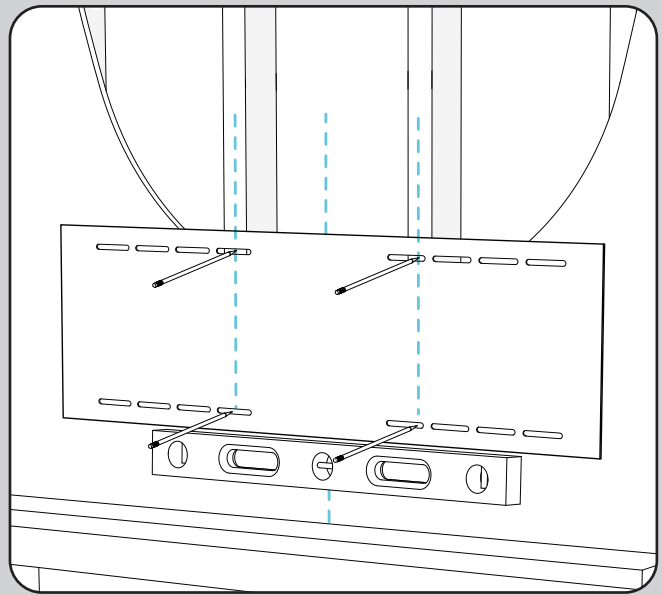

2.1

Measure the distance from the bottom of the Vertical Braces {31} (not the Extenders) to the bottom of the TV/sound bar.*

MM340 requires accessory for sound bar, visit mantelmount.com.

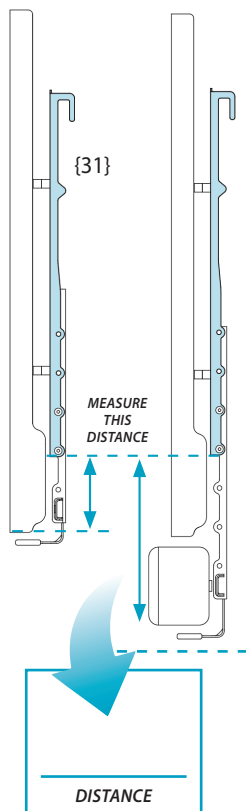

**If installing this mount with a MantelMount RB100 Recess Box, the bottom of the Vertical Brace will be 7"-10" from bottom of TV.*

2.2

Determine the minimum vertical position of the Wall Plate.*

Use the Look-up Table below to find the minimum distance between the mantel and the bottom of the Wall Plate {32}. This will be the intersection of the distance from STEP 2.1 and your mantel depth. Write the minimum distance in the box below.

DEPTH OF MANTEL →

	8" OR LESS	9"	10"	11"	12"	13"	14"	15"	16"	17"	18"
3"	3.00"	3.50	3.75	4.25	4.75	5.50	6.25	7.25	8.50	10.00	12.00
4"	4.00"	4.50	4.75	5.25	5.75	6.50	7.25	8.25	9.50	11.00	13.00
5"	5.00"	5.50	5.75	6.25	6.75	7.50	8.25	9.25	10.50	12.00	14.00
6"	6.00"	6.50	6.75	7.25	7.75	8.50	9.25	10.25	11.50	13.00	15.00
7"	7.00"	7.50	7.75	8.25	8.75	9.50	10.25	11.25	12.50	14.00	16.00
8"	8.00"	8.50	8.75	9.25	9.75	10.50	11.25	12.25	13.50	15.00	17.00
9"	9.00"	9.50	9.75	10.25	10.75	11.50	12.25	13.25	14.50	16.00	18.00
10"	10.00"	10.50	10.75	11.25	11.75	12.50	13.25	14.25	15.50	17.00	19.00

↓ DISTANCE FROM 2.1

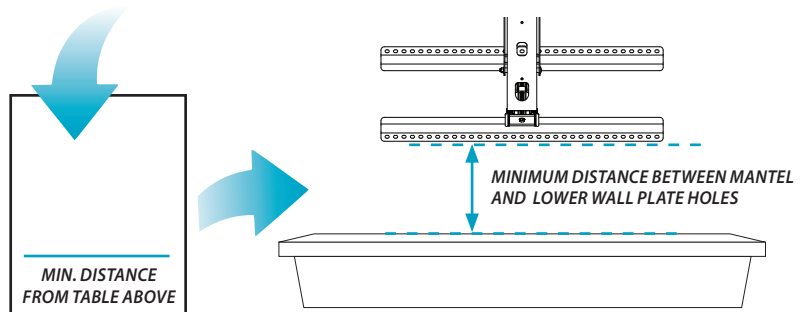

▶ Most customers want their TV mounted as close to the mantel as possible. If this describes you, go directly to STEP 2.4.

However, if you want the TV higher on the wall (such as centered between the mantel and ceiling) e.g. for extra space on the mantel for pictures or a center speaker, continue to STEP 2.3.

2.3

Determine a higher vertical position of the Wall Plate.

OPTIONAL

Some customers want the TV centered between the mantel and the ceiling or crown moulding. Others want enough space below the TV for pictures or a center speaker.

The TV's position on the wall is directly related to the placement of the lower Wall Plate. To determine exactly where to place the lower Wall Plate, choose an option below that best describes your scenario and fill in the boxes.

Option 1: I want the TV centered between the mantel and ceiling/crown moulding.

1. Record measurements already taken:

Wall Space Height (from pg. 2)

TV Height (from pg. 2)

Distance from STEP 2.1 (from pg. 8)

2. Subtract the TV Height (B) from the Wall Space Height (A), then divide by 2.

$$\frac{(A) - (B)}{2} = \text{(D)}$$

3. Add (C) and (D) to determine how many inches above the mantel to place the **lower** Wall Plate holes.

$$(C) + (D) = \text{(E)}$$

OR

Option 2: I want the TV a specific distance above the mantel.

1. Record distance from STEP 2.1 (from pg. 8)

2. Write the specific number of inches you want between the mantel and the TV (or TV with sound bar):

3. Add (C) and (D) to determine how many inches above the mantel to place the **lower** Wall Plate holes.

$$(C) + (D) = \text{(E)}$$

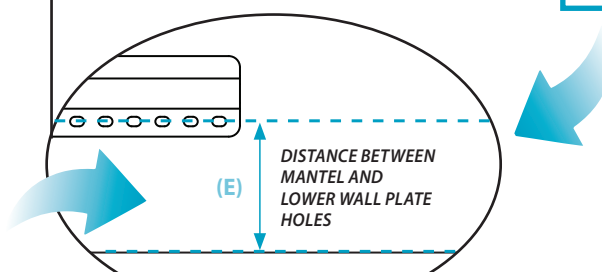

2.4

Find the center of your mantel and the centers of two studs.

Measure and mark the center line of the mantel onto the wall with tape.

Next, use a stud finder to locate two studs, one on each side of the centerline. (If you prefer to use one center stud alone, see the troubleshooting section on page 18.)

Then, at the height from either STEP 2.2 or 2.3, locate the center of the stud(s) by poking a sharp awl or finish nail through the drywall to find each stud edge. Mark these center spots on the wall. Lag Bolts must be installed into the CENTER of the studs in STEP 3.4.

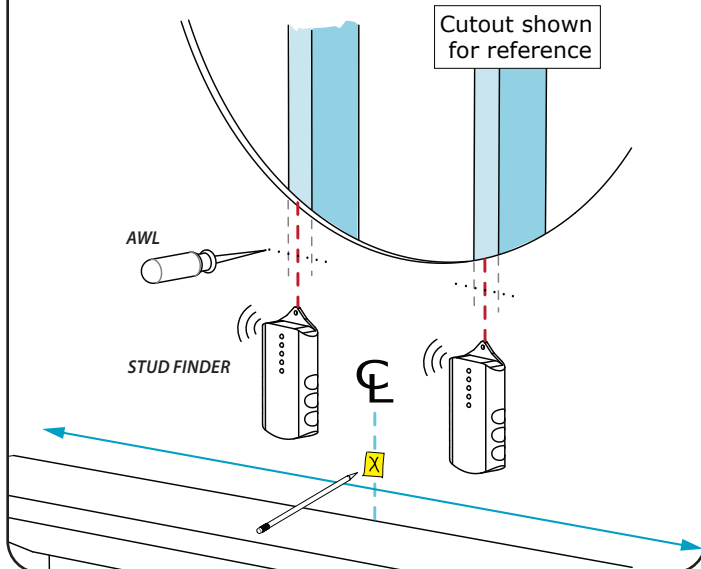

2.5

Determine the positioning of the Wall Plates.

Position the LOWER SLOTS of the Template at the appropriate distance from the mantel according to placement preferences from either STEP 2.2 or 2.3. Use a level to orient the Template.

Mark the center of the four slots along the marks for the centers of the studs. This should create a cross mark for each hole to drill.

Correctly orient a loose Wall Plate {32} to the LOWER hole markings (with slots down) and then the UPPER holes (with slots up). Determine if you can perfectly center the Wall Plate over the mantel while reaching two studs, and without interfering with a wall outlet. If there are no issues, skip to STEP 3.1. Otherwise, proceed to STEP 2.6.

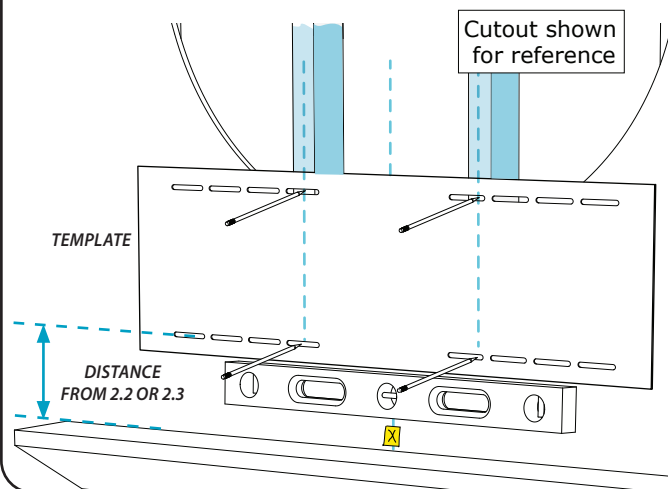

2.6

A. Slide the Wall Plates sideways on the wall until they reach two studs.

The Wall Plates {32} don't have to center-align with the Lifting Arm {35} or the mantel. As long as the Wall Plates are bolted into studs, the Lifting Arm can slide within them, allowing it (and therefore the TV) to center-align with the mantel.

Slide the Wall Plates sideways until they reach two studs, and then mark the center line of the wall onto the Wall Plates. Remember to correctly orient the Wall Plates as shown in this image and keep track of which Wall Plate is the UPPER and LOWER (don't accidentally reverse them).

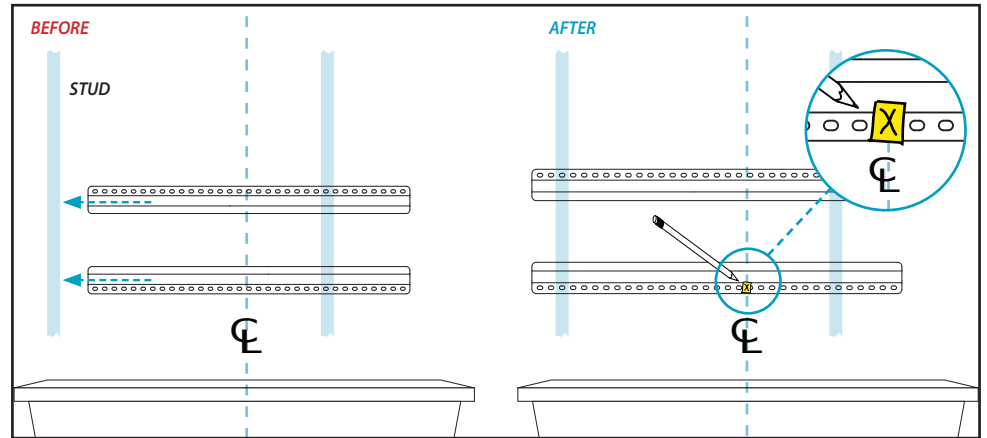

B. If necessary, move Wall Plates to clear an outlet.

▶ If a Wall Plate installation is impeded by an electrical outlet (or other) and professionally relocating the outlet is impossible, try one of these options:

- **Move Wall Plates left or right to clear the outlet.** The Lifting Arm can be attached anywhere within the Wall Plates in order to center the TV above the mantel, making it adaptable for many installation situations.

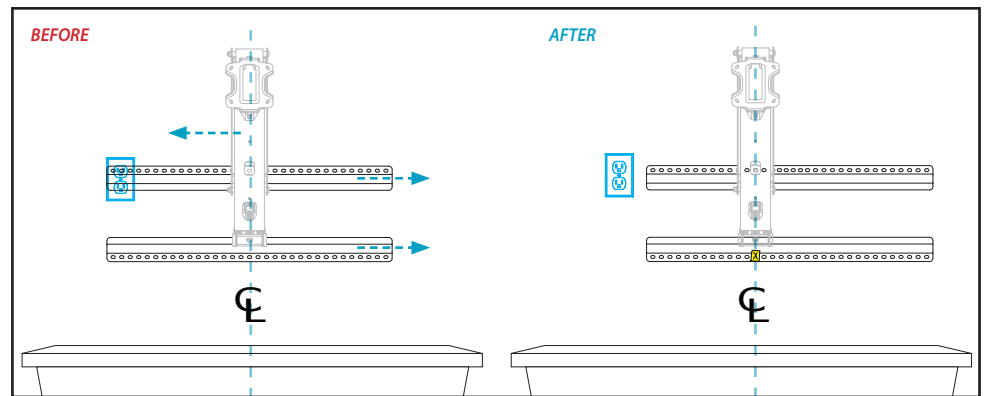

- **Move Wall Plates up or down to clear the outlet.** As long as you don't place the LOWER Wall Plate below the Minimum Distance (STEP 2.2) or above the Maximum Distance (STEP 2.3), MantelMount will still function properly.

Simply move the Wall Plates up or down enough to clear the outlet, leaving them as close as possible to the originally planned vertical positions.

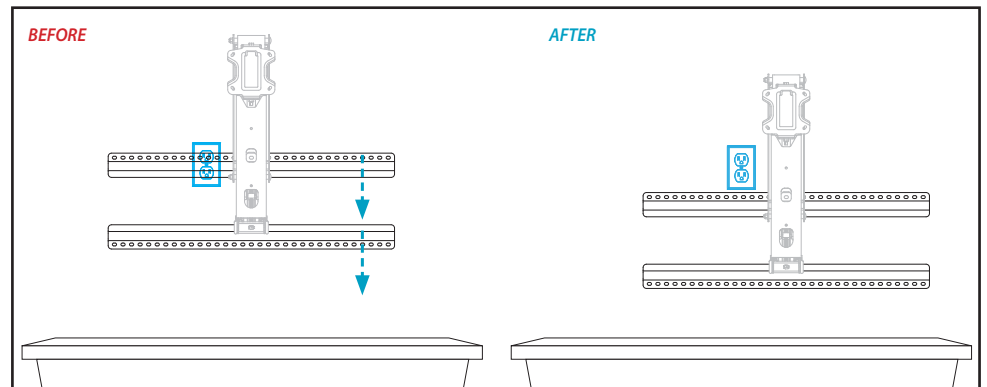

Next, move the Vertical Braces {31} on the back of the TV using the same number of inches used to move the Wall Plates (e.g., move the Vertical Braces up 2" if the Wall Plates were moved up by 2"). The bottom of the Vertical Braces must remain between 3 to 10 inches from the bottom of the TV.

If outlet is directly behind the Lifting Arm, the only solution is to move the Wall Plates up.

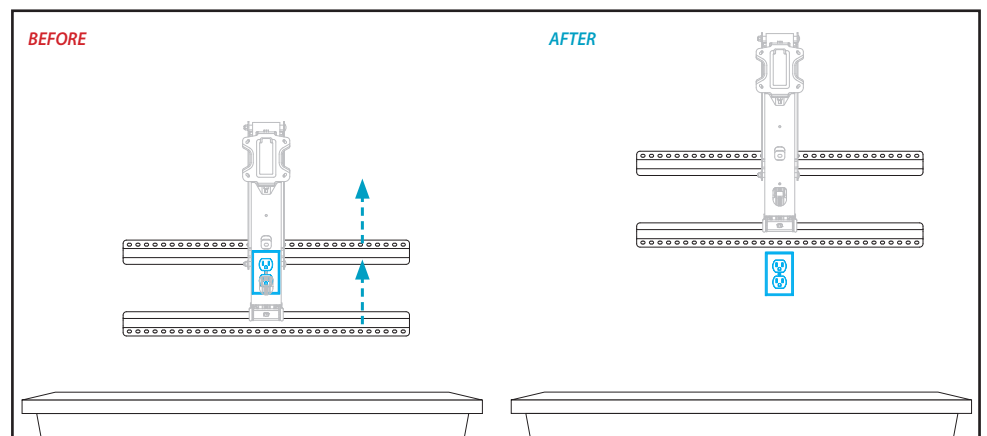

STEP 3

Attach Mount to Wall

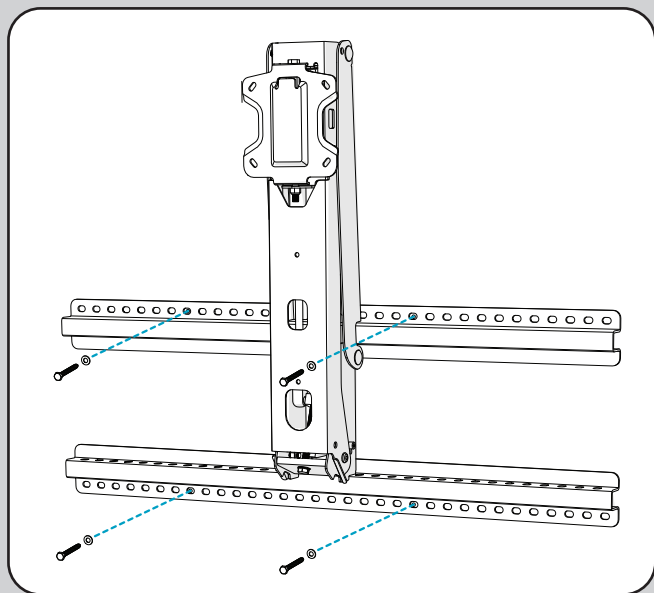

3.1 Attach Lifting Arm to Wall Plates.

If you arrived from STEP 2.5 then you can attach the Lifting Arm {35} directly to the centers of the Wall Plates {32}.

If you arrived from STEP 2.6 then you must align the center of the Lifting Arm to the marks on the Wall Plates, while orienting the Upper and Lower Wall Plate correctly.

Install four bolts {14} through the back channels of the Wall Plates into the threaded holes of the Lifting Arm. Tighten securely.

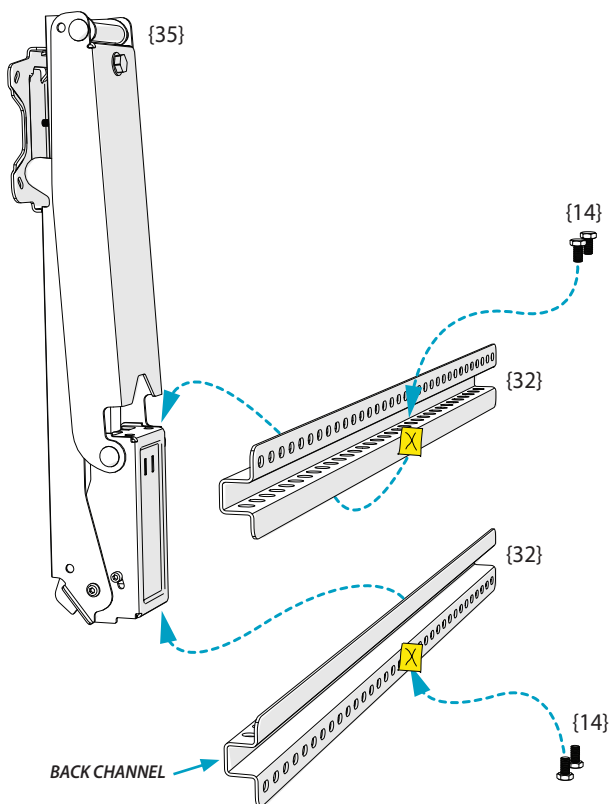

3.2 Verify positioning of the mount with stud(s).

Align the mount to the LOWER marked spots on the wall and verify that the markings for the two UPPER hole locations are accurate. Fine tune the upper marks if necessary.

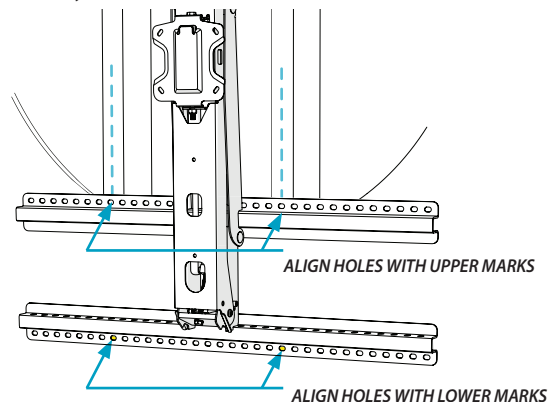

i If the Lifting Arm is blocking a Wall Plate hole you need to access:

Move the Wall Plates {32} to the left or right of the desired position and temporarily install it. Use four Lag Bolts {17} to secure the Wall Plates to the studs. This will allow you to pull the Lifting Arm {35} down and install the Safety Bolt (see STEP 4.1) in order to access the blocked Wall Plate hole.

Then, remove Lag Bolts and reinstall the mount in the desired position.

For assistance, contact Customer Support.

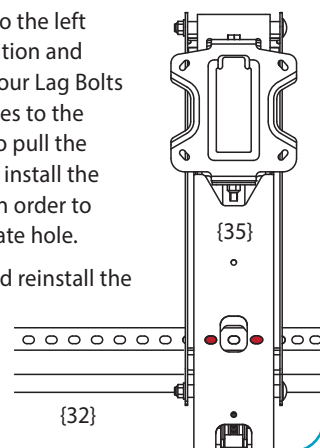

3.3

Drill four pilot holes.

Use a 7/32" drill bit to create a depth of 2.5" (65mm), including wall covering.

- ▶ **Wall covering (drywall) must not exceed a thickness of 5/8".**

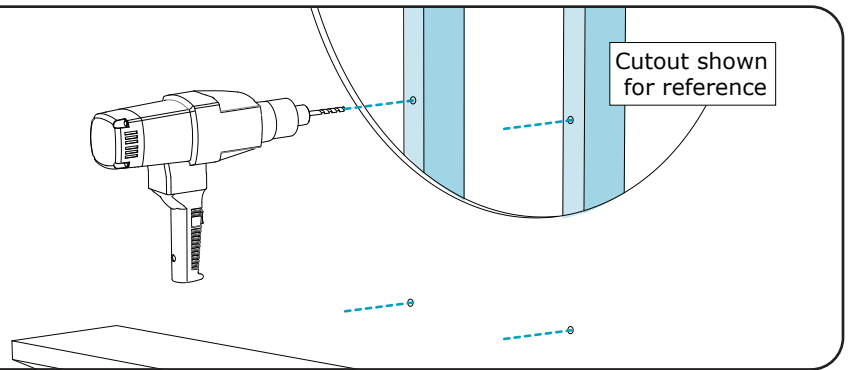

3.4

Attach the Wall Plates and Lifting Arm (referred to as the "mount" from this step forward) onto the wall.

Install Lag Bolts {17} and Washers {11} through the Wall Plate {32} holes, directly into the center of the studs, using the pilot holes drilled in STEP 3.3.

⚠ WARNING

Do not over-tighten Lag Bolts, it can cause property damage or injury. Tighten only until the washers are firmly against the Wall Plate.

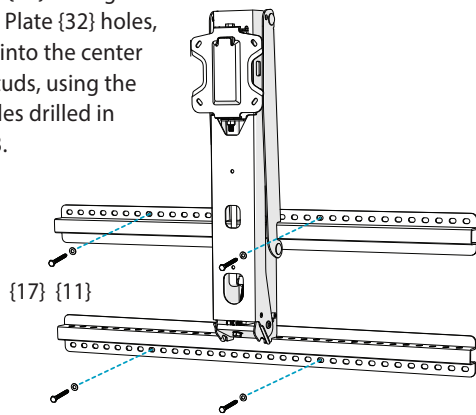

3.5

Insert Cable Tie Anchors into Lifting Arm.

Insert two Cable Tie Anchors {22} into the front holes on the lower part of the Lifting Arm {35}. Press firmly until flat.

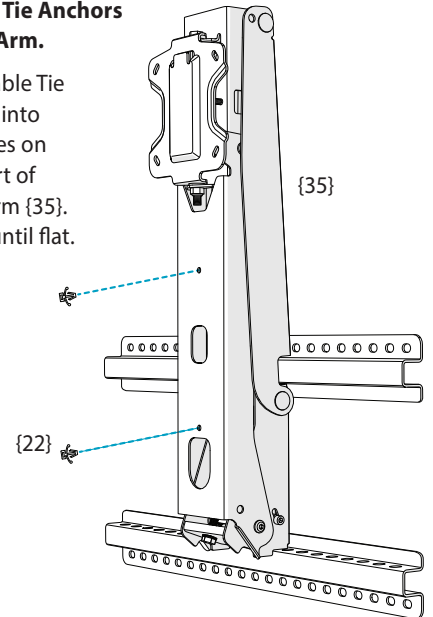

3.6

Use the included Cable Ties to attach cables.

Ensure Cable Ties {24} are sideways to the lower part of the Lifting Arm {35}, making a gentle loop. The figure below illustrates the recommended way to attach cables.

- ▶ Cables must be long enough to accommodate the extension and swivel of the mount. Check all ranges of motion before tightening the Cable Ties.

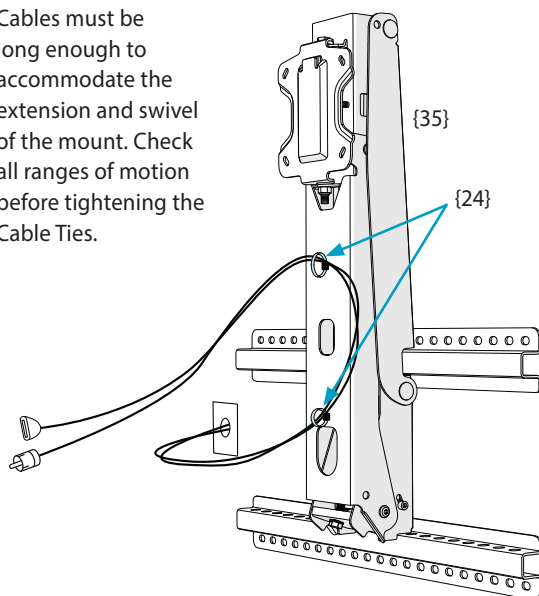

3.7

Attach the TV Brace to the Lifting Arm.

Hang the TV Brace {33} onto the Lifting Arm {35} and make sure it's level when tightening the four Leveling Screws {15}.

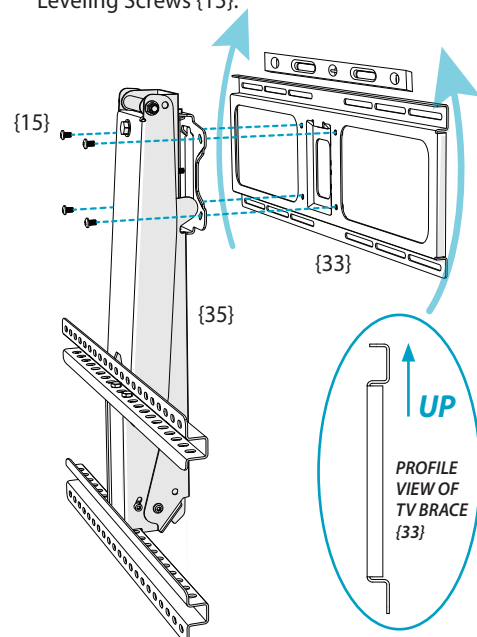

STEP 4

Attach TV to Mount

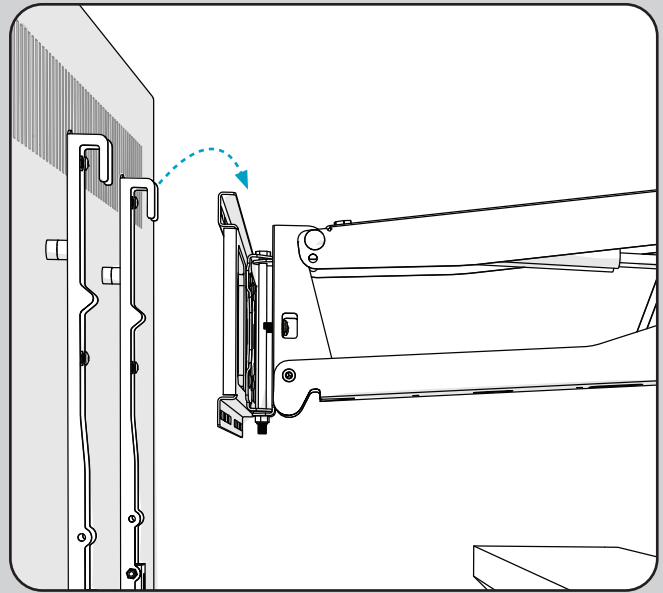

⚠ CAUTION

Do not damage or scratch the rods of the Gas Springs while performing these steps!

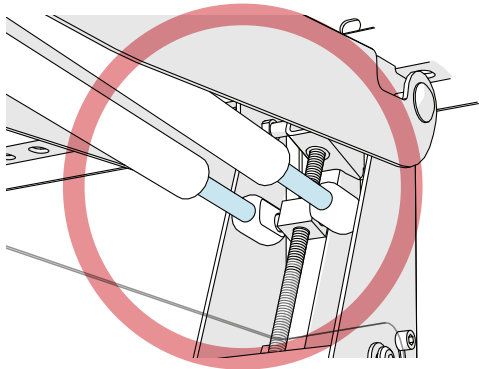

⚠ WARNING

Do not put hands into Lifting Arm without the Safety Bolt and Safety Nut installed. The force of the Lifting Arm can cause bodily injury!

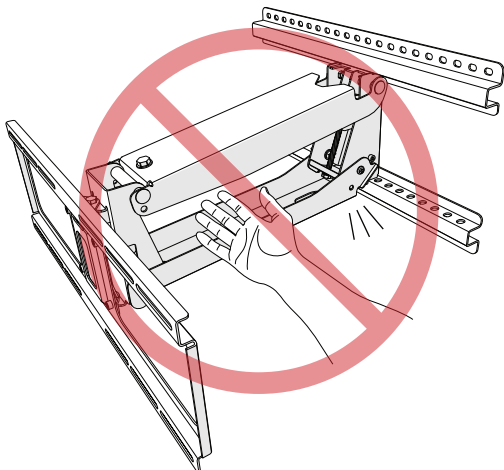

4.1

Insert the Safety Bolt and Safety Nut.



Use your body weight to firmly pull down the TV Brace {33} until the Lifting Arm {35} is horizontal to the floor. Continue holding onto the TV Brace.

- ▶ A second person must insert the Safety Bolt {20} through the Safety Hole in the base of the Lifting Arm and install the Safety Nut {27}.

Slowly release the TV Brace until the Lifting Arm gently comes to rest against the Safety Bolt. The Lifting Arm should remain in a horizontal position during installation. You will later remove the Safety Bolt in STEP 5.4.

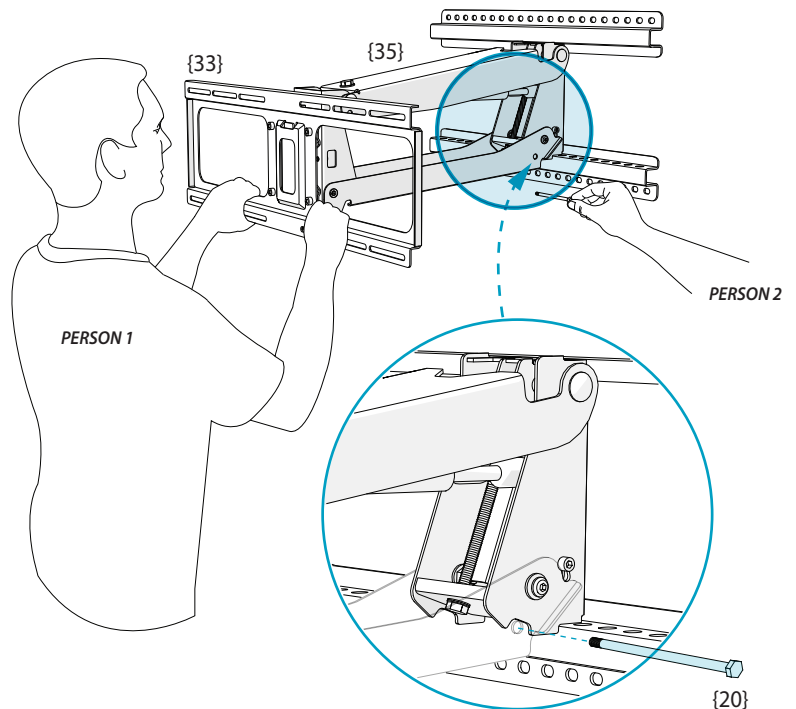

4.2

Carefully hang the TV on the TV Brace.

Make sure that all the hooks on the Vertical Braces {31} engage the TV Brace {33}.

- ▶ If the Lifting Arm {35} appears to be too close to the mantle, remove the TV. Refer to STEP 5.3 and make an adjustment to the Bottom Stop positions. Repeat this process until the Lifting Arm is a safe distance from the mantle when the TV is installed.

 Do not allow the TV to drop far enough to cause the Lifting Arm to hit the mantle.

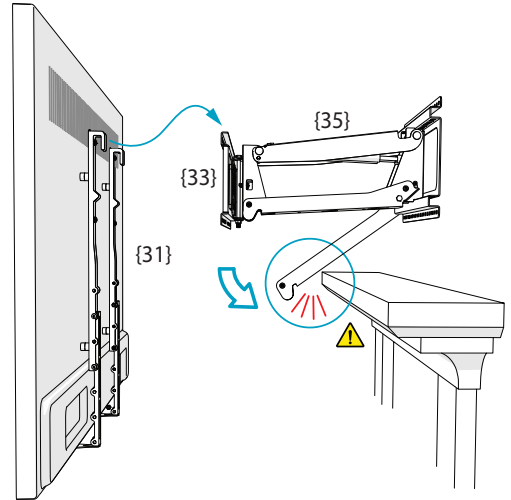

4.3

Center and level the TV on the TV Brace.

Make sure the center of the brace is aligned with the center of the TV before leveling. Move on to STEP 4.4 once the TV is level.

If the TV sags to one side, carefully slide it sideways in the opposite direction up to a MAXIMUM of 2 inches, until it levels.

- ▶ If the TV is now level but appears noticeably off-center above the mantle, remove the TV and relocate the Wall Plates {32} an equal distance in the opposite direction to compensate. Repeat STEPS 3.3 and 3.4.
- ▶ If you experience additional issues leveling the TV, refer to "TV Leveling" in the Troubleshooting Tips on page 18.

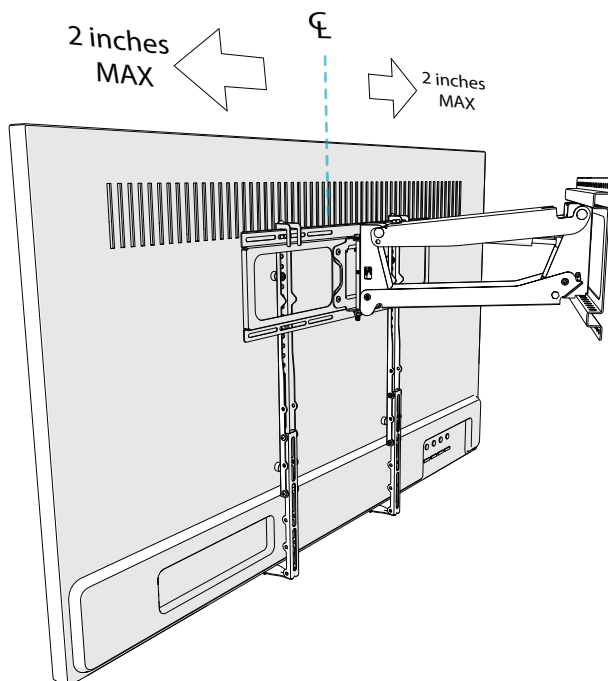

4.4

Attach the TV Brace to the Vertical Braces.

Install four Screws {15} through the TV Brace {33} and into the Vertical Braces {31}.

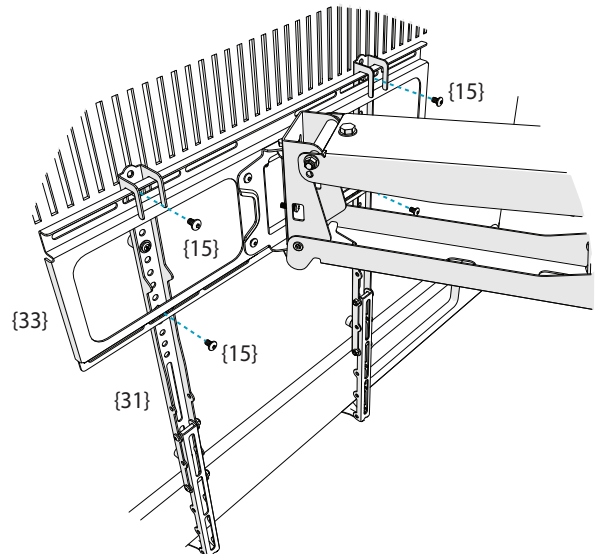

4.5

Attach the electrical and signal cables to the TV.

Give cable segments extra length so that they are not stressed or kinked when the mount moves.

- ▶ Ensure that cables do not get pinched within the Lifting Arm when the TV is raised.

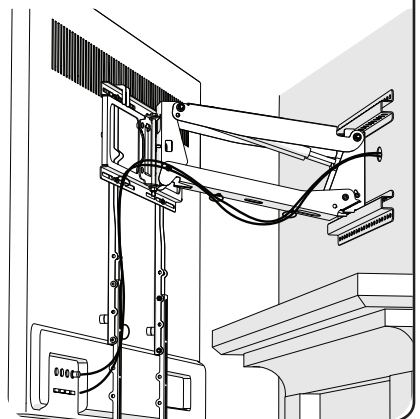

STEP 5

Make Final Adjustments

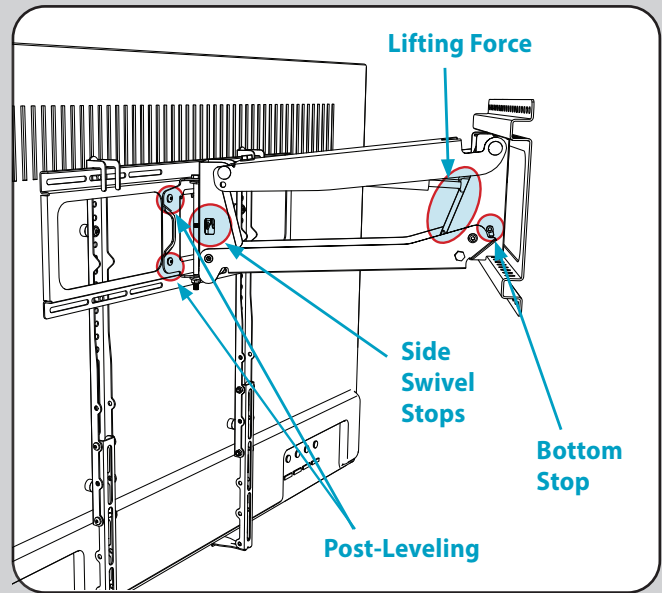

5.1

Adjust the Lifting Force for the TV.

First, review all the images in this step.

With Safety Bolt {20} in place, use a 10–14mm socket wrench with an extension to adjust the Tension Bolt {41} (the long bolt inside the Lifting Arm {35}).

For heavy TVs, turn the Tension Bolt clockwise in order to pull the Gas Springs {38} DOWN and increase the lifting force. Turn counterclockwise for lighter TVs.

- ▶ The Gas Springs move slowly as you turn the Tension Bolt. Their movement is subtle. **Please be patient as it may take multiple revolutions to reach the desired tension.**

Adjust the Tension Bolt until the TV gently stays in the lowered position. Move the TV up and down within the range below the Safety Bolt. The TV should almost stay up against the Safety Bolt and slowly lower to the Bottom Stops when released.

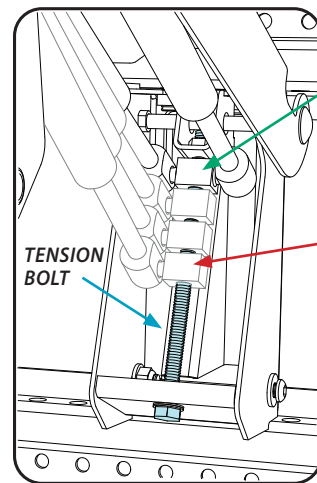
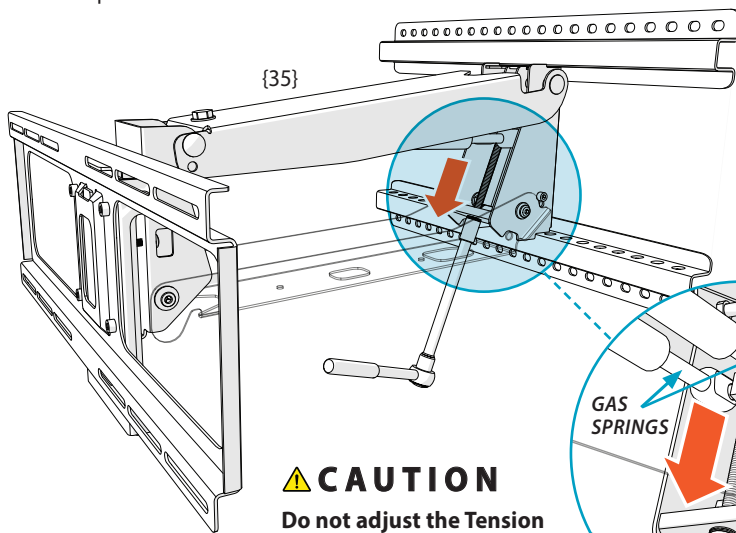

⚠ CAUTION
Do not adjust the Tension Bolt all the way to the bottom – your mount won't function properly in that position.

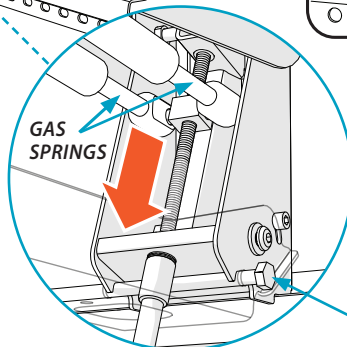

5.2 Adjust the Side Swivel Stop positions, if necessary.

To keep your TV from bumping the mantel or wall, loosen the Locknuts {23} and adjust the Swivel Stop Screws to the desired stopping left and right positions.

Tighten both Locknuts after the adjustments are made.

- ▶ If no swivel is desired, it may be necessary to remove the Locknuts and reattach them on the other side of the Swivel Bracket so that the Screws can be threaded out to their maximum length.

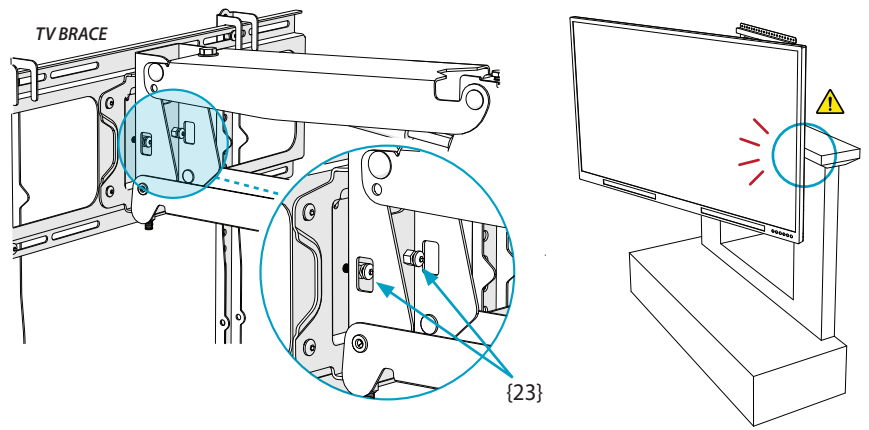

5.3 Adjust the Bottom Stop positions and level the TV, if necessary.

To keep the TV from hitting the top of the mantel or dropping too low, adjust the Bottom Stop screws on each side of the Lifting Arm {35}.

Loosen the Locknuts {23} and adjust the Bottom Stop screws to the desired stopping position, and tighten the Locknuts.

Next, place a level on top of the TV. If the TV is not level in the DOWN position, adjust one of the bottom stop screws until the TV is level.

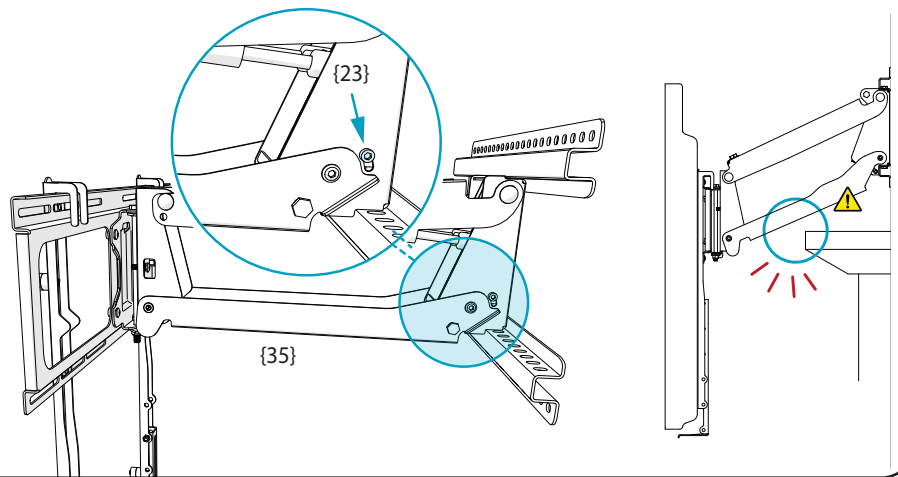

5.4 Remove the Safety Bolt and Safety Nut.

Store these parts for future use. The Safety Bolt {20} and Safety Nut {27} are needed to remove the TV at any time in the future.

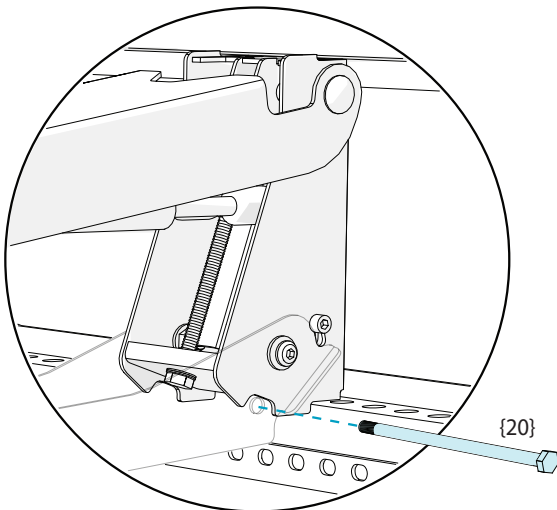

▶ **STORE SAFETY BOLT FOR FUTURE USE!**

⚠ WARNING

Never release the handle before the TV mount is fully upright. (Don't let it slam up!) MantelMount is strongest in the top position, and allowing it to slam closed can damage televisions. Always control the lifting process.

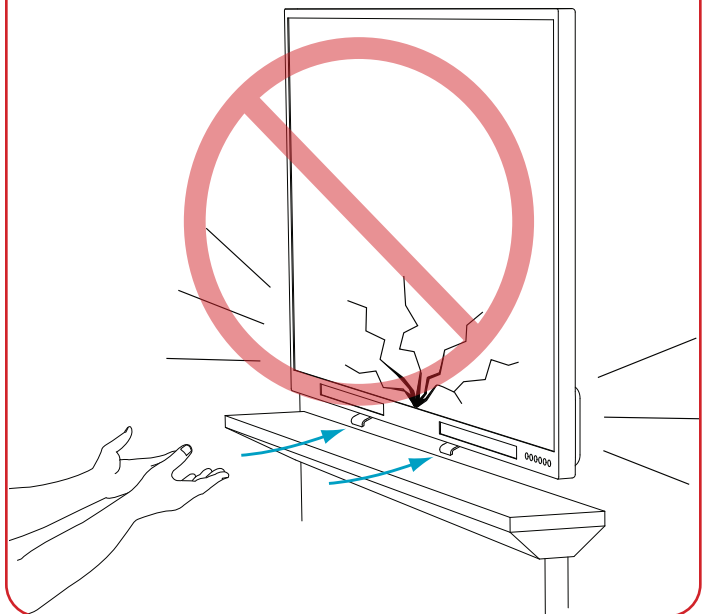

5.5 Verify the proper Lifting Performance (Force).

MantelMount is designed to keep the TV securely in the UP position while also allowing it to gently rest in the DOWN position. Refer to diagram below.

If you need to make adjustments, reinsert the Safety Bolt and then repeat STEP 5.1.

- ▶ For more information on refining Lifting Performance, refer to "Mount Performance" in the Troubleshooting Tips on page 17.

Strongest in the UP/TOP position

Neutral in the MID positions

Weakest in the DOWN/BOTTOM position

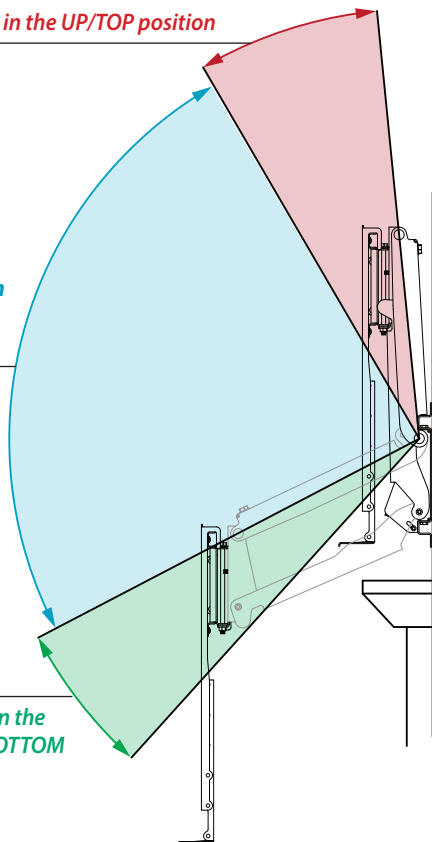

5.6 Make Post-Leveling adjustments, if necessary.

Place a level on top of the TV while it's in the UP position. If it's level, the installation is complete! If not, slightly loosen all four Leveling Screws {15} and rotate the TV until it's level and then tighten all the Screws.

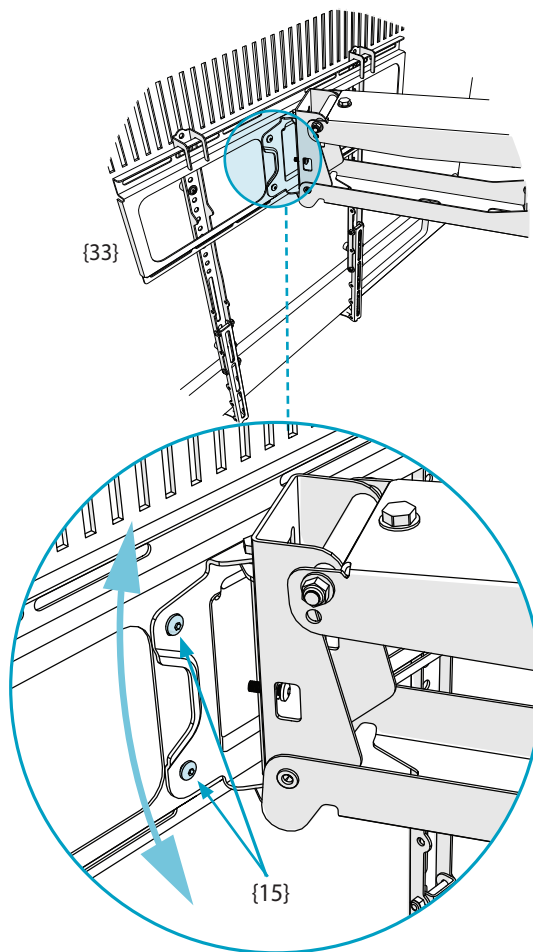

Thank you for purchasing a MantelMount.



For installation assistance, refer to the Troubleshooting Tips or contact Customer Support.

1.800.897.9755 ext.1
support@mantelmount.com

Monday – Friday
7:00am – 4:00pm PST

TROUBLESHOOTING TIPS

Customer satisfaction is our top priority!

Following are solutions for the most common installation challenges. For further assistance, visit www.mantelmount.com/troubleshooting or contact Customer Support at 1-800-897-9755 ext.1 or support@mantelmount.com, Monday through Friday, 7am to 4pm PST.

NOTE: In rare cases, one troubleshooting adjustment may create the need for another. Be prepared for some trial and error.

MOUNT SPACE	
ISSUE	SOLUTION
The wall covering is made of brick or stone.	It's possible to install MantelMount by using concrete anchors (included) with the Lag Bolts {17}, PROVIDED the brick/stone/wall is structurally sound, several inches thick, and can handle four times the weight of the TV and mount. Working with a concrete/masonry professional for this type of installation is recommended.
The drywall/stucco wall covering is thicker than 5/8".	Please contact Customer Support for guidance before attempting installation.
A single wood stud is centered on my wall.	It's OK to mount the Wall Plates to a single stud by driving two Lag Bolts through the center of the Wall Plates and into the center stud, as long as the Lifting Arm ends up positioned directly in front of the stud. Alternatively, for a smaller footprint, replace the Wall Plates with the SSB40 Single Stud Adapter, available at MantelMount.com .
MOUNT PERFORMANCE	
ISSUE	SOLUTION (May require some trial and error to reach optimal performance.)
The Lifting Arm won't pull down in order to insert the Safety Bolt.	It will take some force to pull down the Lifting Arm when it's in the raised position and there is no TV attached. As long as the mount is securely attached to a stud(s) in the wall, it won't break. First, make sure the TV Brace is attached to the Lifting Arm (see Step 3.7). Next, pull the Lifting Arm down: Stand in front of the mount, reach up and grasp the top or bottom of the TV Brace with both hands, palms facing down. Move one foot back for leverage and straighten elbows. Then lean back, bend both knees and elbows, and pull the mount out and down (see Step 4.1).
TV is difficult to pull down.	Use the <i>MantelMount Three-Step Pull-Down Technique</i> : <ol style="list-style-type: none"> 1. Stand in front of the mount, arms extended with palms up and elbows straight. 2. Firmly grasp the lifting handles and lean back slightly with one foot forward and one foot back. 3. Step backward with forward foot to pull the mount away from the wall while placing downward pressure on the handles (keep elbows extended). <p>If the mount is still difficult to pull down, review Step 5.1, make slight counterclockwise adjustments to the Lifting Force, and try again. The goal is to adjust the Lifting Force just enough to comfortably pull the TV down without overcompensating. If it becomes too easy to pull down, it may also become difficult to lift up. Give it a few practice runs, but be prepared for a little trial and error.</p>
TV is difficult to lift up.	If the mount is relatively easy to pull down, slightly tighten it when it's in the UP position. Review Step 5.1 to make minor clockwise adjustments to the Lifting Force, then try lifting up the TV again. The goal is to adjust the Lifting Force just enough to comfortably lift the TV without too much effort. However, if it becomes too easy to lift up, it may become difficult to pull down. If you are unable to find a balance between ease of pulling down and lifting up, follow the instructions above and focus primarily on making it easier to pull down. Then make adjustments to the Bottom Stop positions (see Step 5.3). Lower the Bottom Stops to limit downward travel. The less downward travel, the easier it will be to lift.
The mount won't remain stationary anywhere along the route of travel.	Make adjustments to the Lifting Force (see Step 5.1). The combination of the TV's size and weight, installation height and mantel depth may affect whether the TV can rest at various positions along the route of travel. What's most important is that the TV can comfortably pull down/lift up and stop at the optimal viewing height.
TV is not lowering the full vertical travel listed in the specifications.	If you can comfortably pull down and lift the TV but would like for it to drop below the lowest Bottom Stop Position, remove the Bottom Stop Screws on each side (see Step 5.3); the TV will travel even lower. However, proceed with caution. If the TV is above a mantel, removing the Bottom Stop Screws may cause the Lifting Arm to hit the top of the mantel.

CONTINUED ON NEXT PAGE →

TROUBLESHOOTING TIPS

← CONTINUED FROM PREVIOUS PAGE

MOUNT PERFORMANCE

ISSUE	SOLUTION (May require some trial and error to reach optimal performance.)
TV is tilting forward when in the UP position.	This is generally an indication that the Lifting Force is not set tight enough in the UP position (see Step 5.1). Slightly turn the Tension Bolt clockwise and try again. The goal is to adjust the Lifting Force just enough for the TV to no longer tilt in the UP position. Be careful not to set the Lifting Force too tightly in UP position or the TV may not fully lower to the optimal viewing position.

TV LEVELING

ISSUE	POSSIBLE CAUSE	HOW TO CHECK	SOLUTION
TV is not level in the UP and/or DOWN positions.	The mantel, ceiling or floor may not be level.	Compare TV level with that of the mantel and floor.	<ol style="list-style-type: none"> 1. Adjust until visibly satisfactory. 2. Pull down the TV. 3. Make Post Leveling adjustments (Step 5.6) and match the level readings of the mantel with the TV. 4. Make additional adjustments as shown in Step 4.3 and Step 5.3 if needed.
	Vertical Braces aren't evenly attached.	Look at the back of the TV and ensure that the top of the Vertical Braces are parallel to one another.	<ol style="list-style-type: none"> 1. Insert the Safety Bolt and Safety Nut (Step 4.1). 2. Detach the TV Brace from the Vertical Braces (Step 4.4). 3. Remove electrical and signal cables (Step 4.5). 4. Remove the TV from the TV Brace (Step 4.2) and lay TV face down on a blanketed surface (Step 1.1). 5. Remove the Vertical Brace(s) as necessary. 6. Reposition the Vertical Braces so that they are properly parallel to one another, then repeat Step 1, Step 4 and if necessary, Step 5.
	Wall Plates aren't level.	Use a level on top of Wall Plates to verify that it's not level.	<ol style="list-style-type: none"> 1. Insert the Safety Bolt and Safety Nut (Step 4.1). 2. Detach TV Brace from Vertical Braces (Step 4.4). 3. Remove electrical and signal cables (Step 4.5). 4. Remove the TV from the TV Brace (Step 4.2) and lay TV face down on a blanketed surface (Step 1.1). 5. Slightly loosen all four Lag Bolts (Step 3.4). 6. Adjust Wall Plates so that they are level. 7. Hold Wall Plates in level position and firmly tighten the four Lag Bolts. Heed warning in Step 3.4. 8. Once the Wall Plates are level, repeat Steps 3, 4 and 5.
TV is level in the UP position, but unlevelled in the DOWN position.	The Bottom Stops aren't evenly set.	Use a level to verify the TV is level in the UP position but not in the DOWN position.	Follow the instructions in Step 5.3 . Be prepared for some trial and error. If adjusting the Bottom Stops doesn't solve the problem, try the solution below for when a TV is heavier on one side.
	TV is heavier on one side.	Use a level to verify the TV is level in the UP position but not in the DOWN position.	Attach a counterweight to the back of the TV. Contact Customer Support for assistance.
TV is level in the DOWN position, but unlevelled in the UP position.	Post-Leveling Adjustments haven't been made.	Use a level on top of the TV to verify it's leveled in the DOWN position but not in the UP position.	Refer to Step 5.6 and make adjustments.

MM340 SPECIFICATIONS

- TV Weight Capacity: 20–90 pounds
- TV Screen Size: 44" – 80" diagonal
- Maximum Lowering Distance: 27"
- Thickness from Wall: 5.5"
- Mount Weight: 25 lbs.
- Steel Thickness: 2.5mm
- Swivel: 30° Left and 30° Right
- VESA Pattern 600w x 600h
- Dimensions: 26"w x 25.2"h x 7.25"d

Front View

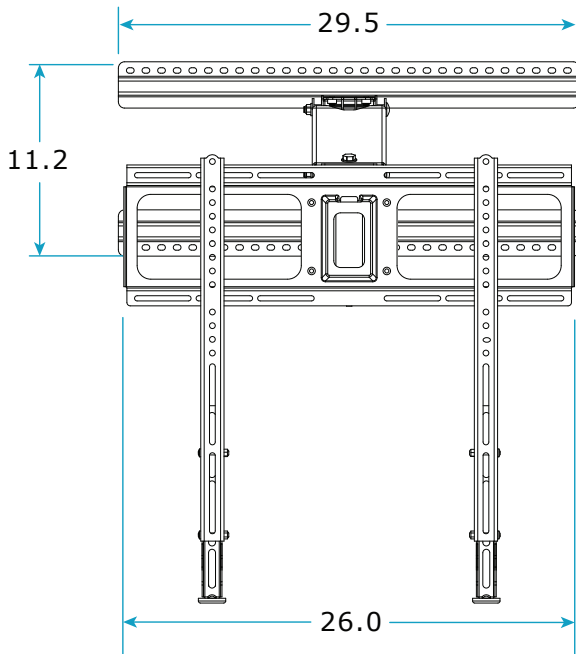

Profile

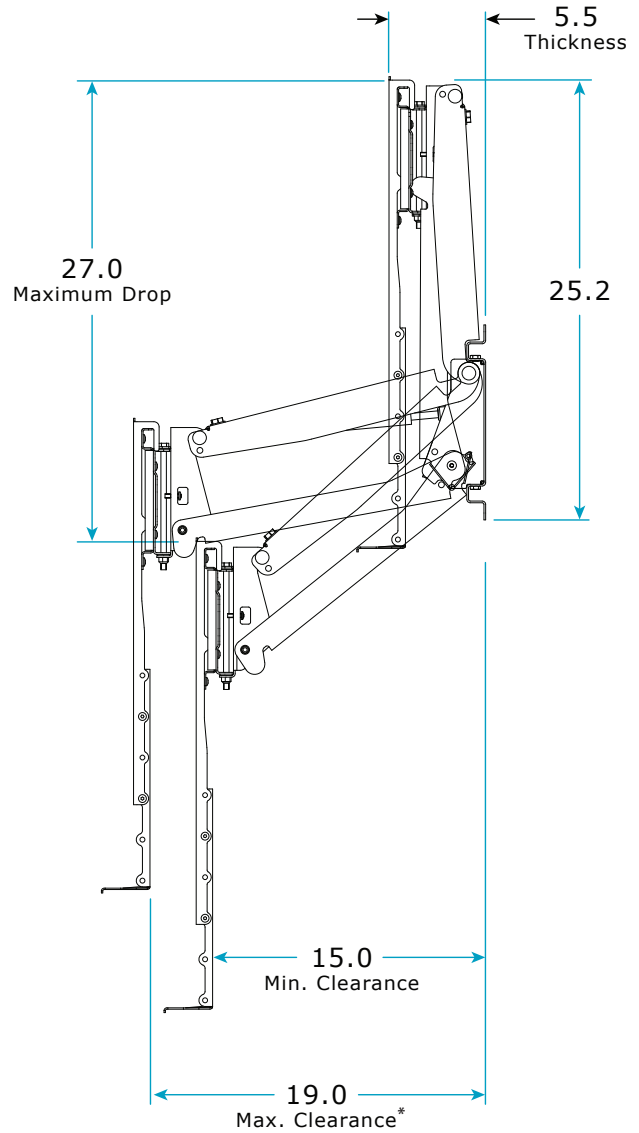

Overhead View

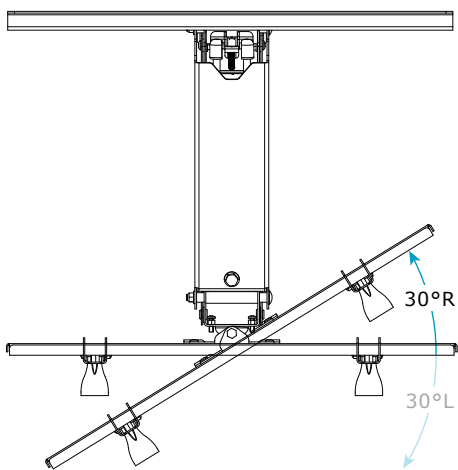

** Although the MM340 can technically clear a 19" mantel, it will reduce the vertical travel distance. Therefore, MantelMount recommends a mantel depth of 18" or less.*



U.S. Pat. No. 8,864,092

For more information on MantelMount patented technology visit: www.mantelmount.com/pages/patents

Limited Lifetime Warranty: MantelMount will replace or repair any product or part that proves defective due to improper workmanship or material during the warranty period. Go to <https://www.mantelmount.com/pages/limited-lifetime-warranty> for details.



For missing/damaged parts or questions during installation,
please contact our Customer Support team at **1.800.897.9755 ext.1**
or **support@mantelmount.com**. Customer satisfaction is our highest priority!

U.S. Pat. No. 8,864,092 - For more information on MantelMount patented technology visit: www.mantelmount.com/pages/patents

MAILING ADDRESS: 2647 Gateway Road Ste. 105-435 Carlsbad, CA 92009
mantelmount.com

© 2020 MANEHU PRODUCT ALLIANCE, LLC

MM340 - 01-27-23