INSTRUCTION MANUALS

Tensioned Advantage® Series



Table of Contents

Tensioned Advantage® (With Closure Door)

Previously Named: Tensioned Advantage Deluxe Electrol

Tensioned Advantage

Previously Named: Tensioned Advantage Electrol

Tensioned Advantage (Over 14' W with Closure Door)

Previously Named: Tensioned Large Advantage Deluxe Electrol

Tensioned Advantage (Over 14' W)

Previously Named: Tensioned Large Advantage Electrol

Tensioned Advantage (Featuring ViewShare Technology)

Previously Named: ViewShare Tensioned Advantage Electrol



INSTRUCTION MANUAL

Tensioned Advantage®
(With Closure Door)



Original Instructions

Disclaimer

Legrand AV Inc. and its affiliated companies and subsidiaries (collectively, "Legrand AV"), intend to make this manual accurate and complete. However, Legrand AV makes no claim that the information contained herein covers all details, conditions or variations, nor does it provide for every possible contingency in connection with the installation or use of the products described herein. The content herein is subject to change without notice or obligation of any kind. To the maximum extent permitted by applicable law, Legrand AV makes no representation or warranty, expressed or implied, regarding the information contained herein. Furthermore, Legrand AV assumes no responsibility for accuracy, completeness or sufficiency of the information contained in this document.

Da-Lite® is a registered trademark of Legrand AV. All rights reserved.

Important Safety Instructions

When using your video equipment, basic safety precautions should always be followed, including the following:

1. Read and understand all instructions before using.
2. Position the cord so that it will not be tripped over, pulled, or contact hot surfaces.
3. If an extension cord is necessary, a cord with a current rating at least equal to that of the appliance should be used. Cords rated for less amperage than the appliance may overheat.
4. To reduce the risk of electric shock, do not disassemble this appliance. Contact an authorized service dealer when repair work is required. Incorrect reassembly can cause electric shock when the appliance is used subsequently.
5. The use of an accessory attachment not recommended by the manufacturer may cause a risk of fire, electric shock, or injury to persons.
6. Failure to provide adequate structural strength for this component can result in serious personal injury or damage to equipment! It is the installer's responsibility to make sure the structure to which this component is attached can support the weight of all equipment. Reinforce the structure as required before installing the component.
7. Use this projection screen only for its intended use as described in these instructions. Do not use attachments not recommended by the manufacturer.

Save These Instructions

Pre-Installation

1. Carefully unpack screen and remove outer wrapping from case.
2. Make sure to recheck measurements of screen location before installation.

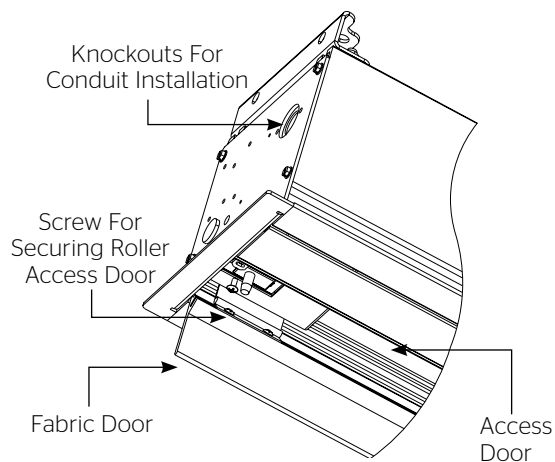

Figure 1

Case Installation

1. The case provides multiple attachment points for bolts, cables, or threaded rod. Page 7 shows threaded rod installed. The variable position-mounting bracket may be located anywhere along the length of the case. It is recommended to keep the brackets spaced evenly enough to distribute the weight of the screen.

The case has a self-trimming flange around the bottom. Ceiling tiles or drywall may be placed on top of this flange to provide a finished appearance.

2. After securing the case in the ceiling check that the case is level and plumb.
3. Use supplied 1/8" hex key and a 1/4" wrench to remove silver shipping brackets attached to slat and screen case.
4. Install electrical connections that apply to your unit. Refer to the following diagrams for proper installation. The diagrams on page 6 are for standard controls; the diagrams on page 7 are for SCB100 controls and page 8 for SCB200 controls. The terminal block for the wall switch connections is located under the metal housing surrounding the junction box. Remove two screws for access.

NOTE: Use provided knockouts for all electrical connections. DO NOT drill additional holes into screen case or end cap.

Screen And Roller Assembly Installation

If your screen was shipped with the motor and roller already installed proceed to step 6.

1. Remove the screw from each end of the access door (front door) and open the door. See figure 1.
2. Carefully unpack screen and roller assembly. Leave packing paper on the roller.
3. Place the roller assembly into the case with the motor on the left side. The limit switches should be facing down. Line up the square pin on the motor with the square hole in the bracket. Secure with cotter pin. See figure 2.
4. Lift the pin end (right end) of the roller into position and slide the bracket onto the roller pin. Tighten two nuts to secure the bracket. Secure pin end with cotter pin. See figure 3.
5. Complete electrical hook-up by snapping motor wire connector into case connector.
6. Remove shipping brackets by removing the hex head screws from aluminum slat and case. Slat should move freely. See figure 2. (Only if the roller assembly is preinstalled.)
7. Test installation by operating the screen several times. Be prepared to stop the screen. Standard Duty Cycle: 1 MIN. ON/3 MIN. OFF. The fabric door (rear door) will not close until the wall switch is placed in the up position and when the screen motor stops at its limit switch in the up direction.

⚠ CAUTION: Excessive continuous operation may cause the motor to overheat. If this happens the motor will shut off until it cools to a normal operating temperature.

⚠ ATTENTION! Le fonctionnement continu et excessif peut provoquer une surchauffe. Si cela se produit, les moteurs s'arrêteront jusqu'à qu'ils se soient refroidis à la température normale de fonctionnement.

8. Remove any shipping foam attached to the inside of the access and fabric doors before operation.
9. Run the screen down enough to open the fabric door. Close the access door and reinstall the screws to secure the door.

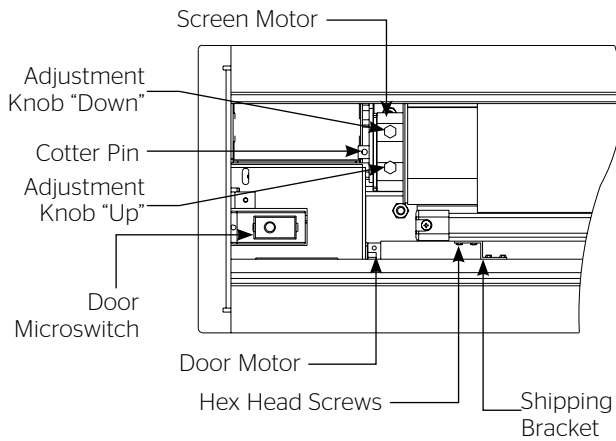

Figure 2

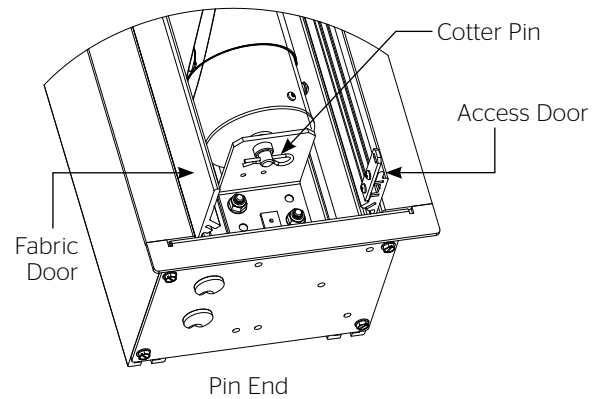

Figure 3

Screen Adjustment

NOTE: Use a screw driver or 5/32" Allen wrench to make adjustments.

More Screen Drop

1. Place operating switch in "down" position.
2. When the screen stops, turn the "down" limit knob (Fig. 2) one-quarter turn counterclockwise. Test by raising picture surface approximately two feet, then lower again. Repeat until desired picture surface position is attained.

⚠ CAUTION: Do not adjust for more drop than what was ordered. At least 1-1/2 wraps of fabric must remain on the roller. This screen comes standard with 12" black at the top.

⚠ ATTENTION! N'effectuez pas de réglage pour obtenir un déroulement supérieur à celui commandé. Au moins 1 à 1/2 tour de toile doit être maintenu sur le cylindre. Cet écran est doté de série d'une bande noire supérieure de 0 cm (0 po) ou 5 cm (2 po). Consultez la fiche technique pour plus de renseignements.

Less Screen Drop

1. Raise picture surface approximately two feet above desired level.
2. Place operating switch in "off" position.
3. Turn the "down" limit switch (Fig. 2) one-quarter turn clockwise. Test by raising picture surface approximately two feet, then lower again. Repeat until desired picture surface position is attained.

⚠ CAUTION: Adjusting the down limit switch for less drop by more than 6" can cause the screen surface to lose proper tensioning.

⚠ ATTENTION! LE FAIT D'AJOUTER NE DÉROULEZ PAS TROP L'ÉCRAN PLUS DE 15 CM (6PO) AUX INTERRUPTEURS DE FIN DE COURSE PEUT FAIRE PERDRE LA BONNE TENSION À LA SURFACE DE L'ÉCRAN.

⚠ CAUTION: Contact Da-Lite at 800-622-3737 or 574-267-8101 if door motor needs adjustment.

⚠ ATTENTION: Contactez Da-Lite au 800-622-3737 ou au 574-267-8101 au cas le moteur de porte doit être ajusté.

Tensioned Advantage (With Closure Door) Installation

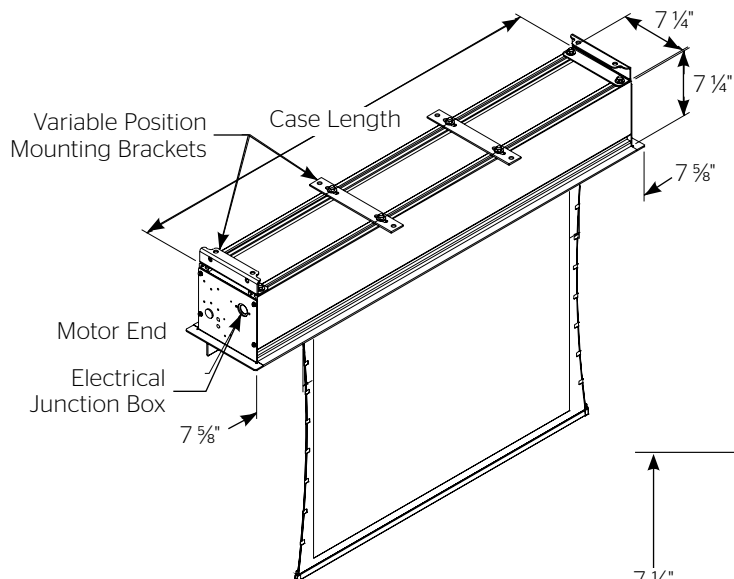

Flat Bracket Mounting Method

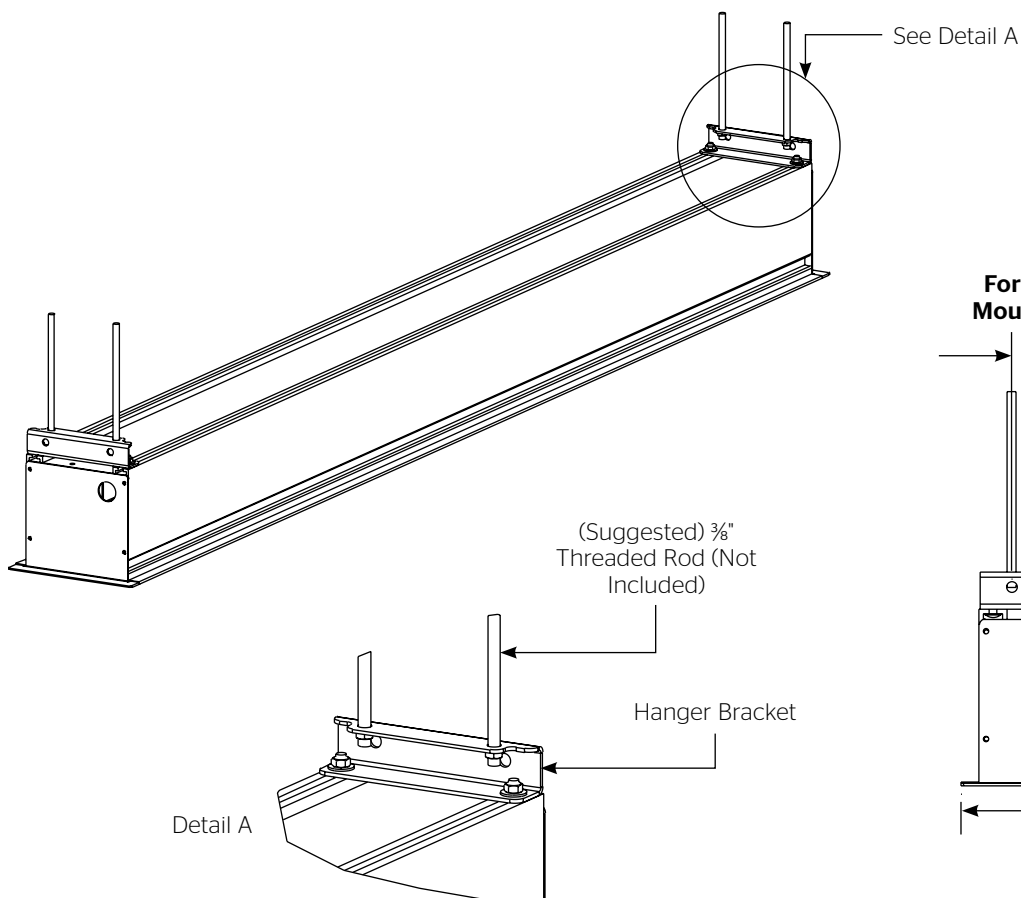
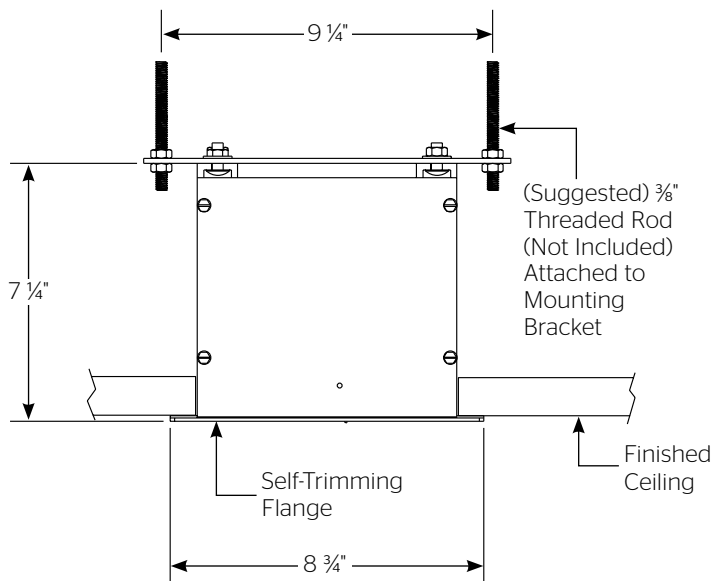

Formed Bracket Mounting Method

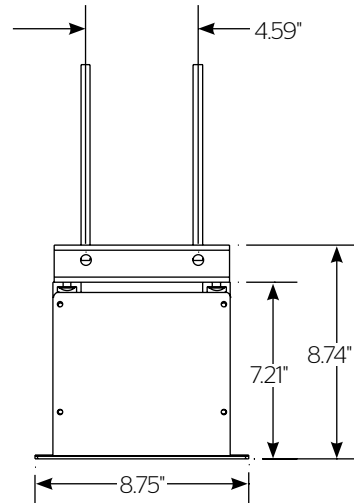

Tensioned Advantage (With Closure Door) Instructions For Standard Control

120V Wiring Diagram

NOTE: Electrical connections on left end of case.

Use provided knockouts for all electrical connections. DO NOT drill additional holes into screen case or end cap.

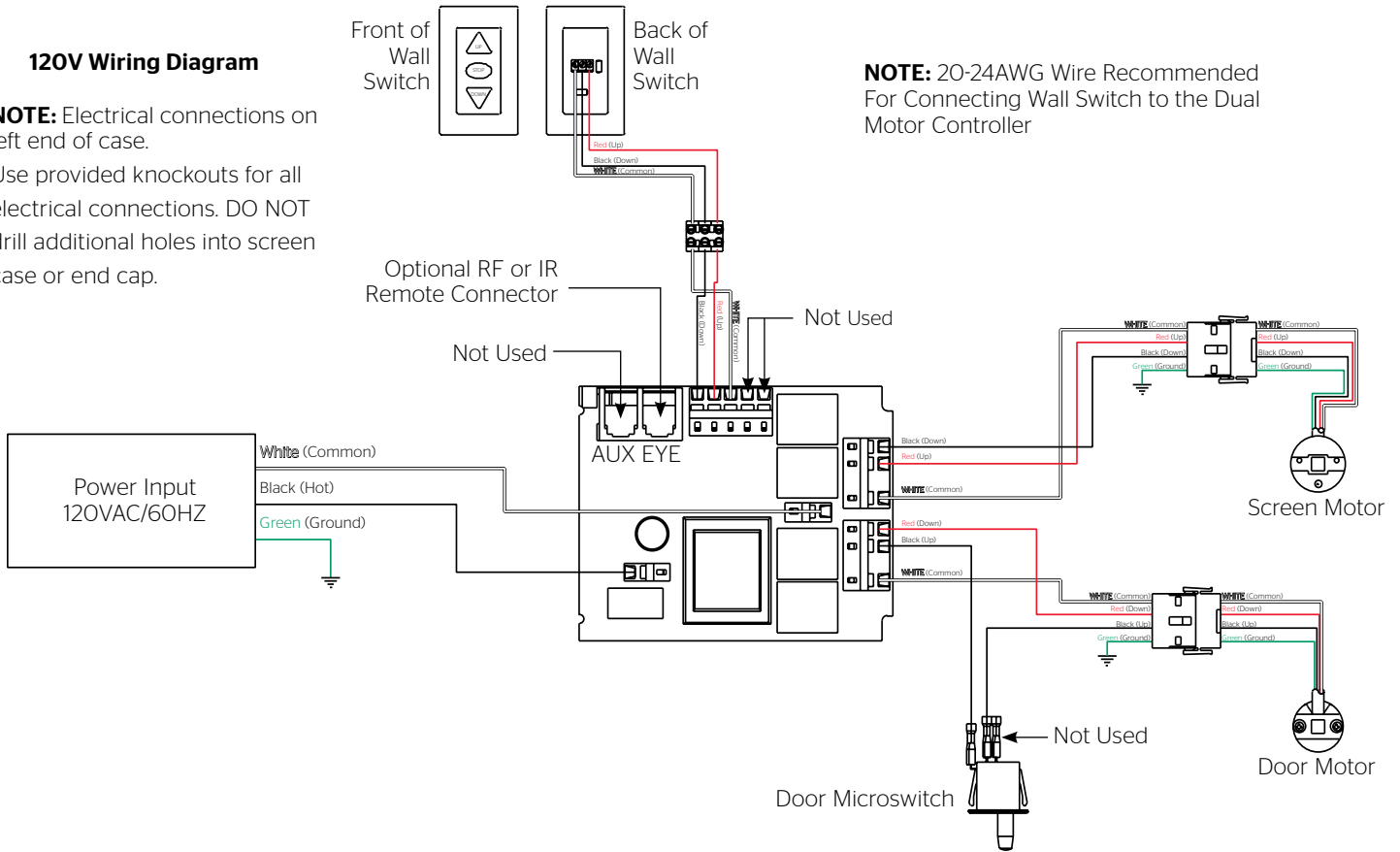

NOTE: 20-24AWG Wire Recommended For Connecting Wall Switch to the Dual Motor Controller

220/240V Wiring Diagram

NOTE: Electrical connections on left end of case.

Use provided knockouts for all electrical connections. DO NOT drill additional holes into screen case or end cap.

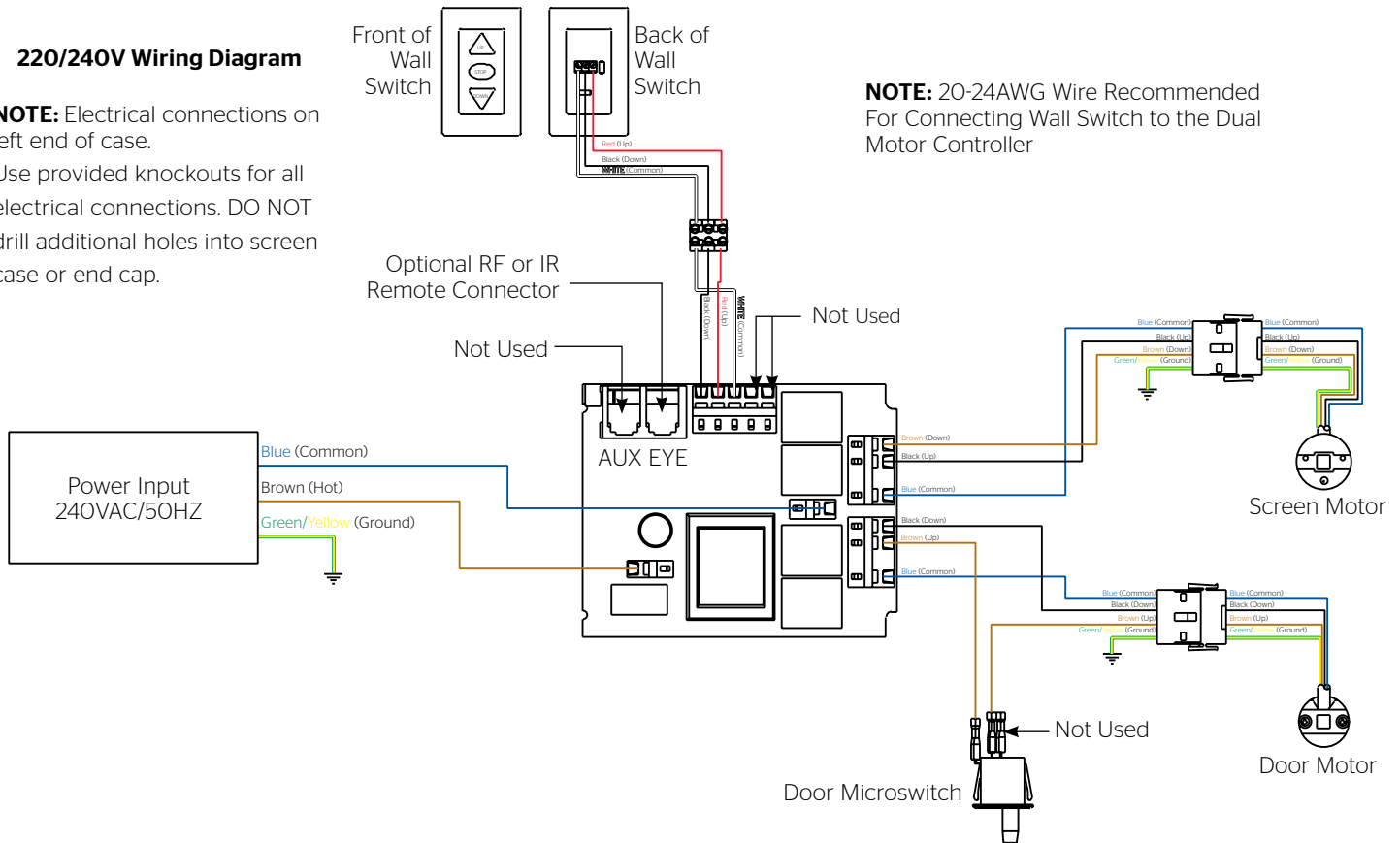

NOTE: 20-24AWG Wire Recommended For Connecting Wall Switch to the Dual Motor Controller

Tensioned Advantage (With Closure Door) Instructions Optional SCB-100 Control

120V Wiring Diagram

NOTE: Electrical connections on left end of case.

Use provided knockouts for all electrical connections. DO NOT drill additional holes into screen case or end cap.

NOTE: 20-24AWG Wire Recommended For Connecting Wall Switch to the Dual Motor Controller

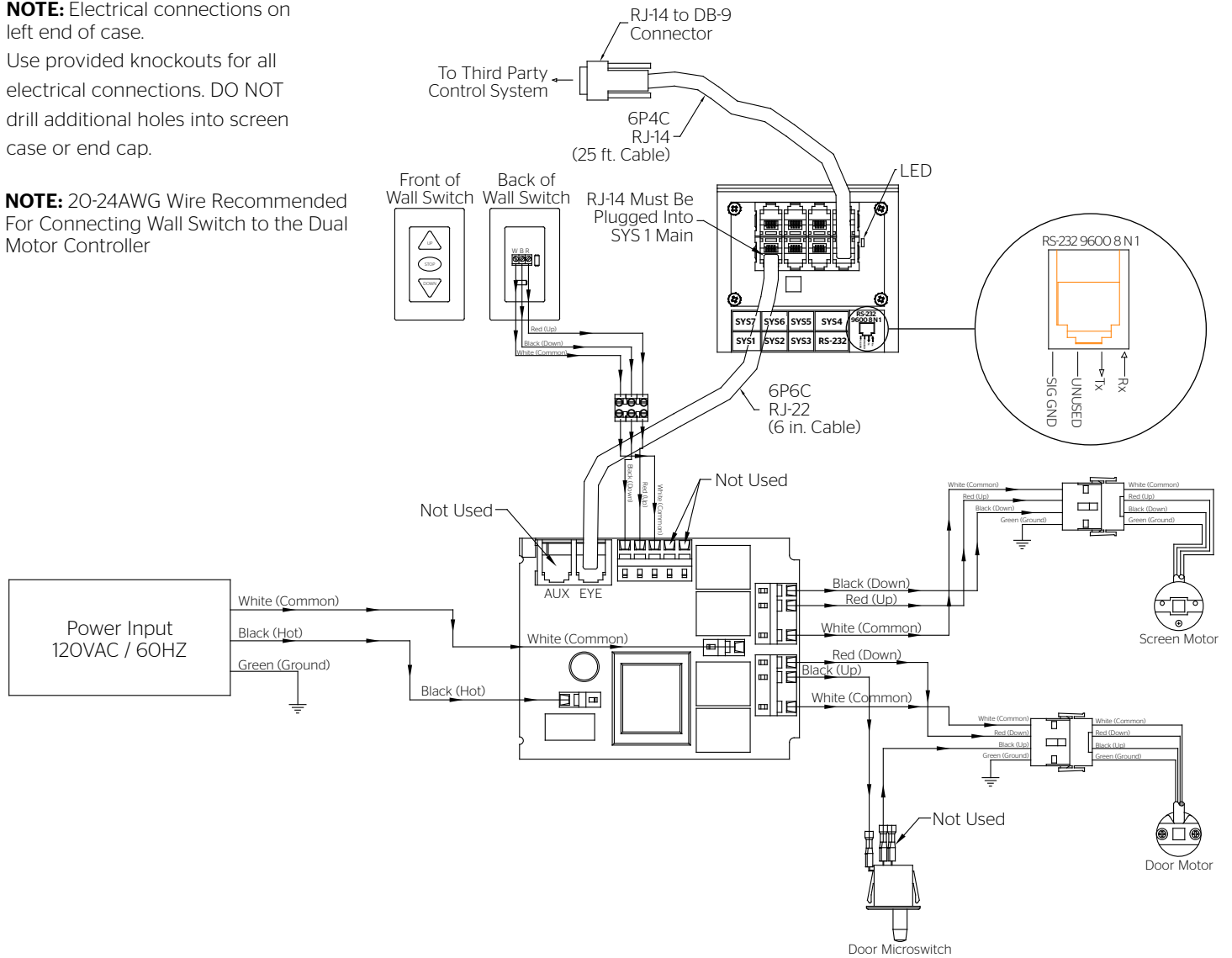

Communication Instructions

The connection settings for the SCB-100 are 9600 Baud Rate, 8 Data Bits, None Parity, 1 stop bit and XON/XOFF Flow Control. The control is NOT Bi-Directional, but it will give a response to commands sent.

1. When the SCB-100 unit first powers on it will send back the (Version, X-on). The LED on the SCB-100 unit will flash green, red, green and red.
2. To send the screen down the command is `*1c04;`
3. To send a stop command to the screen is `*1s04;`
4. To send the screen up the command is `*1o04;`
5. The unit will respond with a "LF" if command was good. It will respond with "U" if the command was not understood.

Tensioned Advantage (With Closure Door) Instructions Optional SCB-100 Control (continued)

220V Wiring Diagram

NOTE: Electrical connections on left end of case.

Use provided knockouts for all electrical connections. DO NOT drill additional holes into screen case or end cap.

NOTE: 20-24AWG Wire Recommended For Connecting Wall Switch to the Dual Motor Controller

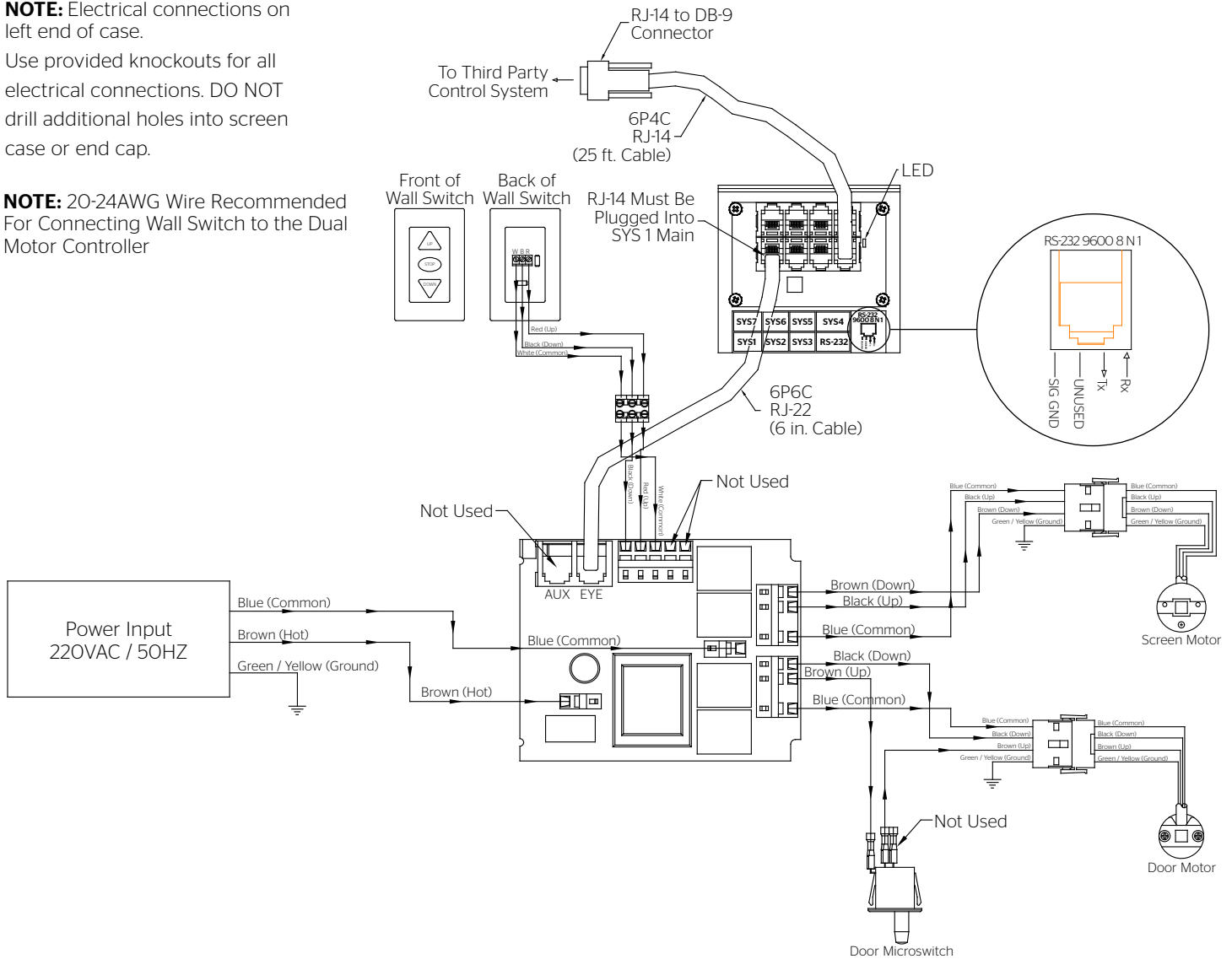

Communication Instructions

The connection settings for the SCB-100 are 9600 Baud Rate, 8 Data Bits, None Parity, 1 stop bit and XON/XOFF Flow Control. The control is NOT Bi-Directional, but it will give a response to commands sent.

1. When the SCB-100 unit first powers on it will send back the (Version, X-on). The LED on the SCB-100 unit will flash green, red, green and red.
2. To send the screen down the command is `"*1c04;"`
3. To send a stop command to the screen is `"*1s04;"`
4. To send the screen up the command is `"*1o04;"`
5. The unit will respond with a "LF" if command was good. It will respond with "U" if the command was not understood.

Troubleshooting

| Symptom | Cause | Solution |
|---|--|--|
| <p>If screen is not responding properly and SCB100 or SCB200 controls are used, contact the factory for troubleshooting assistance.</p> <p>Screen will not operate or will not go "down." Motor does not hum.</p> | Incorrect line voltage. | Verify 115-125V (or 220-240V). If insufficient voltage, rewire incoming electric line. |
| | Blown facility fuse. | Replace facility fuse. |
| | Tripped facility circuit breaker. | Reset facility circuit breaker. |
| | No power to operating switch or junction box. | Check above. Tighten all loose wire connections. Recheck wiring. See installation instructions. "Down" Position. Check for power across black and white leads. |
| | Power at junction box. Thermal overload tripped. | Let motor cool down for 15 minutes. Try again. |
| | Broken wire in the "down" position. | Check for continuity. |
| | Defective motor, limit switch or capacitor. | Replace motor assembly. NOTE: Motor is a sealed assembly. |
| Motor hums. | Capacitor burned out. | Replace motor assembly. |
| <p>Screen will not move upward. Motor does not hum.</p> | Incorrect line voltage. | Verify 115-125V (or 220-240V). If insufficient voltage, rewire incoming electric line. |
| | Blown facility fuse. | Replace facility fuse. |
| | Tripped facility circuit breaker. | Reset facility circuit breaker. |
| | No power to operating switch or junction box. | Check above. Tighten all loose wire connections. See above. "Up" Position. Check for power across red and white leads. |
| | Open door limit switch. | Replace switch. |
| | Power at junction box. Thermal overload tripped. | Let motor cool down for 15 minutes. Try again. |
| | Broken wire in the "up" position. | Check for continuity. |
| | Defective motor, limit switch or capacitor. | Replace motor assembly. NOTE: Motor is a sealed assembly. |
| Motor hums. | Capacitor burned out. | Replace motor assembly. |

Troubleshooting (continued)

| Symptom | Cause | Solution |
|---|---|--|
| Door will not open. | Hinge is bound or has a foreign substance on it which does not allow it to open by gravity. | Check installation to free door. Clear any foreign substance; i.e., paint or plaster from hinge. |
| | No power. | See above. |
| Door does not close. | Open door limit switch. | Replace switch. |
| | No power from screen motor. | Replace screen motor. |
| “Down” limit switch incorrect.. | “Down” limit switch out of adjustment. | See installation instructions. |
| Noise. NOTE: Screen will operate with a low-pitched hum. | Buzzing noise. | Adjust door limit switch (too far down). |
| | Gear noise. | Replace motor assembly. |
| Coasting. | Defective brake. | Replace motor assembly. |
| Roller displaced from mounting bracket. | Pin end slipped out of nylon bearing. | Realign pin end bracket. |
| Fabric hangs crooked. | Screen not installed properly. | Check for level and plumb. |
| | Fabric is damaged. | Replace fabric. |
| Door closes before screen is all the way up. | Screen “up” limit out of adjustment. | Adjust “up” limit (call factory for instructions). |
| Door opens but screen does not operate. | Loose wire. | Check all wiring and connections. |

Conditions for Transportation and Storage

- Temperature: Between 40 - 100°F (5 - 40°C)
- Relative Humidity: 30% to 70%, non-condensing
- Always keep the projection screen horizontal during transport and storage
- Make sure the entire package is supported when stored
- Do not stack more than six projection screens on top of each other
- Make sure the heaviest package is placed at the bottom of the stack

Screen surface should be allowed to air out once every two months, or otherwise used on a regular basis, if the temperature is above 72°F (22°C) and at least once every month if the temperature goes above 85°F (30°C).

LIMITED FIVE-YEAR WARRANTY ON DA-LITE PRESENTATION PRODUCTS

Legrand AV Inc. warrants certain Da-Lite branded products to the original purchaser only, to be free from defects in materials and workmanship for a period of five (5) years from the date of purchase by the original purchaser; provided they are properly operated according to Da-Lite's instructions and are not damaged due to improper handling or treatment after shipment from the factory.

Limited five-year warranty applies to the following products:

Wireline Advantage®, Tensioned Advantage Series, Advantage Series, Tensioned DescenderPro, DescenderPro, Tensioned Conference, Tensioned Professional, Professional, Da-Lift Projector Lifts, Tensioned Contour®, Contour, Tensioned Cosmopolitan® Series, Cosmopolitan Series, Designer Contour, Slimline, Studio, Arena, Motorized Scenic Roller, Ascender, Parallax®, Parallax Thin, FullVision, UTB Contour, Cinema Contour, Da-Snap, Perm-Wall, Imager, IDEA™ Screen, IDEA Panoramic, Fast-Fold® Deluxe, Fast-Fold Deluxe Drapery Kits, Flex Plex, Da-Glas, Da-Plex Rear Projection Mirror System, and Holo Screen.

This warranty does not apply to equipment showing evidence of misuse, abuse or accidental damage, or which has been tampered with or repaired by a person other than authorized Da-Lite personnel.

Da-Lite's sole obligation under this warranty shall be to repair or to replace (at Da-Lite's option) the defective part of the merchandise. Returns for service should be made to your Da-Lite dealer. If it is necessary for the dealer to return the screen or part to Da-Lite, transportation expenses to and from Da-Lite are payable by the purchaser and Da-Lite is not responsible for damage in shipment. To protect yourself against damage or loss in transit, insure the product and prepay all transportation expenses.

TO THE MAXIMUM EXTENT PERMITTED BY APPLICABLE LAW, THIS WARRANTY IS IN LIEU OF ALL OTHER WARRANTIES, EXPRESS OR IMPLIED, INCLUDING WARRANTIES AS TO FITNESS FOR USE AND MERCHANTABILITY. Any implied warranties of fitness for use, or merchantability, that may be mandated by statute or rule of law are limited to the five (5) year warranty period. This warranty gives you specific legal rights, and you may also have other rights, which vary from state-to-state. **TO THE MAXIMUM EXTENT PERMITTED BY APPLICABLE LAW, NO LIABILITY IS ASSUMED FOR EXPENSES OR DAMAGES RESULTING FROM INTERRUPTION IN OPERATION OF EQUIPMENT, OR FOR INCIDENTAL, DIRECT, OR CONSEQUENTIAL DAMAGES OF ANY NATURE.**

In the event that there is a defect in materials or workmanship of a Da-Lite product, you may contact Customer Care at 3100 North Detroit Street, Warsaw, IN 46582, (866) 977-3901.

IMPORTANT: THIS WARRANTY SHALL NOT BE VALID AND DA-LITE BRANDED PRODUCTS SHALL NOT BE BOUND BY THIS WARRANTY IF THE PRODUCT IS NOT OPERATED IN ACCORDANCE WITH THE DA-LITE WRITTEN INSTRUCTIONS.

Keep your sales receipt to prove the date of purchase and your original ownership.



FOR YOUR IMAGE | legrandav.com

| | | |
|--------|-------------------|--|
| USA | P 866.977.3901 | E av.da-lite.support@legrand.com |
| CANADA | P 877.345.4329 | E av.da-lite.support@legrand.com |
| EMEA | P +31 495 580 840 | E av.emea.sales@legrand.com |
| APAC | P +852 2145 4099 | E av.asia.sales@legrand.com |

© 2020 Legrand AV Inc. 200072 (Rev. 3) 3/20 Da-Lite is a registered trademark of Legrand AV Inc. All other brand names or marks are used for identification purposes and are trademarks of their respective owners. All patents are protected under existing designations. Other patents pending.



COMMERCIAL BRANDS

Chief | Da-Lite | Middle Atlantic | Projecta | Vaddio

88585



INSTRUCTION MANUAL
Tensioned Advantage®



Original Instructions

Disclaimer

Legrand AV Inc. and its affiliated companies and subsidiaries (collectively, "Legrand AV"), intend to make this manual accurate and complete. However, Legrand AV makes no claim that the information contained herein covers all details, conditions or variations, nor does it provide for every possible contingency in connection with the installation or use of the products described herein. The content herein is subject to change without notice or obligation of any kind. To the maximum extent permitted by applicable law, Legrand AV makes no representation or warranty, expressed or implied, regarding the information contained herein. Furthermore, Legrand AV assumes no responsibility for accuracy, completeness or sufficiency of the information contained in this document.

Da-Lite® is a registered trademark of Legrand AV. All rights reserved.

Important Safety Instructions

When using your video equipment, basic safety precautions should always be followed, including the following:

1. Read and understand all instructions before using.
2. Maximum surrounding air temperature 122°F (50°C).
3. Main disconnect must be incorporated in the fixed wiring in accordance with the wiring rules.
4. Rated for indoor use only.
5. Use copper rated conductors rated 167°F (75°C) or higher.
6. If the supply cord is damaged, it must be replaced by the manufacturer, its service agent or similarly qualified persons in order to avoid hazard.
7. Supplied drive is only intended for use in Da-Lite screen models Advantage, Contour, and Cosmopolitan.
8. Position the cord so that it will not be tripped over, pulled, or contact hot surfaces.
9. If an extension cord is necessary, a cord with a current rating at least equal to that of the appliance should be used. Cords rated for less amperage than the appliance may overheat.
10. To reduce the risk of electric shock, do not disassemble this appliance. Contact an authorized service dealer when repair work is required. Incorrect reassembly can cause electric shock when the appliance is used subsequently.
11. The use of an accessory attachment not recommended by the manufacturer may cause a risk of fire, electric shock, or injury to persons.
12. Failure to provide adequate structural strength for this component can result in serious personal injury or damage to equipment! It is the installer's responsibility to make sure the structure to which this component is attached can support the weight of all equipment. Reinforce the structure as required before installing the component.
13. Use this projection screen only for its intended use as described in these instructions. Do not use attachments not recommended by the manufacturer.

Save These Instructions

Tensioned Advantage Suggested Methods of Installation

Method 1

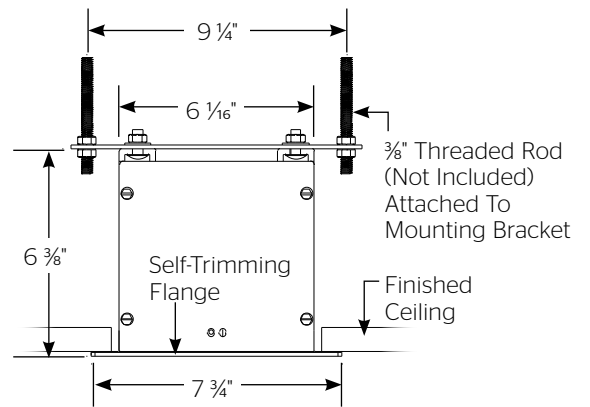
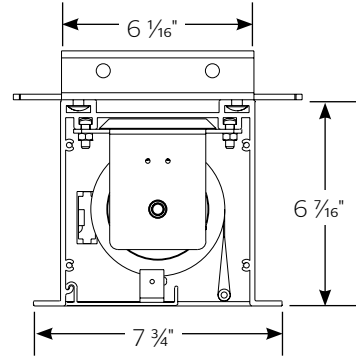
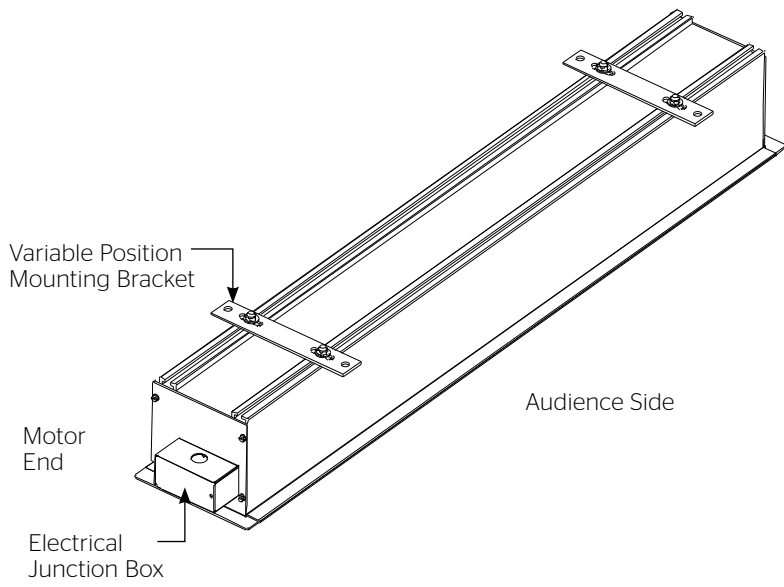

Method 2

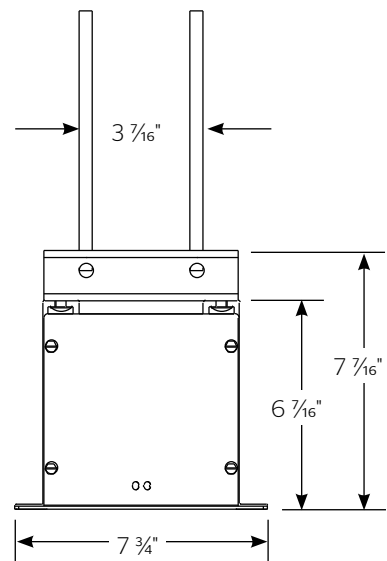
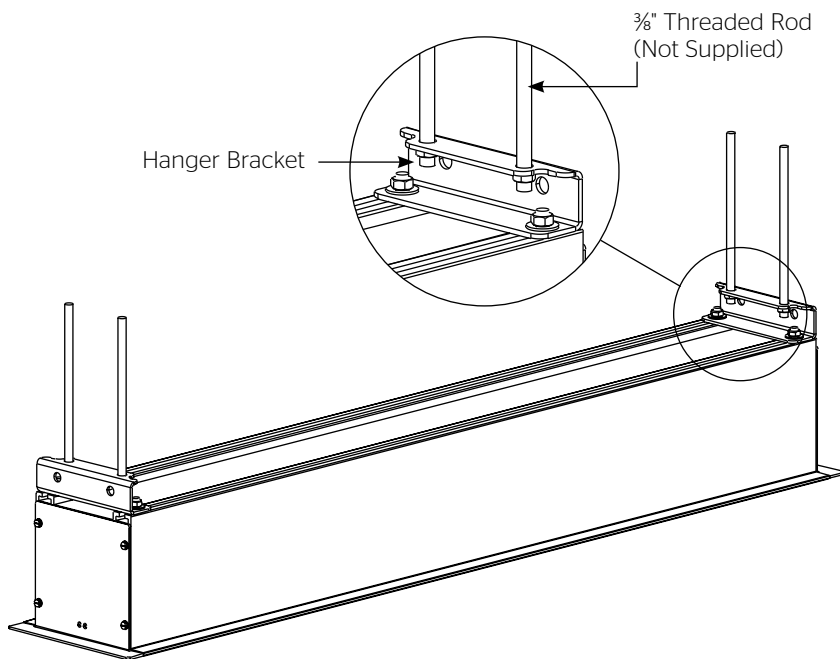

Tools Required for Installation

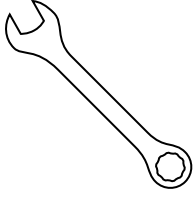

1/2" and 5/16" Open Wrench
or Socket Driver

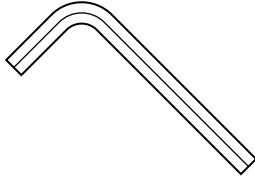

1/8" Hex Key
(included)

Pre-Installation

1. Carefully unpack case from shipping carton.
2. Set aside the Installation Kit. Items inside will be used during installation.
3. Make sure to recheck measurement of case for proper installation clearance.
4. Remove any protective foam covering the outside of the case.
5. For shipping purposes, foam is also inserted between the roller brackets and end caps (Figure 1). Remove these foam blocks from the ends.
6. Remove the hanger brackets from the top of the case using a 1/2" wrench. Do not discard the hardware; it will be used during case installation to re-attach the hanger brackets for mounting.

Case Installation

1. Hang case and attach to support structure with bolts. See Suggested Methods of Installation.
2. Tighten bolts until trim flange is flush with ceiling.
NOTE: For proper operation, case must be levelled side to side and front to back.
3. Remove 2 screws to open junction box. Install electrical connections that apply to your unit. Make sure to review the wiring diagram for proper hook up. Replace junction box cover and secure with 2 screws.

NOTE: Must be installed in accordance with the requirements of the Local Building Codes, the Canadian Electrical Code (CEC), CAN/CSA C22.1 and the National Electric Code (NEC), NFPA 70.

If your case was ordered in advance of the screen and roller assembly, your installation is now complete. Continue to step 4 if your Tensioned Advantage was ordered as a complete unit.

4. Use a 5/16" socket or wrench and the supplied 1/8" hex key to remove silver shipping brackets attached to slat and screen case.
5. Test installation by running screen up and down a few times. Be prepared to stop screen should any objects obstruct the movement of the screen. To prevent damage to the motor, the standard duty cycle is 1 minute on and 3 minutes off.

Screen And Roller Assembly Installation

Tools required for screen and roller assembly:

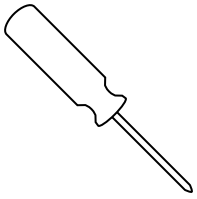

#2 Phillips Screwdriver

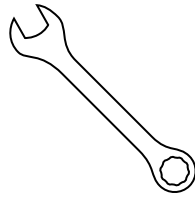

1/2", 1/4" and 5/16"
Open Wrench
or Socket Driver

Follow these steps if your screen and roller assembly was ordered separately from the case.

1. Remove the access door. First, remove the 2 screws from the ends using a #2 Phillips screwdriver. Be sure to support the door during this step to avoid injury. Then lift the door slightly and pull away from the edge of the case (Figure 1).
2. Carefully unpack screen and roller assembly. Use a 5/16" socket or wrench and a #2 Phillips Screwdriver to remove shipping brackets attached to slat. Remove fabric and roller assembly from shipping board using a 1/2" wrench. Leave packing paper on roller.
3. To install screen and roller assembly, loosen (but do not remove) four 1/4-20 nuts securing pin end bracket (opposite end from the junction box) to the case housing. Slide the pin end bracket towards the end of the case (Figure 2).
4. Insert the motor end square shaft into the motor end bracket (junction box end) and secure with the cotter pin (Figure 2).
5. Moving to the pin end of the case, slide the pin end bracket until the hole fits securely over the pin and secure with the cotter pin. Tighten the 1/4-20 nuts on the pin end bracket securely (Figure 2).
6. Complete electrical hook-up by snapping motor wire connector into case connector (Figure 2).
8. Test installation by running screen up and down a few times. Be prepared to stop screen should any objects obstruct the movement of the screen. To prevent damage to the motor, the standard duty cycle is 1 minute on and 3 minutes off.
9. Re-install the access door. Procedure is the reverse of step 1 listed above.

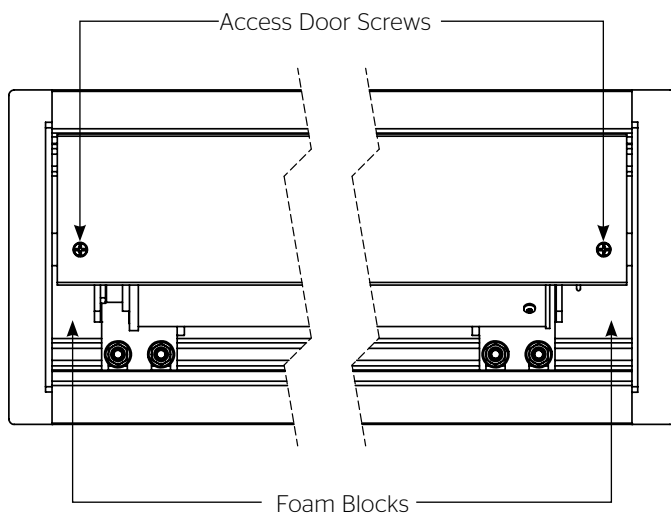

Figure 1

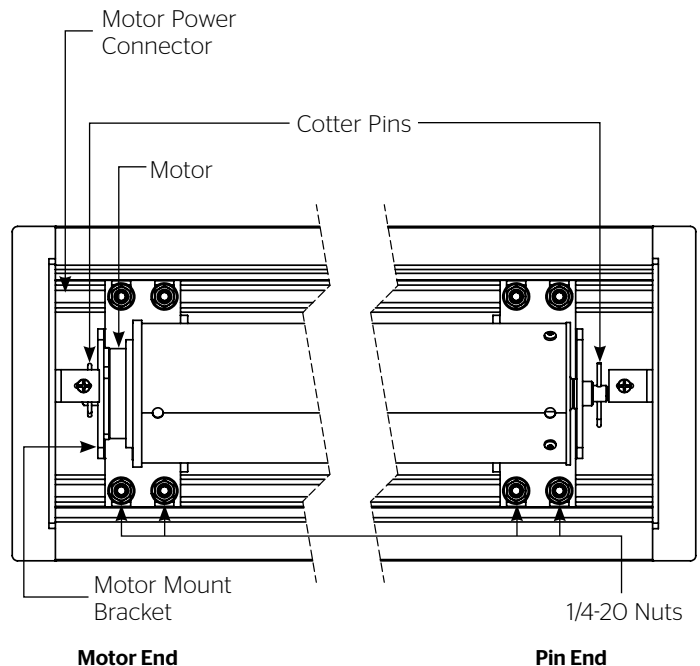

Figure 2

Screen And Roller Assembly Installation (continued)

Replacement Motor Instruction

Rated torque of model DL45E-10/26 is 10 N/m with a duty cycle of 1 min. on / 3 min. off.

Rated torque of model DL45EQ-6/28 is 6 N/m with a duty cycle of 1 min. on / 3 min. off.

Motor is intended for use in Da-Lite screens incorporating a 3.00" and 3.25" roller diameter.

1. Make sure motor collar is on motor.
2. Collars keyway must line up with the key on the motor.
3. Secure motor drive wheel on output shaft of motor and insert retaining clip.

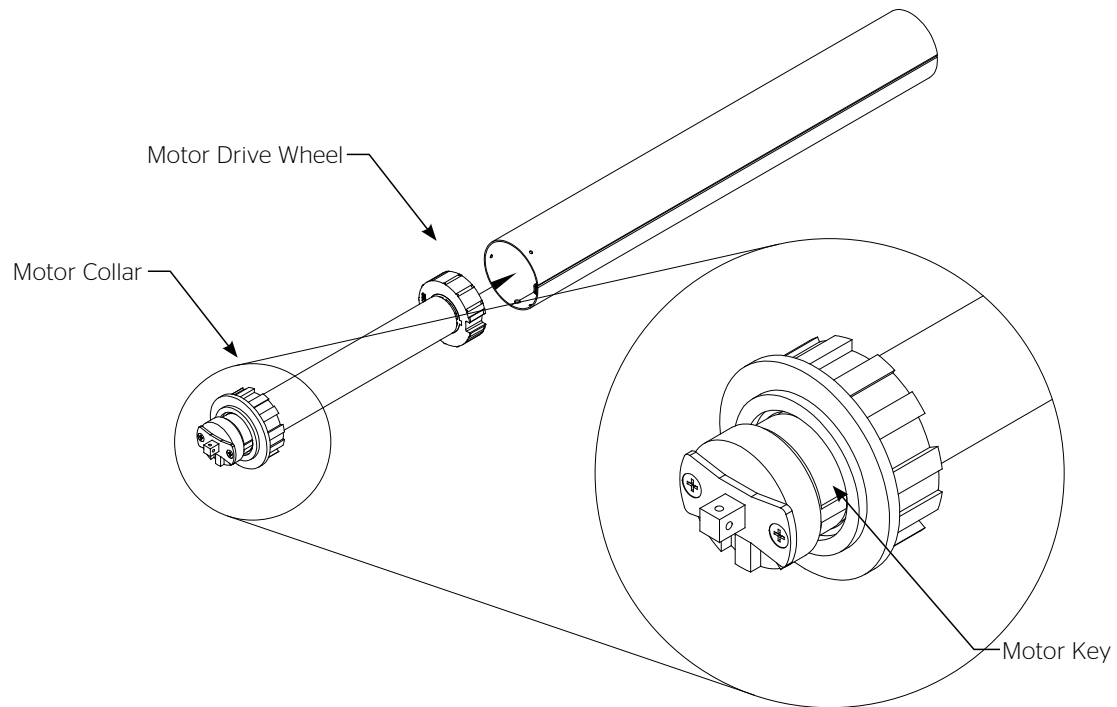

4. Insert motor in tube with seam of tube lined up with drive wheel and collar cutouts.

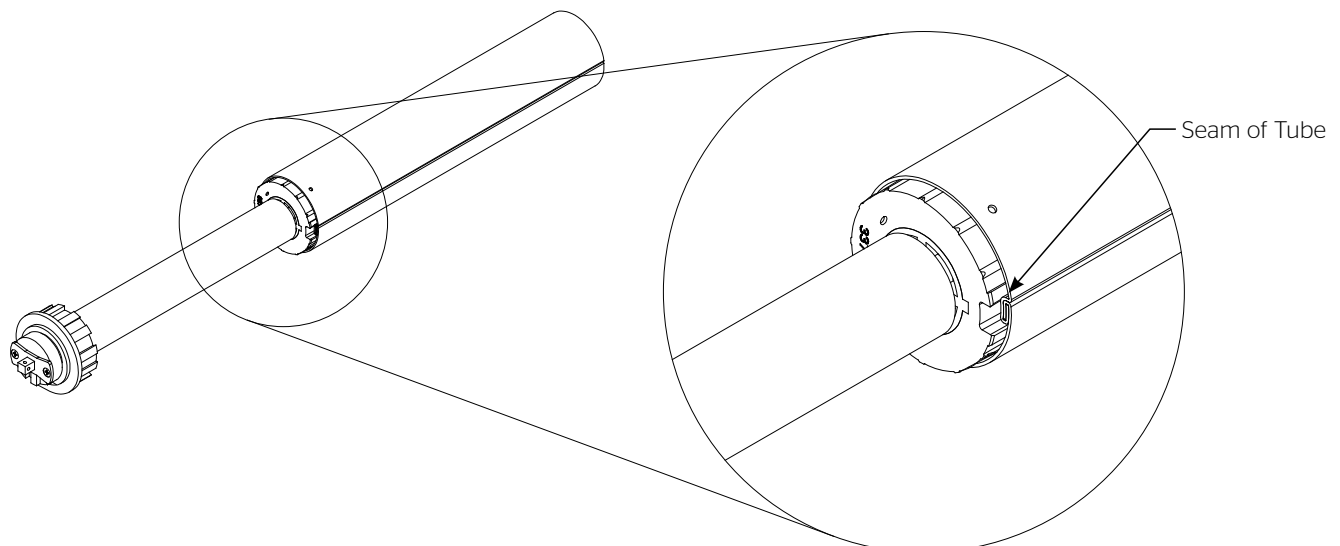

Tensioned Advantage Installation for 120V Screens

120V Wiring Diagram

3-conductor 20-24 gauge wire can be used in place of the supplied RJ-14 cable to connect the wall switch. Connect the BUS terminals on the wall switch to the corresponding BUS terminals on the splitter board.

IMPORTANT NOTE: The wall switch is REQUIRED to make any limit switch adjustments, EVEN if a third party control system is used. Therefore, it is advised to wire the switch or provide a 3-conductor connection that is accessible.

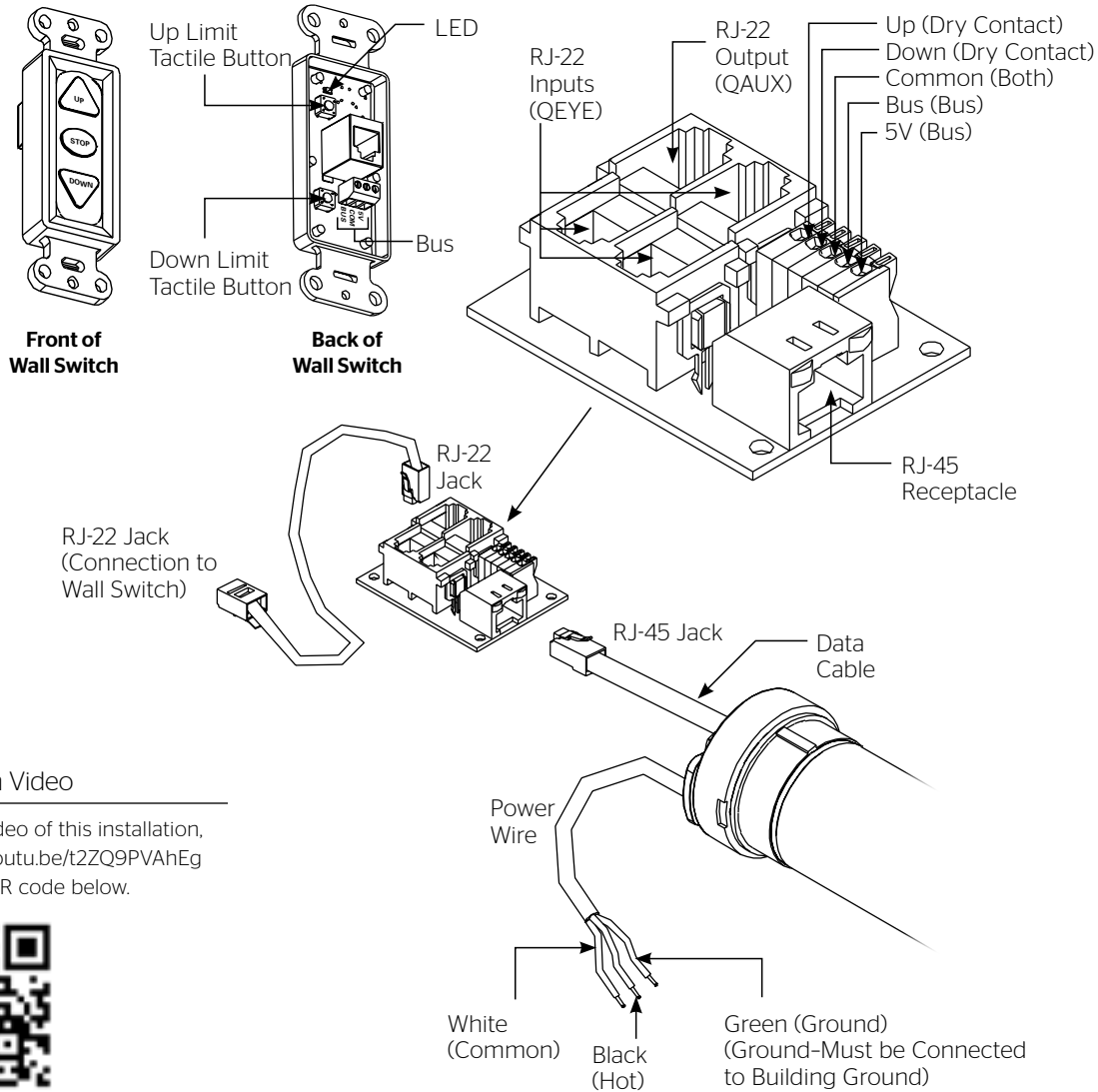

Installation Video

To view a video of this installation, visit <http://youtu.be/t2ZQ9PVAhEg> or use the QR code below.



Power Input 120VAC / 60Hz

RJ-14 Pin-Outs (Tab Is Facing Down)



Supplied RJ-14 cable

RJ-22 Pin-Outs (Tab Is Facing Down)

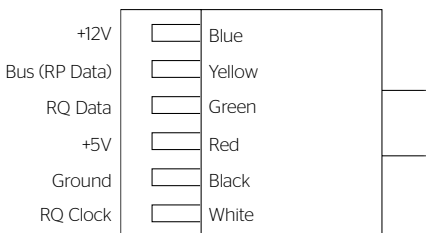

Standard RJ-22 can be used in place of RJ-14 cable

RJ-45 Pin-Outs (Tab Is Facing Down)

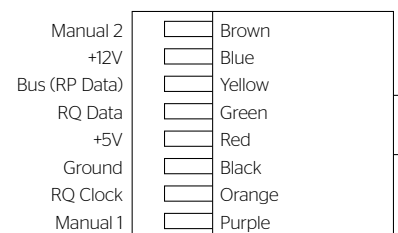

Tensioned Advantage Installation for 220V Screens

220V Wiring Diagram with Operation & Limit Adjustment Wall Switch

3-conductor 20-24 gauge wire can be used in place of the supplied RJ-14 cable to connect the wall switch. Connect the BUS terminals on the wall switch to the corresponding BUS terminals on the splitter board.

IMPORTANT NOTE: The wall switch is REQUIRED to make any limit switch adjustments, EVEN if a third party control system is used. Therefore, it is advised to wire the switch or provide a 3-conductor connection that is accessible.

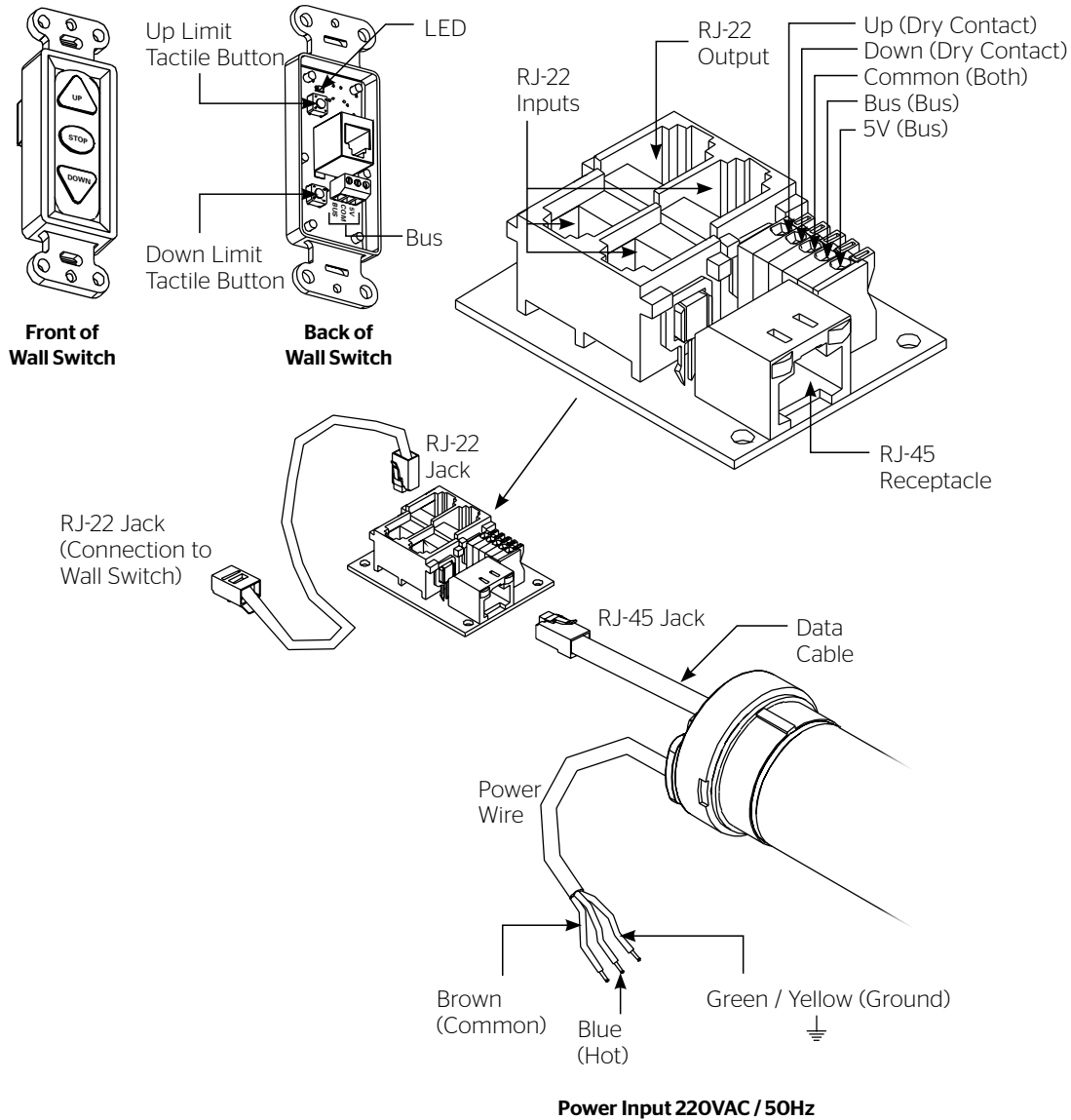

RJ-14 Pin-Outs (Tab Is Facing Down)

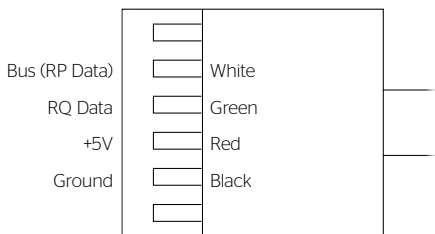

Supplied RJ-14 cable

RJ-22 Pin-Outs (Tab Is Facing Down)

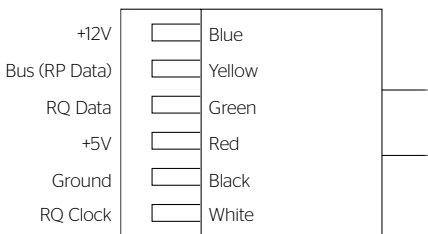

Standard RJ-22 can be used in place of RJ-14 cable

RJ-45 Pin-Outs (Tab Is Facing Down)

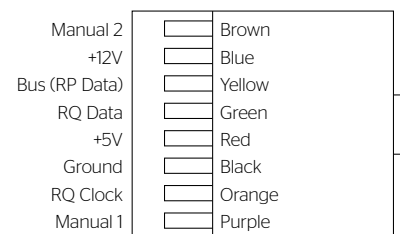

Tensioned Advantage Installation for 220V Screens (continued)

220V Wiring Diagram with European Style Wall Switch

Use 3-conductor 20-24 gauge wire for wall switch connections.

IMPORTANT NOTE: The European style wall switch is for operation only and CANNOT be used to make limit switch adjustments. Therefore, it is advised to wire the limit adjustment switch or provide a 3-conductor connection that is accessible.

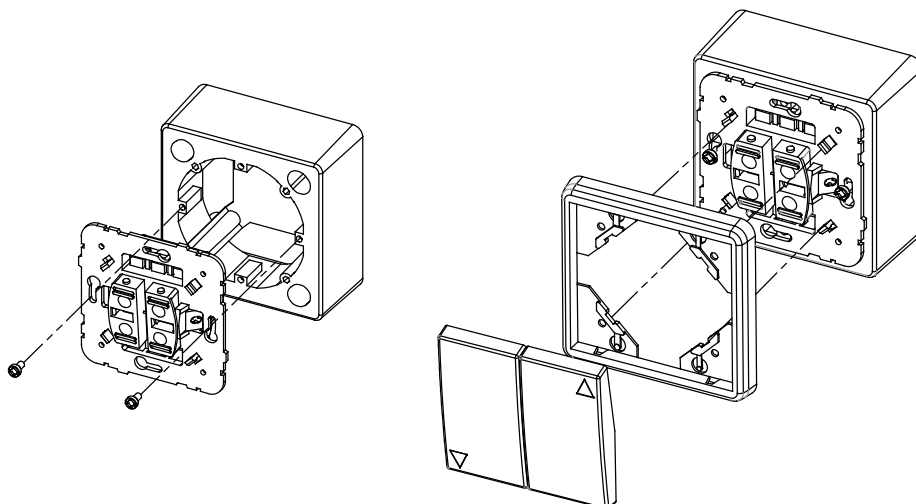
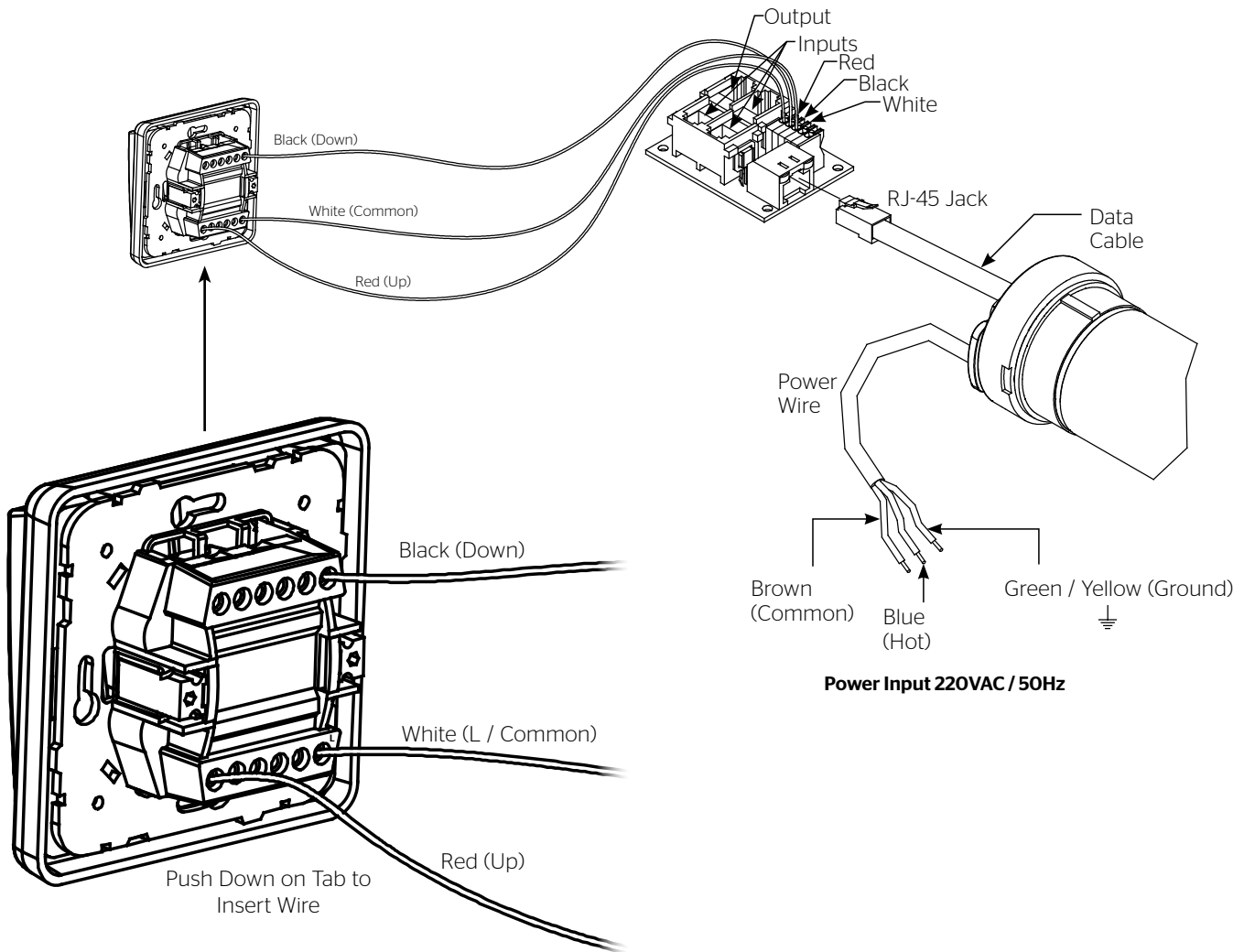

Optional Built-In Video Projector Interface

⚠ CAUTION: The projector must be turned off before connecting the trigger wires to the projector. Failure to do so may damage the controller.

⚠ ATTENTION: Le projecteur doit être éteint avant de brancher les fils de déclenchement à celui-ci. Tout manquement à cette instruction pourrait endommager le contrôleur.

Use 2-conductor 18-24 gauge wire to extend the low voltage connection from the projector's 5 or 12-volt screen trigger output to the length required to reach the VPI.

NOTE: When extending the low voltage connection from the projector's screen trigger output polarity does not matter. **The red and black wires from the VPI are interchangeable.**

IMPORTANT NOTE: The wall switch is REQUIRED to make any limit switch adjustments, EVEN if a third party control system is used. Therefore, it is advised to wire the switch or provide a 3-conductor connection that is accessible.

3-conductor 20-24 gauge wire can be used in place of the supplied RJ-14 cable to connect the wall switch. Connect the BUS terminals on the wall switch to the corresponding BUS terminals on the splitter board.

See 120V or 220V wiring diagram for complete wiring instructions.

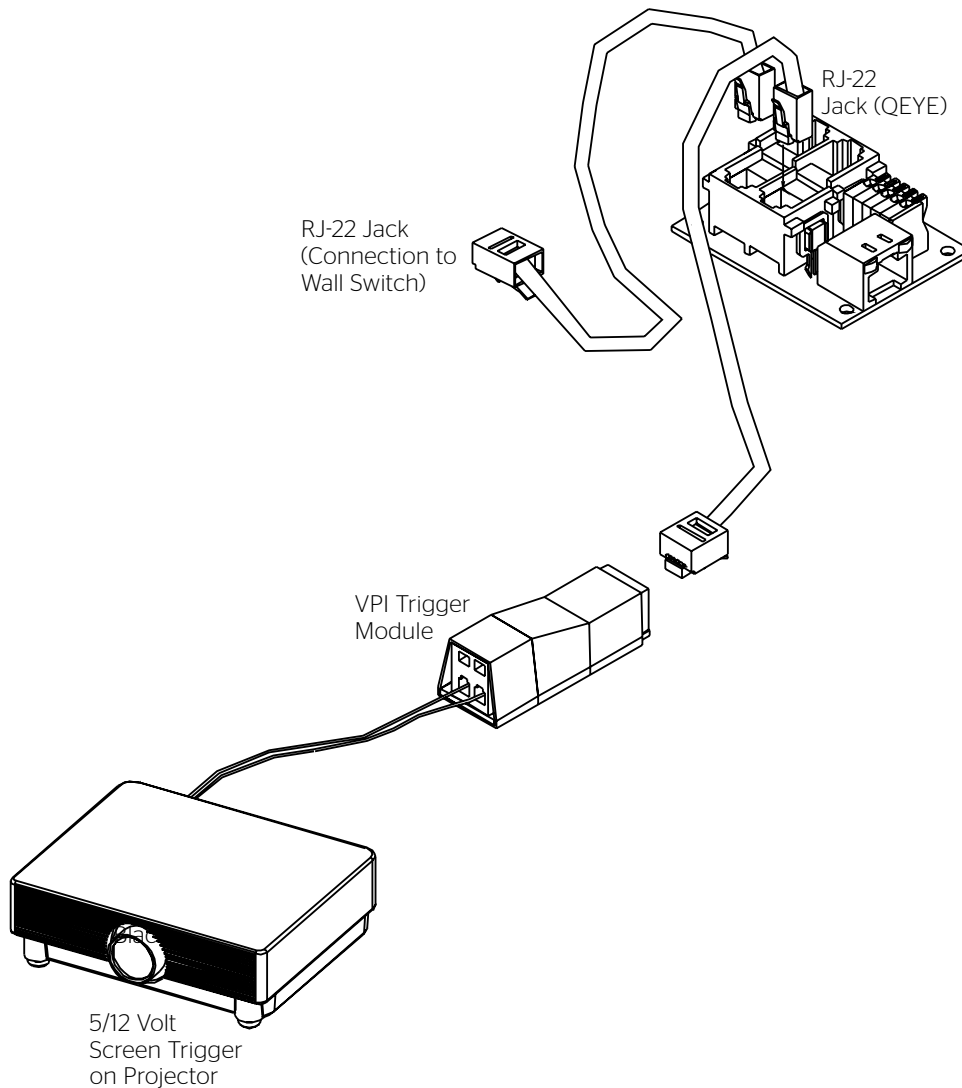

Optional Built-In SCB-100

BUILT-IN SCB-100 CONTROL

Locate the 11-pin connector in the junction box of the screen.

RS-232 PORTS

The SCB-100 has two RS-232 ports. Both ports have three wire connections.

- RX-Data being received into the SCB-100
- TX-Data going out of the SCB-100
- G-Ground

WALL SWITCH

The wall switch terminal is a dry contact closure. Do not apply voltage to this terminal or the control will be damaged.

1. Install the wall switch where desired.
2. Use 3-conductor 20-24 gauge wire to extend the switch wire to the required length.

12VDC OUT

The SCB-100 supplies power to the optional NET-100 network adaptor. If you are using the NET-100 adaptor, connect the power wire from the NET-100 to the 12VDC output terminal.

RS-232 COMMUNICATIONS

The command protocols are as follows.

- Screen 1 up: @1U
- Screen 1 stop: @1S
- Screen 1 down: @1D
- Screen 2 up: @2U
- Screen 2 stop: @2S
- Screen 2 down: @2D
- Poll: @P

Response to a poll is @1x2x where x is U for up, S for stop, D for down.

Communications is 9600 baud, 8 data bits, No parity, 1 stop bit.

No "Return" or "Enter" is required at end of string. The command will be executed as soon as the U, D, or S is received.

There is a 50ms time out if a valid character is received but the string is not finished. All command characters must be sent in one packet.

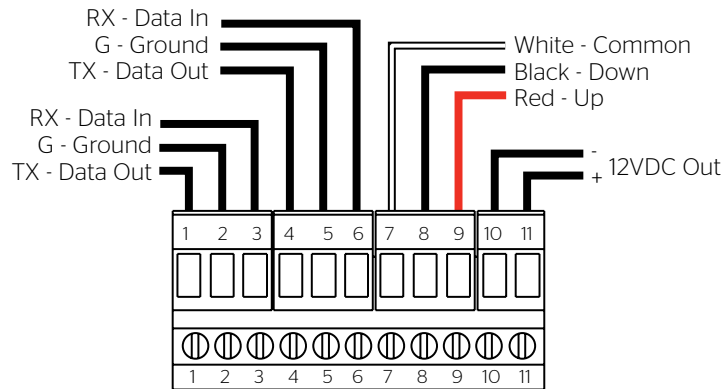

Terminals 1-3 = RS232 Port 2
Terminals 4-6 = RS232 Port 1
Terminals 7-9 = Wall Switch
Terminals 10-11 = Net-100 Controller

For optional SCB-200, see separate instruction manual.

Screen Adjustment

For Screens with Standard Built-In Low Voltage Control or Optional VPI

If your Tensioned Advantage was ordered as a complete unit, the up and down limits were pre-set by Da-Lite. If your screen and roller assembly was ordered separately from the case, or if general adjustment is needed, please follow the steps below and refer to the Wiring Diagram.

1. Locate the wall switch and remove the cover plate from the wall switch and remove the switch from the junction box.
2. Locate the two tactile buttons on the back of the switch. They are black round buttons on silver plates.
3. To adjust the down limit switch, press and hold the down tactile button until the LED on the back of the switch turns solid red. This will put the motor in limit set mode. Turn the wall switch over and use the down button on the front of the switch. Press and hold the down button until the desired down position is reached. If you travel too far down, press the up button to move the screen upward. If you press and let go of either the up or down buttons, the motor will do a small jog in that direction for fine adjustment of the screen. Once the desired position is reached, turn the switch over; press and hold the down tactile button until the LED on back of switch blinks red twice. The down limit is now set.

⚠ CAUTION: Do not adjust for more drop than what was ordered. At least 1-1/2 wraps of fabric must remain on the roller.

⚠ ATTENTION! N'effectuez pas de réglage pour obtenir un déroulement supérieur à celui commandé. Au moins 1 à 1/2 tour de toile doit être maintenu sur le cylindre.

NOTE: If the screen is in limit set mode and no buttons are pushed for 20 seconds, the LED on the back of the wall switch will turn off, the motor will return to run mode and no changes will be saved. If this occurs, return to step 3 for down limit adjustment or step 4 for up limit adjustment.

NOTE: All screens except Parallax standard with 12" black drop at the top. Screens with Parallax surface standard with 2" of black drop at the top.

4. To adjust the up limit switch, press and hold the up tactile button until the LED on the back of the switch turns solid green. This will put the motor in limit set mode. Turn the wall switch over and use the up button on the front of the switch. Press and hold the up button until the desired up position is reached. If you travel too far up, press the down button to move the screen downward. If you press and let go of either the up or down buttons, the motor will do a small jog in that direction for fine adjustment of the screen. Once the desired position is reached, turn the switch over; press and hold the up tactile button until the LED on back of switch blinks green twice. The up limit is now set.

⚠ CAUTION: Adjusting the down limit switch for less drop by more than 6" can cause the screen surface to lose proper tensioning.

⚠ ATTENTION! LE FAIT D'AJOUTER NE DÉROULEZ PAS TROP L'ÉCRAN PLUS DE 15 CM (6PO) AUX INTERRUPTEURS DE FIN DE COURSE PEUT FAIRE PERDRE LA BONNE TENSION À LA SURFACE DE L'ÉCRAN.

5. To test the limit switch settings, press and release the up or down buttons on the switch to operate the screen.
6. Replace the switch and cover plate on the wall.

IMPORTANT NOTE: The wall switch is REQUIRED to make any limit switch adjustments, even if a third party control system is used. Therefore, it is advised to wire the switch or provide a 3-conductor connection that is accessible.

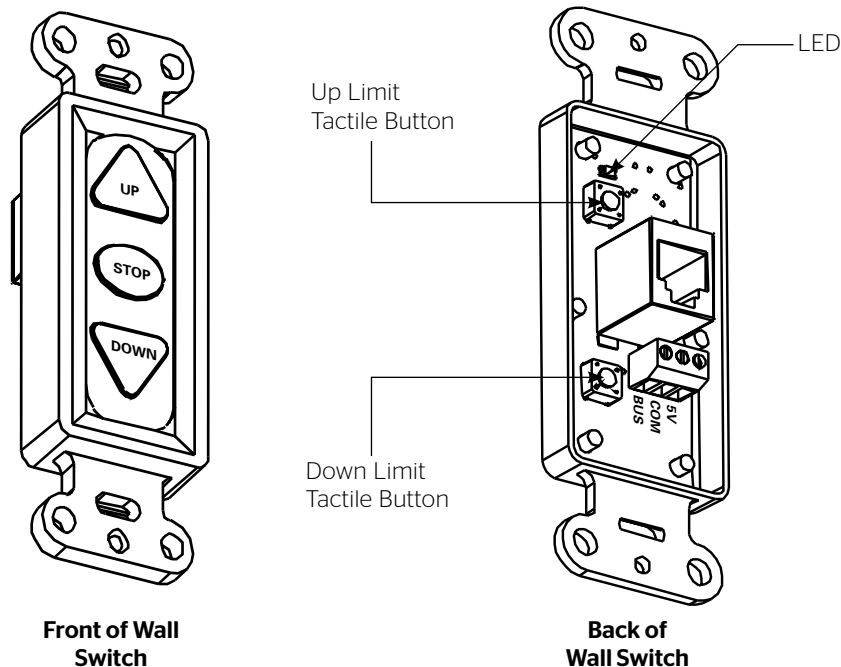

Screen Adjustment (continued)

For Screens with Optional SCB-100

Remove two screws to remove access door.

NOTE: Use a screwdriver or 5/32" Allen wrench to make adjustments.

SETTING THE DOWN LIMIT POSITION

To Reduce Screen Drop: Turn the "down" limit switch screw clockwise to decrease the amount of screen drop. Run the screen down to test the stop position. If the screen drops too far, raise the screen about one foot and adjust the limit switch again. Repeat until the desired position is set.

To Increase Screen Drop: Turn the "down" limit switch screw counterclockwise to increase the amount of screen drop. Run the screen down to test the stop position. If the screen does not drop enough, raise the screen about one foot and adjust the limit switch again. Repeat until the desired position is set. Do not adjust for more drop than what was ordered. At least 1-1/2 wraps of fabric must remain on the roller.

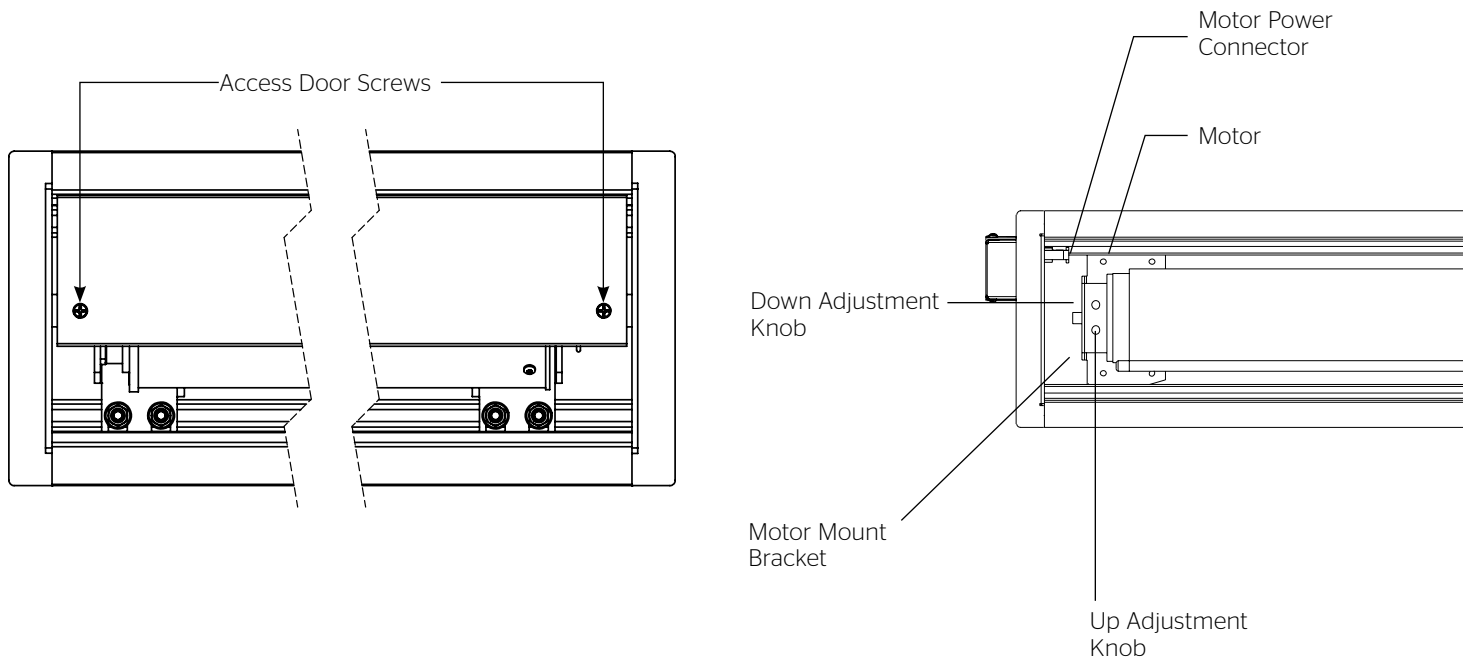

Operation of Screen

Operation & Limit Adjustment Wall Switch

1. Press "DOWN" button on screen switch and screen will deploy out of case in downward direction.
2. Press "STOP" button on screen switch and screen will stop if in movement.
3. Press "UP" button on screen switch and screen will retract upward into case.

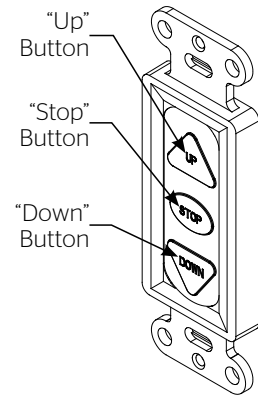

European Style Wall Switch (220V models only)

1. Press "DOWN" button on screen switch and screen will deploy out of case in downward direction.
2. Press "UP" button on screen switch and screen will retract upward into case.

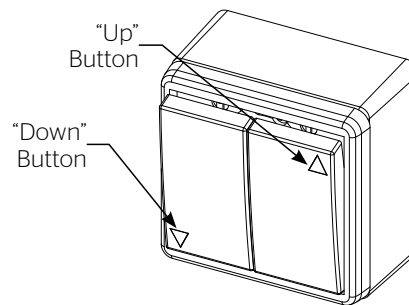

Third Party Control

Control Panel

A control panel may be connected to the splitter board by using the dry contact Up, Down and Common connections. The control panel must provide a momentary, dry contact closure of at least 1/2 second.

1. Use 3-conductor 20-24 gauge wire to connect the control panel to the splitter board.
2. A momentary closure across the common and up wires will be an "up" command.
3. A momentary closure across the common and down wires will be a "down" command.
4. A momentary closure across the common, up and down wires will be a "stop" command.

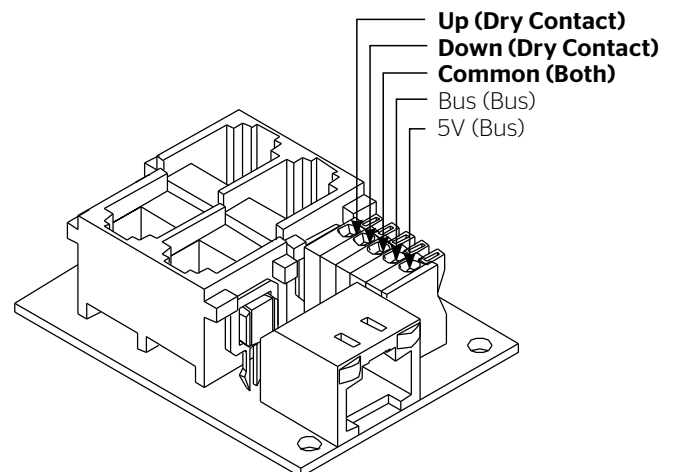

Troubleshooting

| Symptom | Cause | Solution |
|---|---|--|
| Screen will not operate and motor does not hum. | Incorrect line voltage. | Verify 115-125V (or 220-240V). If insufficient voltage, rewire incoming electric line. |
| | Blown fuse. | Replace fuse. |
| | Tripped circuit breaker. | Reset circuit breaker. |
| | No power to operating switch or junction. | Check above. Tighten all loose wire connections. Correct any improper connections. Down Position Check for power across black and white leads. Up Position Check for power across red and white leads. |
| Screen will not operate and motor does not hum. Power at junction box. | Thermal overload tripped. | Let motor cool down for 15 minutes. Try again. |
| | Broken wire in the "down" or "up" position. | Check for continuity. Cut off old splice and reconnect. |
| | Defective motor, limit switch or capacitor. | Replace motor assembly. NOTE: Motor is a sealed assembly. |
| | Capacitor burned out. | Replace motor assembly. |
| Screen does not stop at correct position. | Limit switch out of adjustment. | See Screen Adjustment section. |
| Noise. NOTE: Screen will operate with a low pitched hum. | Squeaking, rubber end plug rubbing on motor. | Center roller in case. |
| | Grinding. Foreign object in screen rubbing on roller or fabric. | Remove. |
| | Gear noise. | Replace motor assembly. |
| Coasting. | Defective brake. | Replace motor assembly. |
| Fabric hangs crooked. | Screen not installed properly. | Check for level and plumb. |
| | Fabric has backed up inside case. | Adjust "down" limit switch slowly until roller is exposed and wrinkle comes out, then readjust for proper drop. |
| | Fabric is damaged. | Replace fabric. |

Conditions for Transportation and Storage

- Temperature: Between 40 - 100°F (5 - 40°C)
- Relative Humidity: 30% to 70%, non-condensing
- Always keep the projection screen horizontal during transport and storage
- Make sure the entire package is supported when stored
- Do not stack more than six projection screens on top of each other
- Make sure the heaviest package is placed at the bottom of the stack

Screen surface should be allowed to air out once every two months, or otherwise used on a regular basis, if the temperature is above 72°F (22°C) and at least once every month if the temperature goes above 85°F (30°C).

LIMITED FIVE-YEAR WARRANTY ON DA-LITE PRESENTATION PRODUCTS

Legrand AV Inc. warrants certain Da-Lite branded products to the original purchaser only, to be free from defects in materials and workmanship for a period of five (5) years from the date of purchase by the original purchaser; provided they are properly operated according to Da-Lite's instructions and are not damaged due to improper handling or treatment after shipment from the factory.

Limited five-year warranty applies to the following products:

Wireline Advantage®, Tensioned Advantage Series, Advantage Series, Tensioned DescenderPro, DescenderPro, Tensioned Conference, Tensioned Professional, Professional, Da-Lift Projector Lifts, Tensioned Contour®, Contour, Tensioned Cosmopolitan® Series, Cosmopolitan Series, Designer Contour, Slimline, Studio, Arena, Motorized Scenic Roller, Ascender, Parallax®, Parallax Thin, FullVision, UTB Contour, Cinema Contour, Da-Snap, Perm-Wall, Imager, IDEA™ Screen, IDEA Panoramic, Fast-Fold® Deluxe, Fast-Fold Deluxe Drapery Kits, Flex Plex, Da-Glas, Da-Plex Rear Projection Mirror System, and Holo Screen.

This warranty does not apply to equipment showing evidence of misuse, abuse or accidental damage, or which has been tampered with or repaired by a person other than authorized Da-Lite personnel.

Da-Lite's sole obligation under this warranty shall be to repair or to replace (at Da-Lite's option) the defective part of the merchandise. Returns for service should be made to your Da-Lite dealer. If it is necessary for the dealer to return the screen or part to Da-Lite, transportation expenses to and from Da-Lite are payable by the purchaser and Da-Lite is not responsible for damage in shipment. To protect yourself against damage or loss in transit, insure the product and prepay all transportation expenses.

TO THE MAXIMUM EXTENT PERMITTED BY APPLICABLE LAW, THIS WARRANTY IS IN LIEU OF ALL OTHER WARRANTIES, EXPRESS OR IMPLIED, INCLUDING WARRANTIES AS TO FITNESS FOR USE AND MERCHANTABILITY. Any implied warranties of fitness for use, or merchantability, that may be mandated by statute or rule of law are limited to the five (5) year warranty period. This warranty gives you specific legal rights, and you may also have other rights, which vary from state-to-state. **TO THE MAXIMUM EXTENT PERMITTED BY APPLICABLE LAW, NO LIABILITY IS ASSUMED FOR EXPENSES OR DAMAGES RESULTING FROM INTERRUPTION IN OPERATION OF EQUIPMENT, OR FOR INCIDENTAL, DIRECT, OR CONSEQUENTIAL DAMAGES OF ANY NATURE.**

In the event that there is a defect in materials or workmanship of a Da-Lite product, you may contact Customer Care at 3100 North Detroit Street, Warsaw, IN 46582, (866) 977-3901.

IMPORTANT: THIS WARRANTY SHALL NOT BE VALID AND DA-LITE BRANDED PRODUCTS SHALL NOT BE BOUND BY THIS WARRANTY IF THE PRODUCT IS NOT OPERATED IN ACCORDANCE WITH THE DA-LITE WRITTEN INSTRUCTIONS.

Keep your sales receipt to prove the date of purchase and your original ownership.



FOR YOUR IMAGE | legrandav.com

| | | |
|--------|-------------------|--|
| USA | P 866.977.3901 | E av.da-lite.support@legrand.com |
| CANADA | P 877.345.4329 | E av.da-lite.support@legrand.com |
| EMEA | P +31 495 580 840 | E av.emea.sales@legrand.com |
| APAC | P +852 2145 4099 | E av.asia.sales@legrand.com |

© 2020 Legrand AV Inc. 200069 (Rev. 7) 3/20 Da-Lite is a registered trademark of Legrand AV Inc. All other brand names or marks are used for identification purposes and are trademarks of their respective owners. All patents are protected under existing designations. Other patents pending.



COMMERCIAL BRANDS

Chief | Da-Lite | Middle Atlantic | Projecta | Vaddio

84215



INSTRUCTION MANUAL

Tensioned Advantage®
(Over 14' W with Closure Door)



Original Instructions

Disclaimer

Legrand AV Inc. and its affiliated companies and subsidiaries (collectively, "Legrand AV"), intend to make this manual accurate and complete. However, Legrand AV makes no claim that the information contained herein covers all details, conditions or variations, nor does it provide for every possible contingency in connection with the installation or use of the products described herein. The content herein is subject to change without notice or obligation of any kind. To the maximum extent permitted by applicable law, Legrand AV makes no representation or warranty, expressed or implied, regarding the information contained herein. Furthermore, Legrand AV assumes no responsibility for accuracy, completeness or sufficiency of the information contained in this document.

Da-Lite® is a registered trademark of Legrand AV. All rights reserved.

Important Safety Instructions

When using your video equipment, basic safety precautions should always be followed, including the following:

1. Read and understand all instructions before using.
2. Close supervision is necessary when any appliance is used by or near children. Do not leave appliance unattended while in use.
3. Do not operate appliance with a damaged cord or if the appliance has been dropped or damaged - until it has been examined by a qualified serviceman.
4. Position the cord so that it will not be tripped over, pulled, or contact hot surfaces.
5. If an extension cord is necessary, a cord with a current rating at least equal to that of the appliance should be used. Cords rated for less amperage than the appliance may overheat.
6. To reduce the risk of electric shock, do not immerse this appliance in water or other liquids.
7. To reduce the risk of electric shock, do not disassemble this appliance. Contact an authorized service dealer when repair work is required. Incorrect reassembly can cause electric shock when the appliance is used subsequently.
8. The use of an accessory attachment not recommended by the manufacturer may cause a risk of fire, electric shock, or injury to persons.
9. Failure to provide adequate structural strength for this component can result in serious personal injury or damage to equipment! It is the installer's responsibility to make sure the structure to which this component is attached can support the weight of all equipment. Reinforce the structure as required before installing the component.
10. Use this projection screen only for its intended use as described in these instructions. Do not use attachments not recommended by the manufacturer.

Save These Instructions

Tools Required for Installation

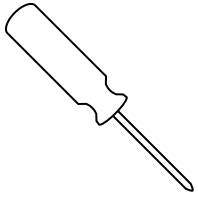

#2 Phillips Screwdriver

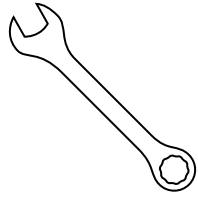

3/4" Open Wrench
or Socket Driver

Pre-Installation

1. Carefully unpack screen and remove outer wrapping from case.
2. Make sure to recheck measurements of screen location before installation.

PLEASE NOTE: Motor Operator Projection Screen Models LADT, LADDT, LAD and LADD must be installed in accordance with the requirements of the Local Building Codes, the Canadian Electrical Code (CEC), CAN/CSA C22.1 and the National Electric Code (NEC), NFPA 70. An appropriate disconnect device shall be provided as part of the building installation.

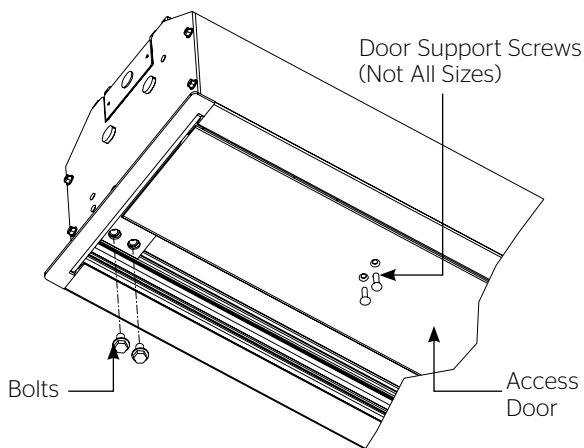

Figure 1

Case Installation

1. The case provides multiple attachment points for bolts, cables, or threaded rod. Page 5 shows threaded rod installed. The variable position-mounting bracket may be located anywhere along the length of the case. It is recommended to keep the brackets spaced evenly enough to distribute the weight of the screen. One mounting bracket is required for every 4' of case length.

The case has a self-trimming flange around the bottom. Ceiling tiles or drywall may be placed on top of this flange to provide a finished appearance.

2. After securing the case in the ceiling check that the case is level and plumb.
3. Use supplied 1/8" hex key to remove silver shipping brackets attached to slat and screen case.
4. Install electrical connections that apply to your unit. Review the wiring diagrams for proper installation.

Tensioned Advantage (Over 14' W with Closure Door) Installation

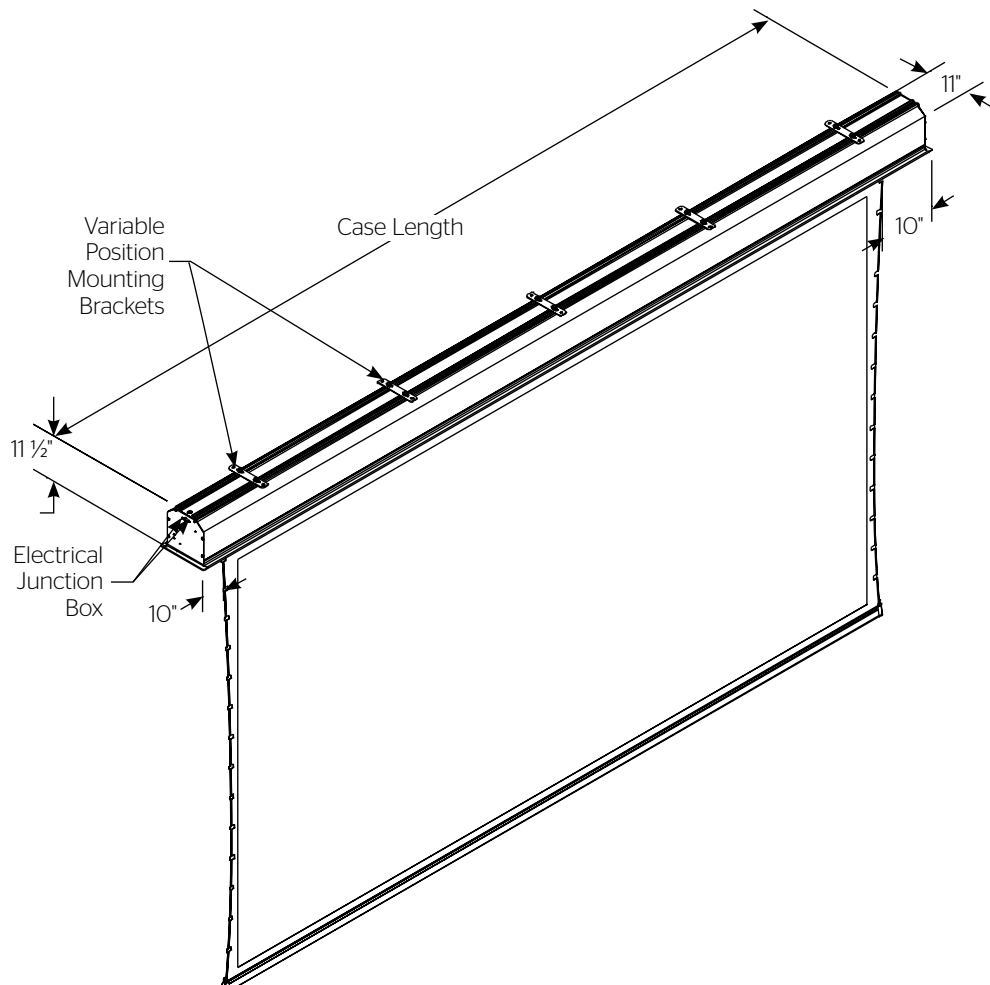
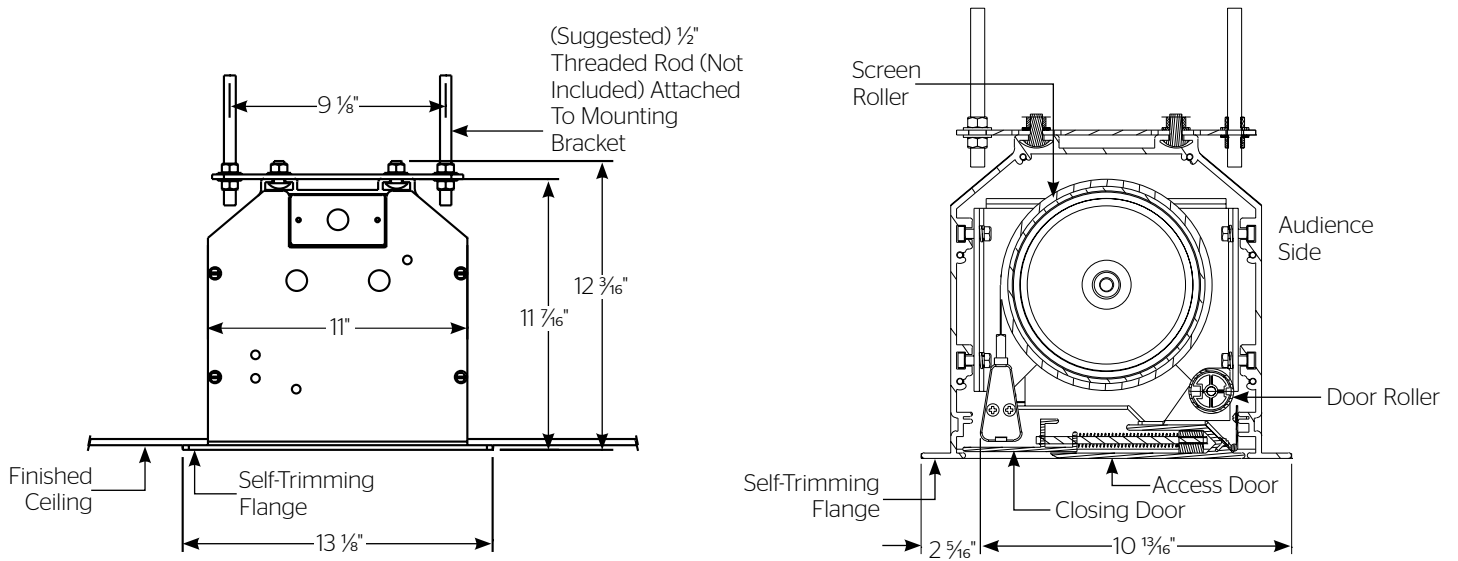

Tensioned Advantage (Over 14' W with Closure Door) Instructions

120V Wiring Diagram

NOTE: Electrical connections on left end of case.

Use provided knockouts for all electrical connections. DO NOT drill additional holes into screen case or end cap.

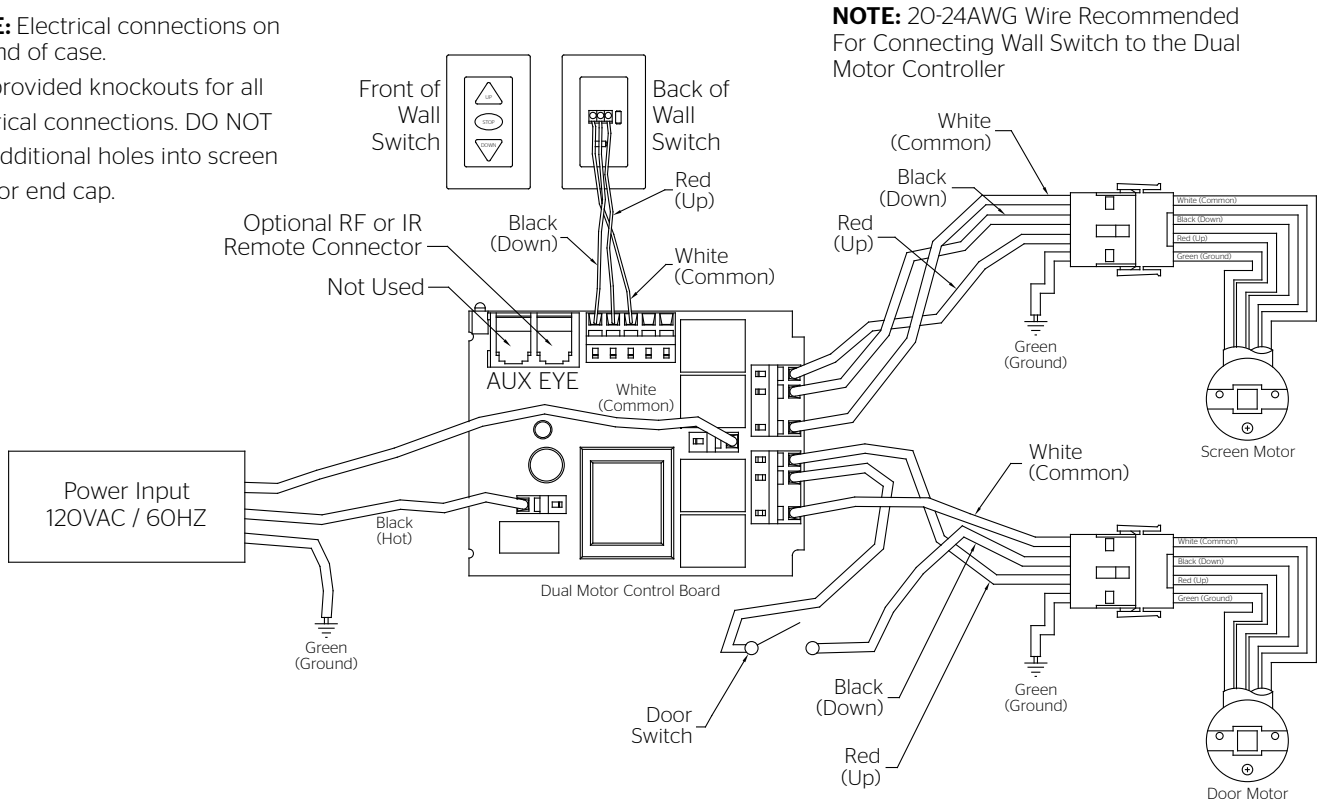

220V Wiring Diagram

NOTE: Electrical connections on left end of case.

Use provided knockouts for all electrical connections. DO NOT drill additional holes into screen case or end cap.

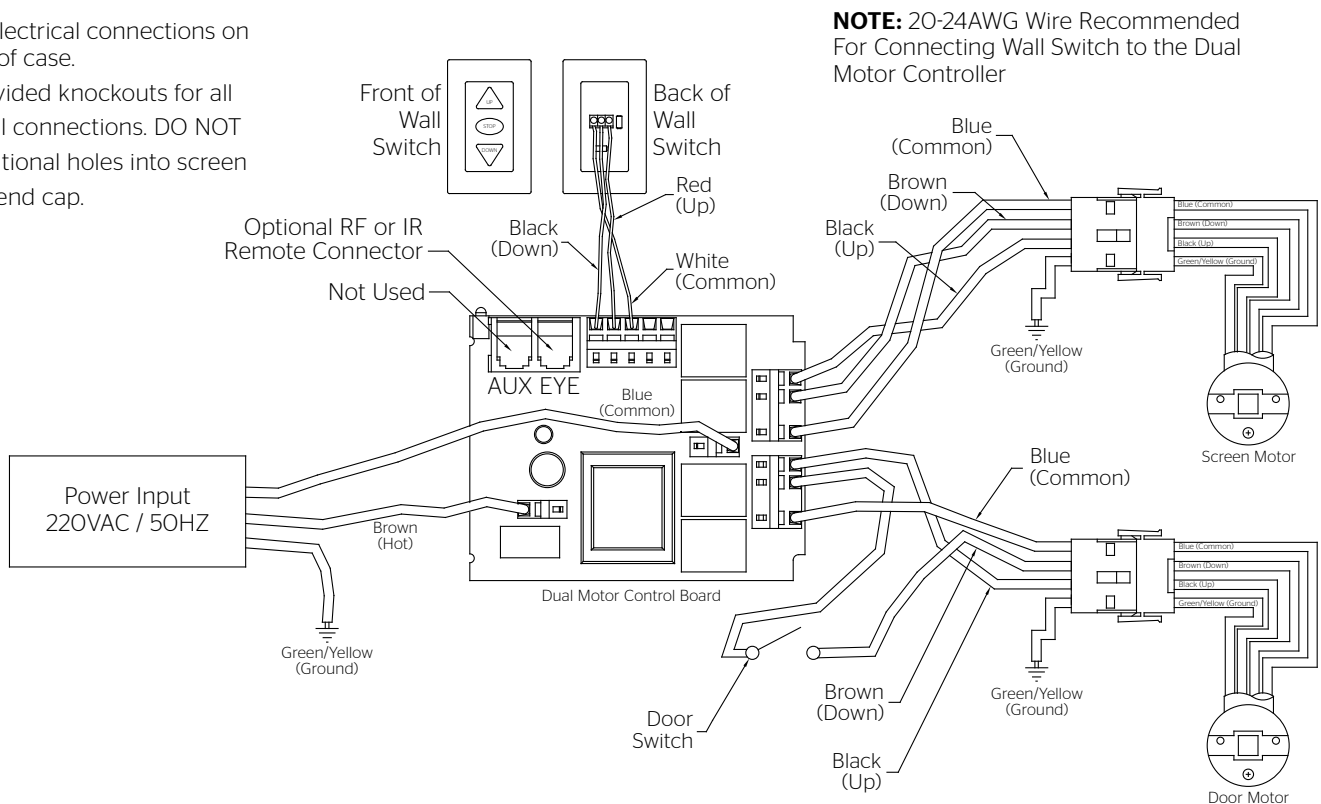

Screen And Roller Assembly Installation

If your screen was shipped with the motor and roller already installed proceed to step 9.

1. Remove four bolts from ends of door assembly (2 bolts on each end) (Fig. 1). This will allow the door assembly to drop open for access to case. For larger sizes, you will also need to remove the door support screws.
2. Carefully unpack screen and roller assembly. Leave packing paper on the roller.
3. Remove the square peg bracket from the motor end of the roller assembly.
4. Remove the safety clip from the motor attachment bracket located in the motor end of the screen housing.
5. Place the roller assembly into the case with the motor on the left side. The limit switches should be facing down. Line up the head of the motor with the motor attachment bracket.
6. Loosen four bolts that secure pin end mounting bracket into housing. Lift pin end of roller into position and slide the bracket into the roller pin. Tighten all four bolts.
7. Complete electrical hook-up by snapping motor 1/3 wire connectors into case connectors.
8. Return to motor end and insert safety clip over casting bracket to secure motor end.

⚠ CAUTION! Do not cut tape on fabric with a knife or any sharp tool. Remove by hand.

⚠ ATTENTION! Ne coupez pas le ruban adhésif sur la toile avec un couteau ou un outil tranchant. Retirez à la main.

9. Carefully remove tape strips securing picture surface around roller. Slat should move freely (Fig. 2). (Only if the roller assembly is pre installed.)
10. Test installation by operating the screen several times. Be prepared to stop the screen. The door assembly will not close until the wall switch is placed in the up position and when the screen motor stops at its limit switch in the up direction.

NOTE: Unit duty cycle is 1 minute on, 3 minutes off.

NOTE: Excessive continuous operation may cause the motor to overheat. If this happens the motor will shut off until it cools to a normal operating temperature.

11. Close door assembly and replace four bolts at ends of door (2 bolts on each end) (Fig. 1).

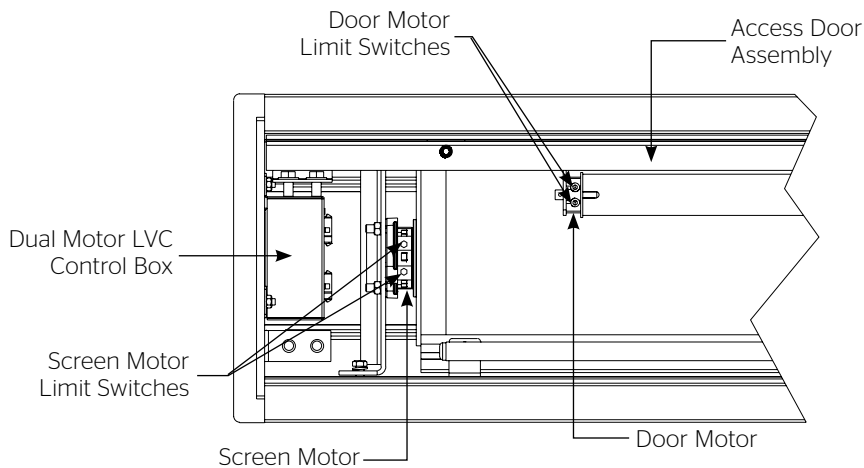

Figure 2

Screen Adjustment

Surface travel is stopped automatically in the fully opened and closed positions by limit switches that are properly adjusted at Da-Lite. Should it be necessary to adjust for more or less drop of picture, proceed in the following manner:

NOTE: Use a screw driver or 5/32" Allen wrench to make adjustments.

More Screen Drop

1. Place operating switch in **"down"** position.
2. When the screen stops, turn the white **"down"** limit knob one-quarter turn counterclockwise. Test by raising picture surface approximately two feet, then lower again. Repeat until desired picture surface position is attained.

▲ CAUTION: Do not adjust for more drop than what was ordered. At least 1-1/2 wraps of fabric must remain on the roller. This screen comes standard with 12" black at the top.

▲ ATTENTION! N'effectuez pas de réglage pour obtenir un déroulement supérieur à celui commandé. Au moins 1 à 1/2 tour de toile doit être maintenu sur le cylindre. Ce écran est doté de série d'une bande noire supérieure de 30,5 cm (12 po).

Less Screen Drop

1. Raise picture surface approximately two feet above desired level.
2. Place operating switch in **"off"** position.
3. Turn the white **"down"** limit switch one-quarter turn clockwise. Test by raising picture surface approximately two feet, then lower again. Repeat until desired picture surface position is attained.

▲ CAUTION: Adjusting the down limit switch for less drop by more than 6" can cause the screen surface to lose proper tensioning.

▲ ATTENTION! LE FAIT D'AJOUTER NE DÉROULEZ PAS TROP L'ÉCRAN PLUS DE 15 CM (6PO) AUX INTERRUPTEURS DE FIN DE COURSE PEUT FAIRE PERDRE LA BONNE TENSION À LA SURFACE DE L'ÉCRAN.

Door Motor Adjustment

▲ CAUTION: Contact Da-Lite at 800-622-3737 or 574-267-8101 if door motor needs adjustment.

▲ ATTENTION! Contactez Da-Lite au 800-622-3737 ou au 574-267-8101 au cas le moteur de l'écran a besoin d'être ajusté.

Troubleshooting

| Symptom | Cause | Solution |
|---|--|---|
| Screen will not operate or will not go "down." Motor does not hum. | Incorrect line voltage. | Verify 115-125V (or 220-240V). If insufficient voltage, rewire incoming electric line. |
| | Blown facility fuse. | Replace facility fuse. |
| | Tripped facility circuit breaker. | Reset facility circuit breaker. |
| | No power to operating switch or junction box. | Check above. Tighten all loose wire connections. Recheck wiring. See installation instructions. |
| | Low voltage board has no power or blown transformer. | Replace low voltage board. "Down" Position. Check for power across black and white leads. |
| | Power at junction box. Thermal overload tripped. | Let motor cool down for 15 minutes. Try again. |
| | Broken wire in the "down" position. | Check for continuity. |
| | Defective motor, limit switch or capacitor. | Replace motor assembly. NOTE: Motor is a sealed assembly. |
| Motor hums. | Capacitor burned out. | Replace motor assembly. |
| Screen will not move upward. Motor does not hum. | Incorrect line voltage. | Verify 115-125V (or 220-240V). If insufficient voltage, rewire incoming electric line. |
| | Blown facility fuse. | Replace facility fuse. |
| | Tripped facility circuit breaker. | Reset facility circuit breaker. |
| | No power to operating switch or junction box. | Check above. Tighten all loose wire connections. See above. |
| | Low voltage board has no power or blown transformer. | Replace low voltage board. "Up" Position. Check for power across red and white leads. |
| | Open door limit switch. | Replace switch. |
| | Power at junction box. Thermal overload tripped. | Let motor cool down for 15 minutes. Try again. |
| | Broken wire in the "up" position. | Check for continuity. |
| | Defective motor, limit switch or capacitor. | Replace motor assembly. NOTE: Motor is a sealed assembly. |
| | Motor hums. | Capacitor burned out. |

Troubleshooting (continued)

| Symptom | Cause | Solution |
|---|--|--|
| Door will not open. | Spring has an obstruction not allowing door to open. | Check installation to free door. Clear any foreign substance from spring. |
| | No power. | See above. |
| Door does not close. | Mis-adjusted door motor limit. | Adjust door motor limit. Call Da-Lite for instruction. |
| | Low voltage board has no power or a blown transformer. | Replace low voltage board. |
| "Down" limit switch incorrect. | "Down" limit switch out of adjustment. | See installation instructions. |
| Noise. NOTE: Screen will operate with a low-pitched hum. | Buzzing noise. | Adjust door limit switch (too far down). |
| | Gear noise. | Replace motor assembly. |
| Coasting. | Defective brake. | Replace motor assembly. |
| Roller displaced from mounting bracket. | Pin end slipped out of nylon bearing. | Realign pin end bracket. |
| Fabric hangs crooked. | Screen not installed properly. | Check for level and plumb. |
| | Fabric is damaged. | Replace fabric. |
| Door closes before screen is all the way up. | Screen "up" limit out of adjustment. | Adjust "up" limit (call factory for instructions). |
| Door opens but screen does not operate. | Loose wire. | Check all wiring and connections. |

Conditions for Transportation and Storage

- Temperature: Between 40 - 100°F (5 - 40°C)
- Relative Humidity: 30% to 70%, non-condensing
- Always keep the projection screen horizontal during transport and storage
- Make sure the entire package is supported when stored
- Do not stack more than six projection screens on top of each other
- Make sure the heaviest package is placed at the bottom of the stack

Screen surface should be allowed to air out once every two months, or otherwise used on a regular basis, if the temperature is above 72°F (22°C) and at least once every month if the temperature goes above 85°F (30°C).

LIMITED FIVE-YEAR WARRANTY ON DA-LITE PRESENTATION PRODUCTS

Legrand AV Inc. warrants certain Da-Lite branded products to the original purchaser only, to be free from defects in materials and workmanship for a period of five (5) years from the date of purchase by the original purchaser; provided they are properly operated according to Da-Lite's instructions and are not damaged due to improper handling or treatment after shipment from the factory.

Limited five-year warranty applies to the following products:

Wireline Advantage®, Tensioned Advantage Series, Advantage Series, Tensioned DescenderPro, DescenderPro, Tensioned Conference, Tensioned Professional, Professional, Da-Lift Projector Lifts, Tensioned Contour®, Contour, Tensioned Cosmopolitan® Series, Cosmopolitan Series, Designer Contour, Slimline, Studio, Arena, Motorized Scenic Roller, Ascender, Parallax®, Parallax Thin, FullVision, UTB Contour, Cinema Contour, Da-Snap, Perm-Wall, Imager, IDEA™ Screen, IDEA Panoramic, Fast-Fold® Deluxe, Fast-Fold Deluxe Drapery Kits, Flex Plex, Da-Glas, Da-Plex Rear Projection Mirror System, and Holo Screen.

This warranty does not apply to equipment showing evidence of misuse, abuse or accidental damage, or which has been tampered with or repaired by a person other than authorized Da-Lite personnel.

Da-Lite's sole obligation under this warranty shall be to repair or to replace (at Da-Lite's option) the defective part of the merchandise. Returns for service should be made to your Da-Lite dealer. If it is necessary for the dealer to return the screen or part to Da-Lite, transportation expenses to and from Da-Lite are payable by the purchaser and Da-Lite is not responsible for damage in shipment. To protect yourself against damage or loss in transit, insure the product and prepay all transportation expenses.

TO THE MAXIMUM EXTENT PERMITTED BY APPLICABLE LAW, THIS WARRANTY IS IN LIEU OF ALL OTHER WARRANTIES, EXPRESS OR IMPLIED, INCLUDING WARRANTIES AS TO FITNESS FOR USE AND MERCHANTABILITY. Any implied warranties of fitness for use, or merchantability, that may be mandated by statute or rule of law are limited to the five (5) year warranty period. This warranty gives you specific legal rights, and you may also have other rights, which vary from state-to-state. **TO THE MAXIMUM EXTENT PERMITTED BY APPLICABLE LAW, NO LIABILITY IS ASSUMED FOR EXPENSES OR DAMAGES RESULTING FROM INTERRUPTION IN OPERATION OF EQUIPMENT, OR FOR INCIDENTAL, DIRECT, OR CONSEQUENTIAL DAMAGES OF ANY NATURE.**

In the event that there is a defect in materials or workmanship of a Da-Lite product, you may contact Customer Care at 3100 North Detroit Street, Warsaw, IN 46582, (866) 977-3901.

IMPORTANT: THIS WARRANTY SHALL NOT BE VALID AND DA-LITE BRANDED PRODUCTS SHALL NOT BE BOUND BY THIS WARRANTY IF THE PRODUCT IS NOT OPERATED IN ACCORDANCE WITH THE DA-LITE WRITTEN INSTRUCTIONS.

Keep your sales receipt to prove the date of purchase and your original ownership.



FOR YOUR IMAGE | legrandav.com

USA P 866.977.3901 E av.da-lite.support@legrand.com
CANADA P 877.345.4329 E av.da-lite.support@legrand.com
EMEA P +31 495 580 840 E av.emea.sales@legrand.com
APAC P +852 2145 4099 E av.asia.sales@legrand.com

© 2020 Legrand AV Inc. 200073 (Rev. 2) 3/20 Da-Lite is a registered trademark of Legrand AV Inc. All other brand names or marks are used for identification purposes and are trademarks of their respective owners. All patents are protected under existing designations. Other patents pending.



COMMERCIAL BRANDS

Chief | Da-Lite | Middle Atlantic | Projecta | Vaddio

35898



INSTRUCTION MANUAL
Tensioned Advantage®
(Over 14' W)



Original Instructions

Disclaimer

Legrand AV Inc. and its affiliated companies and subsidiaries (collectively, "Legrand AV"), intend to make this manual accurate and complete. However, Legrand AV makes no claim that the information contained herein covers all details, conditions or variations, nor does it provide for every possible contingency in connection with the installation or use of the products described herein. The content herein is subject to change without notice or obligation of any kind. To the maximum extent permitted by applicable law, Legrand AV makes no representation or warranty, expressed or implied, regarding the information contained herein. Furthermore, Legrand AV assumes no responsibility for accuracy, completeness or sufficiency of the information contained in this document.

Da-Lite® is a registered trademark of Legrand AV. All rights reserved.

Important Safety Instructions

When using your video equipment, basic safety precautions should always be followed, including the following:

1. Read and understand all instructions before using.
2. Position the cord so that it will not be tripped over, pulled, or contact hot surfaces.
3. If an extension cord is necessary, a cord with a current rating at least equal to that of the appliance should be used. Cords rated for less amperage than the appliance may overheat.
4. To reduce the risk of electric shock, do not disassemble this appliance. Contact an authorized service dealer when repair work is required. Incorrect reassembly can cause electric shock when the appliance is used subsequently.
5. The use of an accessory attachment not recommended by the manufacturer may cause a risk of fire, electric shock, or injury to persons.
6. Failure to provide adequate structural strength for this component can result in serious personal injury or damage to equipment! It is the installer's responsibility to make sure the structure to which this component is attached can support the weight of all equipment. Reinforce the structure as required before installing the component.
7. Use this projection screen only for its intended use as described in these instructions. Do not use attachments not recommended by the manufacturer.

Save These Instructions

Tools Required for Installation

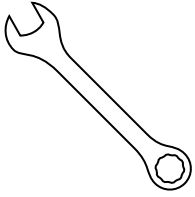

3/4" Open Wrench
or Socket Driver

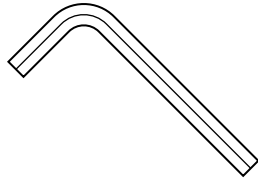

1/8" Hex Key
(included)

Pre-Installation

1. Carefully unpack case from shipping crate.
2. Set aside the Installation Kit. Items inside will be used during installation.
3. Make sure to recheck measurement of case for proper installation clearance.
4. Remove any protective foam from case.
5. If necessary, adjust hanger brackets with a 3/4" open wrench or socket driver.

Case Installation

1. The case provides multiple attachment points for bolts, cables, or threaded rod. Page 4 shows threaded rod installed. The variable position-mounting bracket may be located anywhere along the length of the case. It is recommended to keep the brackets spaced evenly enough to distribute the weight of the screen. One mounting bracket is required for every 4' of case length.

2. Tighten bolts until trim flange is flush with ceiling.

NOTE: For proper operation, screen assembly must be level after installation.

3. Remove 2 screws to open junction box. Install electrical connections that apply to your unit. Make sure to review the wiring diagram for proper hook up. Replace junction box cover and secure with 2 screws.

NOTE: Please Note: Motor Operator Projection Screen Models LADT, LADDT, LAD and LADD must be installed in accordance with the requirements of the Local Building Codes, the Canadian Electrical Code (CEC), CAN/CSA C22.1 and the National Electric Code (NEC), NFPA 70. An appropriate disconnect device shall be provided as part of the building installation.

If your case was ordered in advance of the screen and roller assembly, your installation is now complete. Continue to step 4 if your Tensioned Advantage (Over 14' W) was ordered as a complete unit.

4. Carefully remove paper and tape from roller assembly

⚠ CAUTION! Do not use a knife or sharp object to cut tape; you will damage the screen. Pull orange string.

⚠ ATTENTION! Ne coupez pas le ruban adhésif sur la toile avec un couteau ou un outil tranchant. Retirez à la main.

5. Use supplied 1/8" hex key to remove silver shipping brackets attached to slat and screen case.
6. Test installation by running screen up and down a few times. Be prepared to stop screen should any objects obstruct the movement of the screen. To prevent damage to the motor, the standard duty cycle is 1 minute on and 3 minutes off.

Screen And Roller Assembly Installation

Tools required for screen and roller assembly:

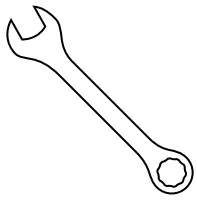

9/16" Open Wrench
or Socket Driver

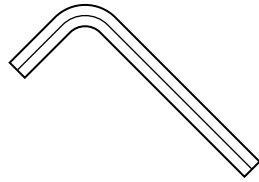

5/32" Hex Key

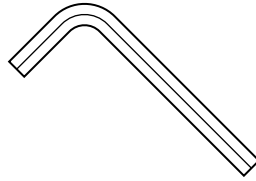

1/8" Hex Key
(included)

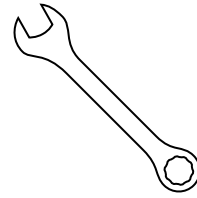

1/2" Open Wrench
or Socket Driver

If your screen was shipped with the motor and roller already installed proceed to step 7.

1. Remove the access door. First, remove the 2 bolts from each end with a 9/16" open wrench or socket driver. Next, use a 5/32" hex key to remove the two screws in the center of the access door. This will allow the door to drop open on the hinges (Figure 1).
2. Carefully unpack screen and roller assembly. Use supplied 1/8" hex key to remove shipping brackets attached to slat. Remove fabric and roller assembly from shipping board using a 1/2" wrench. Leave packing paper on roller.
3. Remove the square peg bracket from the motor end of the roller assembly (Figure 2).
4. Remove the safety clip from the motor attachment bracket located in the motor end of the screen housing.
5. Use a 1/2" open wrench or socket driver to loosen the four bolts that secure pin end mounting bracket into housing. Lift pin end of roller into position and slide the bracket into the roller pin. Tighten all four bolts. Slide the pin end bracket towards the end of the case (Figure 3).
6. Place the roller assembly into the case with the motor on the left side. The limit switches should be facing down. Line up the head of the motor with the motor attachment bracket.
7. Complete electrical hook-up by snapping motor 1/3 wire connectors into case connectors (Figure 2).
8. Return to motor end and insert safety clip over casting bracket to secure motor end.
9. Carefully remove tape strips securing picture surface around roller. Slat should move freely. (Only if the roller assembly is pre installed.)

⚠ CAUTION! Do not cut tape on fabric with a knife or any sharp tool. Remove by hand.

⚠ ATTENTION! Ne coupez pas le ruban adhésif sur la toile avec un couteau ou un outil tranchant. Retirez à la main.

10. Test installation by running screen up and down a few times. Be prepared to stop screen should any objects obstruct the movement of the screen. To prevent damage to the motor, the standard duty cycle is 1 minute on and 3 minutes off.
11. Re-install the access door. Procedure is the reverse of step 1 listed above.

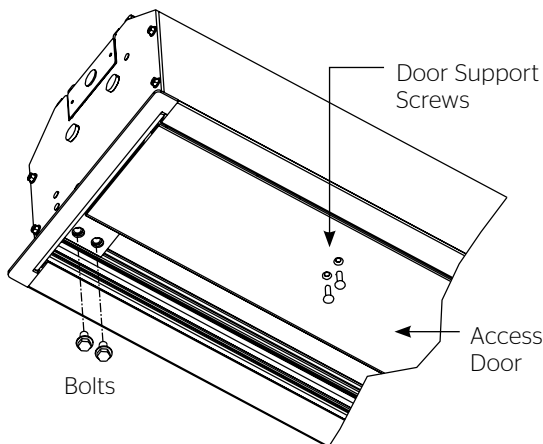

Figure 1

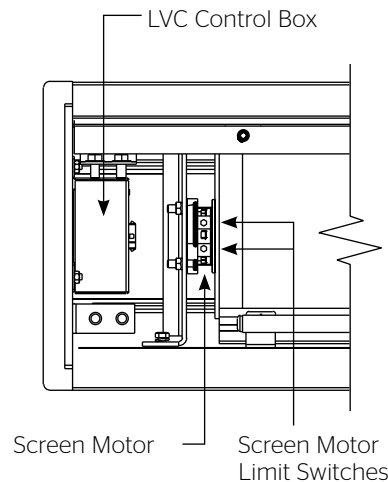

Figure 2

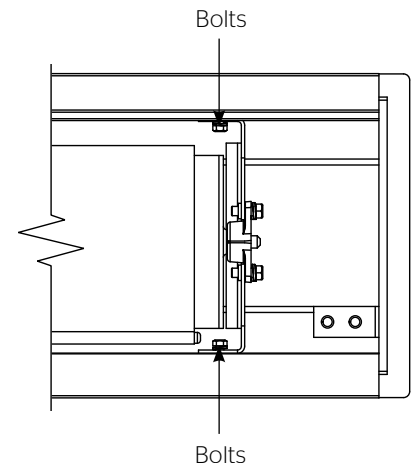
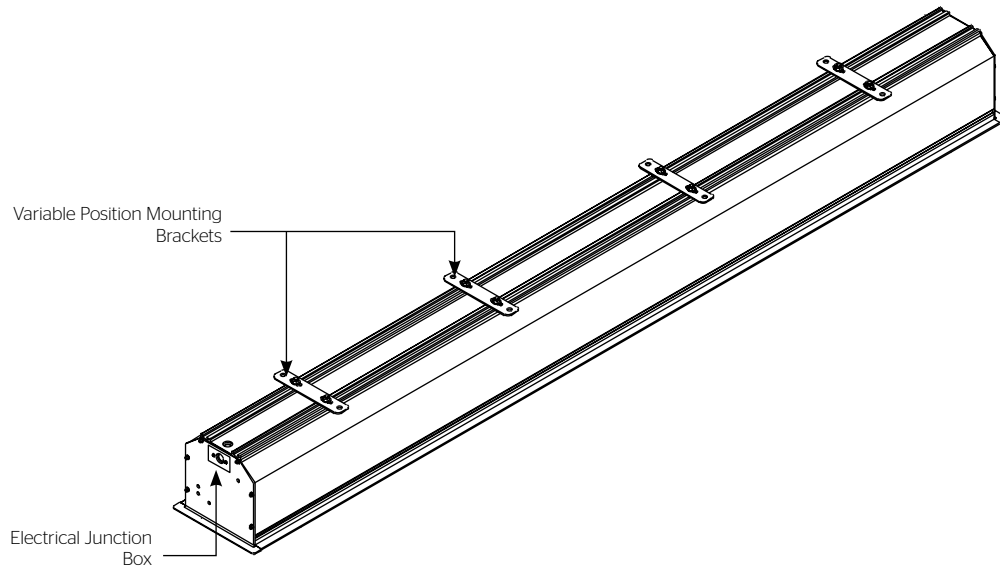
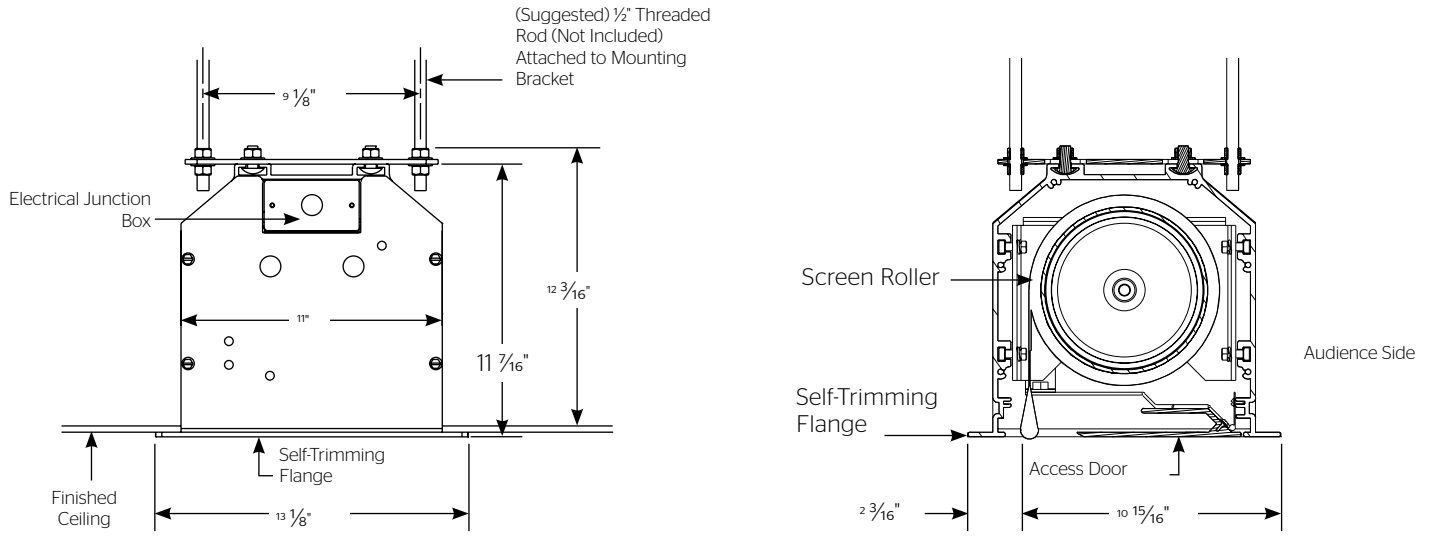

Figure 3

Tensioned Advantage (Over 14' W) Installation



Screen Adjustment

Surface travel is stopped automatically in the fully opened and closed positions by limit switches that are properly adjusted at Da-Lite. Should it be necessary to adjust for more or less drop of picture, proceed in the following manner:

NOTE: Use a screw driver or 5/32" Allen wrench to make adjustments.

More Screen Drop

1. Place operating switch in "down" position.
2. When the screen stops, turn the white "down" limit knob (Figure 4) one-quarter turn counterclockwise. Test by raising picture surface approximately two feet, then lower again. Repeat until desired picture surface position is attained.

⚠ CAUTION: Do not adjust for more drop than what was ordered. At least 1-1/2 wraps of fabric must remain on the roller. This screen comes standard with 12" black at the top.

⚠ ATTENTION! N'effectuez pas de réglage pour obtenir un déroulement supérieur à celui commandé. Au moins 1 à 1/2 tour de toile doit être maintenu sur le cylindre. Ce écran est doté de série d'une bande noire supérieure de 30,5 cm (12 po).

Less Screen Drop

1. Raise picture surface approximately two feet above desired level.
2. Place operating switch in "off" position.
3. Turn the white "down" limit switch (Figure 4) one-quarter turn clockwise. Test by raising picture surface approximately two feet, then lower again. Repeat until desired picture surface position is attained.

⚠ Caution: Adjusting the down limit switch for less drop by more than 6" can cause the screen surface to lose proper tensioning.

⚠ ATTENTION! Le fait d'ajouter ne déroulez pas trop l'écran plus de 15 cm (6po) aux interrupteurs de fin de course peut faire perdre la bonne tension à la surface de l'écran.

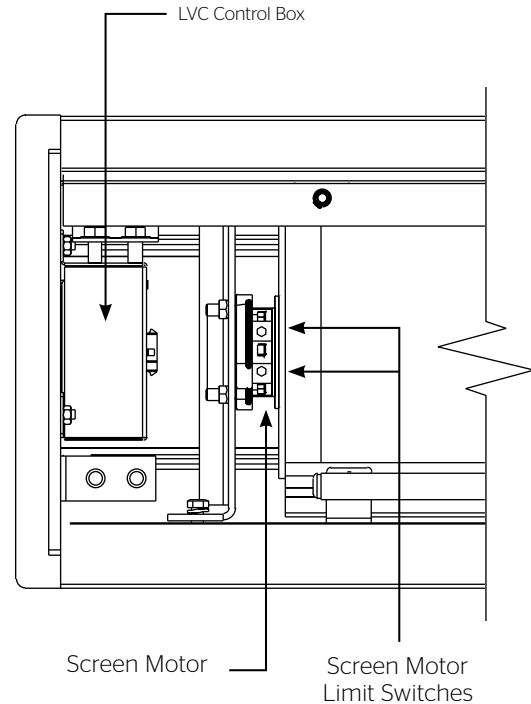

Figure 4

120V Wiring Diagram

NOTE: 20-24 AWG wire recommended for connecting wall switch to low voltage controller.

CAUTION: Do not use 3-position high voltage rocker switch with this unit! This will damage the low voltage control board.

ATTENTION: NE UTILISEZ PAS l'interrupteur à bascule fourni avec l'écran. Le tableau de contrôle basse tension sera endommagé.

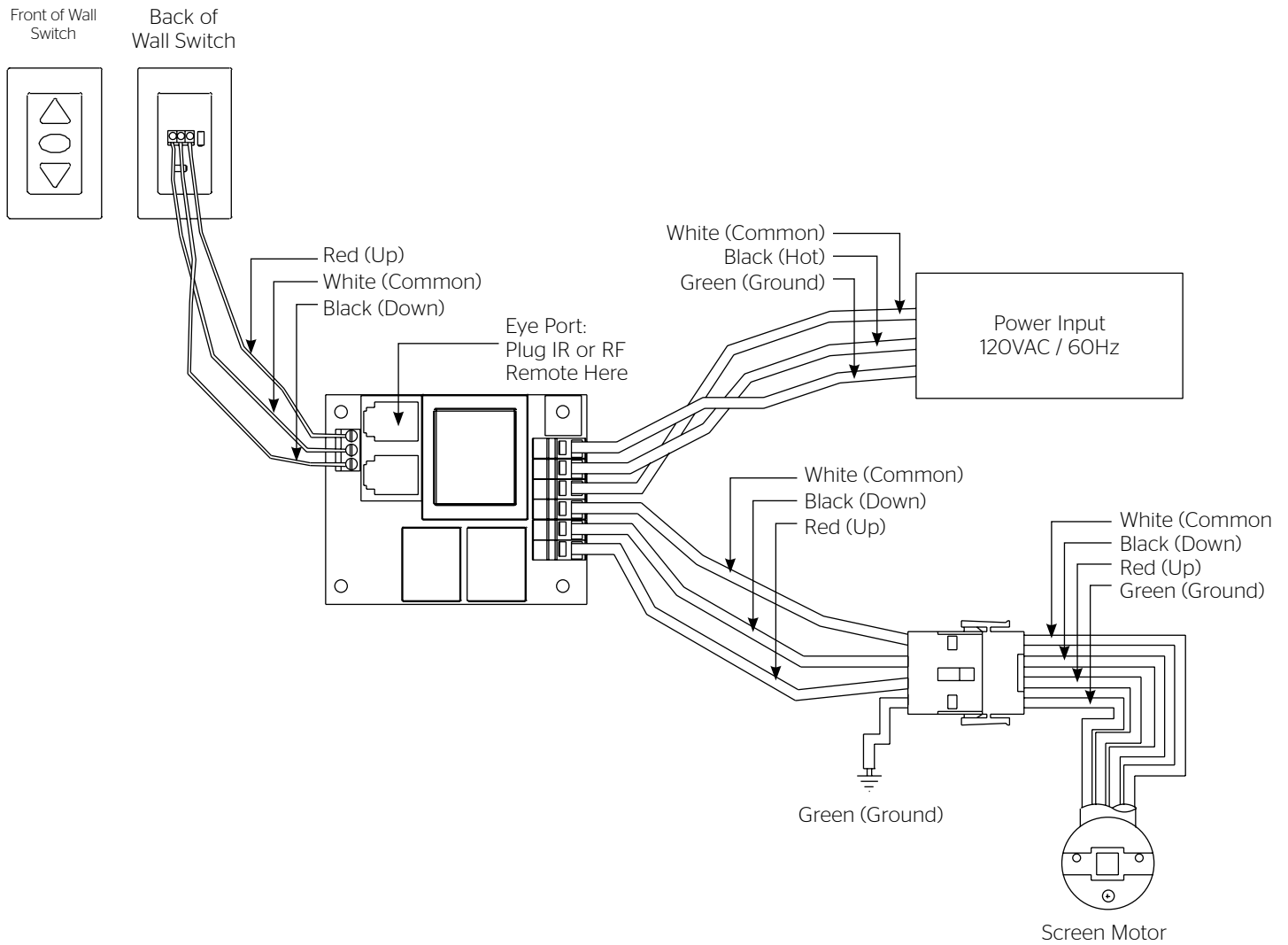

240V Wiring Diagram

NOTE: 20-24 AWG wire recommended for connecting wall switch to low voltage controller.

⚠ CAUTION: Do not use 3-position high voltage rocker switch with this unit! This will damage the low voltage control board.

⚠ ATTENTION: NE UTILISEZ PAS l'interrupteur à bascule fourni avec l'écran. Le tableau de contrôle basse tension sera endommagé.

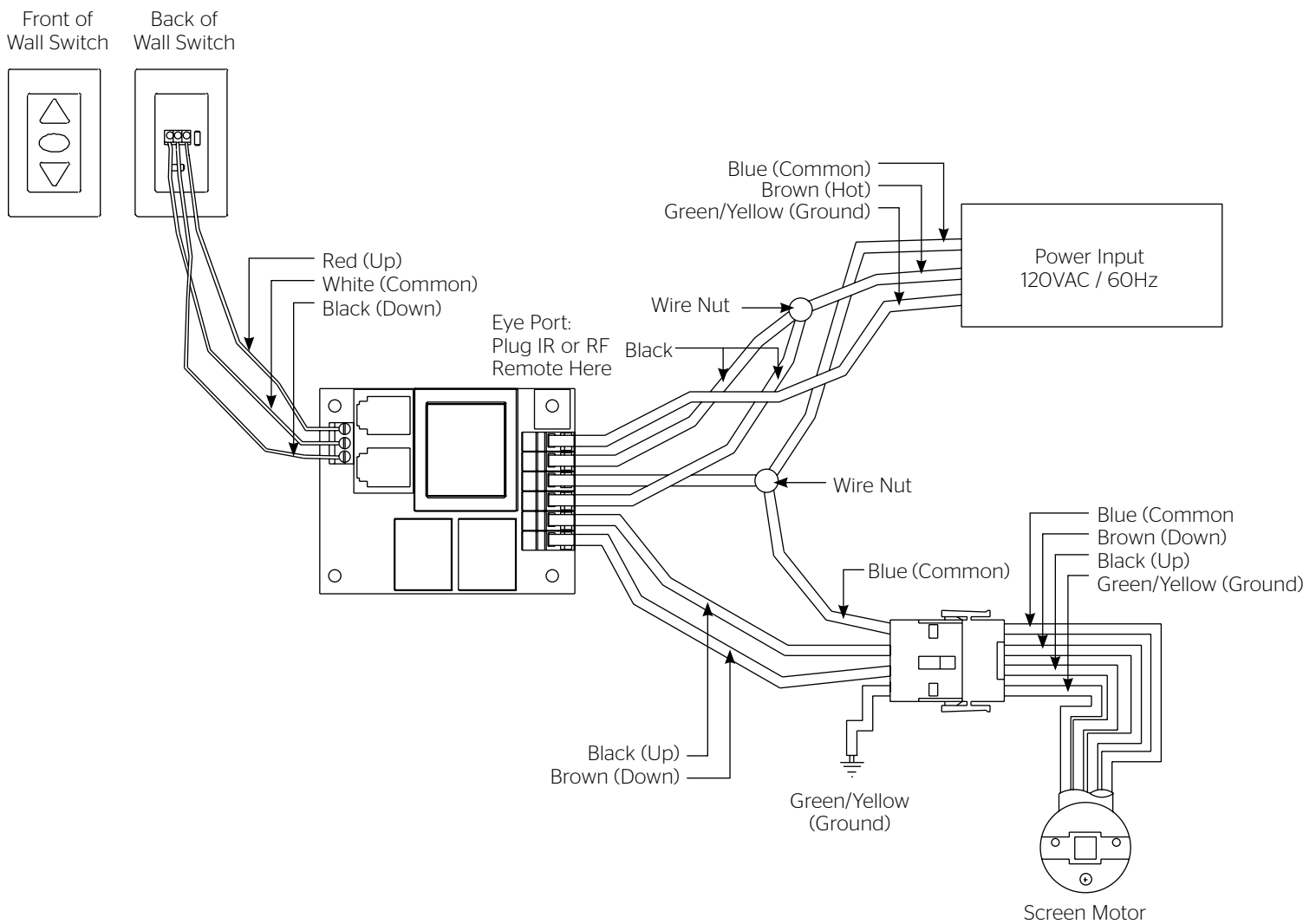

120V Wiring Diagram with Optional SCB-100 Control

NOTE: Electrical connections on left end of case.

Use provided knockouts for all electrical connections. DO NOT drill additional holes into screen case or end cap.

Recommended Wire Size:

Wall Switch: 20-24 AWG

Motor: 14-18 AWG

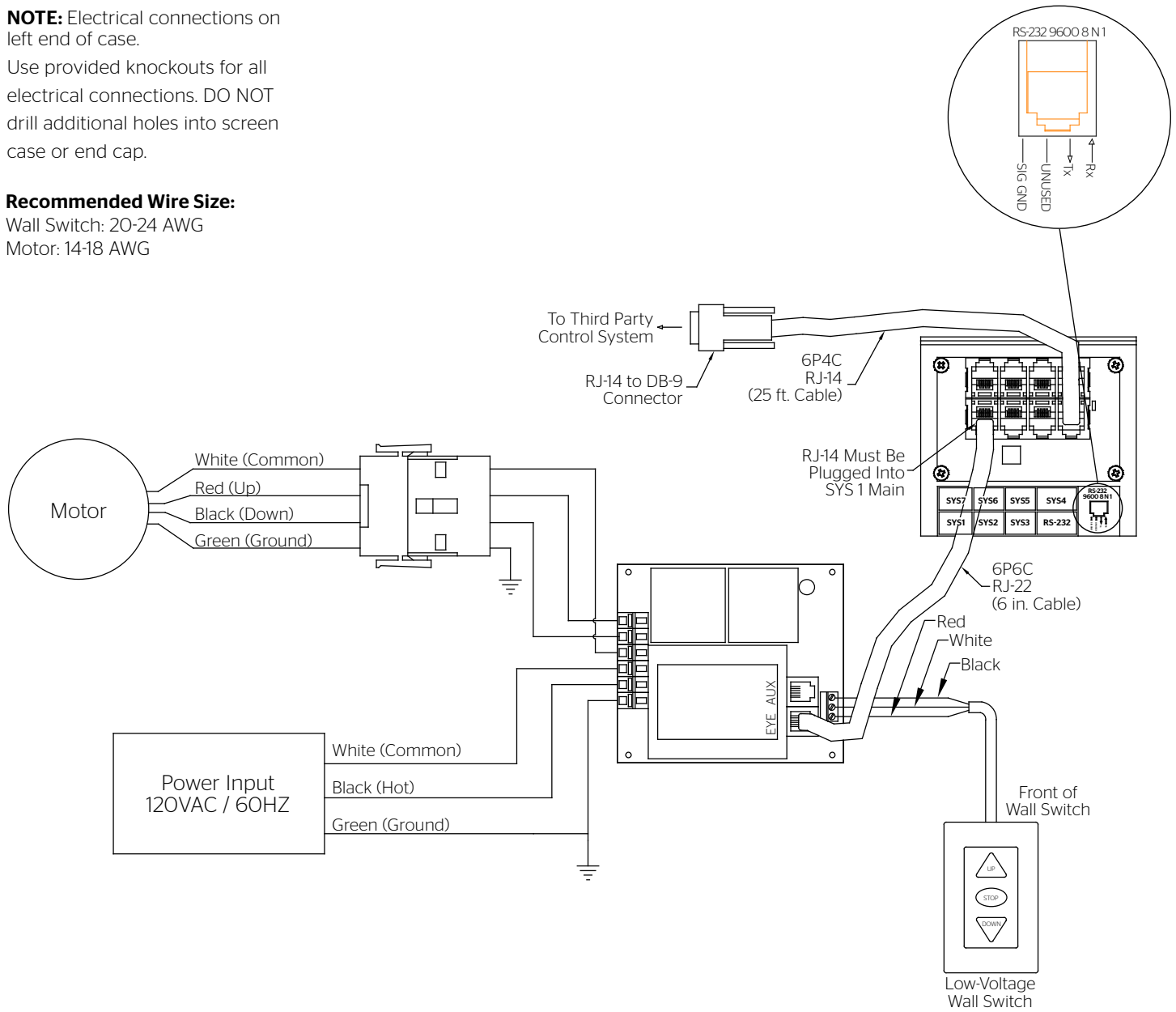

Communication Instructions

The connection settings for the SCB-100 are 9600 Baud Rate, 8 Data Bits, None Parity, 1 stop bit and XON/XOFF Flow Control. The control is NOT Bi-Directional, but it will give a response to commands sent.

1. When the SCB-100 unit first powers on it will send back the (Version, X-on). The LED on the SCB-100 unit will flash green, red, green and red.
2. To send the screen down the command is `*1c04;`
3. To send a stop command to the screen is `*1s04;`
4. To send the screen up the command is `*1o04;`
5. The unit will respond with a "LF" if command was good. It will respond with "U" if the command was not understood.

230V Wiring Diagram with Optional SCB-100 Control

NOTE: Electrical connections on left end of case.

Use provided knockouts for all electrical connections. DO NOT drill additional holes into screen case or end cap.

Recommended Wire Size:

Wall Switch: 20-24 AWG

Motor: 14-18 AWG

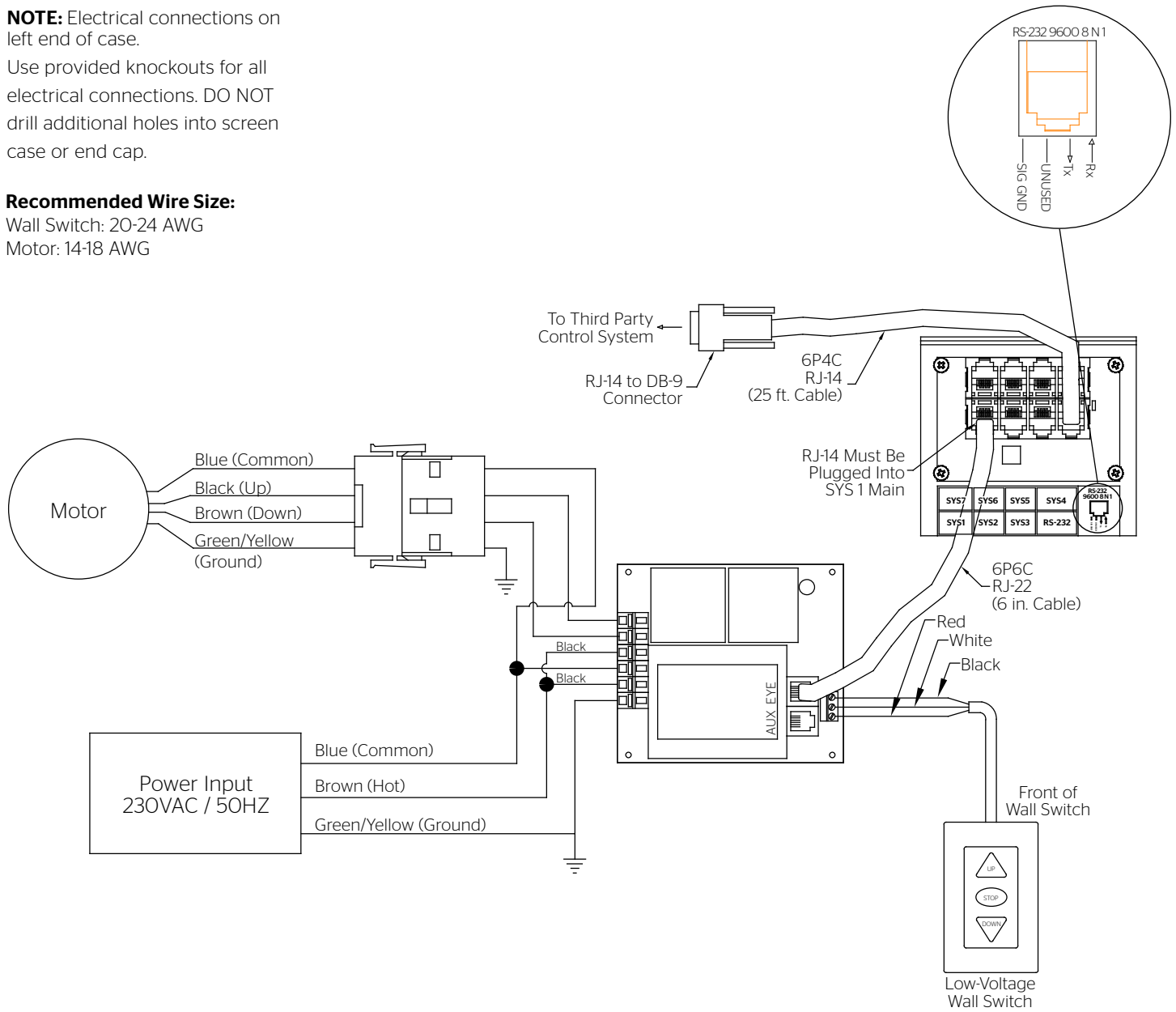

Communication Instructions

The connection settings for the SCB-100 are 9600 Baud Rate, 8 Data Bits, None Parity, 1 stop bit and XON/XOFF Flow Control. The control is NOT Bi-Directional, but it will give a response to commands sent.

1. When the SCB-100 unit first powers on it will send back the (Version, X-on). The LED on the SCB-100 unit will flash green, red, green and red.
2. To send the screen down the command is `"*1c04;"`
3. To send a stop command to the screen is `"*1s04;"`
4. To send the screen up the command is `"*1o04;"`
5. The unit will respond with a "LF" if command was good. It will respond with "U" if the command was not understood.

Troubleshooting

| Symptom | Cause | Solution |
|---|---|--|
| Screen will not operate and motor does not hum. | Incorrect line voltage. | Verify 115-125V (or 220-240V). If insufficient voltage, rewire incoming electric line. |
| | Blown fuse. | Replace fuse. |
| | Tripped circuit breaker. | Reset circuit breaker. |
| | No power to operating switch or junction. | Check above. Tighten all loose wire connections. Correct any improper connections. Down Position Check for power across black and white leads. Up Position Check for power across red and white leads. |
| Screen will not operate and motor does not hum. Power at junction box. | Thermal overload tripped. | Let motor cool down for 15 minutes. Try again. |
| | Broken wire in the "down" or "up" position. | Check for continuity. Cut off old splice and reconnect. |
| | Defective motor, limit switch or capacitor. | Replace motor assembly. NOTE: Motor is a sealed assembly. |
| | Capacitor burned out. | Replace motor assembly. |
| Screen does not stop at correct position. | Limit switch out of adjustment. | See Screen Adjustment section. |
| Noise. NOTE: Screen will operate with a low pitched hum. | Squeaking, rubber end plug rubbing on motor. | Center roller in case. |
| | Grinding. Foreign object in screen rubbing on roller or fabric. | Remove. |
| | Gear noise. | Replace motor assembly. |
| Coasting. | Defective brake. | Replace motor assembly. |
| Fabric hangs crooked. | Screen not installed properly. | Check for level and plumb. |
| | Fabric has backed up inside case. | Adjust "down" limit switch slowly until roller is exposed and wrinkle comes out, then readjust for proper drop. |
| | Fabric is damaged. | Replace fabric. |

Conditions for Transportation and Storage

- Temperature: Between 40 - 100°F (5 - 40°C)
- Relative Humidity: 30% to 70%, non-condensing
- Always keep the projection screen horizontal during transport and storage

Screen surface should be allowed to air out once every two months, or otherwise used on a regular basis, if the temperature is above 72°F (22°C) and at least once every month if the temperature goes above 85°F (30°C).

LIMITED FIVE-YEAR WARRANTY ON DA-LITE PRESENTATION PRODUCTS

Legrand AV Inc. warrants certain Da-Lite branded products to the original purchaser only, to be free from defects in materials and workmanship for a period of five (5) years from the date of purchase by the original purchaser; provided they are properly operated according to Da-Lite's instructions and are not damaged due to improper handling or treatment after shipment from the factory.

Limited five-year warranty applies to the following products:

Wireline Advantage®, Tensioned Advantage Series, Advantage Series, Tensioned DescenderPro, DescenderPro, Tensioned Conference, Tensioned Professional, Professional, Da-Lift Projector Lifts, Tensioned Contour®, Contour, Tensioned Cosmopolitan® Series, Cosmopolitan Series, Designer Contour, Slimline, Studio, Arena, Motorized Scenic Roller, Ascender, Parallax®, Parallax Thin, FullVision, UTB Contour, Cinema Contour, Da-Snap, Perm-Wall, Imager, IDEA™ Screen, IDEA Panoramic, Fast-Fold® Deluxe, Fast-Fold Deluxe Drapery Kits, Flex Plex, Da-Glas, Da-Plex Rear Projection Mirror System, and Holo Screen.

This warranty does not apply to equipment showing evidence of misuse, abuse or accidental damage, or which has been tampered with or repaired by a person other than authorized Da-Lite personnel.

Da-Lite's sole obligation under this warranty shall be to repair or to replace (at Da-Lite's option) the defective part of the merchandise. Returns for service should be made to your Da-Lite dealer. If it is necessary for the dealer to return the screen or part to Da-Lite, transportation expenses to and from Da-Lite are payable by the purchaser and Da-Lite is not responsible for damage in shipment. To protect yourself against damage or loss in transit, insure the product and prepay all transportation expenses.

TO THE MAXIMUM EXTENT PERMITTED BY APPLICABLE LAW, THIS WARRANTY IS IN LIEU OF ALL OTHER WARRANTIES, EXPRESS OR IMPLIED, INCLUDING WARRANTIES AS TO FITNESS FOR USE AND MERCHANTABILITY. Any implied warranties of fitness for use, or merchantability, that may be mandated by statute or rule of law are limited to the five (5) year warranty period. This warranty gives you specific legal rights, and you may also have other rights, which vary from state-to-state. **TO THE MAXIMUM EXTENT PERMITTED BY APPLICABLE LAW, NO LIABILITY IS ASSUMED FOR EXPENSES OR DAMAGES RESULTING FROM INTERRUPTION IN OPERATION OF EQUIPMENT, OR FOR INCIDENTAL, DIRECT, OR CONSEQUENTIAL DAMAGES OF ANY NATURE.**

In the event that there is a defect in materials or workmanship of a Da-Lite product, you may contact Customer Care at 3100 North Detroit Street, Warsaw, IN 46582, (866) 977-3901.

IMPORTANT: THIS WARRANTY SHALL NOT BE VALID AND DA-LITE BRANDED PRODUCTS SHALL NOT BE BOUND BY THIS WARRANTY IF THE PRODUCT IS NOT OPERATED IN ACCORDANCE WITH THE DA-LITE WRITTEN INSTRUCTIONS.

Keep your sales receipt to prove the date of purchase and your original ownership.



FOR YOUR IMAGE | legrandav.com

| | | |
|--------|-------------------|--|
| USA | P 866.977.3901 | E av.da-lite.support@legrand.com |
| CANADA | P 877.345.4329 | E av.da-lite.support@legrand.com |
| EMEA | P +31 495 580 840 | E av.emea.sales@legrand.com |
| APAC | P +852 2145 4099 | E av.asia.sales@legrand.com |

© 2020 Legrand AV Inc. 200074 (Rev. 5) 3/20 Da-Lite is a registered trademark of Legrand AV Inc. All other brand names or marks are used for identification purposes and are trademarks of their respective owners. All patents are protected under existing designations. Other patents pending.



COMMERCIAL BRANDS

Chief | Da-Lite | Middle Atlantic | Projecta | Vaddio

35890



INSTRUCTION MANUAL

Tensioned Advantage®
(Featuring ViewShare Technology)



Original Instructions

Disclaimer

Legrand AV Inc. and its affiliated companies and subsidiaries (collectively, "Legrand AV"), intend to make this manual accurate and complete. However, Legrand AV makes no claim that the information contained herein covers all details, conditions or variations, nor does it provide for every possible contingency in connection with the installation or use of the products described herein. The content herein is subject to change without notice or obligation of any kind. To the maximum extent permitted by applicable law, Legrand AV makes no representation or warranty, expressed or implied, regarding the information contained herein. Furthermore, Legrand AV assumes no responsibility for accuracy, completeness or sufficiency of the information contained in this document.

Da-Lite® is a registered trademark of Legrand AV. All rights reserved.

Important Safety Instructions

When using your video equipment, basic safety precautions should always be followed, including the following:

1. Read and understand all instructions before using.
2. Position the cord so that it will not be tripped over, pulled, or contact hot surfaces.
3. If an extension cord is necessary, a cord with a current rating at least equal to that of the appliance should be used. Cords rated for less amperage than the appliance may overheat.
4. To reduce the risk of electric shock, do not disassemble this appliance. Contact an authorized service dealer when repair work is required. Incorrect reassembly can cause electric shock when the appliance is used subsequently.
5. The use of an accessory attachment not recommended by the manufacturer may cause a risk of fire, electric shock, or injury to persons.
6. Failure to provide adequate structural strength for this component can result in serious personal injury or damage to equipment! It is the installer's responsibility to make sure the structure to which this component is attached can support the weight of all equipment. Reinforce the structure as required before installing the component.
7. Use this projection screen only for its intended use as described in these instructions. Do not use attachments not recommended by the manufacturer.

Save These Instructions

Tools Required for Installation

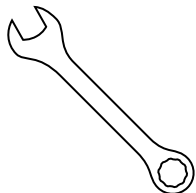

1/2" Open Wrench
or Socket Driver

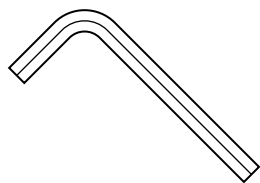

1/8" Hex Key
(included)

Pre-Installation

1. Carefully unpack case from shipping carton.
2. Set aside the Installation Kit. Items inside will be used during installation.
3. Make sure to recheck measurement of case for proper installation clearance.
4. Remove any protective foam covering the outside of the case.
5. For shipping purposes, foam is also inserted between the roller brackets and endcaps. Remove these foam blocks from the ends.
6. Remove the hanger brackets from the top of the case using a 1/2" wrench. Do not discard the hardware; it will be used during case installation to re-attach the hanger brackets for mounting.

Case Installation

1. Hang case and attach to support structure with bolts. See Suggested Methods of Installation.
2. Tighten bolts until trim flange is flush with ceiling.
NOTE: For proper operation, screen assembly must be level after installation.
3. Remove 2 screws to open junction box. Install electrical connections that apply to your unit. Make sure to review the wiring diagram for proper hook up. Replace junction box cover and secure with 2 screws.

NOTE: Must be installed in accordance with the requirements of the Local Building Codes, the Canadian Electrical Code (CEC), CAN/CSA C22.1 and the National Electric Code (NEC), NFPA 70.

If your case was ordered in advance of the screen and roller assembly, your installation is now complete. Continue to step 4 if your Tensioned Advantage Electrol was ordered as a complete unit.

4. Use supplied 1/8" hex key to remove silver shipping brackets attached to slat and screen case.
5. Test installation by running screen up and down a few times. Be prepared to stop screen should any objects obstruct the movement of the screen. To prevent damage to the motor, the standard duty cycle is 1 minute on and 3 minutes off.

Suggested Methods of Installation

Method 1

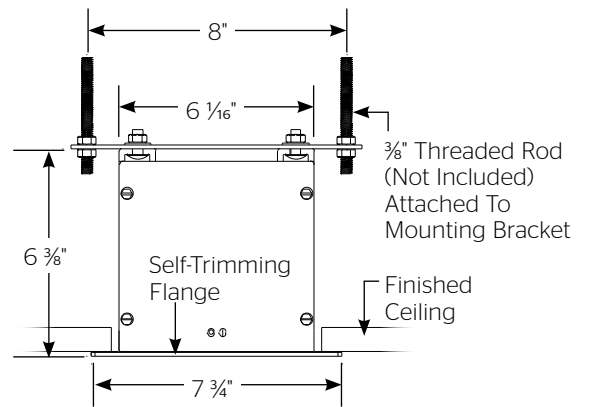
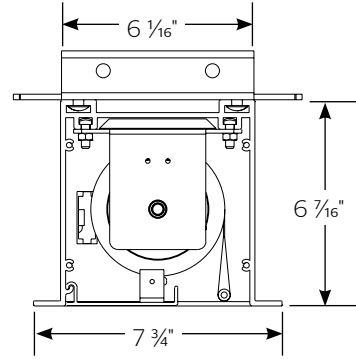
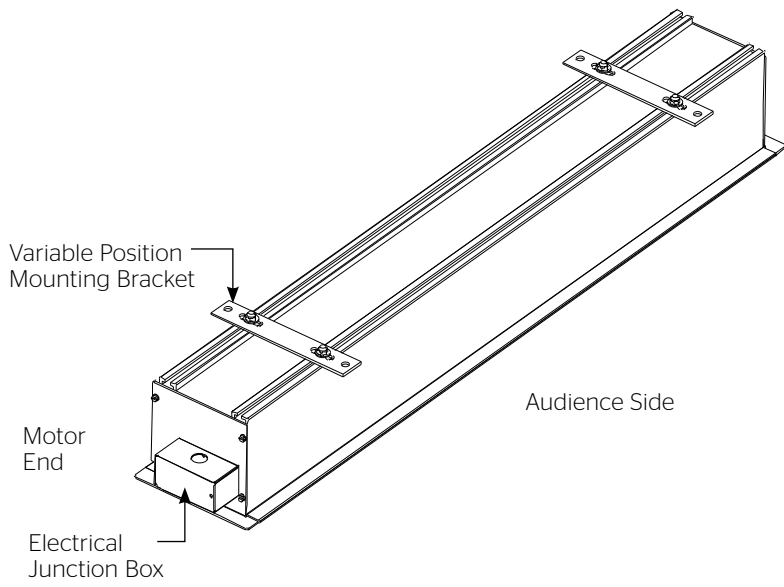

Method 2

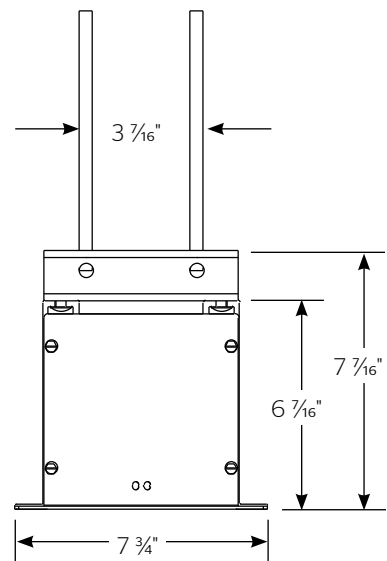
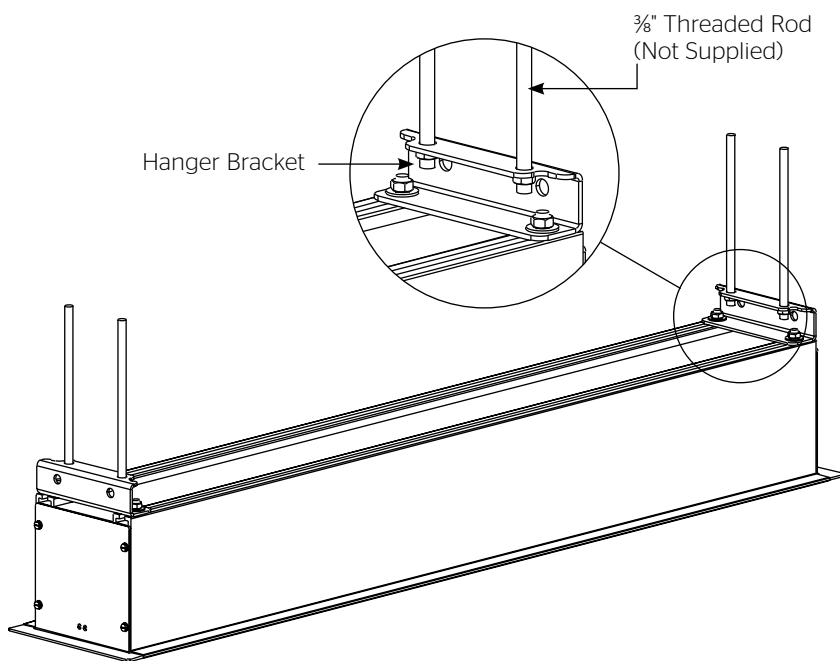

Wall Switch Installation for 120V Screens

120V Wiring Diagram

3-conductor 20-24 gauge wire can be used in place of the supplied RJ-14 cable to connect the wall switch. Connect the BUS terminals on the wall switch to the corresponding BUS terminals on the splitter board.

IMPORTANT NOTE: The wall switch is REQUIRED to make any limit switch adjustments, EVEN if a third party control system is used. Therefore, it is advised to wire the switch or provide a 3-conductor connection that is accessible.

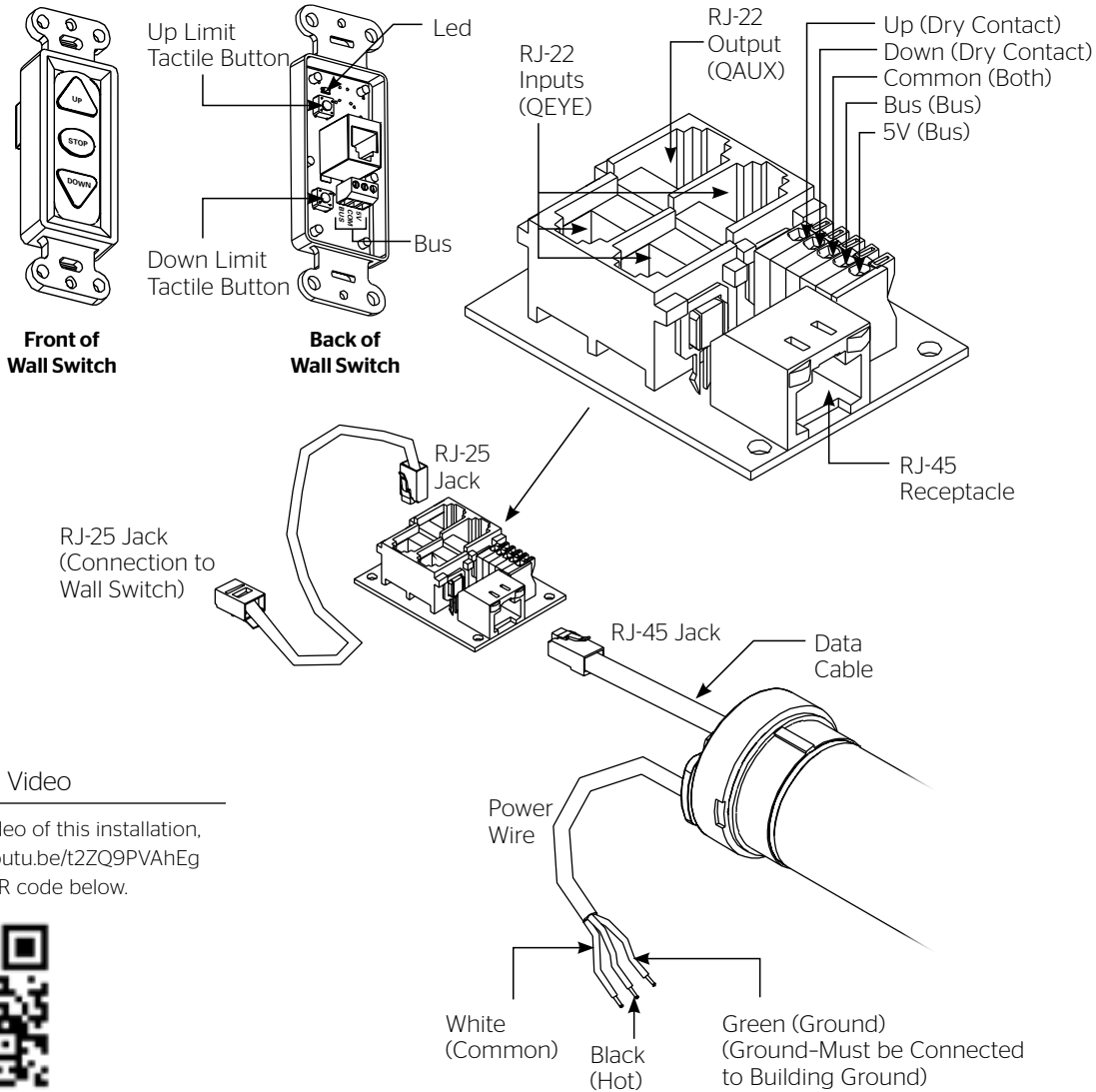

Installation Video

To view a video of this installation, visit <http://youtu.be/t2ZQ9PVAhEg> or use the QR code below.



Power Input 120VAC / 60Hz

RJ-14 Pin-Outs (Tab Is Facing Down)



Supplied RJ-14 cable

RJ-25 Pin-Outs (Tab Is Facing Down)

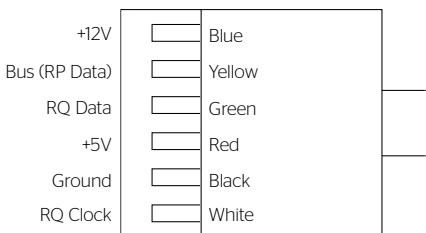

Standard RJ-25 can be used in place of RJ-14 cable

RJ-45 Pin-Outs (Tab Is Facing Down)

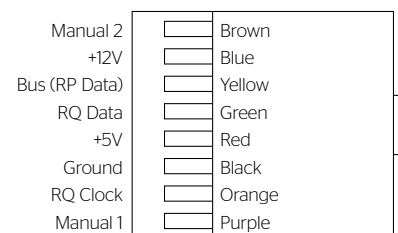

Video Projector Interface Installation for 120V Screens (Optional)

120V Wiring Diagram with Optional Built-In Video Projector Interface

CAUTION: The projector must be turned off before connecting the trigger wires to the projector. Failure to do so may damage the controller.

ATTENTION: Le projecteur doit être éteint avant de brancher les fils de déclenchement à celui-ci. Tout manquement à cette instruction pourrait endommager le contrôleur.

Use 2-conductor 20-24 gauge wire to extend the low voltage connection from the projector's 5 or 12-volt screen trigger output to the length required to reach the VPI. When extending the low voltage connection from the projector's screen trigger output polarity does not matter. The red and black wires from the VPI are interchangeable.

IMPORTANT NOTE: The wall switch is REQUIRED to make any limit switch adjustments, EVEN if a third party control system is used. Therefore, it is advised to wire the switch or provide a 3-conductor connection that is accessible.

3-conductor 20-24 gauge wire can be used in place of the supplied RJ-14 cable to connect the wall switch. Connect the BUS terminals on the wall switch to the corresponding BUS terminals on the splitter board.

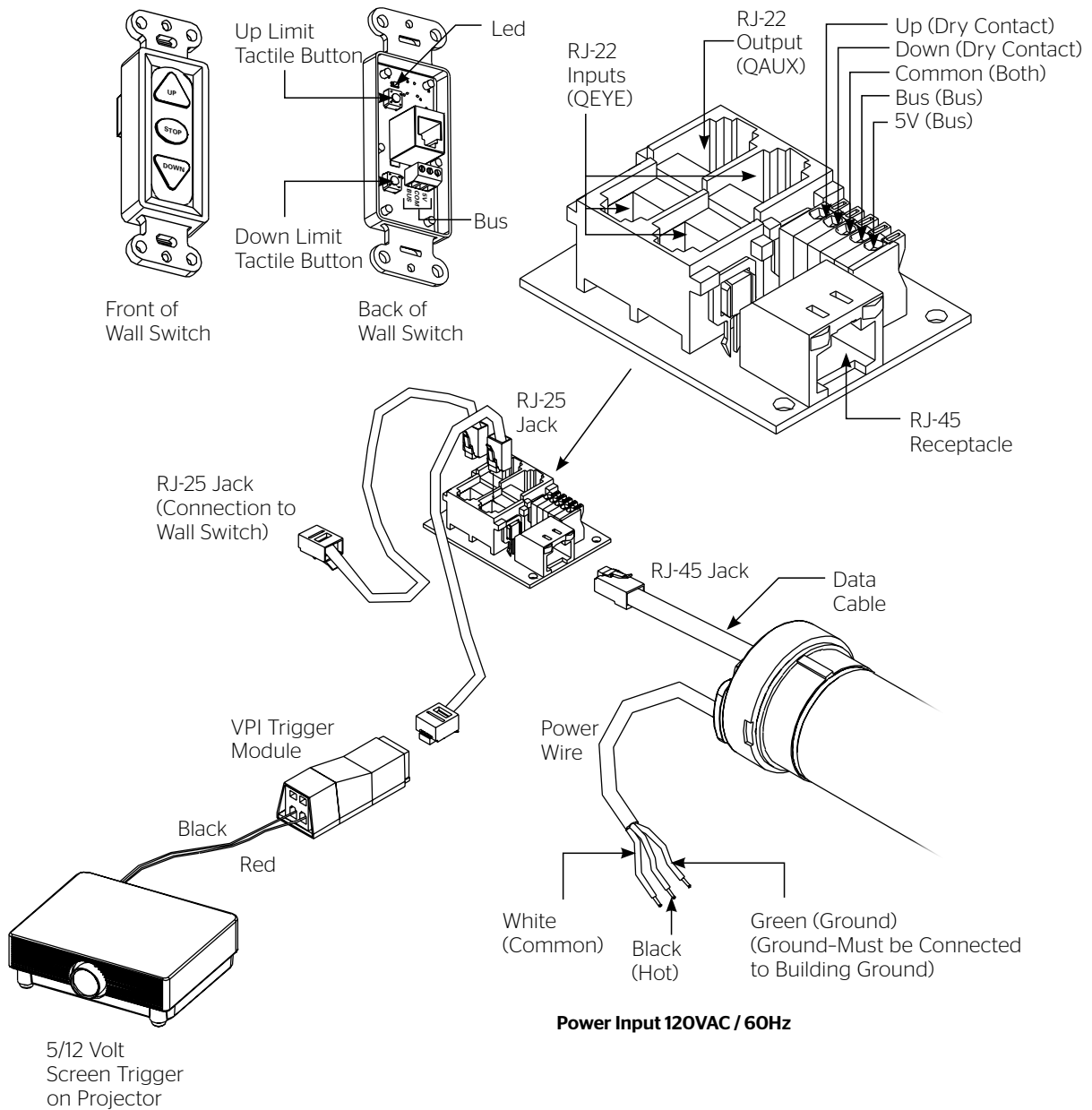

Low Voltage Connections for 120V Screens

Control Panel

A control panel may be connected to the splitter board by using the dry contact Up, Down and Common connections (see page 6). The control panel must provide a momentary, dry contact closure of at least 1/2 second.

1. Use 3-conductor 20-24 gauge wire to connect the control panel to the splitter board.
2. A momentary closure across the common and up wires will be an “up” command.
3. A momentary closure across the common and down wires will be a “down” command.
4. A momentary closure across the common, up and down wires will be a “stop” command.

Screen Adjustment for 120V Screens

If your Tensioned Advantage (Featuring ViewShare Technology) was ordered as a complete unit, the up and down limits were pre-set by Da-Lite. If your screen and roller assembly was ordered separately from the case, or if general adjustment is needed, please follow the steps below and refer to the 120V Wiring Diagram.

1. Locate the wall switch and remove the cover plate from the wall switch and remove the switch from the junction box.
2. Locate the two tactile buttons on the back of the switch. They are black round buttons on silver plates. See 120V Wiring Diagram.
3. To adjust the down limit switch, press and hold the down tactile button until the LED on the back of the switch turns solid red. This will put the motor in limit set mode. Turn the wall switch over and use the down button on the front of the switch. Press and hold the down button until the desired down position is reached. If you travel too far down, press the up button to move the screen upward. If you press and let go of either the up or down buttons, the motor will do a small jog in that direction for fine adjustment of the screen. Once the desired position is reached, turn the switch over; press and hold the down tactile button until the LED on back of switch blinks red twice. The down limit is now set.

⚠ CAUTION: Do not adjust for more drop than what was ordered. At least 1-1/2 wraps of fabric must remain on the roller. This screen comes standard with 12" black at the top.

⚠ ATTENTION! N'effectuez pas de réglage pour obtenir un déroulement supérieur à celui commandé. Au moins 1 à 1/2 tour de toile doit être maintenu sur le cylindre. Ce écran est doté de série d'une bande noire supérieure de 30,5 cm (12 po).

NOTE: If the screen is in limit set mode and no buttons are pushed for 20 seconds, the LED on the back of the wall switch

will turn off, the motor will return to run mode and no changes will be saved. If this occurs, return to step 3 for down limit adjustment or step 4 for up limit adjustment.

4. To adjust the up limit switch, press and hold the up tactile button until the LED on the back of the switch turns solid green. This will put the motor in limit set mode. Turn the wall switch over and use the up button on the front of the switch. Press and hold the up button until the desired up position is reached. If you travel too far up, press the down button to move the screen downward. If you press and let go of either the up or down buttons, the motor will do a small jog in that direction for fine adjustment of the screen. Once the desired position is reached, turn the switch over; press and hold the up tactile button until the LED on back of switch blinks green twice. The up limit is now set.

⚠ CAUTION: Adjusting the down limit switch by more than 6" can cause the screen surface to lose proper tensioning.

⚠ ATTENTION! Le fait d'ajouter plus de 15 cm (6po) aux interrupteurs de fin de course peut faire perdre la bonne tension à la surface de l'écran.

5. To test the limit switch settings, press and release the up or down buttons on the switch to operate the screen.
6. Replace the switch and cover plate on the wall.

IMPORTANT NOTE: The wall switch is REQUIRED to make any limit switch adjustments, even if a third party control system is used. Therefore, it is advised to wire the switch or provide a 3-conductor connection that is accessible.

Wall Switch Installation for 220/240V Screens

240V Wiring Diagram

IMPORTANT NOTE: The wall switch is REQUIRED to make any limit switch adjustments, EVEN if a third party control system is used. Therefore, it is advised to wire the switch or provide a 4-conductor connection that is accessible.

ILT RJ-9 Pin-Outs (Tab Is Facing Down)

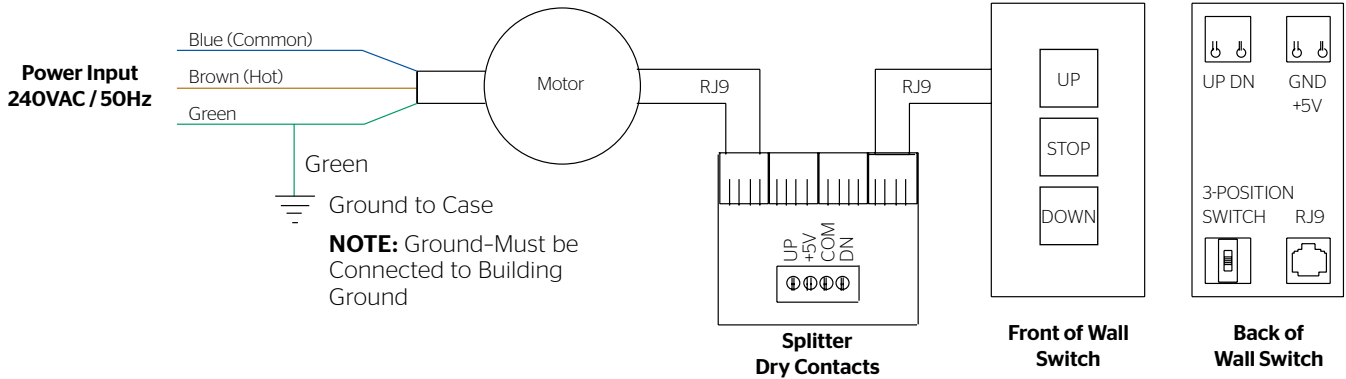

240V Wiring Diagram with Optional Built-in Video Projector Interface

CAUTION: The projector must be turned off before connecting the trigger wires to the projector. Failure to do so may damage the controller.

ATTENTION: Le projecteur doit être éteint avant de brancher les fils de déclenchement à celui-ci. Tout manquement à cette instruction pourrait endommager le contrôleur.

1. Use 2-conductor 20-24 gauge wire to extend the low voltage connection from the projector's 5 or 12-volt screen trigger output to the length required to reach the VPI. When extending the low voltage connection from the projector's screen trigger output, be

sure to maintain the proper polarity. The red wire from the VPI is the "signal" and the black wire from the VPI is the "ground".

2. Connect the wires from the VPI that are labeled "Low Voltage Connection" to the end of the extended screen trigger wires above.

IMPORTANT NOTE: The wall switch is REQUIRED to make any limit switch adjustments, EVEN if a third party control system is used. Therefore, it is advised to wire the switch or provide a 4-conductor connection that is accessible.

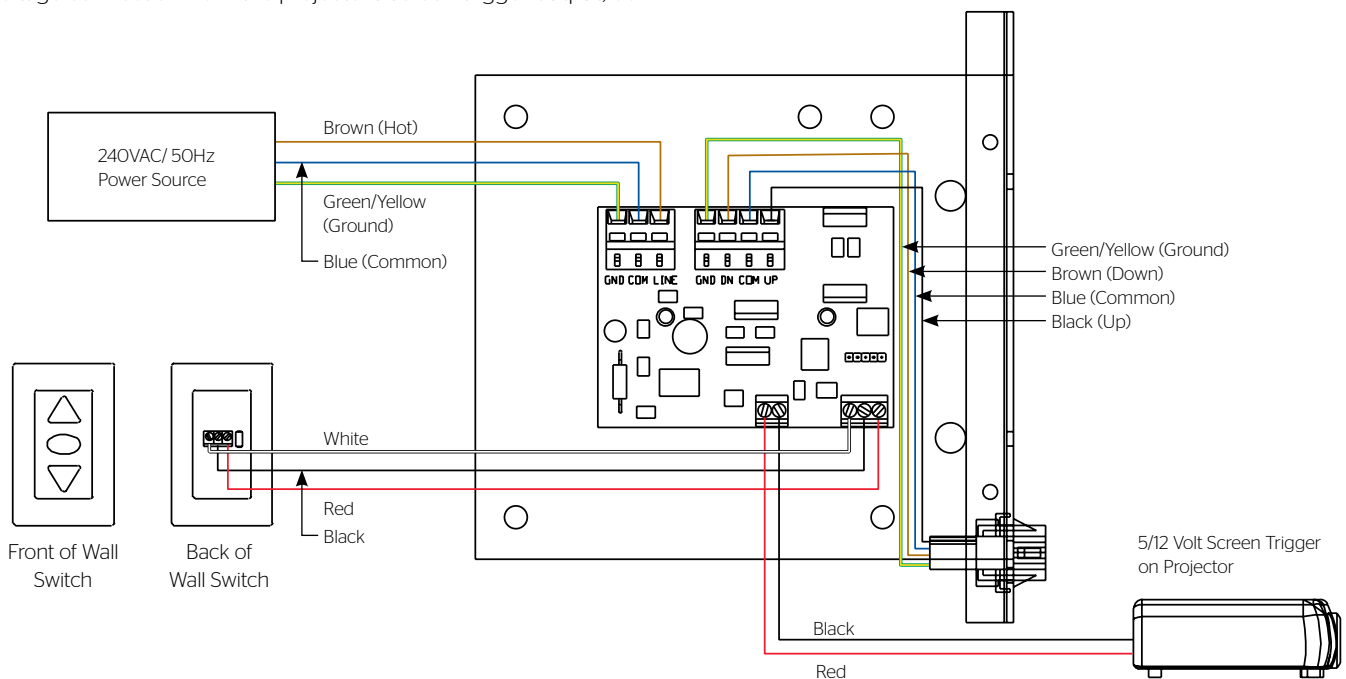

Low Voltage Connections for 220V/240V Screens

Control Panel

A control panel may be connected to the integrated LVC by using the wall switch wire lead. The control panel must provide a momentary, dry contact closure of at least 1/2 second.

1. Use 3-conductor 20-24 gauge wire to connect the control panel to the wall switch lead.
2. A momentary closure across the white and red wires will be an “up” command.
3. A momentary closure across the white and black wires will be a “down” command.
4. A momentary closure across the white, red and black wires will be a “stop” command.

Screen Adjustment for 220V/240V Screens

1. Remove the cover plate from the 3-button wall switch and remove the switch from the junction box.
2. Locate small 3-position switch on back of wall switch. See Figure 5 for 120V screens or Figure 8 for 220/240V screens.
3. To adjust the down limit switch, slide the 3-position switch to the down position. Press and hold the down button to run the screen down to the desired stop position. Release the button to stop the screen. DO NOT PUSH THE STOP BUTTON.

⚠ CAUTION: Do not adjust for more drop than what was ordered. At least 1-1/2 wraps of fabric must remain on the roller. This screen comes standard with 12" black at the top. See the specification data sheet for details.

⚠ ATTENTION! N'effectuez pas de réglage pour obtenir un déroulement supérieur à celui commandé. Au moins 1 à 1/2 tour de toile doit être maintenu sur le cylindre. Ce écran est doté de série d'une bande noire supérieure de 30,5 cm (12 po).

4. When the screen is in the desired down position, slide the 3-position switch to the off (center) position. The down limit switch is now set.
5. To adjust the up limit switch, slide the 3-position switch to the up position. Press and hold the up button to run the screen up to

the desired stop position. Release the button to stop the screen. DO NOT PUSH THE STOP BUTTON.

⚠ CAUTION: Adjusting the down limit switch by more than 6" can cause the screen surface to lose proper tensioning.

⚠ ATTENTION! Le fait d'ajouter plus de 15 cm (6po) aux interrupteurs de fin de course peut faire perdre la bonne tension à la surface de l'écran.

6. When the screen is in the desired up position, slide the 3-position switch to the off (center) position. The up limit switch is now set.
7. To test limit switch setting, make sure the 3-position switch is in the off (center) position. Press and release the up or down button on the wall switch to operate the screen.
8. Replace switch and cover plate on the wall.

NOTE: If stop button is pressed, the wall switch will reverse direction. To correct this, press the stop button again. This will reset the switch. You will have to re-set both the up and the down limit settings.

IMPORTANT NOTE: The wall switch is REQUIRED to make any limit switch adjustments, EVEN if a third party control system is used. Therefore, it is advised to wire the switch or provide a 4-conductor connection that is accessible.

Camera and Speakerphone Installation

The following components are necessary for camera and speakerphone installation.

Included:

- Local CAT5 to USB Extender with Power Supply
- 6' USB Cable
- USB Speakerphone
- Powered USB Hub

You also will need enough CAT5 or CAT5e network cable to run from the Tensioned Advantage (Featuring ViewShare Technology) to the Local CAT5 to USB Extender. THE CAT5 CABLE IS NOT PROVIDED. The length of the CAT5 cable cannot exceed 200 feet.

For computer system requirements, specifications and troubleshooting, see the separate camera instruction located in the Installation Kit and the Speakerphone instruction located inside the Speakerphone box. Additionally, links to online assistance for each device are located in the Troubleshooting section of this instruction book.

Connections (see wiring diagram below)

1. Plug your CAT5 cable into connection port located on the left end of the Tensioned Advantage (Featuring ViewShare Technology) (Figure 1).
2. Connect your CAT5 cable to the Local CAT5 to USB Extender, which should be located near your computer. Connect the Local CAT5 to USB Extender power supply at this time.

NOTE: The CAT5 cable should only be connected between the Tensioned Advantage (Featuring ViewShare Technology) and the Local CAT5 to USB Extender. Do not connect to a server or network.

3. Lower the Tensioned Advantage (Featuring ViewShare Technology) screen and note the camera location in the center of the slat bar (Figure 2).
4. Use the 6' USB Cable to connect the Local CAT5 to USB Extender to the USB Hub.
5. Connect the Speakerphone to the Powered USB Hub.
6. Connect the USB Hub to your computer. Connect the USB Hub power supply at this time.

NOTE: The computer may recognize the USB Hub as a new component but It does not require any additional drivers. The USB Hub does not need to be used if your computer has two open USB ports.

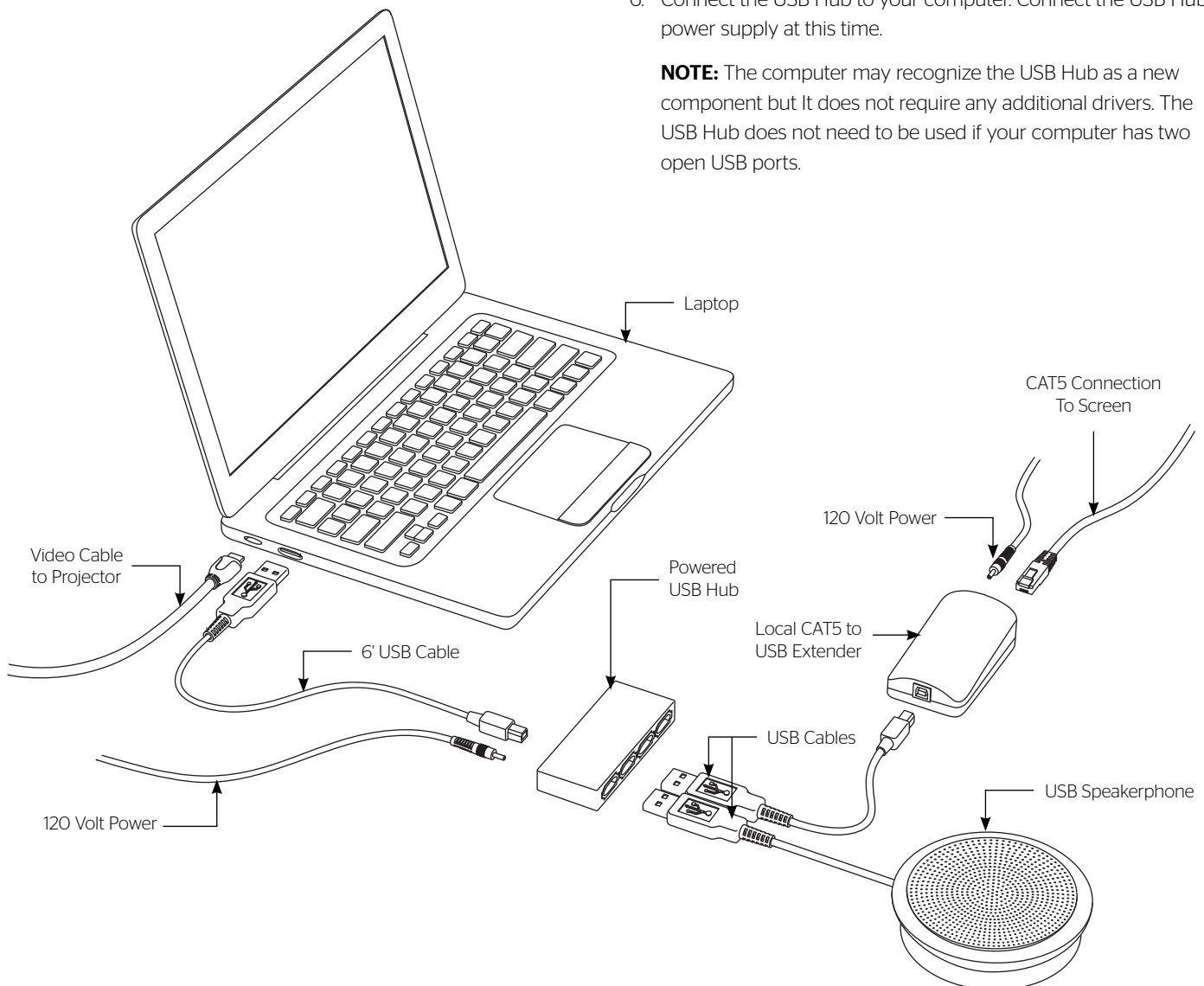

Camera and Speakerphone Setup

You are now ready to run the initial camera setup. The computer will recognize the camera as a new component and load the appropriate drivers. This can take up to several minutes and you may need to follow on-screen instructions. If the computer is using Windows 7 or later version, the computer will automatically detect the camera, choose the proper drivers, and install the drivers without your input. Once the green LED on the Local CAT5 to USB Extender is illuminated and the drivers are installed, you are ready to use the camera.

If the LED does not turn green after install, your computer may need to be restarted before the camera can be used. This could be a result of the type of operating system and other hardware/software installed, and is not necessarily a faulty device.

1. Open Lync, Skype or other compatible video calling software.
2. Go to the options menu and select "C930e" under the video devices.

NOTE: The Da-Lite bowtie around the camera will glow when the camera is selected. If the window says "No camera detected", go back to the Connections section and check each step.

3. In your software's options menu, select "Speakerphone 410" under the audio devices.

Installation is now complete and you are now ready to use your compatible video calling software.

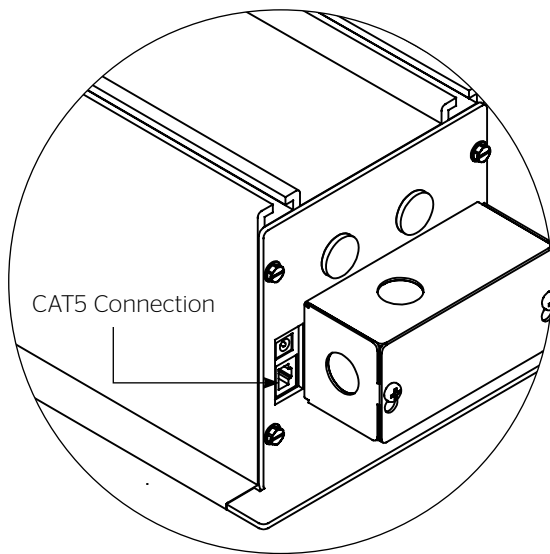

Figure 1

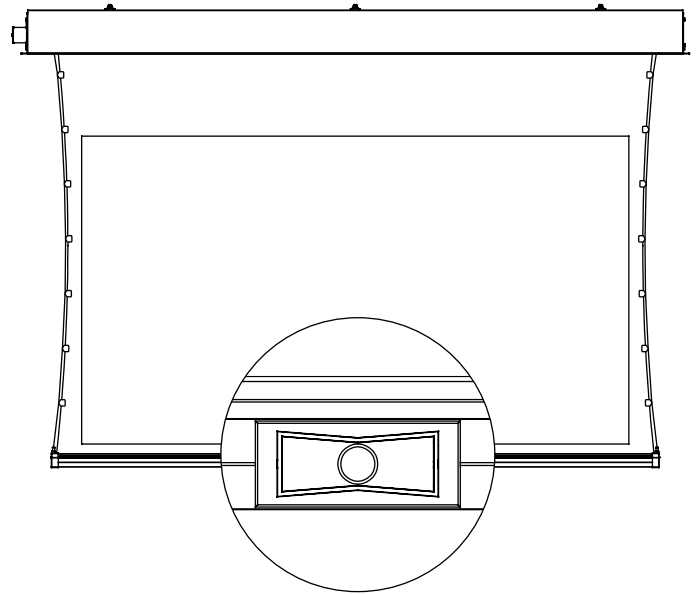

Figure 2

Troubleshooting

| Symptom | Cause | Solution |
|---|---|--|
| Screen will not operate and motor does not hum. | Incorrect line voltage. | Verify 115-125V (or 220-240V). If insufficient voltage, rewire incoming electric line. |
| | Blown fuse. | Replace fuse. |
| | Tripped circuit breaker. | Reset circuit breaker. |
| | No power to operating switch or junction. | Check above. Tighten all loose wire connections. Correct any improper connections. Down Position Check for power across black and white leads. Up Position Check for power across red and white leads. |
| Screen will not operate and motor does not hum. Power at junction box. | Thermal overload tripped. | Let motor cool down for 15 minutes. Try again. |
| | Broken wire in the "down" or "up" position. | Check for continuity. Cut off old splice and reconnect. |
| | Defective motor, limit switch or capacitor. | Replace motor assembly. NOTE: Motor is a sealed assembly. |
| | Capacitor burned out. | Replace motor assembly. |
| Screen does not stop at correct position. | Limit switch out of adjustment. | See Screen Adjustment section. |
| Noise. NOTE: Screen will operate with a low pitched hum. | Squeaking, rubber end plug rubbing on motor. | Center roller in case. |
| | Grinding. Foreign object in screen rubbing on roller or fabric. | Remove. |
| | Gear noise. | Replace motor assembly. |
| Coasting. | Defective brake. | Replace motor assembly. |
| Fabric hangs crooked. | Screen not installed properly. | Check for level and plumb. |
| | Fabric has backed up inside case. | Adjust "down" limit switch slowly until roller is exposed and wrinkle comes out, then readjust for proper drop. |
| | Fabric is damaged. | Replace fabric. |

Camera Support: <http://www.logitech.com/en-us/support/webcam-c930e-business?crd=405&osid=14&bit=64>

Speakerphone Support: http://www.jabra.com/support/Jabra-SPEAK-410-MS_7410-109

Conditions for Transportation and Storage

- Temperature: Between 40 - 100°F (5 - 40°C)
- Relative Humidity: 30% to 70%, non-condensing
- Always keep the projection screen horizontal during transport and storage
- Make sure the entire package is supported when stored
- Do not stack more than six projection screens on top of each other
- Make sure the heaviest package is placed at the bottom of the stack

Screen surface should be allowed to air out once every two months, or otherwise used on a regular basis, if the temperature is above 72°F (22°C) and at least once every month if the temperature goes above 85°F (30°C).

LIMITED FIVE-YEAR WARRANTY ON DA-LITE PRESENTATION PRODUCTS

Legrand AV Inc. warrants certain Da-Lite branded products to the original purchaser only, to be free from defects in materials and workmanship for a period of five (5) years from the date of purchase by the original purchaser; provided they are properly operated according to Da-Lite's instructions and are not damaged due to improper handling or treatment after shipment from the factory.

Limited five-year warranty applies to the following products:

Wireline Advantage®, Tensioned Advantage Series, Advantage Series, Tensioned DescenderPro, DescenderPro, Tensioned Conference, Tensioned Professional, Professional, Da-Lift Projector Lifts, Tensioned Contour®, Contour, Tensioned Cosmopolitan® Series, Cosmopolitan Series, Designer Contour, Slimline, Studio, Arena, Motorized Scenic Roller, Ascender, Parallax®, Parallax Thin, FullVision, UTB Contour, Cinema Contour, Da-Snap, Perm-Wall, Imager, IDEA™ Screen, IDEA Panoramic, Fast-Fold® Deluxe, Fast-Fold Deluxe Drapery Kits, Flex Plex, Da-Glas, Da-Plex Rear Projection Mirror System, and Holo Screen.

This warranty does not apply to equipment showing evidence of misuse, abuse or accidental damage, or which has been tampered with or repaired by a person other than authorized Da-Lite personnel.

Da-Lite's sole obligation under this warranty shall be to repair or to replace (at Da-Lite's option) the defective part of the merchandise. Returns for service should be made to your Da-Lite dealer. If it is necessary for the dealer to return the screen or part to Da-Lite, transportation expenses to and from Da-Lite are payable by the purchaser and Da-Lite is not responsible for damage in shipment. To protect yourself against damage or loss in transit, insure the product and prepay all transportation expenses.

TO THE MAXIMUM EXTENT PERMITTED BY APPLICABLE LAW, THIS WARRANTY IS IN LIEU OF ALL OTHER WARRANTIES, EXPRESS OR IMPLIED, INCLUDING WARRANTIES AS TO FITNESS FOR USE AND MERCHANTABILITY. Any implied warranties of fitness for use, or merchantability, that may be mandated by statute or rule of law are limited to the five (5) year warranty period. This warranty gives you specific legal rights, and you may also have other rights, which vary from state-to-state. **TO THE MAXIMUM EXTENT PERMITTED BY APPLICABLE LAW, NO LIABILITY IS ASSUMED FOR EXPENSES OR DAMAGES RESULTING FROM INTERRUPTION IN OPERATION OF EQUIPMENT, OR FOR INCIDENTAL, DIRECT, OR CONSEQUENTIAL DAMAGES OF ANY NATURE.**

In the event that there is a defect in materials or workmanship of a Da-Lite product, you may contact Customer Care at 3100 North Detroit Street, Warsaw, IN 46582, (866) 977-3901.

IMPORTANT: THIS WARRANTY SHALL NOT BE VALID AND DA-LITE BRANDED PRODUCTS SHALL NOT BE BOUND BY THIS WARRANTY IF THE PRODUCT IS NOT OPERATED IN ACCORDANCE WITH THE DA-LITE WRITTEN INSTRUCTIONS.

Keep your sales receipt to prove the date of purchase and your original ownership.



FOR YOUR IMAGE | legrandav.com

USA P 866.977.3901 E av.da-lite.support@legrand.com
CANADA P 877.345.4329 E av.da-lite.support@legrand.com
EMEA P +31 495 580 840 E av.emea.sales@legrand.com
APAC P +852 2145 4099 E av.asia.sales@legrand.com

© 2020 Legrand AV Inc. 200075 (Rev. 4) 3/20 Da-Lite is a registered trademark of Legrand AV Inc. All other brand names or marks are used for identification purposes and are trademarks of their respective owners. All patents are protected under existing designations. Other patents pending.



COMMERCIAL BRANDS

Chief | Da-Lite | Middle Atlantic | Projecta | Vaddio

24954



FOR YOUR IMAGE | legrandav.com

| | | |
|---------------|--------------------------|---|
| USA | P 866.977.3901 | E av.da-lite.support@legrand.com |
| CANADA | P 877.345.4329 | E av.da-lite.support@legrand.com |
| EMEA | P +31 495 580 840 | E av.emea.sales@legrand.com |
| APAC | P +852 2145 4099 | E av.asia.sales@legrand.com |

© 2020 Legrand AV Inc. 200076 3/20 Da-Lite is a registered trademark of Legrand AV Inc. All other brand names or marks are used for identification purposes and are trademarks of their respective owners. All patents are protected under existing designations. Other patents pending.



COMMERCIAL BRANDS

Chief | Da-Lite | Middle Atlantic | Projecta | Vaddio