

| MODEL # | | VZ-27CMP |
|----------------------------------|--|----------|
| VIDEO | | |
| Screen Size | 27" | |
| Max. Resolution | 1920 x 1080 @60Hz | |
| Pixel Pitch | 0.3114 mm x 0.3114 mm | |
| Brightness | 250cd/m ² (Typical) | |
| Contrast Ratio | 1000:1 | |
| Aspect Ratio | 16 : 9 | |
| Viewing Angle (H/V) | 178° / 178° | |
| Display Color | 16.7 Million | |
| Response Time | < 8 ms | |
| Video System | NTSC / PAL | |
| INTERFACE | | |
| CVBS (BNC) In / Out | 1 / 1 | |
| VGA In (15Pin D-Sub) | 1 | |
| HDMI In | 1 | |
| Audio In | 1 | |
| AUDIO | | |
| Built in speaker | 2W X 2 | |
| SPECIAL FEATURES | | |
| Filter Type | 3D Comb-filter / De-Interlace | |
| Language | English, Deutsch, French, Spanish, Italian | |
| DIMENSIONS & WEIGHT | | |
| Outline Dimension (W x H x D) | 24.17" x 18" x 1.69" | |
| | 541.4 mm x 457.26 mm x 43.0 mm | |
| Net Weight / Gross Weight | 8.92 lbs (4.05kg) / 12.34 lbs (5.6kg) | |
| MOUNT | | |
| VESA | 100mm x 100mm (M4 x L8 screws) | |
| GENERAL | | |
| Power | Electrical Ratings DC 12V, 3A (AC 100-240V, 50/60Hz) Consumption 30 W | |
| Operating Temperature Humidity | 14 ~ 122°F / -10 ~ 50°C 5 ~ 90% RH | |
| Regulations | FCC(A), CE, RoHS | |
| Compatible Mounts | WALL CEILING VZ-WM50, VZ-AM02-A VZ-CMKIT-01, VZ-CM308 | |

VZ-27CMP ADVANTAGES

- 27" Full HD Resolution
- 3D Comb-filter, De-Interlace
- 16:9 / 4:3 Ratio Available, HDMI, VGA, PC Audio, AV Audio
- 1 CVBS (BNC) Input / Output (Loop-through)
- Built-in Speakers, Auto Source & Power Recovery
- Built to run 24/7/365
- 3-Year Warranty

DIMENSIONS

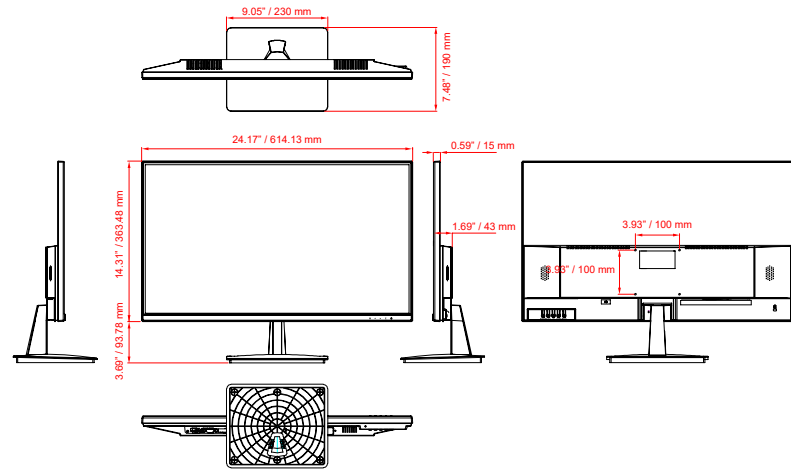

INTERFACE

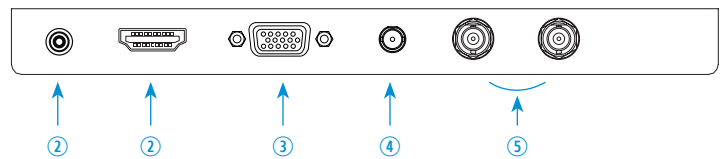

1. DC12V IN
2. HDMI IN
3. VGA IN
4. Audio IN
5. CVBS (BNC) IN / OUT

Contact ViewZ

- Address : 177 W. Orangethorpe Ave., Placentia, CA 92870
- Phone : (714) 996-1177, Fax : (714) 996-1138
- Sales : sales@viewzusa.com
- Specification subject to change without notice.