

# MOUNTS AND ACCESSORIES FOR 30 SERIES CAMERAS

Honeywell's 30 Series mounts and accessories provide a wide range of installation options for the Honeywell 30 Series IP cameras, including junction box, mounting adapter, pendant pipe, wall mount bracket, pole mount adapter, corner mount adapter, etc.

The mounts provide easy cable routing with no exposed wiring, and the cameras can be installed, adjusted, and tested without repositioning the housing. All of the mounts and accessories are suitable for indoor or outdoor use.

The junction box, pendant mounting cap, pendant mounting pipe, wall mounting bracket and pole mounting adapter are constructed of die-casting aluminum. The corner mounting adapter is made of SECC steel. All of the mounts and accessories are powder coated to match the finish of the camera.

## MARKET OPPORTUNITIES

Honeywell's 30 Series mounts and accessories provide excellent value at an attractive price, featuring simple, clean lines, and rugged construction for a wide range of mounting options.



HA30JCB01  
Junction Box



HA30PMC01  
Pendant Mounting  
Cap



HA30PMC02  
Pendant Mounting  
Cap



HA30PMC03  
Pendant Mounting  
Cap



HA30PME01  
Pendant Mounting  
Pipe



HA30PME02  
Pendant Mounting  
Pipe



HA30PMB01  
Pendant Mounting  
Base



HA30WLM01  
Wall Mounting  
Bracket



HA30WLM03  
Wall Mounting  
Bracket



HA30PLM01  
Pole Mounting  
Adapter



HA30CNM01  
Corner Mounting  
Adapter

# MOUNTS AND ACCESSORIES

## DIMENSIONS

HA30JCB01

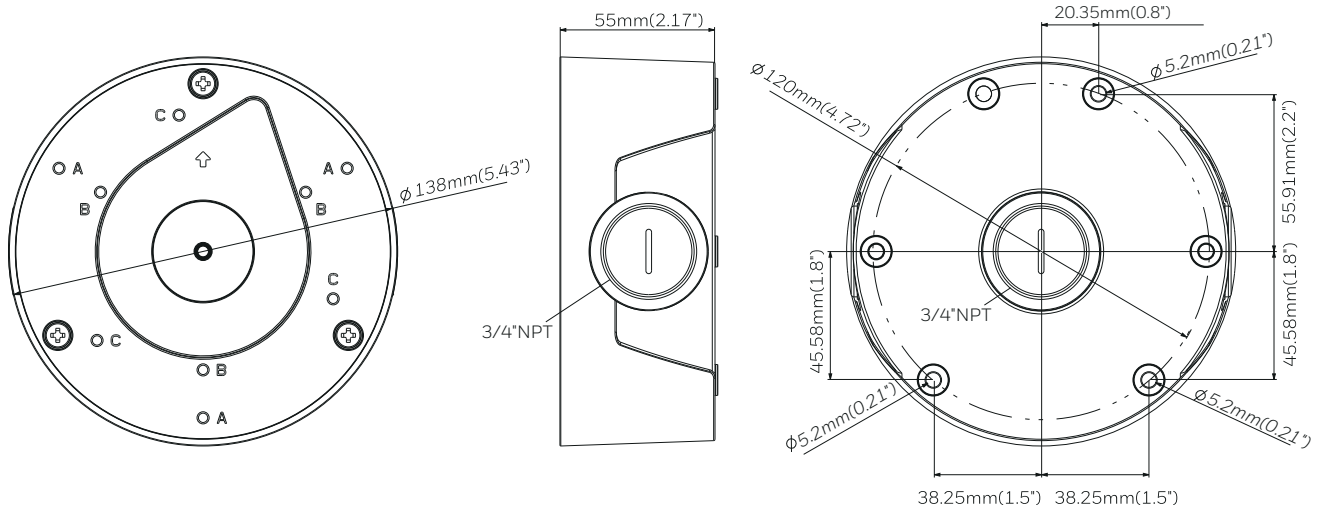

HA30PMC01

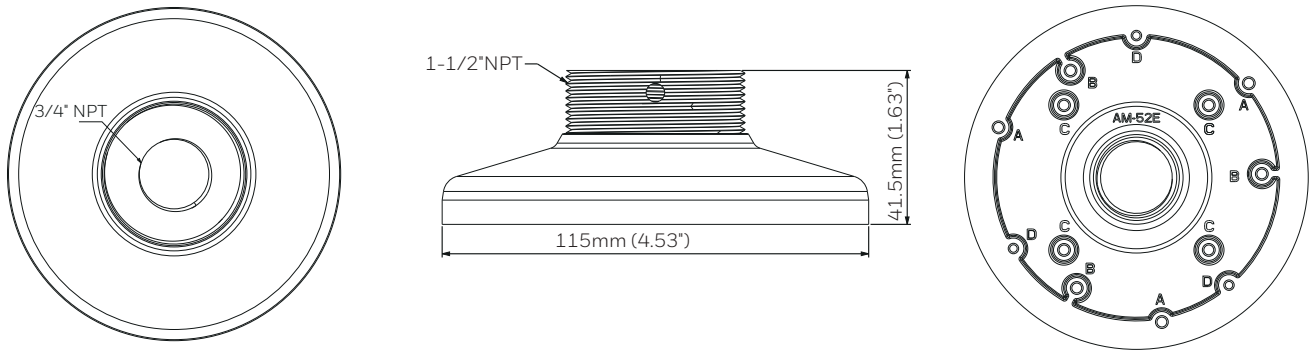

HA30PMC02

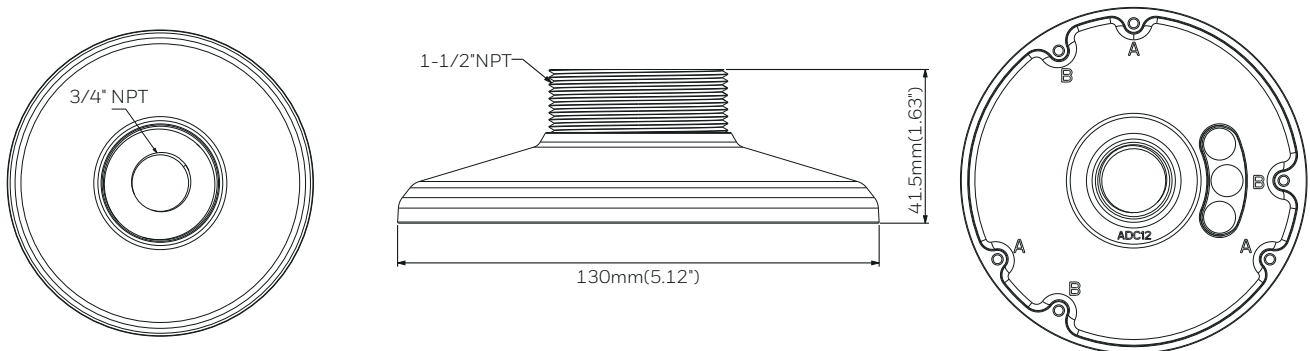

# MOUNTS AND ACCESSORIES

## DIMENSIONS

HA30PMC03

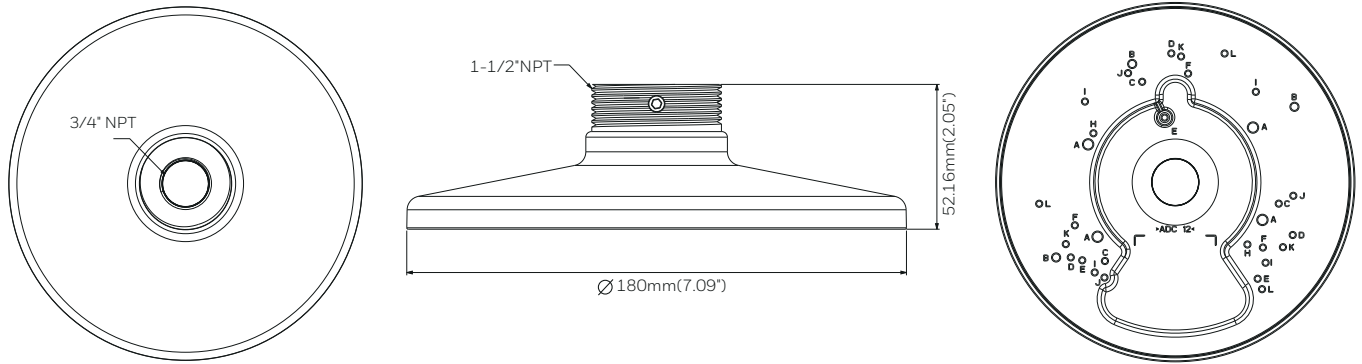

HA30PME01

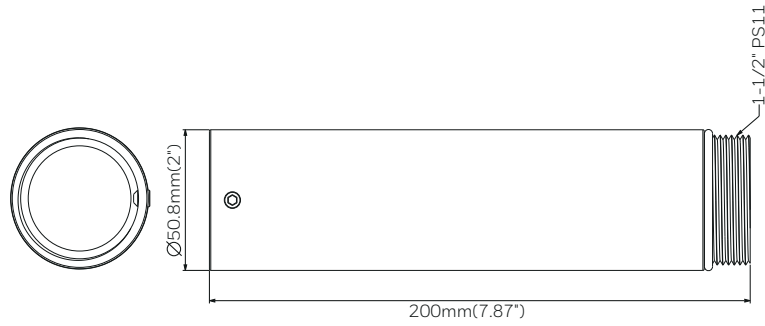

HA30PME02

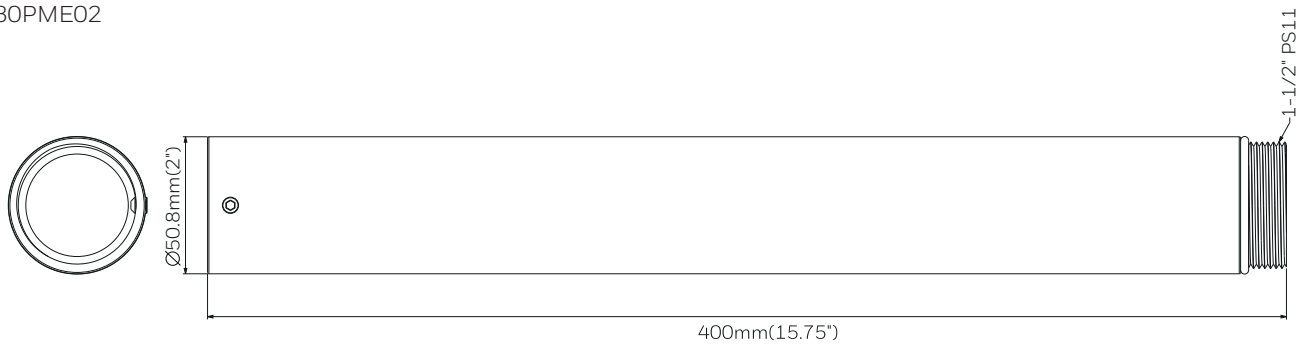

# MOUNTS AND ACCESSORIES

## DIMENSIONS

HA30PMB01

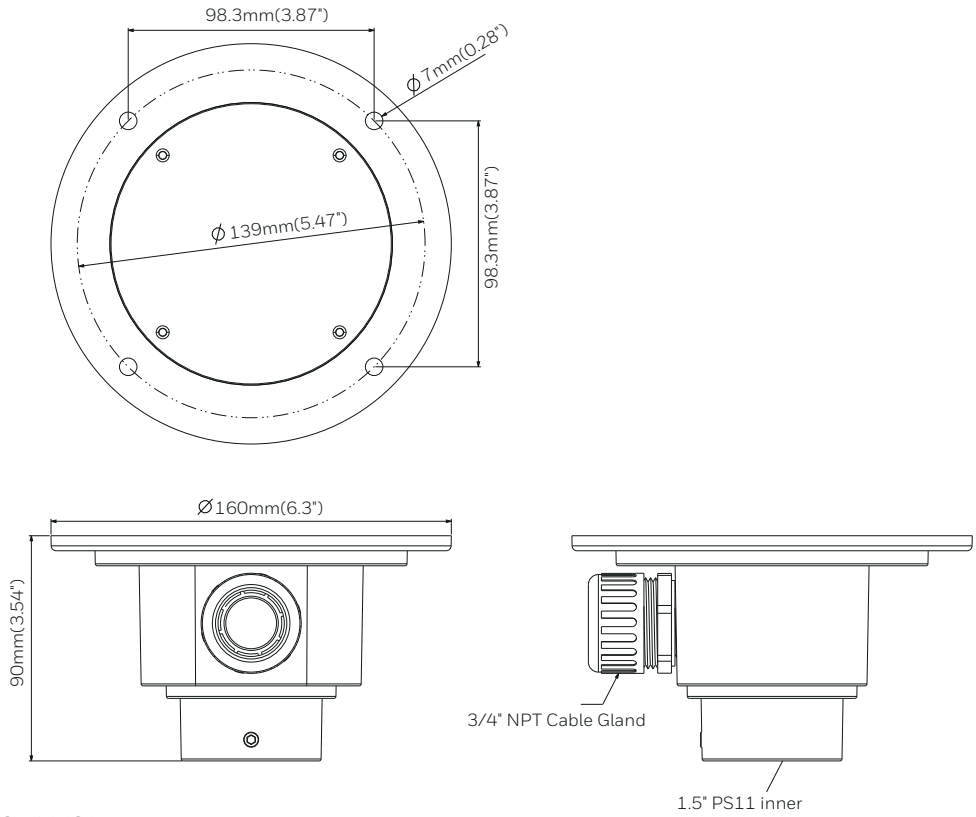

HA30WLM01

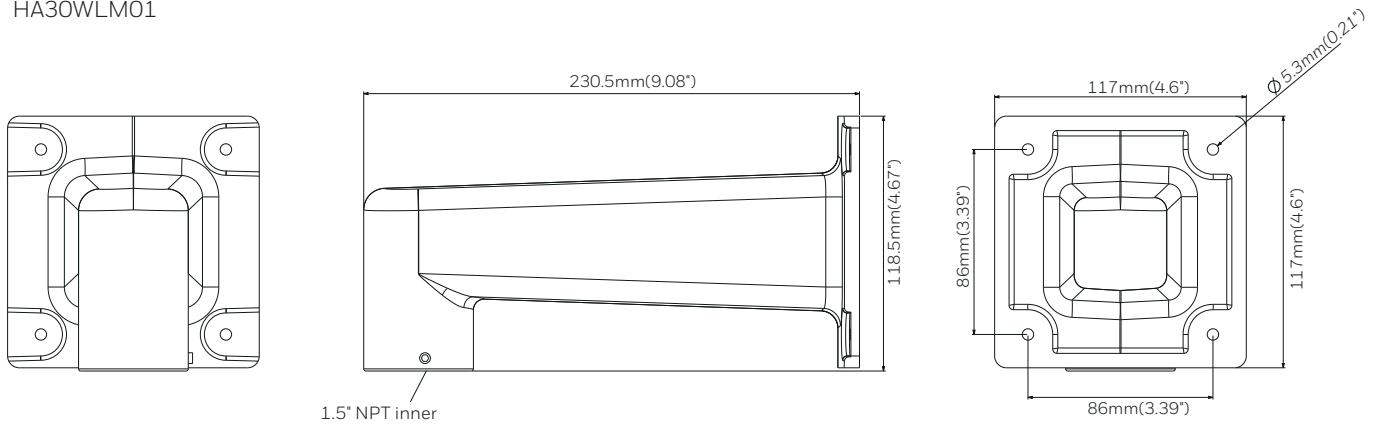

HA30WLM03

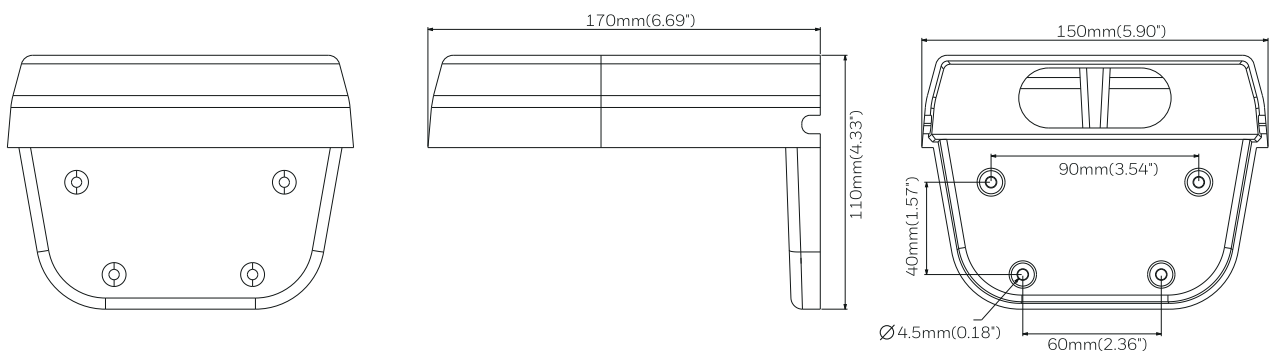

# MOUNTS AND ACCESSORIES

## DIMENSIONS

HA30PLM01

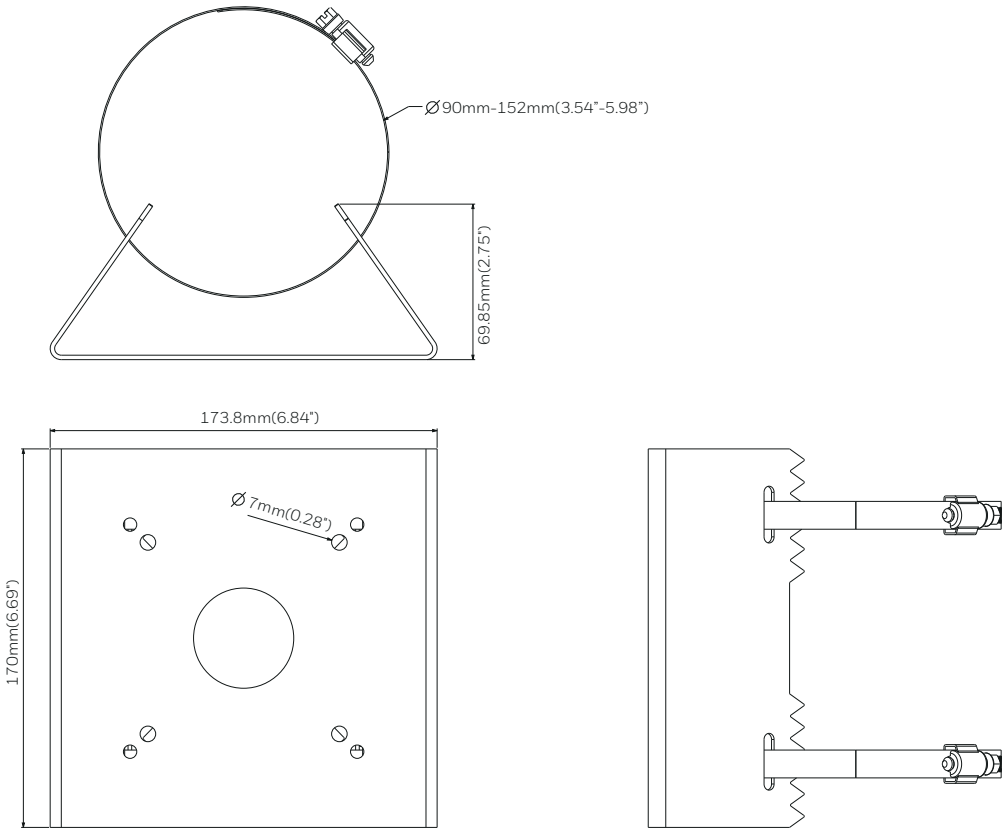



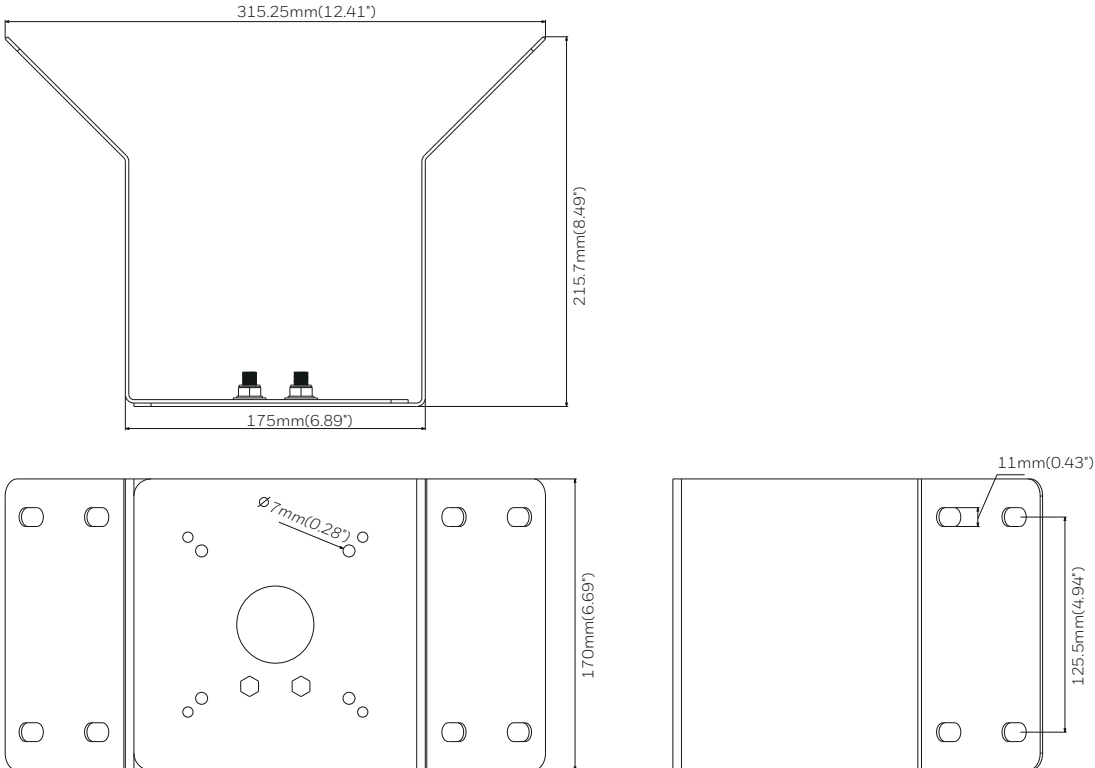





HA30CNM01



# MOUNTS AND ACCESSORIES

## COMPATIBLE CAMERAS

MODEL	HC30W42R3 HC30W45R3	HC30W45R2	HC30WB2R1 HC30WB5R1 HC30WB5R2	HC30WE2R3 HC30WE5R3	HC30WE5R2	HC30WF5R1
HA30JCB01 						
HA30PMC01 						
HA30PMC02 						
HA30PMC03 						
HA30PME01 	+HA30PME01 +HA30PMC01 	+HA30PME01 +HA30PMC02 		+HA30PME01 +HA30PMC01 	+HA30PME01 +HA30PMC01 	+HA30PME01 +HA30PMC03 
HA30PME02 	or +HA30PME02 +HA30PMC01 	or +HA30PME02 +HA30PMC02 		or +HA30PME02 +HA30PMC01 	or +HA30PME02 +HA30PMC01 	or +HA30PME02 +HA30PMC03 
HA30PMB01 						

# MOUNTS AND ACCESSORIES

## COMPATIBLE CAMERAS

MODEL	HC30W42R3 HC30W45R3	HC30W45R2	HC30WB2R1 HC30WB5R1 HC30WB5R2	HC30WE2R3 HC30WE5R3	HC30WE5R2	HC30WF5R1
HA30WLM01 	+HA30PMC01 	+HA30PMC02 		+HA30PMC01 	+HA30PMC01 	+HA30PMC03 
HA30WLM03 						
HA30PLM01 	+HA30WLM01 +HA30PMC01 	+HA30WLM01 +HA30PMC02 		+HA30WLM01 +HA30PMC01 	+HA30WLM01 +HA30PMC01 	+HA30WLM01 +HA30PMC03 
HA30CNM01 	+HA30WLM01 +HA30PMC01 	+HA30WLM01 +HA30PMC02 		+HA30WLM01 +HA30PMC01 	+HA30WLM01 +HA30PMC01 	+HA30WLM01 +HA30PMC03 

# MOUNTS AND ACCESSORIES

## SPECIFICATIONS

MODEL	UNIT WEIGHT	CONSTRUCTION	DIMENSIONS
HA30JCB01	1.92 lb (0.87 kg)	Die-casting aluminum	Ø 5.43 x 2.17 in. (Ø 138 x 55 mm)
HA30PMC01	0.54 lb (0.24 kg)	Die-casting aluminum	Ø 4.53 x 1.63 in. (Ø 115 x 41.5 mm)
HA30PMC02	0.42 lb (0.19 kg)	Die-casting aluminum	Ø 5.12 x 1.63 in. (Ø 130 x 41.5 mm)
HA30PMC03	1.70 lb (0.77 kg)	Die-casting aluminum	Ø 7.09 x 2.05 in. (Ø 180 x 52.16 mm)
HA30PME01	0.95 lb (0.43 kg)	Aluminum	Ø 2 x 7.87 in. (Ø 50.8 x 200 mm)
HA30PME02	1.98 lb (0.9 kg)	Aluminum	Ø 2 x 15.75 in. (Ø 50.8 x 400 mm)
HA30PMB01	1.63 lb (0.74 kg)	Die-casting aluminum and PC Gland	Ø 6.3 x 3.54 in. (Ø 160 x 90 mm)
HA30WLM01	1.46 lb (0.66 kg)	Die-casting aluminum	9.08 x 4.6 x 4.67 in. (230.5 x 117 x 118.5 mm)
HA30WLM03	1.28 lb (0.58 kg)	Die-casting aluminum and SECC steel	6.69 x 5.9 x 4.33 in. (170 x 150 x 110 mm)
HA30PLM01	2.65 lb (1.2 kg)	SECC Steel and SUS304	6.84 x 6.69 x 2.75 in. (173.8 x 170 x 69.85 mm)
HA30CNM01	4.85 lb (2.2 kg)	SECC Steel	12.41 x 8.49 x 6.69 in. (315.25 x 215.7 x 170 mm)

## ORDERING

MODEL	DESCRIPTION	MODEL	DESCRIPTION
HA30JCB01	30 Series Junction Box, Round	HA30PMB01	30 Series Pendant Mounting Base,
HA30PMC01	30 Series Pendant Mounting Cap, 3/4" NPT Female Connector	HA30WLM01	30 Series Wall Mounting Bracket
HA30PMC02	30 Series Pendant Mounting Cap, 3/4" NPT Female Connector	HA30WLM03	30 Series Wall Mounting Bracket
HA30PMC03	30 Series Pendant Mounting Cap, 3/4" NPT Female Connector	HA30PLM01	30 Series Pole Mounting Adapter
HA30PME01	30 Series Pendant Mounting Pipe, 20 cm	HA30CNM01	30 Series Corner Mounting Adapter
HA30PME02	30 Series Pendant Mounting Pipe, 40 cm		

### For more information

[www.security.honeywell.com](http://www.security.honeywell.com)

### Honeywell Commercial Security

715 Peachtree St. NE  
Atlanta, GA 30308  
1.800.323.4576  
[www.honeywell.com](http://www.honeywell.com)

Honeywell reserves the right, without notification, to make changes in product design or specifications.

HSFV-30\_MNTS\_ACC-02-US(0520)DS-Y  
© 2020 Honeywell International Inc.

**THE  
FUTURE  
IS  
WHAT  
WE  
MAKE IT**

**Honeywell**