



CHE-HDBTWP110K

Pro AV/IT HDBaseT 4K60 18G Single Gang Wall Plate
Extender Kit with HDMI, VGA, Audio up to 230ft



Operation Manual

SAFETY PRECAUTIONS

Please read all instructions before attempting to unpack, install or operate this equipment and before connecting the power supply.

Please keep the following in mind as you unpack and install this equipment:

- Always follow basic safety precautions to reduce the risk of fire, electrical shock and injury to persons.
- To prevent fire or shock hazard, do not expose the unit to rain, moisture or install this product near water.
- Never spill liquid of any kind on or into this product.
- Never push an object of any kind into this product through any openings or empty slots in the unit, as you may damage parts inside the unit.
- Do not attach the power supply cabling to buildingsurfaces.
- Use only the supplied power supply unit (PSU). Do not use the PSU if it is damaged.
- Do not allow anything to rest on the power cabling or allow any weight to be placed upon it or any person walk on it.
- To protect the unit from overheating, do not block any vents or openings in the unit housing that provide ventilation and allow for sufficient space for air to circulate around the unit.
- Please completely disconnect the power when the unit is not in use to avoid wasting electricity.

CONTENTS

1. Introduction	1
2. Applications	1
3. Package Contents	2
4. System Requirements	2
5. Features	2
6. Operation Controls and Functions	4
6.1 Front Panel.....	4
6.2 Rear Panel	5
6.3 WebGUI Control	6
6.3.1 Switch Tab	8
6.3.2 Automation Tab.....	10
6.3.3 EDID Settings Tab	12
6.3.4 System Settings Tab.....	14
6.4 RS-232 Control.....	15
6.5 Telnet Control.....	16
6.6 RS-232 and Telnet Commands	17
7. Connection Diagram	31
8. Specifications	32
8.1 Technical Specifications	32
8.2 Video Specifications	33
8.3 Audio Specifications	34
8.4 Cable Specifications	34
8.5 HDBaseT Features	35
9. Acronyms	36

1. INTRODUCTION

The CHE-HDBTWP110K Wallplate Extender is an HDMI and VGA switch with audio embedding and HDBaseT output. The wallplate is designed for use with US single-gang sized enclosures. This Transmitter can send uncompressed high-definition video/audio over a single cable up to a distance of 100 meters at 1080p@60Hz. The HDMI input supports resolutions up to 4K@60Hz (4:4:4, 8-bit) and the VGA input supports resolutions up to WUXGA (RB). With the use of the 3.5mm audio input, stereo audio may be embedded with VGA or DVI sources as well.

Despite HDBaseT's 10.2Gbps bandwidth limitation, high bandwidth 4K UHD HDMI video sources, up to and including 4K@60Hz (4:4:4, 8-bit), can be supported and will be automatically converted to 8-bit color, or the 4:2:0 color space when necessary.

Signal management features such as automatic switching based on input signal and hot plug detection enable convenient hands-free operation. A multi-function button on the face of the unit provides access to an information OSD as well as allowing manual input selection. When paired with a compatible Receiver, additional functionality such as EDID management, HDCP management and basic event automation (which can send customized RS-232 or CEC commands to external devices automatically) also becomes accessible.

This Transmitter (PD) may be powered locally or via 48V PoH from a compatible HDBaseT Receiver (PSE), which allows for greater flexibility in installations. The unit can be controlled via the front panel button with OSD. When paired with a compatible Receiver it may also be controlled via Web GUI, Telnet, and RS-232 making it exceptionally versatile.

2. APPLICATIONS

- Household entertainment sharing and control
- Lecture halls, auditoriums and classroom
- Houses of worship
- Conference rooms and boardrooms
- Hotel event spaces

3. PACKAGE CONTENTS

- 1×HDMI/VGA over HDBaseT Transmitter
- 1×2-pin Terminal Block
- 1×US 1-Gang Faceplate
- 1×HDMI over HDBaseT Receiver (PSE)
- 1×48V/0.83A DC Power Adaptor
- 1×Power Cord
- 1×Operation Manual

4. SYSTEM REQUIREMENTS

- HDMI or VGA source equipment such as a media player, video game console or set-top box.
- A compatible HDBaseT Receiver is required. An HDBaseT Receiver capable of supplying 48V PoH is recommended.
- The use of industry standard Cat.6, Cat.6a or Cat.7 cable is highly recommended.
- The use of “Premium High Speed HDMI” cable is highly recommended.

5. FEATURES

- HDMI 2.0 and DVI 1.0 compliant
- HDCP 2.2 and HDCP 1.x compliant
- 1 HDMI input
- 1 VGA input with 3.5mm mini-jack audio input
- Wall plate is designed for US one-gang sized enclosures
- Supports HDMI input resolutions up to 4K@60Hz (4:4:4, 8-bit)
- Supports VGA input resolutions up to WUXGA (RB)
- Analog stereo audio may be embedded with VGA or DVI/HDMI sources
- HDBaseT output supports resolutions up to 4K@60Hz (4:2:0, 8-bit) with automatic color space conversion of 4K@50/60Hz (4:4:4, 8-bit) or 4K@any (10/12-bit) sources
- Simultaneous transmission of uncompressed video, audio and

data over a single 100m/328ft Cat.5e/6/7 cable at 1080p60 and 70m/230ft at 4K

- HDBaseT feature support: HD Video and Audio, 100BaseT Ethernet, 48V PoH, and Control (bidirectional IR/RS-232 pass-through)
- Supports standard 48V PoH from Receiver (PSE) to Transmitter (PD) (compatible Transmitters only)

Notes:

- *The 48V PoH function is designed to power compatible Transmitter units only. Non-PoH Transmitters will need their own power supply. Other brands of Transmitter may not be compatible.*
- *The use of "Premium High Speed HDMI" cables is highly recommended for displaying 3D and 4K content and compatible display equipment is required.*
- Supports CEC bypass
- User activated information OSD
- Unit may be powered locally or via 48V PoH from a compatible HDBaseT Receiver (PSE)
- Supports manual input selection or automatic input selection with hot plug detection
- Basic signal event automation (via RS-232 or CEC w/ compatible Receiver)
- USB port supports firmware update and powering of 5V/500mA devices
- Front panel LEDs indicate HDCP mode, input source, and power
- Controllable via a multi-function front panel button with OSD, or via WebGUI, Telnet, and RS-232 (w/ compatible Receiver only)

6. OPERATION CONTROLS AND FUNCTIONS

6.1 Front Panel

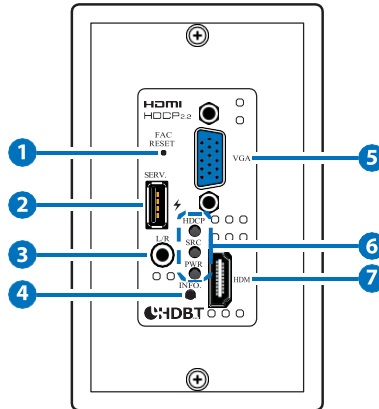

- 1 FAC RESET Button:** Press and hold for 5 seconds to reset the unit to its factory defaults.
- 2 SERV.:** This slot is reserved for firmware update use only.
Note: This USB port can provide up to 500mA to connected devices.
- 3 L/R IN:** Connect to the stereo analog output of a device such as an audio player or PC for embedding into the HDBaseT output.
- 4 INFO Button:** A short press of this button will switch between the available inputs. Pressing and holding this button for 2 seconds will activate the information OSD.
- 5 VGA IN:** Connect to VGA source equipment such as a PC or laptop.
- 6 HDCP LED:** This LED indicates the HDCP mode of the current input. Green indicates Follow Display mode, orange indicates Follow Source mode, off indicates HDCP is disabled.
SRC LED: This LED indicates which source is currently selected. Green indicates the HDMI input, orange indicates the VGA input.
PWR LED: This LED will illuminate to indicate the unit's power and link status. Orange indicates the unit is on and receiving power, green indicates the unit is on, receiving power, and has successfully

linked to a compatible Receiver.

- HDMI IN:** Connect to HDMI source equipment such as a media player, game console or set-top box.

6.2 Rear Panel

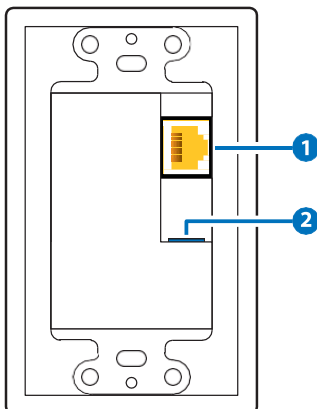

- CAT5e/6/7 OUT:** Connect to a compatible HDBaseT Receiver with a single Cat.5e/6/7 cable for transmission of all data signals.
- DC 12V:** Connect a 12V DC power adapter to the twin terminal block and connect it to an AC wall outlet for power. (Optional, not required when powered by PoH from the Receiver.)

Receiver's Front and Rear Panels



- STD/UPDATE:** This switch is reserved for factory use only.
- RS-232 OUT:** Connect to a serial controllable device for the extension of RS-232 signals.

- 3 **LAN:** Connect to an Ethernet device or to your local network as appropriate.
- 4 **POWER LED:** This LED will illuminate to indicate the unit is on and receiving power.
- 5 **LINK LED:** This LED will illuminate solid when both Transmitter and Receiver are connected and communicating with each other properly.
- 6 **DC 48V:** Plug the 48V DC power adapter into this port and connect it to an AC wall outlet for power.
- 7 **IR1:** Not functional
- 8 **IR2 :** Not functional
- 9 **CAT5e/6/7 IN:** Connect to a compatible HDBaseT Transmitter with a single Cat.5e/6/7 cable for transmission of all data signals.
- 10 **HDMI OUT:** Connect to an HDMI TV, monitor or amplifier for digital video and audio output.

6.3 WebGUI Control

• Device Discovery APP

Please obtain the “Device Discovery” software from your authorized dealer and save it in a directory where you can easily find it.

Connect the unit and your PC/Laptop to the same active network and execute the “Device Discovery” software. Click on “Find Devices on Network” and a list of devices connected to the local network will show up indicating their current IP address.

Note: The unit's default IP address is 192.168.1.50.



Product Name	Description	IP Address	MAC Address

By clicking on one of the listed devices you will be presented with the network details of that particular device.

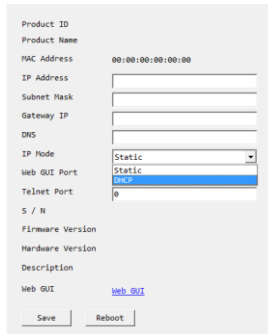

Product ID
Product Name
MAC Address 00:00:00:00:00:00
IP Address
Subnet Mask
Gateway IP
DNS
IP Mode Static
Web GUI Port Static
Telnet Port 0
S / N
Firmware Version
Hardware Version
Description
Web GUI [Web GUI](#)
Save Reboot

- 1) IP Mode:** If you choose, you can alter the static IP network settings for the device, or switch the unit into DHCP mode to automatically obtain proper network settings from a local DHCP server. To switch to DHCP mode, please select DHCP from the IP mode drop-down, then click “Save” followed by “Reboot”.
- 2) WebGUI Hotkey:** Once you are satisfied with the network settings, you may use them to connect via Telnet or WebGUI. The network information window provides a convenient link to launch the WebGUI directly.

Note: WebGUI support requires the use of a compatible HDBaseT Receiver with an Ethernet port.

- **WebGUI Overview**

After connecting to the WebGUI's address in a web browser, the login screen will appear. Please enter the appropriate user name and password then click "Submit" to log in.

Note: The default user name and password is "admin".

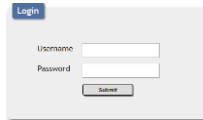

A screenshot of a login form. At the top left is a blue tab labeled "Login". Below it are two input fields: "Username" and "Password". At the bottom center is a "Submit" button.

On the left side of the browser you will see the following menu tabs where all primary functions of the unit (Switch, Automation, EDID Settings and System Settings) are controllable via the built in WebGUI. The individual functions will be introduced in the following sections.

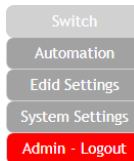

Clicking the red "Logout" tab will automatically log the currently connected user out of the WebGUI and return to login page.

6.3.1 Switch Tab

This tab provides video/audio routing control as well as control over HDCP behavior, freerun settings, and naming of the Inputs and Output. To assign a new video route, please click the Output button and then click on the button of the preferred Input port to route. As you select each button they will change their color to orange. The new route will become active immediately and the routing information displayed on the buttons will change accordingly.

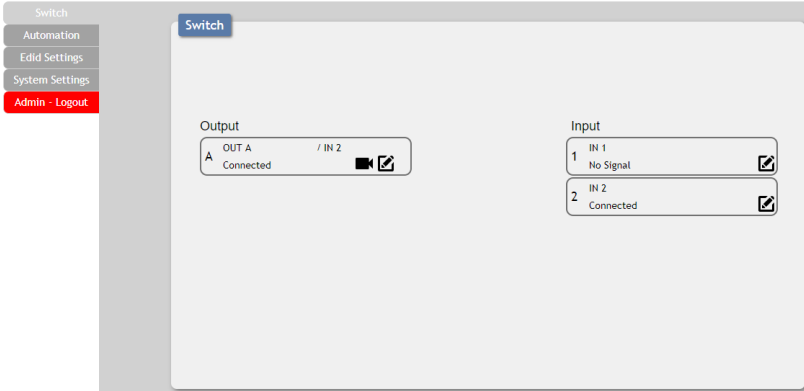

- 1) **Output:** Click on the main button to begin routing selection. Click on the Camera icon (📷) to mute or unmute the output. Click the Edit icon (✎) to modify additional Output settings.

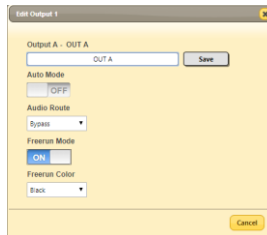

- 2) **Edit Output:** This window provides options to rename the Output, enable auto switching, set audio routing, and configure freerun.
 - **Output Name:** Provides a way to change the name of the Output port. Click on "Save" to confirm and activate any changes.
 - **Auto Mode:** Enable or disable the auto input switching mode.

- **Audio Route:** Control the audio used when the HDMI input is active. Selecting “Bypass” will use the HDMI signal’s normal audio. Selecting “External” will use the analog stereo audio.
 - **Freerun Mode:** Enable or disable the video freerun function. When this is enabled, the selected freerun color will be displayed on the screen if there is no live source on the selected input.
 - **Freerun Color:** Select the color to display when freerun is active. Available choices are: Black, Red, Blue, and Colorbars.
- 3) Input:** Rename either Input or modify the HDCP behavior (Input 2 only) by clicking on the Edit icon (✎) to open the editing window. Click on “Save” to confirm and activate any changes made to a name. Changes made to the HDCP behavior are applied immediately.
- **Apple Mode:** Completely disables HDCP support on the input.
 - **Follow In:** HDCP support follows the HDCP mode required by the connected source device.
 - **Follow Out:** HDCP support follows the HDCP mode supported by the connected sink.

6.3.2 Automation Tab

The Automation tab provides control over the unit's automatic control command broadcast behavior when the specified system Automation Events occur. Automation commands may be sent to 3rd party devices via standard CEC, or customizable RS-232.

Note: Sending RS-232 commands requires the use of a compatible HDBaseT Receiver with an RS-232 port.

The screenshot displays the 'Automation' configuration page. On the left, a sidebar contains navigation links: 'Switch', 'Automation', 'Edit Settings', 'System Settings', and 'Admin - Logout'. The main content area is titled 'Automation' and is divided into three sections:

- Event:** A dropdown menu is set to '1 - Power On'.
- CEC:** A toggle switch is turned 'OFF'. Below it, 'Delay' and 'Wait' are both set to '1 sec'. The 'CEC Command' dropdown is set to 'Power On', with a 'Test' button to its right.
- RS232:** A toggle switch is turned 'OFF'. Below it, 'Delay' and 'Wait' are both set to '1 sec'. The 'RS232 Command' text field contains 'set power on all', followed by checkboxes for 'LF', 'CR', and a copy icon, and a 'Test' button.
- RS232 Setting:** A 'Mode' dropdown is set to 'Console'. Below it, 'Baudrate' is '19200', 'Data Length' is '8', 'Parity Bit' is 'None', and 'Stop Bit' is '1'. There is a copy icon to the right of the Baudrate and Data Length fields.

- 1) **Event:** Use the dropdown to select the Automation Event to configure. Available Automation Events are:
- **Power On:** This unit is powered on.
 - **Out A Source Active:** The currently selected input changes from inactive to active.
 - **Out A Source Lost:** The currently selected input changes from active to inactive.
- **CEC:** Enable or disable sending a CEC command when the currently selected Automation Event is activated.
- Note: CEC support must be enabled on the connected HDMI device.*
- **Delay:** Set the length of time, in seconds, that the specified Automation Event must continue to be true before sending the defined CEC command.

- **Wait:** Set the length of time, in seconds, to wait after this CEC Automation Event has been activated before ANY other Automation Event can be detected.
- **CEC Command:** Set the CEC command to send when the specified Automation Event is activated. Clicking the "Test" button will send the command immediately. Available CEC commands are:
 - **Power Off:** Turn off the connected HDMI display device.
 - **Power On:** Turn on the connected HDMI display device.
 - **Active Source:** Force the connected HDMI display device to switch to the HDMI input that this unit is connected to.

Note: Not all HDMI devices support all CEC commands.

- **RS-232:** Enable or disable sending an RS-232 command when the currently selected Automation Event is activated.

Note: The RS-232 port must be in "Control" mode to send commands to external devices.

- **Delay:** Set the length of time, in seconds, that the specified Automation Event must continue to be true before sending the defined RS-232 command.
- **Wait:** Set the length of time, in seconds, to wait after this RS-232 Automation Event has been activated before ANY other Automation Event can be detected.
- **RS-232 Command:** Click the Edit icon (✎) to define the RS-232 command to send when the specified Automation Event is activated. Clicking the "Test" button will send the command immediately.

2) RS-232 Setting: Provides controls to configure the settings and behavior of the RS-232 port.

- **Mode:** Switch the behavior of the RS-232 port between "Console" and "Control". When "Console" is selected, the unit can receive and be controlled directly via RS-232 commands. When "Control" is selected the RS-232 port can send Automation commands to control other devices.
- **RS-232 Setting Edit:** Click on the Edit icon (✎) to configure the various RS-232 port settings including baud rate, data length, parity and stop bits.

6.3.3 EDID Settings Tab

This tab provides control over the EDID behavior of the unit. There are six internal EDIDs, two customer uploaded EDIDs, and one sink sourced EDID that can be assigned to each input port individually. The sink EDID and both Customer EDIDs are also available for download to the connected PC.



- 1) Customer EDID Settings:** Manage the uploadable User EDID content.
 - **Save Name:** Type the preferred name for the User EDID in the space provided then click “Save Name” to confirm the change.
 - **Download:** Click to download and save the current User EDID as a file (*.bin) on the connected PC.
 - **Upload:** Click to upload a previously saved EDID file (*.bin) from the connected PC into the User EDID slot.
- 2) Sink EDID Download:** Select and save the EDID from a connected display.
 - **Drop-down Menu:** Select the sink to read an EDID from for download.
 - **Download:** Click to download the EDID from the selected sink as a file (*.bin) to the connected PC.
- 3) EDID Mode:** This dropdown controls how EDIDs are assigned to the unit's Inputs.

- **All:** Selecting this will allow the assignment of a single EDID to all Inputs simultaneously.
 - **Apport:** Selecting this allows for a different EDID to be assigned to each Input.
- 4) **Set EDID Input Content:** This section provides a way to set the EDID to use with the selected Input.
- **IN 1/IN 2/All Input:** Click the appropriate buttons to select the preferred Input(s) and open the EDID Source table for assigning an EDID.
 - **EDID Source:** Click the EDID to assign to the selected Input. Once the EDID has been selected, the change will occur immediately.

The EDIDs available in the EDID Source table are:

EDID Source	EDID Content
8bit/2D/PCM/1080p/2CH	1080p@60Hz, LPCM 2.0
8bit/2D/PCM/1080p/MCH	1080p@60Hz, LPCM 7.1+Bitstream
12bit/2D/PCM/4K2K@30/2CH	4K@30Hz, LPCM 2.0
12bit/2D/PCM/4K2K@30/MCH	4K@30Hz, LPCM 7.1+Bitstream
12bit/2D/PCM/4K2K@60/2CH	4K@60Hz, LPCM 2.0
12bit/2D/PCM/4K2K@60/MCH	4K@60Hz, LPCM 7.1+Bitstream
USER 1	The currently uploaded Customer EDID
USER 2	The currently uploaded Customer EDID
SINK A	EDID from the device on Output A

6.3.4 System Settings Tab

This tab provides access to control a number of system configuration controls including displaying the unit's serial number, modifying the web access privileges, changing the IP configuration, performing a factory reset, rebooting the system, and updating the firmware.

The screenshot displays the 'System Settings' web interface. On the left is a sidebar with menu items: 'Switch', 'Automation', 'Edid Settings', 'System Settings' (which is highlighted in blue), and 'Admin - Logout' (in red). The main panel is titled 'System Settings' and is divided into several sections. The 'Serial Number' section has a single text input field. The 'Web User Setting' section includes a 'Username' field with 'admin' entered, and three password fields: 'Old Password', 'New Password', and 'Confirm Password', with a 'Save' button to the right. The 'NetWork' section features an 'IP Mode' dropdown set to 'STATIC IP', and input fields for 'IP' (192.168.1.50), 'Netmask' (255.255.255.0), and 'Gateway' (192.168.1.254), with a 'MAC Address' field below. A 'Save' button is positioned to the right of the IP, Netmask, and Gateway fields. The 'System' section contains two buttons: 'Reboot' and 'Factory Default'. The 'Firmware Upgrade' section has a 'Choose File' button (showing 'No file chosen') and an 'Upgrade' button.

- 1) **Serial Number:** Displays the unit's serial number.
- 2) **Web User Setting:** This section provides a way to change the password for the Administrator account. Click on "Save" to confirm and activate any changes made to these settings.

Note: The default password is "admin".

- 3) **Network:** The IP Address, Netmask and Gateway can be set manually, or DHCP can be enabled for automatic IP Configuration if your local network supports it. Click on "Save" to confirm and activate any changes made to these settings.

Note: If the IP address is changed then the IP address required for WebGUI and Telnet access will also change accordingly.

4) System

- **Reboot:** Click this button to reboot the unit.
- **Factory Default:** Click this button to reset the unit to the factory default settings.

- 5) **Firmware Upgrade:** To update the unit's firmware, click the "Choose File" button to open the file selection window and then select

the firmware update file (*.bin format) located on your local PC. After selecting the file, click the “Upgrade” button to begin the firmware update process. Once the process completes the unit will automatically reboot.

6.4 RS-232 Control

Unit		Controlling PC		Serial Port Settings	
Pin	Definition	Pin	Definition		
1	NC	1	NC	Baud Rate	19200
2	TxD	2	RxD	Data Bits	8
3	RxD	3	TxD	Parity Bit	None
4	NC	4	NC	Stop Bits	1
5	GND	5	GND	Flow Control	None
6	NC	6	NC		
7	NC	7	NC		
8	NC	8	NC		
9	NC	9	NC		

Note: RS-232 support requires the use of a compatible HDBaseT Receiver with an RS-232 port.

6.5 Telnet Control

Before attempting to use Telnet control, please ensure that both the unit and the PC are connected to the same active networks.

To Access the Command Line Interface (CLI)	
Windows 7	Click Start , type "cmd" in the search field, and press Enter .
Windows XP	Click Start > Run , type "cmd", and press Enter .
Mac OS X	Click Go > Applications > Utilities > Terminal .

Once in the Command Line Interface (CLI) type "**telnet**" followed by the IP address of the unit (and the port number if it is non-standard) and then hit "Enter". This will connect us to the unit we wish to control. Type "**help**" to list the available commands. See below for reference.

```
Microsoft Windows [Version 6.1.7601]
Copyright (c) 2009 Microsoft Corporation. All rights reserved.
C:\Users\Administrator>telnet 192.168.1.50 23
```

Note: The default IP address is 192.168.1.50. If the IP address is changed then the IP address required for Telnet access will also change accordingly. Telnet support requires the use of a compatible HDBaseT Receiver with an Ethernet port.

6.6 RS-232 and Telnet Commands

COMMAND	
Description and Parameters	
HELP↵	
	Show all available commands.
?↵	
	Show all available commands.
GET FW VER↵	
	Show the unit's firmware version.
GET MODEL NAME↵	
	Show the unit's model name.
GET MODEL TYPE↵	
	Show the unit's product type.
SET FACTORY DEFAULT↵	
	Reset the unit to its factory defaults.
SET FACTORY IPCONFIG DEFAULT↵	
	Reset the unit's IP configuration to the factory defaults.
SET SYSTEM REBOOT↵	
	Reboot the unit.
GET MAC 1 ADDR↵	
	Show the unit's MAC address.
SET IP MODE N1↵	
	Set the IP address assignment mode. Available values for N1 : STATIC [Static IP mode] DHCP [DHCP mode]
GET IP MODE↵	
	Show the current IP mode.

COMMAND	
Description and Parameters	
GET IPCONFIG ↵	
	Show the current IP address details.
SET IPADDR N1 ↵	
	Set the static IP Address.
N1 = X.X.X.X	[X = 0 ~ 255]
GET IPADDR ↵	
	Show the current IP address.
SET NETMASK N1 ↵	
	Set the netmask address.
N1 = X.X.X.X	[X = 0 ~ 255]
GET NETMASK ↵	
	Show the current netmask.
SET GATEWAY N1 ↵	
	Set the gateway address.
N1 = X.X.X.X	[X = 0 ~ 255]
GET GATEWAY ↵	
	Show the current gateway.
SET IN N1 NAME N2 ↵	
	Set the name of input N1 .
N1 = 1 ~ 2	[Input number]
N2 = {Name}	[16 characters max]
GET IN N1 NAME ↵	
	Show input N1 's current name.
N1 = 1 ~ 2	[Input number]
SET OUT A NAME N1 ↵	
	Set the name of the output.
N1 = {Name}	[16 characters max]

COMMAND	
Description and Parameters	
GET OUT A NAME↵	
	Show the output's current name.
SET OUT A ROUTE N1↵	
	Switch the output routing source to input N1 .
N1 = 1 ~ 2	[Input number]
GET OUT A ROUTE↵	
	Show the output's current routing source.
GET IN TYPE LIST↵	
	Show each input's video type.
GET OUT TYPE LIST↵	
	Show the video type of the output.
SET OUT A MASK N1↵	
	Enable or disable the mask setting on output N1 .
	Available values for N1 :
OFF	[Mask disabled]
ON	[Mask enabled]
	<i>Note: When an output is masked, all video, including the banner, will be blanked out.</i>
GET OUT A MASK↵	
	Display the current output mask setting.
SET OUT AUTO MODE N1↵	
	Enable or disable automatic source switching.
	Available values for N1 :
0	[Auto switch disabled]
1	[Auto switch enabled]
GET OUT AUTO MODE↵	
	Show the current auto switch mode state.

COMMAND	
Description and Parameters	
GET IN PORT NUMBER↵	
	Show the number of inputs on the unit.
GET OUT PORT NUMBER↵	
	Show the number of outputs on the unit.
GET IN N1 SYNC STATUS↵	
	Show the current sync status of input N1 .
N1 = 1 ~ 2	[Input number]
Available Responses:	
0	[No sync]
1	[Sync is present]
GET OUT A SYNC STATUS↵	
	Show the current sync status of the output.
Available Responses:	
0	[No sync]
1	[Sync is active]
SET ALL IN EDID MODE N1↵	
	Enable or disable using the same EDID for all inputs.
Available values for N1 :	
ON	[All mode]
OFF	[Appoint mode]
GET ALL IN EDID MODE↵	
	Show the current state of the EDID assignment mode.

COMMAND

Description and Parameters

SET ALL IN EDID **N1**↵

Set the EDID to use when set to "All mode".

Available values for **N1**:

1	[8-bit/1080p/2CH LPCM]
2	[8-bit/1080p/MCH]
3	[12-bit/4K@30/2CH LPCM]
4	[12-bit/4K@30/MCH]
5	[12-bit/4K@60/2CH LPCM]
6	[12-bit/4K@60/MCH]
7	[User 1]
8	[User 2]
9	[Sink A]

GET ALL IN EDID↵

Show the current "All mode" EDID.

SET IN **N1** EDID **N2**↵

Assign EDID **N2** to input **N1** in "Appoint mode".

N1 = 1 ~ 2 [Input number]

Available values for **N1**:

1	[8-bit/1080p/2CH LPCM]
2	[8-bit/1080p/MCH]
3	[12-bit/4K@30/2CH LPCM]
4	[12-bit/4K@30/MCH]
5	[12-bit/4K@60/2CH LPCM]
6	[12-bit/4K@60/MCH]
7	[User 1]
8	[User 2]
9	[Sink A]

GET IN **N1** EDID↵

Show the EDID currently assigned to input **N1**.

N1 = 1 ~ 2 [Input number]

COMMAND	
Description and Parameters	
GET IN EDID LIST↵	
	List all available EDID sources.
SET EDID N1 NAME N2↵	
	Set the name of User EDID N1 to N2 .
N1 = 7 ~ 8	[EDID number]
N2 = {Name}	[16 characters max]
	<i>Note: Only User EDIDs can be renamed.</i>
GET EDID N1 NAME↵	
	Show the current name of user EDID N1 .
N1 = 7 ~ 8	[EDID number]
SET IN 2 HDCP MODE N1↵	
	Set the HDCP mode to use with the HDMI input.
	Available values for N1 :
0	[HDCP disabled]
1	[Follow source]
2	[Follow display]
GET IN 2 HDCP MODE↵	
	Show the current HDCP mode.
SET AUDIO OUT A ROUTE N1↵	
	Set the audio source to use with the HDMI input.
	Available values for N1 :
1	[HDMI audio]
2	[Analog audio]
GET AUDIO OUT A ROUTE↵	
	Show the current HDMI audio source.

COMMAND

Description and Parameters

SET FREERUN A MODE N1↵

Enable or disable the freerun feature when there is no detected input.

Available values for **N1**:

ON [Freerun enabled]

OFF [Freerun disabled]

GET FREERUN A MODE↵

Show the current state of the freerun function.

SET FREERUN A TYPE N1↵

Set the color to display when freerun is enabled and active.

Available values for **N1**:

1 [Black]

3 [Red]

5 [Blue]

10 [Color bar]

SET FREERUN A TYPE↵

Show the current freerun display color.

GET FREERUN LIST↵

List all available freerun colors.

GET AUTOMATION EVENT LIST↵

List all Automation Event types.

COMMAND

Description and Parameters

SET AUTOMATION EVENT N1 UART N2↵

Enable or disable the specified Automation Event's RS-232 response.

Available values for **N1**:

1	[Power on]
2	[Out A source active]
3	[Out A source lost]

Available values for **N2**:

ON	[Event enabled]
OFF	[Event disabled]

GET AUTOMATION EVENT N1 UART↵

Show the current state of the specified Automation Event's RS-232 response.

Available values for **N1**:

1	[Power on]
2	[Out A source active]
3	[Out A source lost]

SET AUTOMATION EVENT N1 UART DELAY N2 SEC↵

Set the delay time that the specified Automation Event must continue to be true before sending the defined RS-232 command.

Available values for **N1**:

1	[Power on]
2	[Out A source active]
3	[Out A source lost]

N2 = 1 ~ 300 [Delay in seconds]

COMMAND

Description and Parameters

GET AUTOMATION EVENT N1 UART DELAY←

Show the delay time for the specified Automation Event's RS-232 response.

Available values for **N1**:

1	[Power on]
2	[Out A source active]
3	[Out A source lost]

SET AUTOMATION EVENT N1 UART WAIT N2 SEC←

Set the length of time to wait after an Automation Event's RS-232 response has been activated before ANY other Automation Event can be detected.

Available values for **N1**:

1	[Power on]
2	[Out A source active]
3	[Out A source lost]

N2 = 1 ~ 300 [Wait time in seconds]

Note: If both an RS-232 and CEC event is activated by the same Automation Event, the longer of the 2 wait times will be used.

GET AUTOMATION EVENT N1 UART WAIT←

Show the wait time for the specified Automation Event's RS-232 response.

Available values for **N1**:

1	[Power on]
2	[Out A source active]
3	[Out A source lost]

COMMAND

Description and Parameters

SET AUTOMATION EVENT N1 UART COMMAND N2↵

Set the RS-232 command string to send when the specified Automation Event is activated.

Available values for **N1**:

- | | |
|---|-----------------------|
| 1 | [Power on] |
| 2 | [Out A source active] |
| 3 | [Out A source lost] |

N2 = {Command} [Max 32 characters]

GET AUTOMATION EVENT N1 UART COMMAND↵

Show the RS-232 command string to be sent when the specified Automation Event is activated.

Available values for **N1**:

- | | |
|---|-----------------------|
| 1 | [Power on] |
| 2 | [Out A source active] |
| 3 | [Out A source lost] |

SET AUTOMATION EVENT N1 CEC N2↵

Enable or disable the specified Automation Event's CEC response.

Available values for **N1**:

- | | |
|---|-----------------------|
| 1 | [Power on] |
| 2 | [Out A source active] |
| 3 | [Out A source lost] |

Available values for **N2**:

- | | |
|-----|------------------|
| ON | [Event enabled] |
| OFF | [Event disabled] |

COMMAND

Description and Parameters

GET AUTOMATION EVENT N1 CEC↵

Show the current state of the specified Automation Event's CEC response.

Available values for **N1**:

1	[Power on]
2	[Out A source active]
3	[Out A source lost]

SET AUTOMATION EVENT N1 CEC DELAY N2 SEC↵

Set the delay time that the specified Automation Event must continue to be true before sending the defined CEC command.

Available values for **N1**:

1	[Power on]
2	[Out A source active]
3	[Out A source lost]

N2 = 1 ~ 300 [Delay in seconds]

GET AUTOMATION EVENT N1 CEC DELAY↵

Show the delay time for the specified Automation Event's CEC response.

Available values for **N1**:

1	[Power on]
2	[Out A source active]
3	[Out A source lost]

COMMAND

Description and Parameters

SET AUTOMATION EVENT N1 CEC WAIT N2 SEC↵

Set the length of time to wait after an Automation Event's CEC response has been activated before ANY other Automation Event can be detected.

Available values for **N1**:

- | | |
|---|-----------------------|
| 1 | [Power on] |
| 2 | [Out A source active] |
| 3 | [Out A source lost] |

N2 = 1 ~ 300 [Wait time in seconds]

Note: If both an RS-232 and CEC event is activated by the same Automation Event, the longer of the 2 wait times will be used.

GET AUTOMATION EVENT N1 CEC WAIT↵

Show the wait time for the specified Automation Event's CEC response.

Available values for **N1**:

- | | |
|---|-----------------------|
| 1 | [Power on] |
| 2 | [Out A source active] |
| 3 | [Out A source lost] |

SET AUTOMATION EVENT N1 CEC COMMAND N2↵

Set the CEC command to send when the specified Automation Event is activated.

Available values for **N1**:

- | | |
|---|-----------------------|
| 1 | [Power on] |
| 2 | [Out A source active] |
| 3 | [Out A source lost] |

Available values for **N2**:

- | | |
|---|---------------------|
| 1 | [CEC power off] |
| 2 | [CEC power on] |
| 3 | [CEC active source] |

COMMAND

Description and Parameters

GET AUTOMATION EVENT N1 CEC COMMAND↵

Show the CEC command to be sent when the specified Automation Event is activated.

Available values for **N1**:

1	[Power on]
2	[Out A source active]
3	[Out A source lost]

SET UART 1 MODE N1↵

Set the RS-232 operation mode of the unit.

Available values for **N1**:

1	[Console Commands]
2	[Control]

GET UART 1 MODE↵

Show the current RS-232 operation mode.

SET UART 1 BAUDRATE N1↵

Set the RS-232 baud rate.

Available values for **N1**:

4800	[Baud rate]
7200	[Baud rate]
9600	[Baud rate]
14400	[Baud rate]
19200	[Baud rate]
38400	[Baud rate]
57600	[Baud rate]
115200	[Baud rate]

GET UART 1 BAUDRATE↵

Show the current RS-232 baud rate.

COMMAND	
Description and Parameters	
SET UART 1 STOP BIT N1↵	
	Set the number of RS-232 stop bits to use. N1 = 1 ~ 2
GET UART 1 STOP BIT↵	
	Show the current RS-232 stop bits setting.
SET UART 1 DATA BIT N1↵	
	Set the number of RS-232 data bits to use. N1 = 5 ~ 8
GET UART 1 DATA BIT↵	
	Show the current RS-232 data bits setting.
SET UART 1 PARITY N1↵	
	Set the parity value for RS-232. Available values for N1 :
0	[None]
1	[Odd]
2	[Even]
GET UART 1 PARITY↵	
	Show the current RS-232 parity setting.

Note: Commands will not be executed unless followed by a carriage return. Commands are not case-sensitive.

7. CONNECTION DIAGRAM

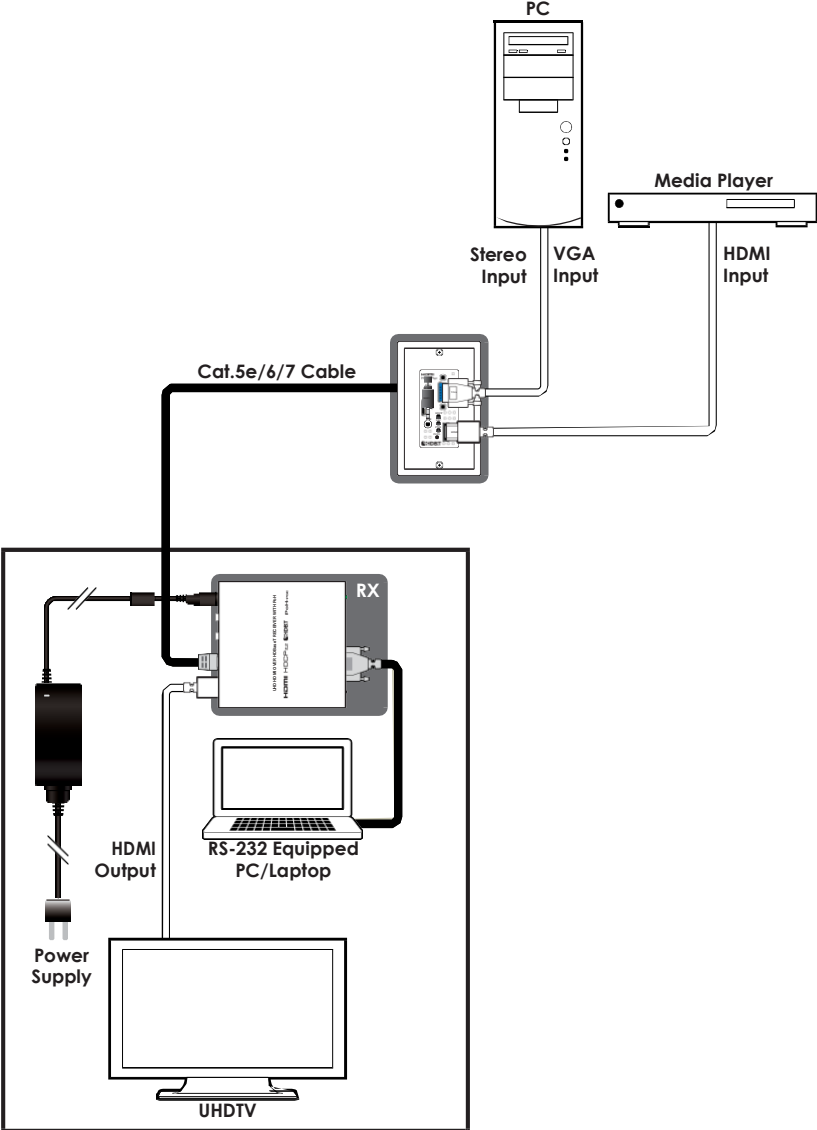

8. SPECIFICATIONS

8.1 Technical Specifications (Transmitter)

HDMI Bandwidth	600MHz/18Gbps
HDBaseT Bandwidth	340MHz/10.2Gbps
Input Ports	1×HDMI 1×VGA (HD-15) 1×Stereo (3.5mm)
Output Port	1×HDBaseT (RJ45)
Baud Rate	Up to 115200bps
Power Supply	48V PoH or 12V/3A DC (US/EU standards, CE/FCC/UL certified)
ESD Protection	Human Body Model: ±12kV (Air Discharge) ±8kV (Contact Discharge)
Dimensions	46mm×104mm×67mm (W×H×D) [Case Only] 46mm×104mm×71.5mm (W×H×D) [All Inclusive]
Weight	200g
Chassis Material	Aluminum
Silkscreen Color	White
Operating Temperature	0°C–40°C/32°F–104°F
Storage Temperature	-20°C–60°C/-4°F–140°F
Relative Humidity	20–90% RH (Non-condensing)
Power Consumption	20.4W

8.2 Technical Specifications (Receiver)

Input Port	1×Cat.5e/6/7
Output Port	1×HDMI
Pass-through Ports	1×RS-232 [9-pin D-sub] 1×LAN [RJ45]
Supported Resolutions	480i@60Hz - 4K@60Hz (4:2:0, 8-bit) VGA@60Hz - WUXGA@60Hz (RB)
HDMI Cable Length	10m (1080p@60Hz, 12-bit) 5m (4K@60Hz, 4:4:4, 8-bit)
CAT5e/6 Cable Length	100m (1080p@60Hz, 12-bit) 70m (4K@60Hz, 4:2:0, 8-bit)
IR Frequency	30 - 50kHz (30 - 60kHz under ideal conditions)
Baud Rate	Up to 115200bps
Power Supply	48V/0.83A DC (US/EU standards, CE/FCC/UL certified)
ESD Protection	Human Body Model: ±8kV (Air Discharge) ±4kV (Contact Discharge)
Dimensions	128mm×25mm×108mm (W×H×D) [Case Only] 128mm×25mm×117mm (W×H×D) [All Inclusive]

8.3 Video Specifications

Supported PC Resolution (Hz)	HDMI Input	VGA Input	HDBaseT Output
640×480@60/72/75/85	✓	✓	✓
720×400@70	✓	✓	✓
800×600@56/60/72/75/85	✓	✓	✓
1024×768@60/70/75/85	✓	✓	✓
1152×864@75	✓	✓	✓
1280×768@60/60 (RB)	✓	✓	✓
1280×800@60/60 (RB)/75	✓	✓	✓
1280×960@60	✓	✓	✓
1280×1024@60/75/85	✓	✓	✓
1366×768@60/60 (RB)	✓	✓	✓
1440×900@60/60 (RB)	✓	✓	✓
1600×1200@60	✓	✓	✓
1680×1050@60/60 (RB)	✓	✓	✓
1920×1200@60 (RB)	✓	✓	✓

Supported TV Resolution (Hz)	HDMI Input	VGA Input	HDBaseT Output
720×480p@60	✓	×	✓
720×576p@50	✓	×	✓
1280×720p@50/60	✓	×	✓
1920×1080i@50/60	✓	×	✓
1920×1080p@24/25/30/50/60	✓	×	✓
3840×2160p@24/25/30	✓	×	✓
4096×2160p@24/25/30	✓	×	✓
3840×2160p@50/60 (4:2:0)	✓	×	✓
4096×2160p@50/60 (4:2:0)	✓	×	✓

Supported TV Resolution (Hz)	HDMI Input	VGA Input	HDBaseT Output
3840×2160p@50/60	✓	×	×
4096×2160p@50/60	✓	×	×

8.4 Audio Specifications

Analog Input	
Max Audio Level	2Vrms
Impedance	10kΩ
Type	Unbalanced

8.5 Cable Specifications

HDMI Cable Length	1080p		4K
	8-bit	12-bit	8-bit
Input	15m	10m	5m
Output	15m	10m	5m

Cat. Cable Length	1080p	4K
Cat.5e	100m	70m
Cat.6	100m	70m
Cat.7	100m	100m

- **Full HD Video (1080p)**
 - Up to 1080p@60Hz, 12-bit color
 - Data rates lower than 5.3Gbps or below 225MHz TMDS clock
- **Ultra HD Video (4K)**
 - 4K@24/25/30Hz & 4K@50/60Hz (YUV 4:2:0), 8-bit color
 - Data rates higher than 5.3Gbps or above 225MHz TMDS clock



8.5 HDBaseT Features

HDBaseT Feature	Supported
Video & Audio	✓
IR Pass-through	x
RS-232 Pass-through	x
Accept power from Receiver	✓
Send power to Receiver	x
LAN Pass-through	x

9. ACRONYMS

ACRONYM	COMPLETE TERM
Cat.5e	Category 5 (enhanced) cable
Cat.6	Category 6 cable
Cat.7	Category 7 cable
CEC	Consumer Electronics Control
DVI	Digital Visual Interface
HD	High-Definition
HDCP	High-bandwidth Digital Content Protection
HDMI	High-Definition Multimedia Interface
HDR	High Dynamic Range
HDTV	High-Definition Television
LED	Light-Emitting Diode
LPCM	Linear Pulse-Code Modulation
PC	Personal Computer
PD	Powered Device
PoH	Power over HDBaseT
PSE	Power Sourcing Equipment
UHD	Ultra-High-Definition
UHDTV	Ultra-High-Definition Television
USB	Universal Serial Bus
VGA	Video Graphics Array
WUXGA (RB)	Widescreen Ultra Extended Graphics Array (Reduced Blanking)



80 Little Falls Rd, Fairfield, NJ 07004

Phone: 1-800-526-0242

www.comprehensiveco.com

sales@comprehensiveco.com