

INSTALLATION MANUAL – Indoor 24" Wall/Ceiling Adjustable Head Mount

Unpacking

Unpack carefully. This is mechanical equipment and should be handled with care. If an item appears to have been damaged in shipment, replace it properly in its carton and notify the shipper. If any items are missing, notify the vendor. The shipping carton is the safest container in which the unit may be transported. Save it for possible future use.

Service

If the unit ever needs repair service, the customer should contact the vendor for a return materials authorization (RMA) and shipping instructions.

Care and Maintenance

Perform routine maintenance to keep the unit dust free.

Model Designation

2020ANGS Indoor 24" Wall/Ceiling Adjustable Head Mount

Description

The 2020ANGS can be attached to the RLS-2020 Laser Scan Detector allowing the detector to be adjusted for angled detection up to 45 degrees. The adjustable head mount easily secures to the RLS-2020 and has a 24" pole. Mounting hardware included.

Certification

Scanner installation should be performed by a licensed professional and conform to the National Electrical Code (NEC) and any applicable local codes.

Installation

1. Hold mount up to installation surface; use mount holes as a template to mark hole locations.
2. Drill appropriate size hole for fasteners; each fastener should have a 300-lbs pull-out strength.
3. Run cables through mount leaving enough slack to run cable through mount to RLS-2020. Remove adapter plate if needed to route cable through plate. Replace plate.
4. Attach mount to wall using fasteners appropriate for the installation surface. Ensure each fastener has a minimum 300-lbs pull-out strength.
5. Make wiring connections to the RLS-2020 per instructions included with the unit.
6. Attach RLS-2020 to adapter plate per instructions included with the unit.
7. Adjust orientation of upper and lower adjustment brackets as needed and tighten fasteners to secure.
8. Rotate lower adjustment bracket to desired position.
9. Tighten set screw on locking collar using the Allen wrench provided to prevent rotation (see Figure 2).

Figure 1 – 2020ANGS

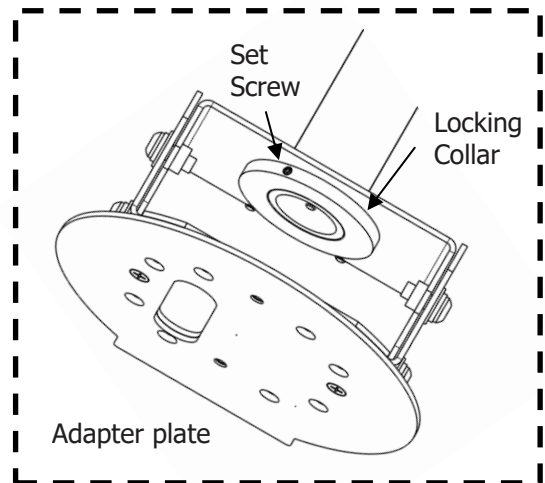
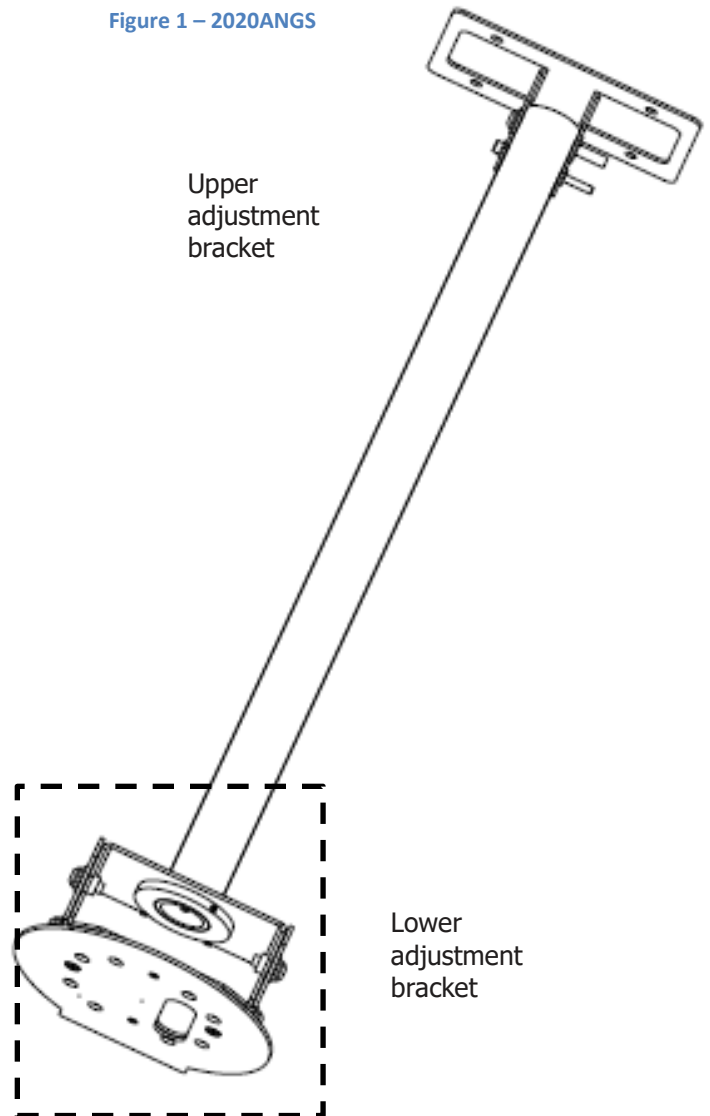

Figure 2 – Locking Collar