



► Model 225XST and 225XST-I

# Electraray® Hazardous Location Strobe Warning Light



Model 225XST is a hazardous location warning light has a black polyurethane coated base and the inner fresnel lens is available in six colors. The clear polycarbonate outer dome can be quickly removed for easy access to inspect the unit or change the lamp.

The 24VDC 225XST-I features a voltage in-rush limiting PCB design that provides greater compatibility with factory automation control systems and less electrical interference with in-rush sensitive devices.

Model 225XST is ideal for wet, corrosive atmospheres like those found in food processing industries, or anywhere a visual signal is needed.

## FEATURES

- 12-24VDC, 24VDC, 120VAC and 240VAC
- Six dome colors: Amber, Blue, Clear, Green, Magenta and Red
- 10,000 hour, high-intensity strobe tube
- 1/2-inch NPT pipe mount
- Indoor/outdoor use
- Type 4X, IP66, IP69K enclosure (Dome up orientation)
- UL and cUL Listed for Class I, Division 2, Groups A, B, C and D; Class II, Division 2, Groups F and G; and Class III.
- CSA Certified

MODEL	VOLTAGE	OPERATING CURRENT	FLASH RATE/ MINUTE	LIGHT OUTPUT		MOUNT
				PEAK <sup>1</sup>	ECP <sup>2</sup>	
<b>225XST-012-024 *</b>	12-24VDC	1.70-0.70 amps	80	580,000 cd	240 cd	1/2" NPT Pipe
<b>225XST-I-024 *</b>	24VDC	0.70 amps (2.0 amp In-rush)	80	580,000 cd	240 cd	1/2" NPT Pipe
<b>225XST-120 *</b>	120VAC	0.25 amps	80	580,000 cd	240 cd	1/2" NPT Pipe
<b>225XST-240 *</b>	240VAC	0.20 amps	80	580,000 cd	240 cd	1/2" NPT Pipe

\* Indicates color: (A) Amber, (B) Blue, (C) Clear, (G) Green (M) Magenta or (R) Red

<sup>1</sup> Peak candela is the maximum light intensity generated by a flashing light during its light pulse

<sup>2</sup> ECP (Effective Candela) is the intensity that would appear to an observer if the light were burning steadily

### HAZARDOUS LOCATION RATING: 225XST and 225XST-I

T-CODE AT MAXIMUM AMBIENT TEMPERATURE, 40°C

Hazardous Location	UL	CSA
Class I, Division 2, Groups A, B, C, D	T2A	T3A
Class II, Division 2, Groups F, G	T5	T3A
Class III	T5	T3A

# Electrarray® Hazardous Location Warning Light (225XST/ 225XST-I)

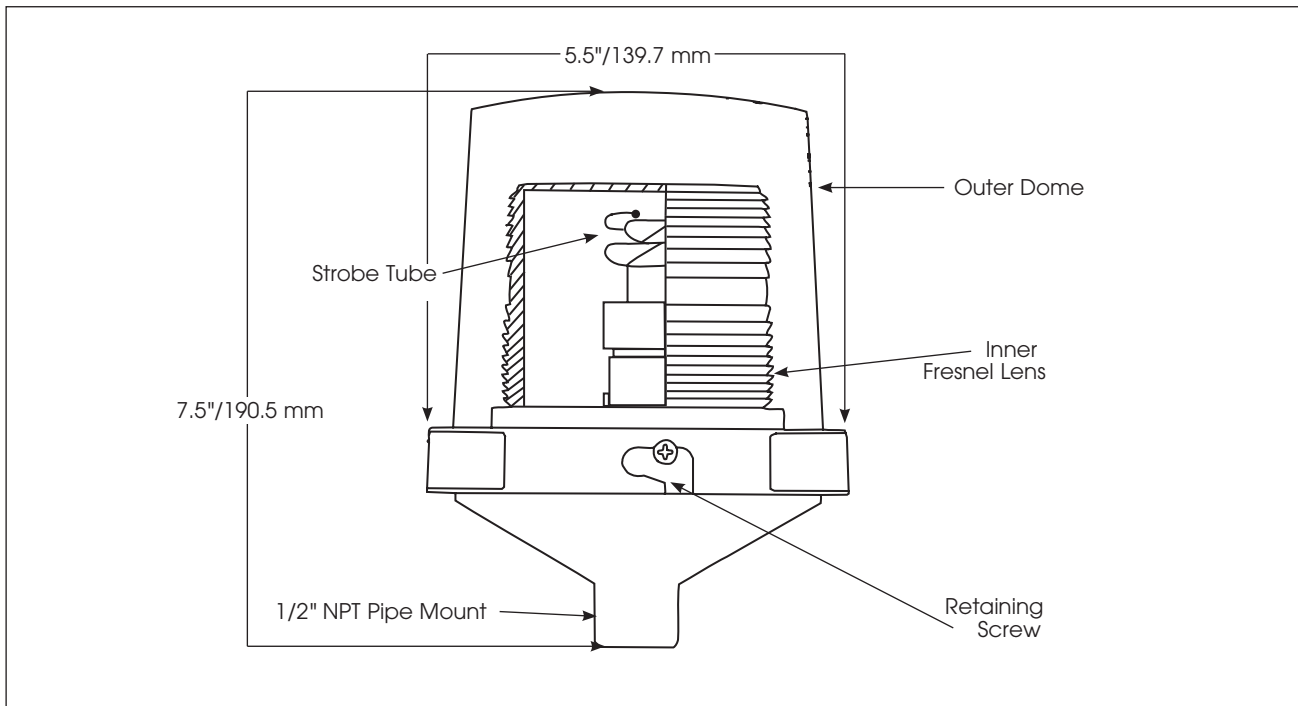

## SPECIFICATIONS

Lamp Life:	10,000 Hours	
Light Source:	Strobe tube	
Operating Temperature:	-40°F to 104°F	-40°C to 40°C
Net Weight:	1.5 lbs	0.68 kg
Shipping Weight:	2.0 lbs	0.91 kg
Height:	7.5"	190.5 mm
Diameter:	5.5"	139.7 mm

## REPLACEMENT PARTS

Description	Part Number
Interior Lens, Amber	K8550C095A-02
Interior Lens, Blue	K8550C095A-01
Interior Lens, Clear	K8550C095A
Interior Lens, Green	K8550C095A-04
Interior Lens, Magenta	K8550C095A-07
Interior Lens, Red	K8550C095A-03
Exterior Dome, Clear*	K8444D219C-04
PC Assembly, 120VAC	K2001905A
PC Assembly, 240VAC	K2001905A-01
Strobe Tube	K8107177A

\*Includes 1 dome gasket

## HOW TO ORDER

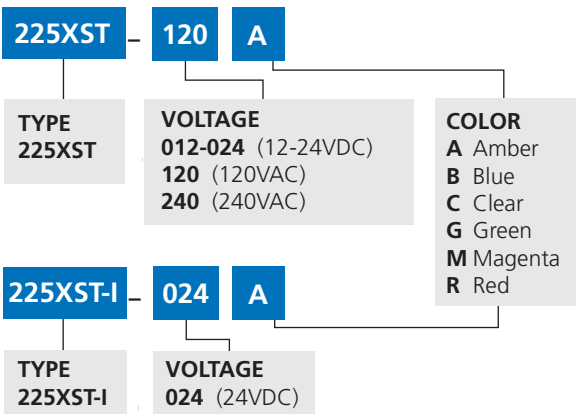

## OPTIONAL ACCESSORIES

Description	Part Number
Hazardous Location Mounting Bracket	LHWB

Mounting Brackets shown on pages 136-137