

UNINTERRUPTIBLE POWER SUPPLY KIT

PSH600-UPS

Kit Consisting of Enclosed Power Control Center Model PSH2RB10 (10 Amp Switch / Circuit Breaker, Two (2) 120 Vac Outlets, Terminals, 120 Vac Input) with a 600 VA UPS. **(No Status Contacts)**

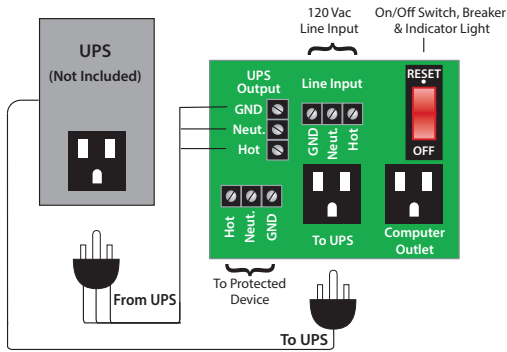

Shown Without Cover



SPECIFICATIONS

UPS

- UPS:** 600VA
- Backup Time:** 2.5 Min. @ Full 600 VA Load
10 Min. @ 1/2 Load
- Power Consumption:** Up to 3 Amp @120 Vac
- Max Load:** 330 Watt
- Frequency:** 50/60 Hz
- Temperature Rating of UPS:** 32 to 104° F
- UPS Transfer Time:** 6ms
- Approvals:** UL Listed, UL1778

PSH2RB10

- Operating Temperature:** -30 to 140° F
- Humidity Range:** 5 to 95% (noncondensing)
- Main Breaker ON/OFF:** Switch / Breaker (10 Amp)
- Approvals:** UL Listed, UL916, C-UL, CE, RoHS
- Dimensions:** 12.000" x 14.000" x 6.000"
Metal Housing with Screw Cover

Notes:

- To order without UPS, so that any other commercial UPS with appropriate ratings and within housing space limitations may be used, see model PSH2RB10.
- To order interface board for replacement or for separate use, order model PSMN2RB10.
- **Average battery life: 3-5 years depending on the number of discharge cycles and environmental temperature**
- UPS may change based on quality and availability

ESTIMATED BACKUP TIME VS. LOAD

