

Tensioned Cosmopolitan Electrol

The Tensioned Cosmopolitan® Electrol® is a ceiling or wall mounted electric screen. A variety of finishes and veneer options are available.

Features

- In-the-roller motor mounting system
- Smooth Roll Technology to keep your screen perfectly flat
- Tensioning Cable System to prevent warping and ensure even lateral tension
- Decora-style, three-position wall switch
- Standard black backing retains projected brightness on front projection surfaces
- Seamless surfaces
- Optional floating mounting bracket allows screen to be mounted onto wall or ceiling studs and aligned left or right after installation (veneer can be added to bracket to match case)
- Available with built-in low voltage control, or Video Projector Interface (screen trigger) or silent motor or low voltage control with silent motor
- A ceiling trim kit is available that enables this screen to be easily recessed into a drop ceiling
- Standard white powder-coated finish ; available in black or veneer upon request
- Slim-Tab, a lower profile, stronger tab design to keep your screen perfectly taut

Optional Accessories:

- Floating Mounting Bracket for Cosmopolitan and Tensioned Cosmopolitan Electrol
- Ceiling Trim Kit for Cosmopolitan Electrol
- Single Motor Low Voltage Control System
- Radio Frequency Wireless Remote Single Motor LVC
- Infrared Wireless Remote Single Motor LVC
- SCB-100
- Video Projector Interface
- Key Operated, 110 Volt Switch
- Locking Switch Cover Plate
- Dual Motor Low Voltage Control System
- Radio Frequency Wireless Remote - Dual Motor LVC
- Infrared Wireless Remote Dual Motor LVC
- Red Laser Pointers
- Green Laser Pointers
- RF PowerPoint Remote with Green Laser Pointer



16:9 HDTV Format

Viewing Area (H x W)		Nominal Diagonal		Overall Case Length	
in.	cm	in.	cm	in.	cm
45" x 80"	114 x 203	92"	234	98½"	250
52" x 92"	132 x 234	106"	269	111"	282
54" x 96"	137 x 244	110"	279	115½"	293
58" x 104"	147 x 264	119"	302	124"	315
65" x 116"	165 x 295	133"	338	137"	348
78" x 139"	198 x 353	159"	404	162"	411

16:10 Wide Format

Viewing Area (H x W)		Nominal Diagonal		Overall Case Length	
in.	cm	in.	cm	in.	cm
50" x 80"	127 x 203	94"	239	99"	251
57½" x 92"	146 x 234	109"	277	112"	284
60" x 96"	152 x 244	113"	287	116½"	296
69" x 110"	175 x 279	130"	330	131½"	334
72½" x 116"	184 x 295	137"	348	138"	351

4:3 Video Format

Viewing Area (H x W)		Nominal Diagonal		Overall Case Length	
in.	cm	in.	cm	in.	cm
43" x 57"	109 x 145	72"	183	75"	191
50" x 67"	127 x 170	84"	213	86"	218
60" x 80"	152 x 203	100"	254	100"	254
69" x 92"	175 x 234	120"	305	114"	290
87" x 116"	221 x 295	150"	381	141"	358

Available with the Following Screen Surfaces



Da-Mat

Half Angle: 60° Gain: 1.0



High Contrast Da-Mat

Half Angle: 45° Gain: 0.8



Cinema Vision

Half Angle: 45° Gain: 1.3



High Contrast Cinema Vision

Half Angle: 50° Gain: 1.1

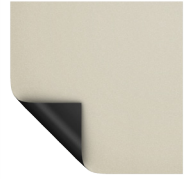

Pearlescent

Half Angle: 40° Gain: 1.5



HD Progressive 1.1 Perf

Half Angle: 85° Gain: 1.1



Dual Vision

Half Angle: 65° Gain: 0.9

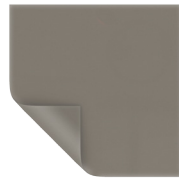

Da-Tex

Half Angle: 30° Gain: 1.3

Product images

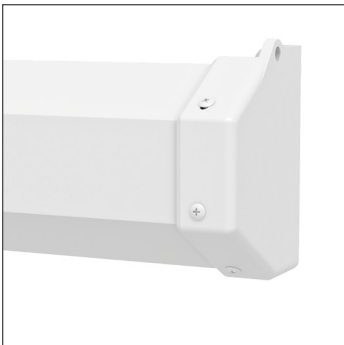

White Case (Standard)

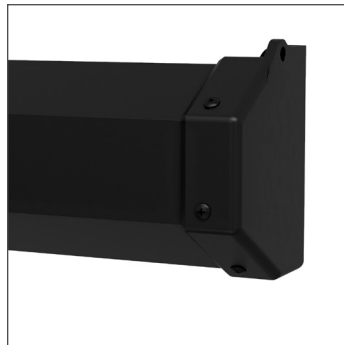

Black Case



Veneer Case

Veneer Finishes

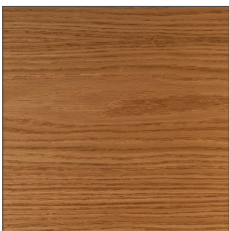

Light Oak Veneer

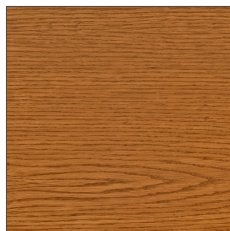

Medium Oak Veneer

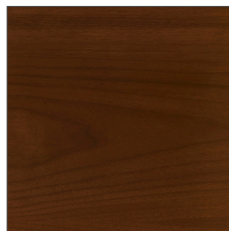

Natural Walnut Veneer

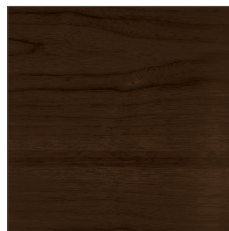

Heritage Walnut Veneer



Cherry Veneer

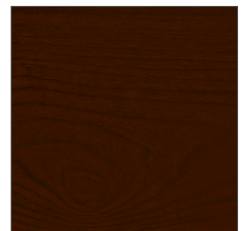

Mahogany Veneer



A BRAND OF MILESTONE AV TECHNOLOGIES | www.milestone.com

P 800.622.3737 / 574.267.8101 F 877.325.4832 / 574.267.7804

E info@da-lite.com

In British Columbia, Milestone AV Technologies ULC carries on business as MAVT Milestone AV Technologies ULC.

©2017 Milestone AV Technologies. DL-0442 (Rev. 3) 0717.

Da-Lite is a registered trademarks of Milestone AV Technologies. All other brand names or marks are used for identification purposes and are trademarks of their respective owners. All patents are protected under existing designations. Other patents pending.