

Assembly Instructions - External Wall Plate

IMPORTANT! Read entire instruction sheet before you start installation and assembly.

*** MAXIMUM LOAD CAPACITY:**
175 lb (79 kg)

Models

WSP 450, WSP 450S, WSP 450W,
WSP 460, WSP 460S,
WSP 470, WSP 470S, WSP 470W

* Refers to maximum weight of TV or max. combined weight of TV, VCR and VCR Bracket.

⚠ WARNING

- Wall or mounting structure must be capable of supporting a minimum static load of 600 lb (272 kg).

WSP 450, WSP 450S, and WSP 450W for studs on 16" (406 mm) centers, contains two electrical box knockouts.

WSP 460 and WSP 460S for studs on 20" (508 mm) centers, contains two electrical box knockouts.

WSP 470, WSP 470S, and WSP 470W for studs on 24" (610 mm) centers, contains two electrical box knockouts.

PARTS LIST

MODEL #			PART #	QTY.	DESCRIPTION
WSP 450	WSP 460	WSP 470			
✓			A 024-1014	1	wall plate 16" centers (black)
	✓		024-1015		wall plate 20" centers (black)
		✓	024-1016		wall plate 24" centers (black)
✓	✓	✓	B 510-9108	8	1/4-20 x 1/2" phillips screw
✓	✓	✓	C 520-9521	12	1/4-20 x 2 1/2" phillips screw
✓	✓	✓	D 590-1093	12	toggler
✓	✓	✓	E 540-9440	8	washer

PARTS LIST

MODEL #			PART #	QTY.	DESCRIPTION
WSP 450S	WSP 460S	WSP 470S			
✓			A 024-4014	1	wall plate 16" centers (silver)
	✓		024-4015		wall plate 20" centers (silver)
		✓	024-4016		wall plate 24" centers (silver)
✓	✓	✓	B 520-9511	8	1/4-20 x 1/2" phillips screw
✓	✓	✓	C 520-9522	12	1/4-20 x 2 1/2" phillips screw
✓	✓	✓	D 590-1093	12	toggler
✓	✓	✓	E 540-9444	8	washer

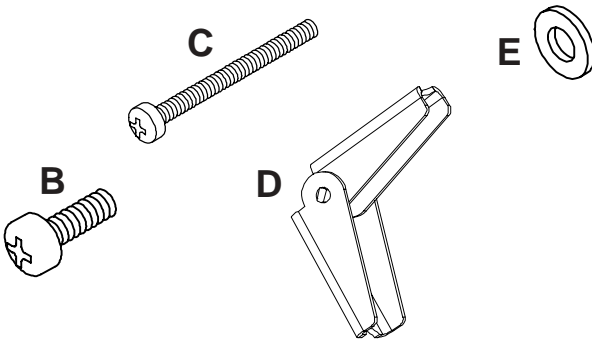

PARTS LIST

MODEL #			PART #	QTY.	DESCRIPTION
WSP 450W	WSP 470W				
✓			A 024-2014	1	wall plate 16" centers (white)
	✓		024-2016		wall plate 24" centers (white)
✓	✓		B 520-9511	8	1/4-20 x 1/2" phillips screw
✓	✓		C 520-9522	12	1/4-20 x 2 1/2" phillips screw
✓	✓		D 590-1093	12	toggler
✓	✓		E 540-9444	8	washer

Knockouts

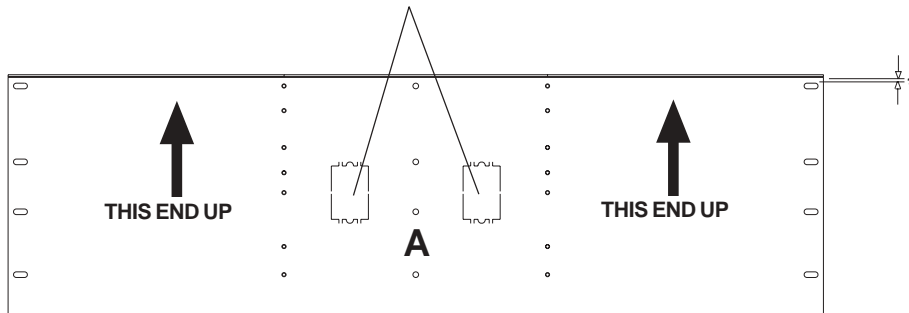

*Note: The mounting hole which is closest to the lip of the plate indicates the up position.

Note: Wall plate may appear slightly different than illustrated.

Note: See below for proper holes to attach mount to wall plate.

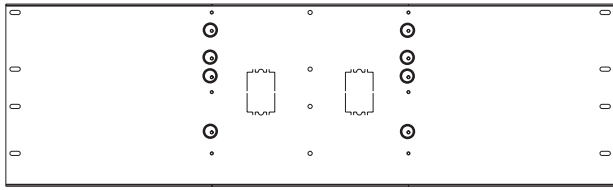

PLA-1

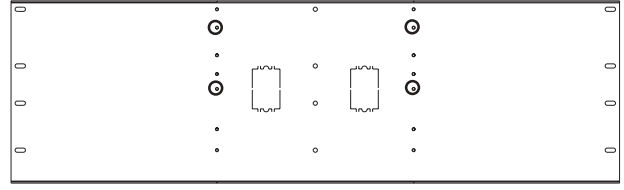

PLA-2

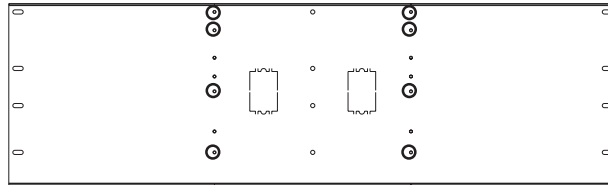

ALL OTHER MOUNTS

1 Use a stud finder to locate stud centers.

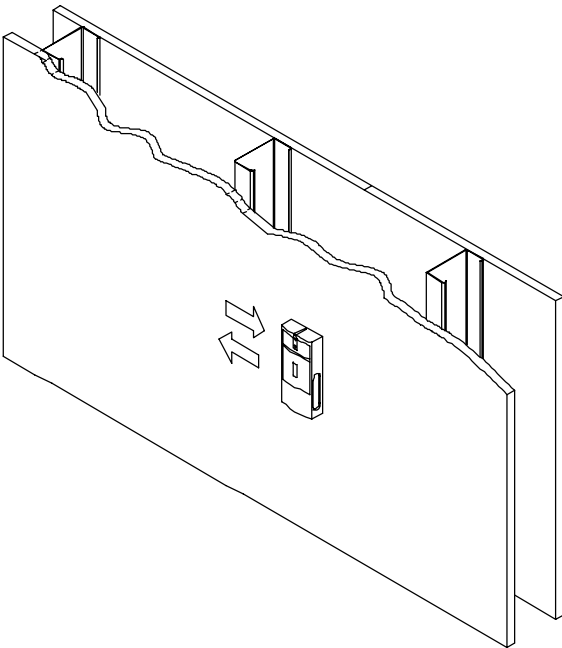

2 Use wall plate (A) as a template to mark slot centers on stud centers.

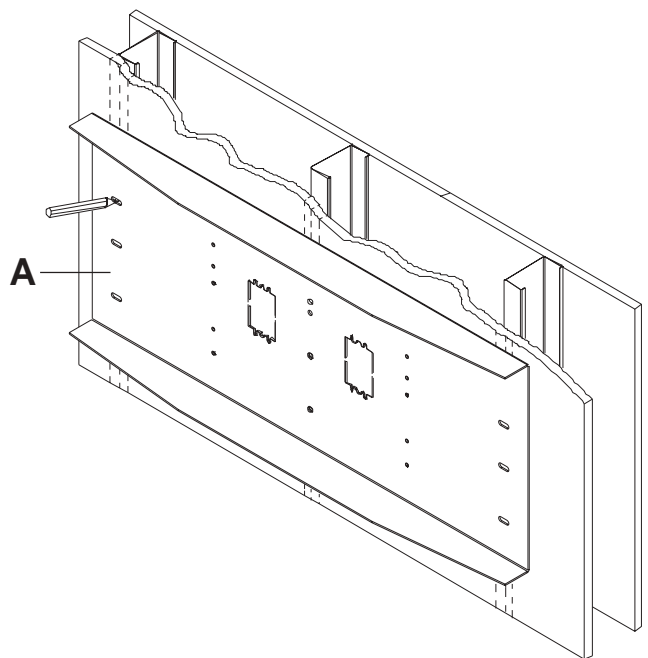

Note: See below for quantity of fasteners and proper holes to attach wall plate to wall.

- 3** Drill 3/4" (19 mm) dia. holes through drywall and studs. Insert togglers (D) as shown below...

Eight 1/4-20 x 1/2" phillips screws (B) and eight washers (E) are provided to attach mount (sold separately) to wall plate.

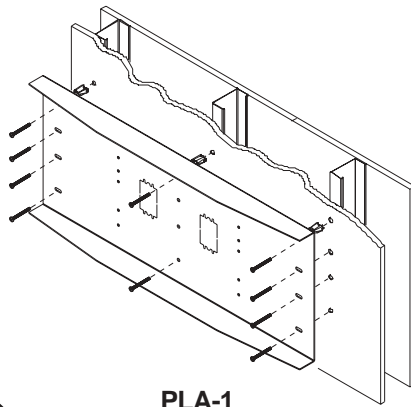
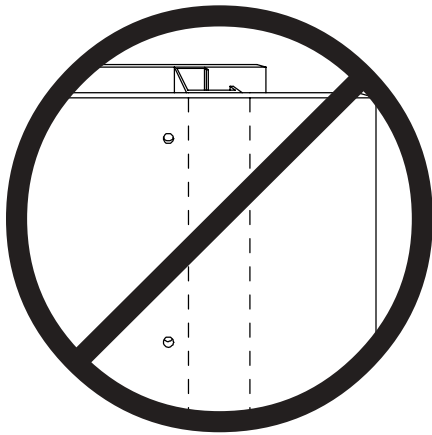

PLA-1

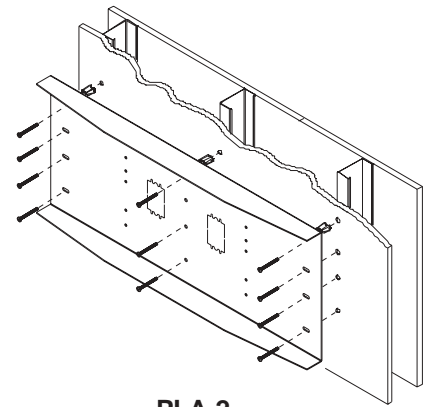

PLA-2

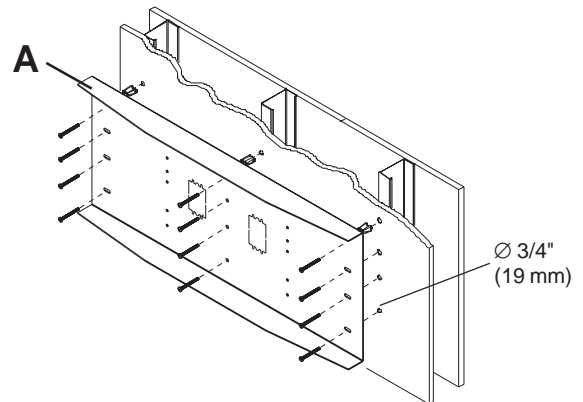

ALL OTHER MOUNTS

⚠ WARNING

- Make sure that mounting screws are anchored into the center of the studs. The use of an "edge to edge" stud finder is highly recommended.

- 3-1** Place screw (C) through wall plate (A). Partially fasten the toggler (D) to the back of the screw. Pivot ends of toggler (D) 90°.

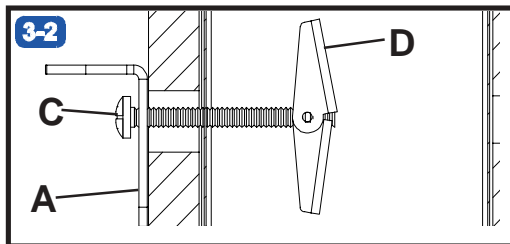
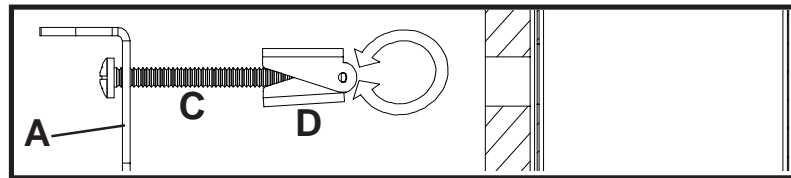

Push toggler (D) through hole. Pull screw (C) back until toggler (D) hits the inside of the metal stud.

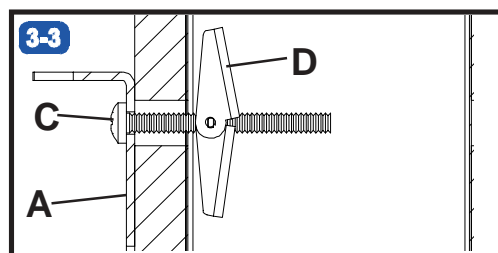

Fasten all twelve screws (C) tight, until wall plate (A) is flush with wall.