



# AH66-8ST

8" 2-Way Stadium Horn System 65° x 65°



AH66-8ST

## Features

- Heavy duty mounting bracket (included) allows for easy installation to most any flat surface
- Three forged eyebolts also included for suspended installation
- 100 watts power handling
- Constant directivity design offers controlled coverage of 65° horizontal by 65° vertical (2kHz octave band)
- Driver compliment includes 8" cast frame woofer with a concentrically mounted 1" exit compression driver coupled to a 65° H x 65°V HF horn
- Easy, weather resistant connection via a convenient recessed terminal block located on the bottom of the loudspeaker
- Includes a built-in, high efficiency 60 watt 70.7V transformer
- Efficiency rating of 100dB (1 W / 1 M)
- Maximum output of 120dB (Rated Power @ 1 M)

## Applications

Atlas Sound model AH66-8ST stadium horn is ideal for directional sound distribution where full range reproduction, maximum intelligibility, and high sound pressure levels are required. Applications include football stadiums, sports arenas, baseball fields, convention centers, and auditoriums.

Weather resistant construction features of the AH66-8ST include a multiple screen configuration to prevent moisture from damaging internal components. A perforated aluminum screen covers the large horn mouth, a secondary screen is in place forward of the high frequency driver, and a third tightly perforated screen protects the 8" cast frame woofer.

## Installation

A heavy-duty stainless steel "C" style mounting bracket is included with the AH66-8ST to allow easy mounting to most any flat surface. Three drop forged eyebolts are also pre-installed (2-front of horn plus 1-rear for "pull-up") for suspension mounting via load rated wire rope. (Use caution when suspending any object overhead. Refer to installation manual for more details).

The AH66-8ST includes a weather resistant 7 pole terminal block connector on the underside of the speaker for ease of hook-up. This terminal block includes connection points for internal 70.7V transformer with taps settings of 7.5, 15, 30, and 60 watts and 8Ω connection for transformer bypass.



AH66-8ST

## Technical Specifications

Power Rating:	100 watts
Sensitivity 1 W / 1 M:	100dB SPL (70Hz to 17kHz 1/3 octave bands)
Frequency Response:	90Hz - 15kHz (±5dB)
Dispersion:	65° x 65°
Impedance:	8Ω Nominal
Transformer Taps:	7.5, 15, 30, and 60 watts
Height:	20.95" (532.13mm)
Width:	17.91" (454.91mm)
Depth:	20.98" (532.89mm)
Shipping Weight:	61 lbs (27.7kg)
Driver Type:	1" HF & 8" LF

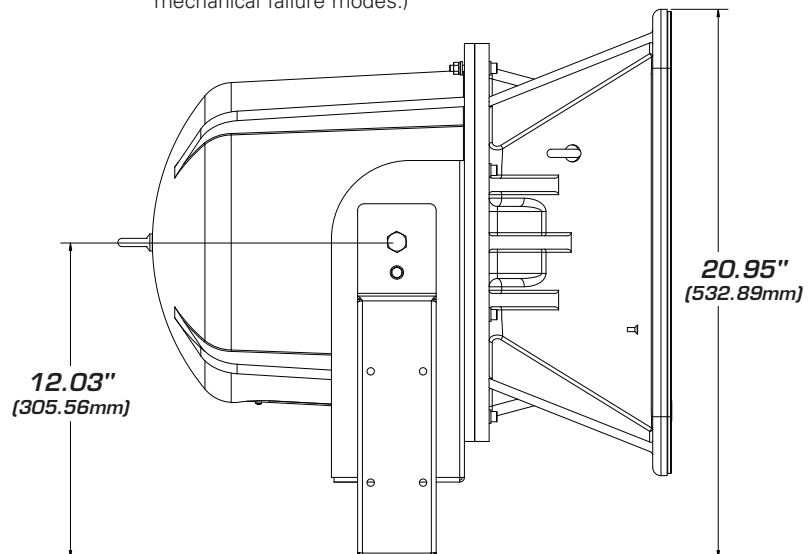
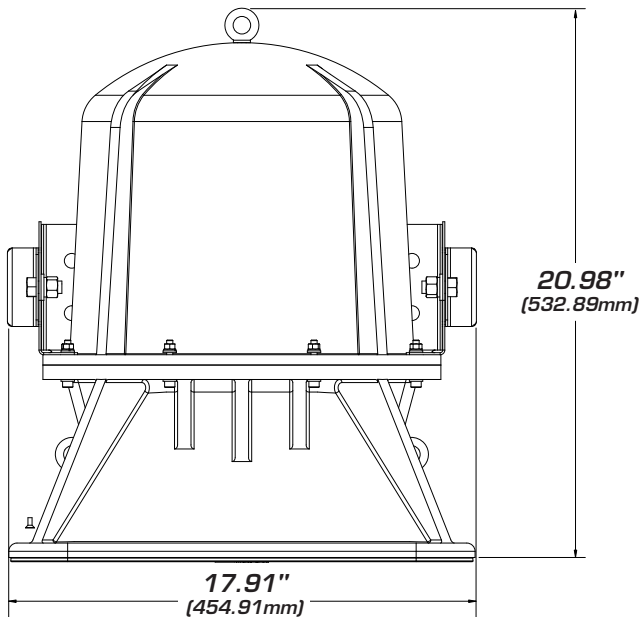
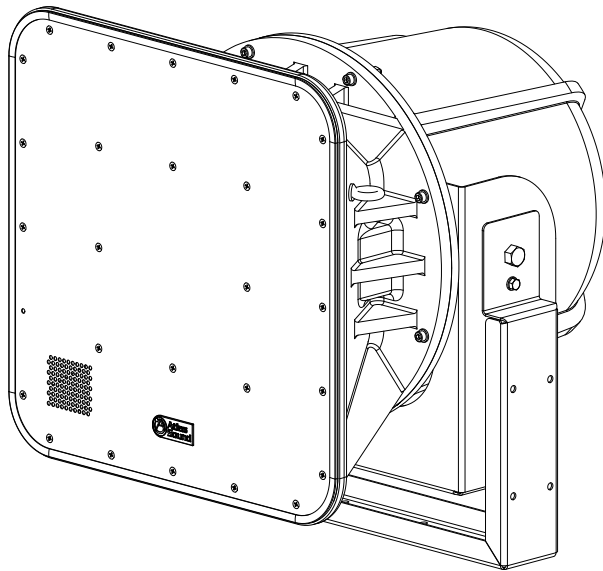

## Architect & Engineer Specifications

Loudspeaker shall be Atlas Sound Model AH66-8ST or approved equal.

The loudspeaker system shall be a horn-loaded, 2-way design with an 8" inch polycone woofer.

The loudspeaker system shall include an 8", horn loaded, cast frame woofer and an integral, concentrically mounted 1" exit compression driver coupled to a constant directivity high frequency horn. The three pole (18dB/octave) dividing network shall have a crossover frequency of 1.8 kHz. The dividing network shall include a poly switch protection circuit for the high-frequency component.

The loudspeaker system shall be capable of providing a sound dispersion angle of 65° horizontal by 65° vertical in the 2kHz octave band.

Rated power shall be 100 watts RMS based on EIA Standard RS-426B.\*

Enclosure shall be UV-resistant, low pressure injection molded fiberglass and shall include a 3 stage multiple mesh filter system for weather and rodent resistance: to include a 20-gauge perforated aluminum screen on front mouth assembly, a 100 x 100 weave stainless steel mesh between HF horn and HF driver and a 100 x 100 weave stainless steel mesh over 8" woofer. The loudspeaker shall include a stamped and formed, 2mm stainless steel powder coated mounting bracket assembly for surface mounting and three M8 drop forged eyebolts for suspension mounting two at the front and one at the rear to allow the speaker system to be suspended and aimed using rated wire rope.

Sensitivity shall be 100dB SPL (90Hz to 15kHz in 1/3 octave bands) measured at a distance of one meter on axis with a one watt input half space (2.83V).

Overall frequency response shall be 90Hz to 15kHz (±5dB).

The input section located on the bottom rear of the loudspeaker shall be via 7 position screw down terminal strip internally configured to allow input to an internally mounted 70.7V transformer with 7.5, 15, 30, & 60 watt taps and a by-pass jumper direct coupled to the Speaker for nominal 8Ω operation. The system connections shall be protected from the elements by a screw affixed weather resistant cover.

Dimensions shall be: Height: 20.95" (532.13mm)  
Width: 17.91" (454.91mm)  
Depth: 20.98" (532.89mm)  
Weight: 61 lbs (27.7kg)

\*EIA test spectrum is applied for eight hours.

(This procedure provides a rigorous test of both thermal and mechanical failure modes.)

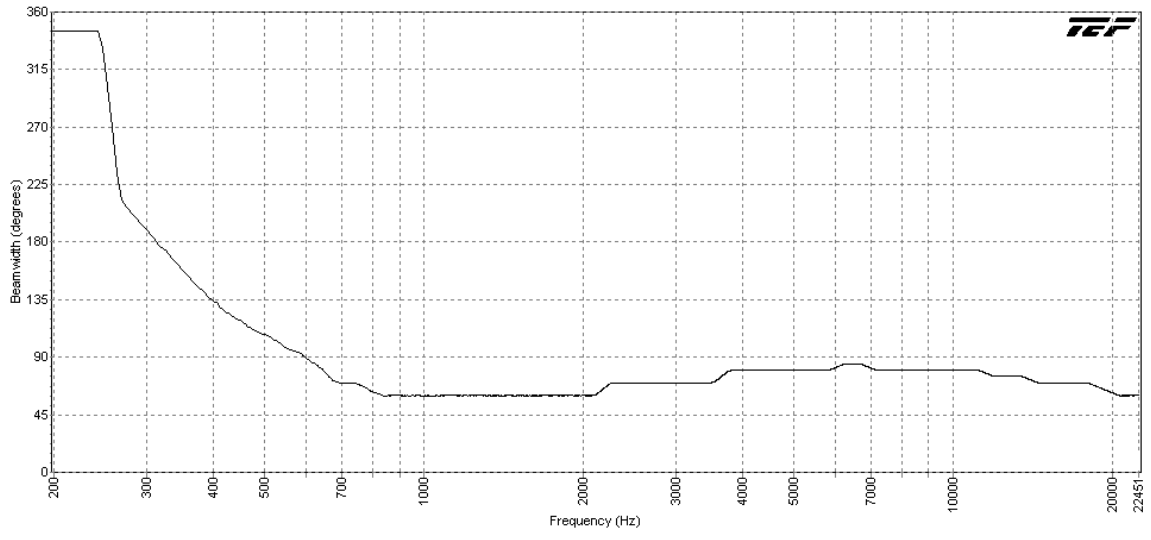

AH66-8ST Horizontal Beamwidth (-6dB)

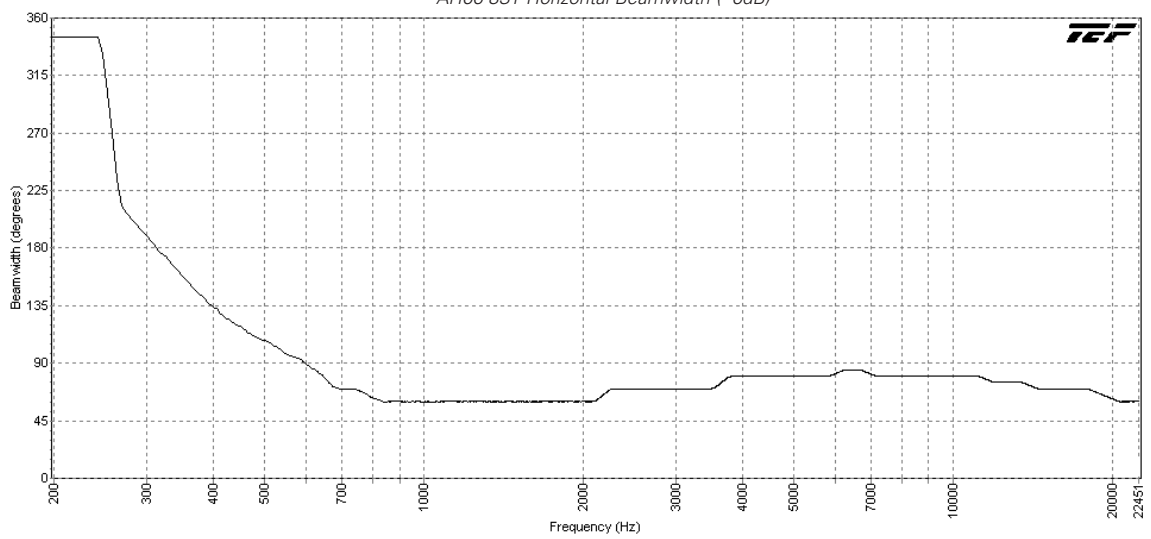

AH66-8ST Vertical Beamwidth (-6dB)

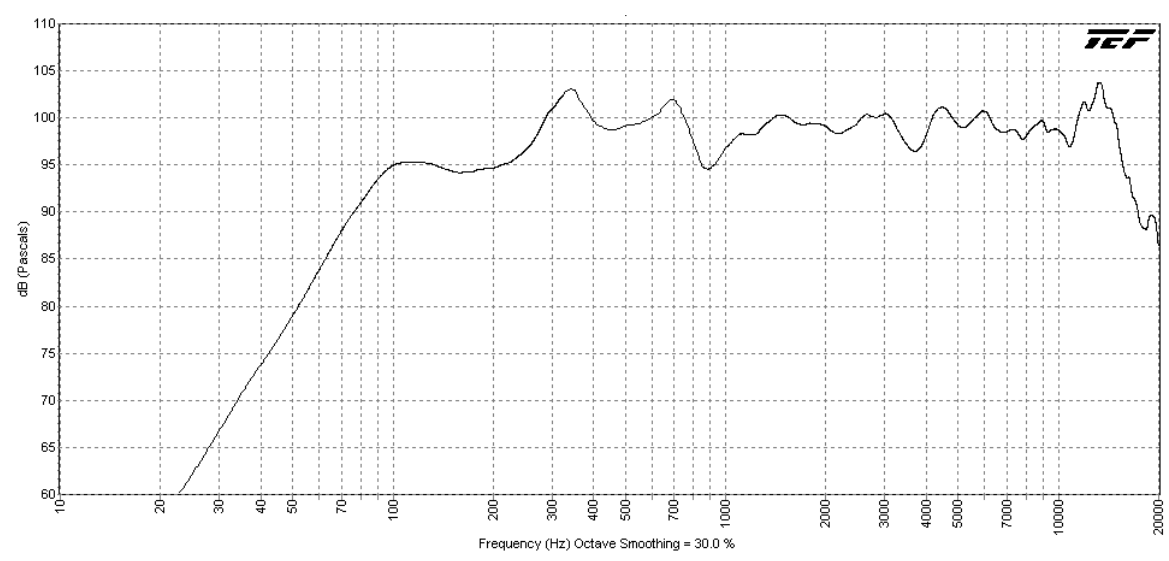

AH66-8ST Frequency Response

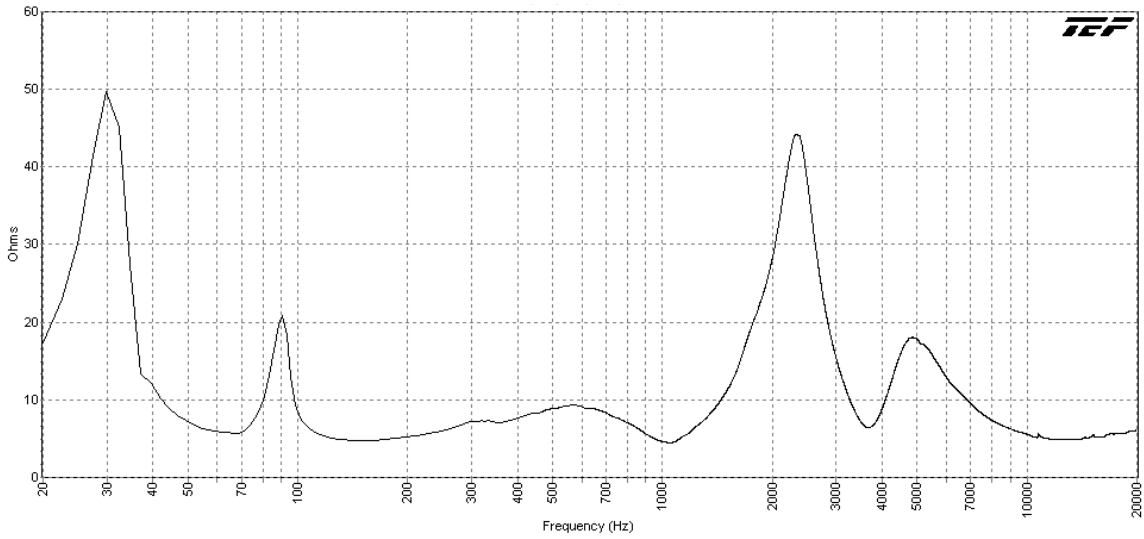

AH66-8ST Impedance (ohms) vs. Frequency

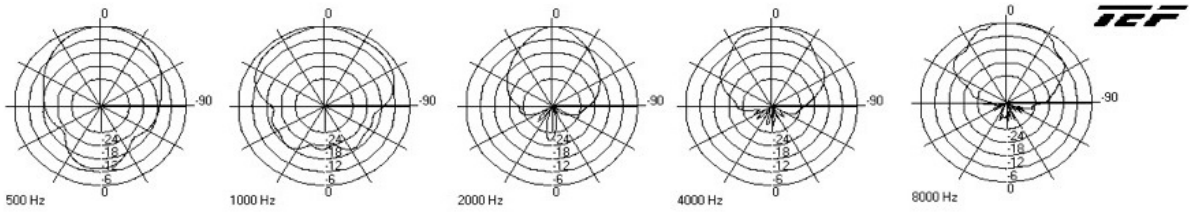

AH66-8ST Polars (Normalized To Zero On Axis) (-6dB)

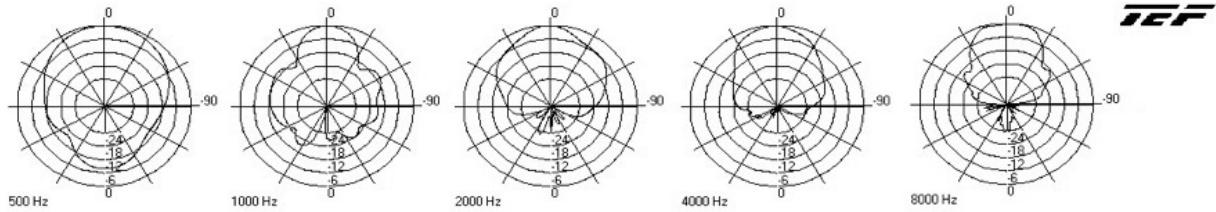

AH66-8ST Polars (Normalized To Zero On Axis) (-6dB)