

GV-CS1320 Camera Access Controller

User's Manual



Before attempting to connect or operate this product, please read these instructions carefully and save this manual for future use.



© 2021 GeoVision, Inc. All rights reserved.

Under the copyright laws, this manual may not be copied, in whole or in part, without the written consent of GeoVision.

Every effort has been made to ensure that the information in this manual is accurate. GeoVision, Inc. makes no expressed or implied warranty of any kind and assumes no responsibility for errors or omissions. No liability is assumed for incidental or consequential damages arising from the use of the information or products contained herein. Features and specifications are subject to change without notice.

GeoVision, Inc.
9F, No. 246, Sec. 1, Neihu Rd.,
Neihu District, Taipei, Taiwan
Tel: +886-2-8797-8377
Fax: +886-2-8797-8335
<http://www.geovision.com.tw>

Trademarks used in this manual: *GeoVision*, the *GeoVision* logo and *GV* series products are trademarks of GeoVision, Inc. *Windows* is the registered trademark of Microsoft Corporation.

October 2021

Scan the following QR codes for product warranty and technical support policy:



[Warranty]



[Technical Support Policy]

Contents

Naming and Definition	vii
Optional Device	vii
Installation Considerations	ix
Chapter 1 Introduction	1
1.1 Key Features	4
1.2 Packing List	6
1.3 System Requirements.....	7
1.4 Physical Description.....	8
1.5 Installation	9
1.5.1 Wire Definition	9
1.5.2 Installing GV-CS1320	10
1.5.3 Replacing the Silica Gel Bag.....	11
1.6 Connecting GV-CS1320	12
1.6.1 Connecting RS485 / OSDP Readers	12
1.6.2 Connecting Network Readers	13
1.6.3 Connecting Input Devices to GV-CS1320	13
1.6.4 Connecting an Output Device to GV-CS1320	14
1.6.5 Connecting GV-CS1320 to PC.....	15
1.6.6 Connecting the Power.....	17
1.7 LED Status and Beeper	18
Chapter 2 Getting Started	19
2.1 Creating Login Credential	20
2.1 Checking the Dynamic IP Address.....	21
2.3 Assigning an IP Address.....	21
Chapter 3 Accessing the Camera Access Controller	23
3.1 Accessing Your Surveillance Images	23
3.2 Functions Featured on the Main Page	25
3.2.1 The Live View Window.....	25
3.2.2 The Control Panel of the Live View Window	27

3.2.3	Snapshot of a Live Video	30
3.2.4	Video Recording	30
3.2.5	Digital PTZ.....	30
3.2.6	Wide Angle Lens Dewarping.....	31
3.2.7	Picture-in-Picture and Picture-and-Picture View.....	32
3.2.8	Alarm Notification.....	34
3.2.9	Video and Audio Configuration	35
3.2.10	Remote Configuration	36
3.2.11	Camera Name Display.....	36
3.2.12	Image Enhancement.....	36

Chapter 4 Administrator Mode37

4.1	Video	38
4.1.1	Video Settings	39
4.1.2	Text Overlay	43
4.2	Access Control.....	44
4.2.1	Basic Setting.....	44
4.2.2	Extended Device.....	52
4.3	Events and Alerts.....	54
4.3.1	RTSP/ONVIF	54
4.4	Network	55
4.4.1	Status	55
4.4.2	LAN	56
4.4.3	Advanced TCP/IP	57
4.4.4	IP Filtering	60
4.4.5	SNMP Setting	61
4.5	Management.....	62
4.5.1	Date and Time Setting	62
4.5.2	Storage Setting	63
4.5.3	User Account	64
4.5.4	Log Information.....	64
4.5.5	Tools.....	65
4.5.6	Language.....	66
4.6	SIP	67

Chapter 5 Advanced Applications69

5.1	Upgrading System Firmware.....	69
-----	--------------------------------	----

5.1.1	Using the Web Interface	70
5.1.2	Using the IP Device Utility.....	71
5.2	Backing Up and Restoring Settings.....	72
5.2.1	Backing Up the Settings.....	72
5.2.2	Restoring the Settings.....	73
5.3	Restoring to Factory Default Settings.....	74
5.4	Verifying Watermark	75
5.4.1	Accessing AVI Files	75
5.4.2	Running Watermark Proof	75
5.4.3	The Watermark Proof Window	76
Chapter 6	GV-DVR / NVR / VMS Configurations	77
6.1	Setting up GV-CS1320 on GV-DVR / NVR	78
6.1.1	Customizing the Basic Settings.....	80
6.2	Setting up GV-CS1320 on GV-VMS.....	82
Chapter 7	Mobile Phone Connection	84
Chapter 8	Connecting to GV-I/O Box 4 Ports	85
8.1	Physical Connection	86
8.2	Setting up GV-CS1320	87
Appendix.	89
A.	RTSP Protocol Support.....	89
B.	The CGI Command.....	89

Naming and Definition

GV-DVR/NVR	GeoVision Analog and Digital Video Recording Software. GV-DVR/NVR also refers to Multicam System , GV-NVR System , GV-Hybrid DVR System and GV-DVR System at the same time.
GV-VMS	GeoVision Video Management System for IP cameras.

Optional Device

Optional devices can expand the capabilities and versatilities of your GV-CS1320. Consult your sales representative for more information.

GV-AS ID Card & GV-AS ID Key Fob	125 KHz and 13.56 MHz cards / key fobs are available.
GV-CR420	GV-CR420 is a 13.56 MHz card reader with a built-in 4MP wide angle IP camera which saves the costs of maintaining a sperate camera for access control.
GV-CR1320	GV-CR1320 is a 13.56 MHz card reader with a built-in 2 MP camera which saves the costs of maintaining a sperate camera for access control. GV-CR1320 also supports VoIP calls, allowing the operator to talk to visitors and entering the access code to open the door.
GV-DFR1352	GV-DFR1352 is a 13.56 MHz card reader. The reader has both Wiegand and RS-485 outputs that can be connected to any standard access control panel.
GV-FR2020	GV-FR2020 is a 13.56 MHz face recognition reader. The reader supports two operation modes for access control: Face Recognition and Card.
GV-FWC	GV-FWC integrates GeoVision face-recognition-based cameras, software and readers into access control systems by sending access card data, paired to Face IDs, to controllers either through TCP/IP or Wiegand connection.
GV-GF Fingerprint Readers	The reader supports three operation modes for access control: Fingerprint Only, Fingerprint + Card and Card Only. Readers with optical and capacitance sensors are available.
GV-IB25 / 65 / 85 Infrared Button	GV-IB25 / 65 / 85 Infrared Button detects infrared movement within 3 to 12 cm and allows you to open the door with a wave of hand.

GV-IO Box Series	GV-IO Box series provides 4 / 8 / 16 inputs and relay outputs, and supports both DC and AC output voltages, with optional support for Ethernet module and 4E additionally supporting PoE connection.
GV-RK1352	GV-RK1352 is a 13.56 MHz card reader with keypad. The reader has both Wiegand and RS-485 outputs that can be connected to any standard access control panel.
GV-R1352	GV-R1352 is a 13.56 MHz card reader. The reader has both Wiegand and RS-485 outputs that can be connected to any standard access control panel.
GV-WTR	GV-WTR is a converter designed for converting Wiegand interface to RS-485 interface, and vice versa. It enables 3rd party readers to be connected to RS-485 GV-Controllers, as well as allowing GV-AI FR (software) and GV-CR1320 (RS-485 camera reader) to be connected to 3rd-party Wiegand controllers.
Electric Lock	Three types of electric locks are available: electromagnetic lock, electric bolt and electric strike.
Power Adapter	Contact our sales representatives for the countries and areas supported.
Push Button Switch	The push button switch can be integrated with access control system, allowing door exit by momentarily activating or deactivating the electric locking device. Both American standard and European standard push buttons are available.

Installation Considerations

To make sure the finger and face of the cardholder can be detected, follow the instructions below to set up GV-CS1320.

Touchpad Recognition:

- The touchpad cannot be activated with gloves on.



Installation Height:

- When placed at a building gate, GV-CS1320 should be about 1.4-1.5 meters above the ground.
- When placed at a parking lot gate, GV-CS1320 should be about 1.2 meters above the ground to match the height of vehicles.

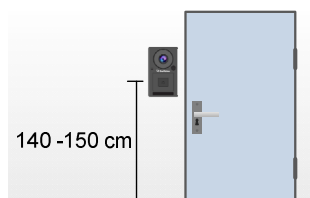

Face Detection Limitations

- GV-CS1320 cannot detect the face of cardholders wearing facial masks or sunglasses.
- GV-CS1320 is designed to detect front-view faces only. If the face is slightly tilted horizontally or vertically, the tilt angle cannot exceed 15° degree.

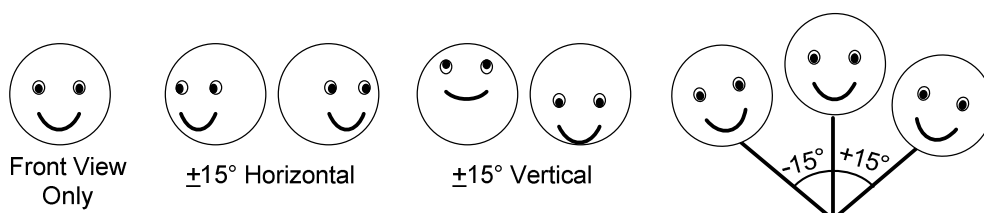

Lighting Conditions

- Avoid placing GV-CS1320 where the light source is directly behind the subject.
- Prevent light from directly falling onto GV-CS1320's camera lens.

Chapter 1 Introduction



GV-CS1320 is an access controller with a built-in 2 MP camera and 13.56 MHz reader. GV-CS1320 recognizes identification cards and grants access to up to 100,000 users accordingly. Its camera captures the live view of entrance and transmits it to the access control system GV-ASManager over a network, without the need of installing and maintaining a separate camera in addition to the camera access controller.

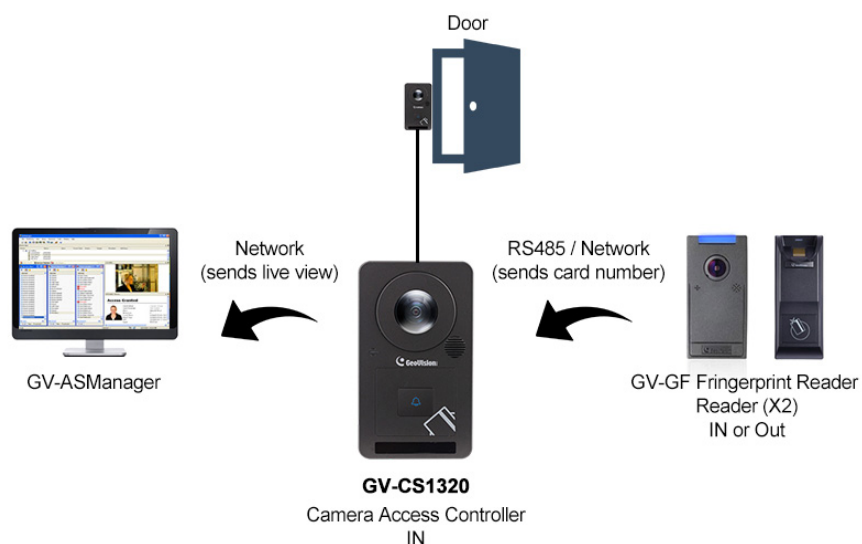

Figure 1-1

Three types of notifications are available for the operator to communicate with visitors at the door installed with GV-CS1320 and grant access: SIP/VoIP Calling, GV-ASNotify PC program and GV-Access mobile app.

1. GV-ASNotify PC Program:

Visitors requesting entry permits can use the touchpad on GV-CS1320 to be granted access. When GV-CS1320 is connected to GV-ASManager over a network, GV-ASNotify will generate a notification message whenever the touchpad is activated. The operator can use GV-ASNotify to watch live view and talk to the surveillance site.

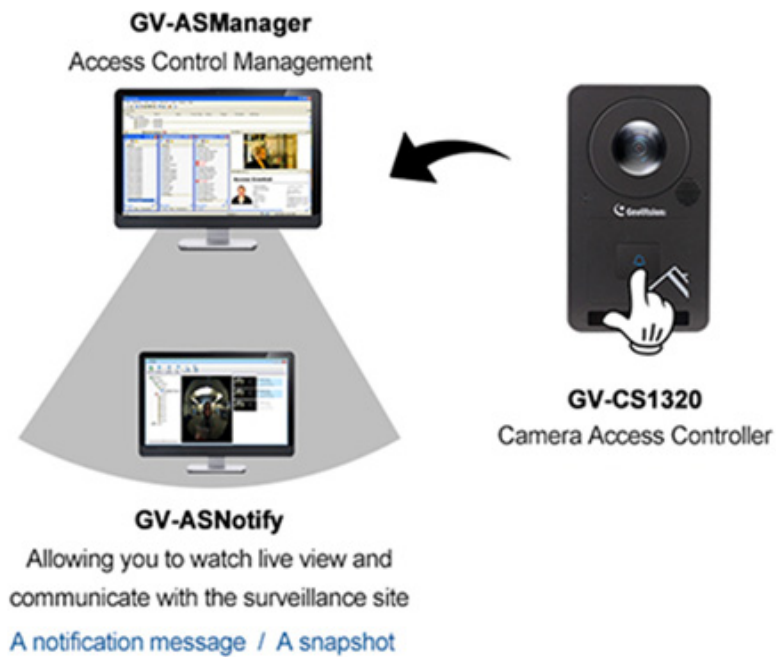

Figure 1-2

2. GV-Access Mobile App:

Similarly, the operator can launch mobile app GV-Access to enable live view and voice communication with visitors at the door before permitting entry. The operator will receive an alert notification upon the trigger of the touchpad. For details, find the App from our [website](#).

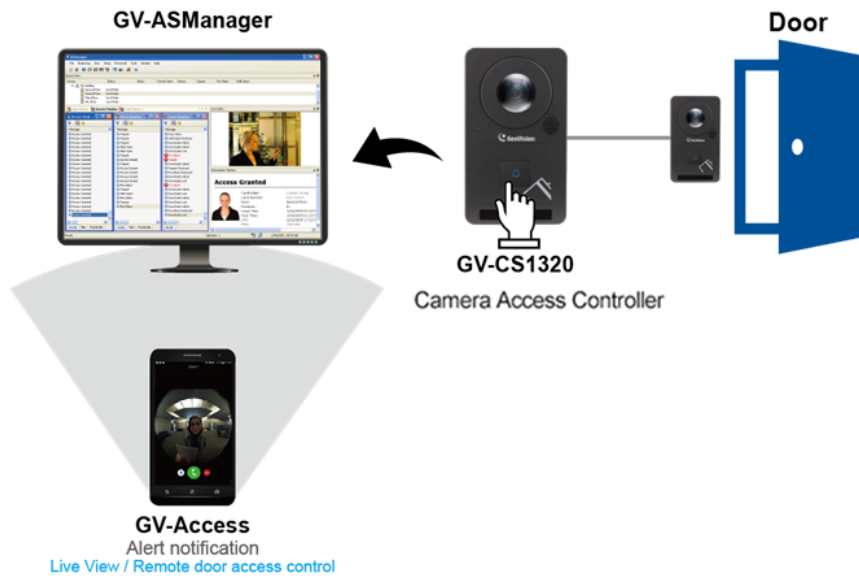

Figure 1-3

3. VoIP Calls:

When the touchpad is activated, GV-CS1320 will place a call to the operator through VoIP. The operator can then communicate with the visitor and enter an access code to open the door.

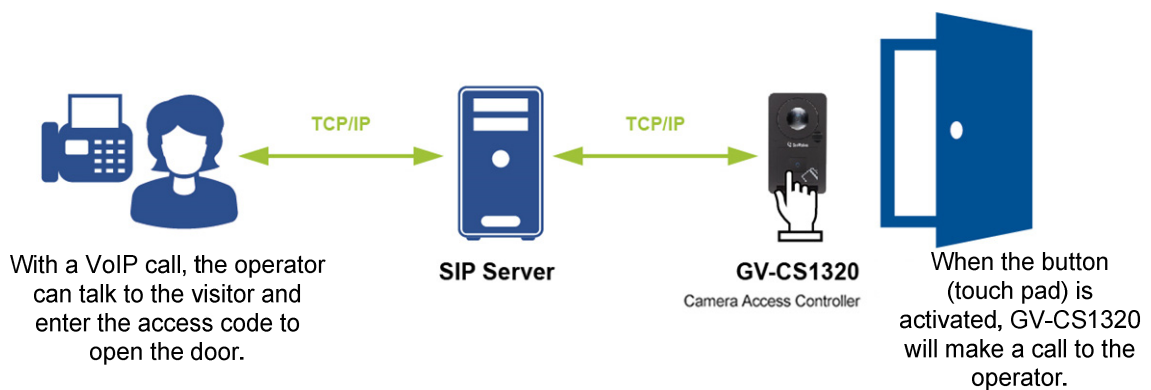

Figure 1-4

1.1 Key Features

Camera

- 2 MP progressive scan super low lux CMOS
- Minimum illumination at 0.02 lux
- Dual streams from H.264 and MJPEG
- Up to 15 fps at 1920 x 1080
- Day and night function (with removable IR-cut filter)
- Built-in IR with effective distance up to 3 m (10 ft)
- Ingress protection (IP66)
- 12V DC, 2.5A / PoE+ (IEEE 802.3at)
- Built-in microphone and speaker
- Wide Dynamic Range (WDR)
- Built-in micro SD card slot
- Provides 180° panorama view
- ONVIF (Profile S) conformant

Reader

- Built-in 13.56 MHz reader (Mifare DESFire, Mifare Plus and Mifare Classic)
- Support for GV-Proximity Cards with GID (GeoVision identifier) to enhance security
- Access by card plus face detection
- Up to 2 readers of RS-485, OSDP and network communication

Access Control

- 1 door (one-way or two-way control)
- 2 inputs, dry contact (Door Sensor / Exit Button)
- 1 relay output (Electric Lock)
- Support for GV-I/O Box 4 Ports for door / fire / temper sensor, door button and doorbell applications
- Touchpad to activate two-way communication between the operator and visitors
- Snapshots captured upon card presented and touchpad activated
- SIP / VoIP calling support
- Anti-passback (APB) support
- Different access control modes enabled according to the Authentication Schedule: Card only mode (default), Card and Face Mode
- GV-Access app for push notifications

1.2 Packing List

- GV-CS1320



- Mounting Plate



- Standard Screw x 2



- Plastic Screw Anchor x 2



- Security Screw



- Torx Wrench



- Silica Gel Bag
- Software DVD
- Micro SD Card 2 GB (formatted and installed)
- Warranty Card

1.3 System Requirements

To access the functions and settings of GV-CS1320 on the Web interface, ensure your PC has good network connection and use one of the following web browsers:

- Internet Explorer 9 x or later
- Microsoft Edge
- Google Chrome
- Firefox

Note: For users of non-IE browsers, download **GV-Web Viewer** to access full functioning user interface. See *3.1 Accessing Your Surveillance Images*.

Compatible Software Versions

The GeoVision software versions compatible with GV-CS1320 are listed below.

- **GV-VMS:** V15.10 or later
- **GV-DVR / NVR:** V8.6.2.0 (with Patch) or later
- **GV-Control Center:** V3.3.0.0 (with Patch) or later
- **GV-Redundant Serer / Failover Server:** V1.1.0.0 (with Patch) or later
- **GV-Recording Server:** V1.2.5.0 (with Patch) or later
- **GV-Edge Recording Manager:** V1.1.0.0 (with Patch) or later

The compatible versions between GV-CS1320 and GV-ASManager:

GV-CS1320	V1.0	V1.10	V1.11	V2.00	V2.11	V2.20
GV-ASManager	V4.3.5.0	V4.3.5.0 V4.4.0.0	V4.4.2.0 V4.4.3.0	V5.0.0.0	V5.0.1.0	V5.0.2.0
GV-CS1320	V3.00	V3.01 ~ V3.03	V3.04 ~ V3.05	V3.06	V3.07~ V3.08	V3.09
GV-ASManager	V5.1.1	V5.2.0	V5.3.0	V5.3.1	V5.3.2	V5.3.3
GV-CS1320	V3.10					
GV-ASManager	V5.3.4					

1.4 Physical Description

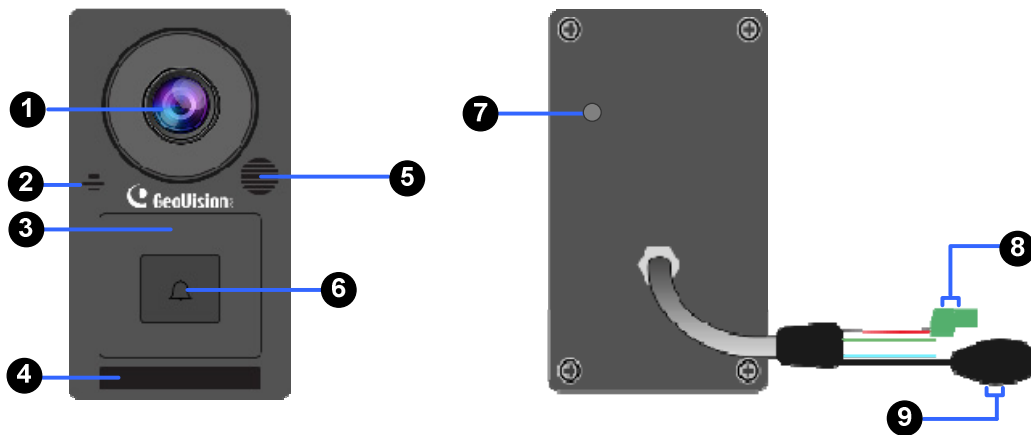

Figure 1-5

No.	Name	Function
1	Lens	Receives image.
2	Microphone	Receives sound from GV-CS1320.
3	Card Reader	Reads ID cards or ID tags.
4	IR LEDs	Automatically illuminates for night time use.
5	Speaker	Talks to the surveillance area from the local computer.
6	Touchpad and LED status	Touch to activate the talk mode. See <i>1.7 LED Status and Beeper</i> .
7	Default Button	Resets all configurations to default factory settings. See <i>5.3 Restoring to Factory Default Settings</i> .
8	Power Cable	Connects to power supply. See <i>1.6.5 Connecting the Power</i> .
9	Ethernet Port	Connects to network and power supply. See <i>1.6.4 Connecting GV-CS1320 to PC</i> .

1.5 Installation

1.5.1 Wire Definition

The wire assignment of GV-CS1320 cable data is illustrated below.

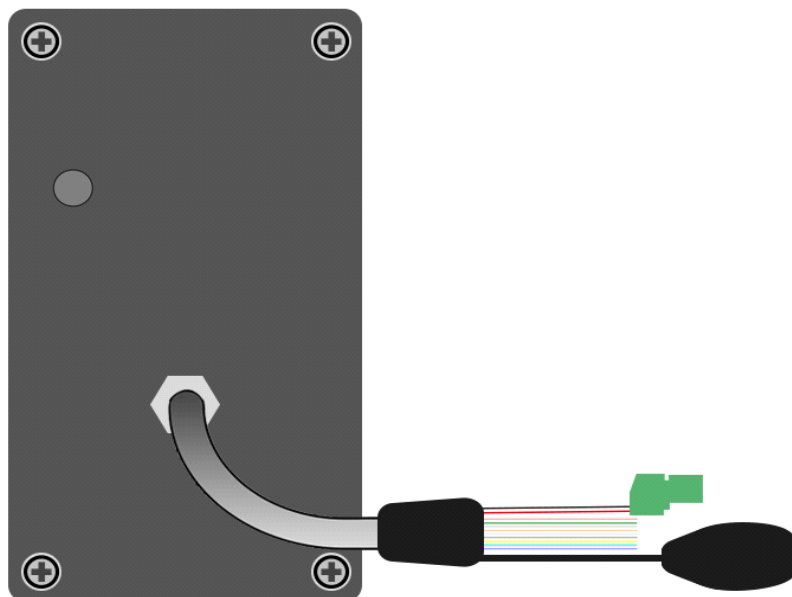

Figure 1-6

Wire	Definition	Wire	Definition
RJ-45	Ethernet	Blue	RS-485 +
Red	12V DC	Light Blue	RS-485 -
Black	GND	Gray	Door NO
Yellow	Sensor IN1	Purple	Door COM
Brown	IN COM	Orange	Door NC
Light Red	Button IN2	Green	Not functional
White	Not functional		

1.5.2 Installing GV-CS1320

After the location of GV-CS1320 is decided, follow the steps below to install the camera access controller.

Note: You will need to prepare a single gang power box for wall mount installation.

1. Attach the single gang power box to the wall.
2. Place the mounting plate on the single gang power box and secure with the 2 standard screws provided.
3. Place GV-CS1320 on the mounting plate together with the single gang power box and thread the cables through the holes.
4. Secure the security screw on the bottom with the mounting plate.

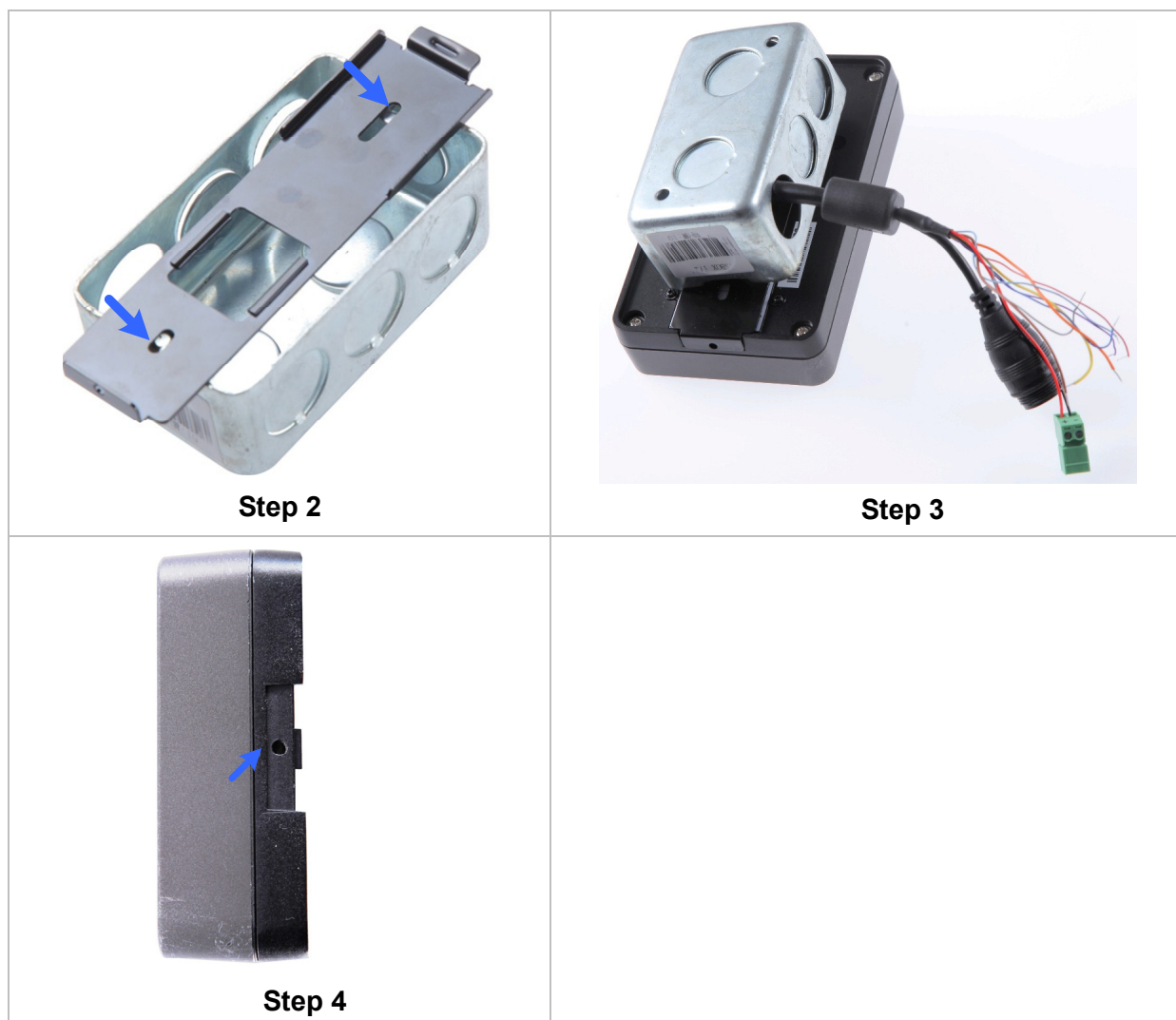

Figure 1-7

1.5.3 Replacing the Silica Gel Bag

If you opened the compartment cover at the back of your GV-CS1320 to change a new Micro SD card, you must follow the steps below to replace the original silica gel bag with a new one.

1. Open the compartment cover at the back of your GV-CS1320 with a screwdriver.

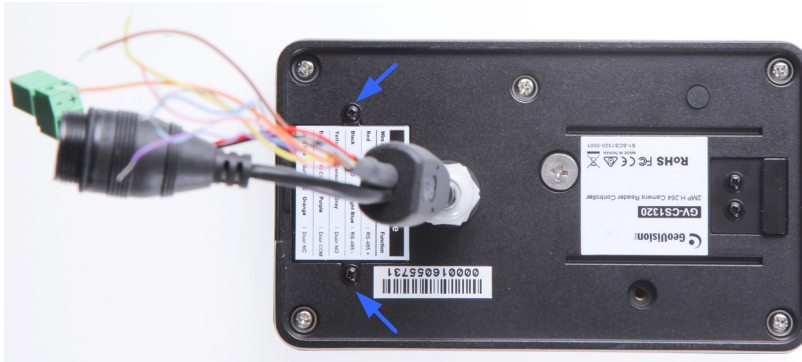

Figure 1-8

2. To replace the silica gel bag, remove the silica gel bag and place a new one to the camera.



Figure 1-9

3. Fasten the compartment cover.

IMPORTANT:

1. The silica gel loses its effectiveness when the dry camera access controller is opened. To prevent the lens from fogging up, replace the silica gel bag every time when you open the camera access controller and conceal the gel bag in the camera access controller within two minutes of exposing to the open air.
 2. For each newly replaced silica gel bag, allow it to absorb moisture for at least 30 minutes before operating the camera.
-

1.6 Connecting GV-CS1320

1.6.1 Connecting RS485 / OSDP Readers

GV-CS1320 can establish RS-485 connection with up to 2 RS-485 or OSDP readers. Connect the RS-485 wires from GV-CS1320 to the reader. The 12V DC and GND wires of GV-CS1320 are used to power the reader, but you will need to set up a separate power source if the total power consumption (including output devices) exceeds 12V.

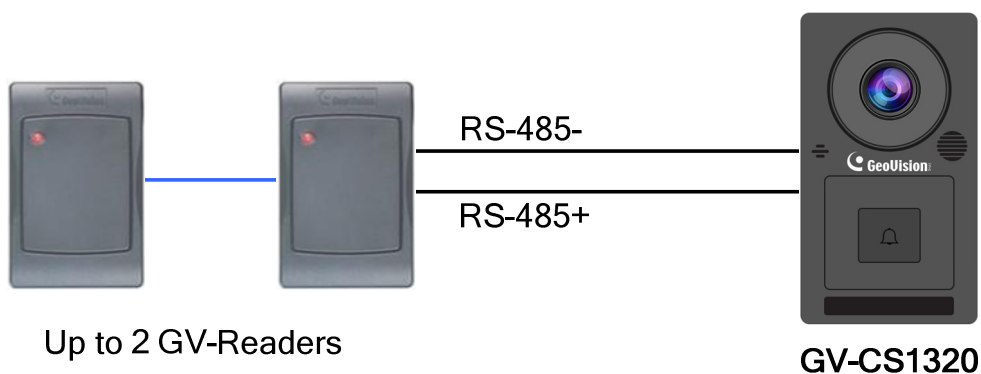

Figure 1-10

The table below shows the wire assignments of RS485 connection on GV-CS1320.

Wire color	Definition
Red	12V DC
Black	GND
Blue	RS-485 +
Light Blue	RS-485 -

Note: GV-CS1320 supports either RS-485 or OSDP communication, but not both at the same time.

1.6.2 Connecting Network Readers

GV-CS1320 supports network connection with GV-CR420, GV-GF1921 / 1922 and GV-FR2020.

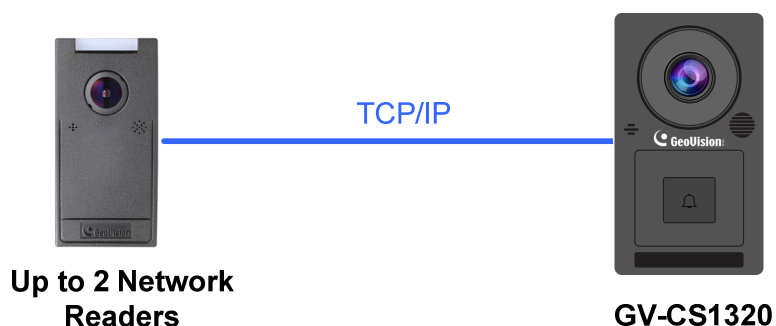

Figure 1-11

1.6.3 Connecting Input Devices to GV-CS1320

GV-CS1320 supports 2 types of inputs:

1. Sensor inputs, e.g. door status sensor
2. Button inputs, e.g. door opener and exit button

All inputs are **dry contact** and can be configured as normally open (NO) or normally closed (NC) through the GV-CS1320 Web interface. The default value is **NO**. To change the input status, see *4.2.1.4 Input Setting*

The table below shows the wire assignments of input connectors on GV-CS1320.

Wire color	Definition
Yellow	Sensor IN1
Light Red	Button IN2
Brown	IN COM

Note: You can connect a GV-I/O Box to your GV-CS1320 to give an extra layer of security. For details, see *Chapter 8 Connecting to GV-I/O Box 4 Ports*.

1.6.4 Connecting an Output Device to GV-CS1320

GV-CS1320 supports 1 type of output: Door outputs, e.g. electronic lock.

The table below shows the wire assignments of output connectors on GV-CS1320.

Wire color	Definition
Purple	Door COM
Orange	Door NC
Gray	Door NO

Check if your output device meets the following absolute maximum ratings before connecting it to the Door outputs.

Breakdown Voltage	250V AC, 220V DC
Continuous Load Current	1A (30V DC), 0.3A (125V AC)

Note:

1. Absolute Maximum Ratings are those values beyond which damage to GV-CS1320 circuit board may occur. Continuous operation of GV-CS1320 at the absolute rating level may affect GV-CS1320's reliability.
2. You can connect a GV-I/O Box to your GV-CS1320 to give an extra layer of security. For details, see *Chapter 8 Connecting to GV-I/O Box 4 Ports*.

To connect an output device:

The example below illustrates the connection of a locking device to GV-CS1320. Connect the (+) point on the locking device to the Door COM wire on GV-CS1320, connect the two (-) points of the locking device and the external power supply together, and connect the (+) point on the external power supply to the Door NO or Door NC wire on GV-CS1320 based on the state of the locking device.

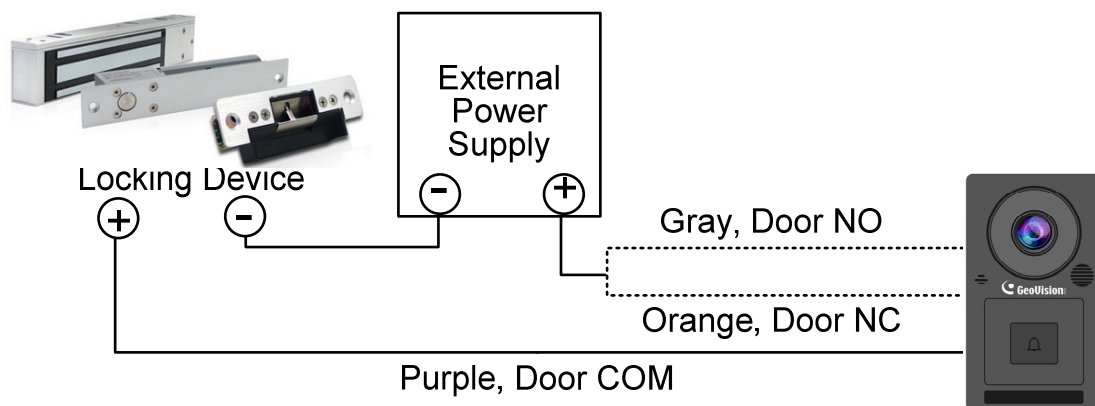

Figure 1-12

1.6.5 Connecting GV-CS1320 to PC

Connecting GV-CS1320 to a computer enables you to access its Web interface and connect it to GV-ASManager if the computer is installed with GV-ASManager. The computer running GV-ASManager software can be used to monitor the access information and alarm messages from GV-CS1320. The communication link between the computer and GV-CS1320 requires a network connection.

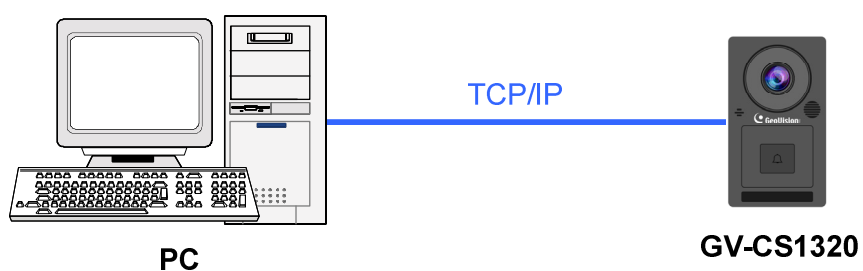

Figure 1-13

When GV-CS1320 is connected to GV-ASManager, GV-ASNotify will generate a notification message and snapshot whenever the touchpad on GV-CS1320 is activated. You can use GV-ASNotify to watch live view and talk with the surveillance site. For details, see Chapter 16, *GV-ASNotify* in *GV-ASManager User's Manual*.

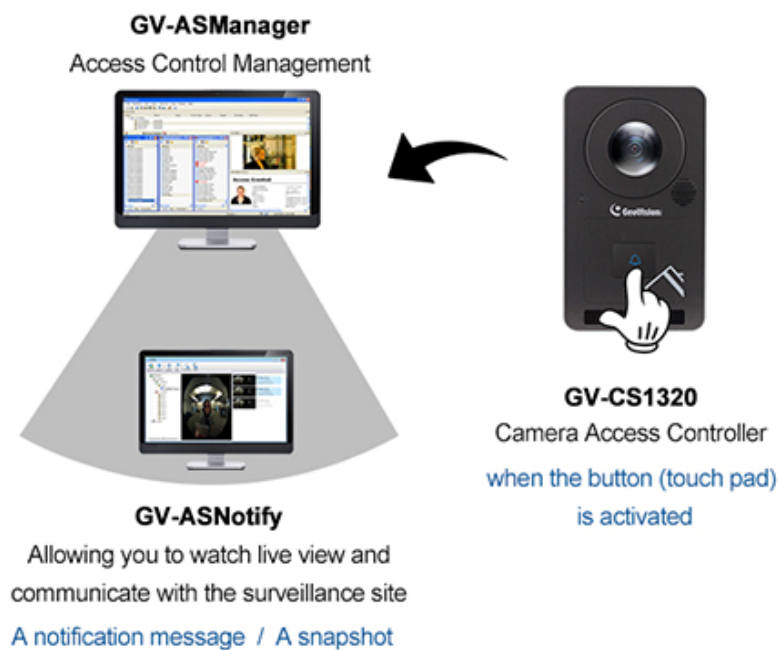

Figure 1-14

Note:

1. GV-CS1320 is only compatible with GV-ASManager V4.3.5.0 or later.
 2. While GV-CS1320 is performing a power reset, duplicate messages may be displayed in the System Event Log on GV-ASManager.
-

1.6.6 Connecting the Power

You can choose to supply power using a power adapter or using a Power over Ethernet (PoE) adapter.

- When using a Power Adaptor, connect 12V and GND wires to a 12V, 3A power adapter and then connect the power adapter to a power source.

The table below shows the pin assignments of the power connectors on GV-CS1320.

Wire color	GV-CS1320 Definition
Red	12V DC
Black	GND

- When using PoE adapter, power will be provided to the device through the Ethernet cable.

Note:

1. Power should only be applied to the unit when all connections are completed and tested.
 2. GV-CS1320 produces an output voltage of 12V. You will need to connect an external power supply if the total power consumption exceeds 12V after readers and output devices are connected.
-

1.7 LED Status and Beeper

Normally, the LED on GV-CS1320 is blue during standby mode and the LED flashes green when a card is granted access. The LED status and beeper under different conditions are listed below

Condition	LED	Beeper
Ready	Blue (Connected to GV-ASManager) Purple (Disconnected from GV-ASManager)	N/A
Access Denied	Displays red LED momentarily	Two short beeps
Access Granted	Displays green LED momentarily	One long beep
Touchpad activated	Flashes blue momentarily	One short beep
Touchpad ignored	Returns to blue/purple LED	Three short beeps after 30 seconds
Talk mode enabled	Constant yellow	N/A
Note: Talk mode is two-way communication, enabled by GV-Access app, VoIP calls or GV-ASNotify application.		

Chapter 2 Getting Started

This chapter provides basic information to get GV-CS1320 on the network.

Follow the steps below to get GV-CS1320 working on the network:

1. Use a standard network cable to connect the camera access controller to your network.
2. Connect power using one of the methods:
 - Using the power adapter, connect to power. For details, see *1.6.5 Connecting the Power*.
 - Use the Power over Ethernet (PoE) function. The power will be provided over the network cable.
3. You can now access the Web interface of GV-CS1320.
 - If GV-CS1320 is installed in a LAN with the DHCP server, use GV-IP Device Utility to look up its dynamic IP address. See *2.2 Checking the Dynamic IP Address*.
 - If GV-CS1320 is installed in a LAN without the DHCP server, the default IP address **192.168.0.10** will be applied. You also can assign a different static IP. See *2.3 Assigning an IP Address*.

Once GV-CS1320 is properly installed, refer to the sections below for some of the important features that can be configured through its Web interface:

- **Date and time adjustment:** see *4.5.1 Date and Time Settings*.
- **Login and privileged passwords:** see *4.5.2 User Account*.
- **Network gateway:** see *4.4 Network*.
- **Camera image adjustment:** see *3.2.2 The Control Panel of the Live View Window*.
- **Video format, resolution and frame rate:** see *4.1.1 Video Settings*.

2.1 Creating Login Credentials

When purchasing a new GV-CS1320 or after loading default, you need to set up a login username and password for GV-CS1320.

1. Download and install GV-IP Device Utility from our [website](#).
2. On the GV-IP Device Utility window, click  to search for your GV-CS1320.
3. Double-click your GV-CS1320 in the GV-IP Device Utility list. This dialog box appears.

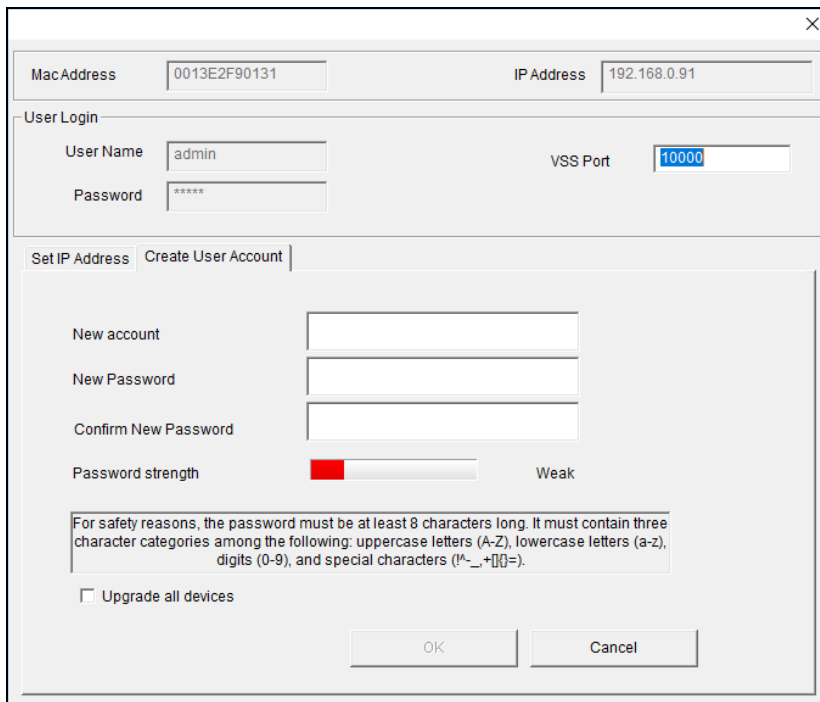

The screenshot shows a dialog box titled "GV-IP Device Utility" with a close button (X) in the top right corner. At the top, there are two input fields: "Mac Address" with the value "0013E2F90131" and "IP Address" with the value "192.168.0.91". Below these is a section titled "User Login" containing "User Name" (admin), "Password" (masked with asterisks), and "VSS Port" (10000). The main area has two tabs: "Set IP Address" and "Create User Account". The "Create User Account" tab is active, showing three input fields for "New account", "New Password", and "Confirm New Password". Below these is a "Password strength" indicator with a red bar and the word "Weak". A text box contains the password requirements: "For safety reasons, the password must be at least 8 characters long. It must contain three character categories among the following: uppercase letters (A-Z), lowercase letters (a-z), digits (0-9), and special characters (!@_+[]=-)." At the bottom left is a checkbox labeled "Upgrade all devices". At the bottom right are "OK" and "Cancel" buttons.

Figure 2-1

4. Click the **Create User Account** tab to type a new username and password. Note that the new password must meet the password strength requirements.
5. Optionally, click **Upgrade all devices** to use the same username and password on all other devices of the same model.

2.2 Checking the Dynamic IP Address

Follow the steps below to look up the IP address and access the Web interface.

Note: The PC installed with GV-IP Device Utility must be under the same LAN as GV-CS1320.

1. Download and install GV-IP Device Utility from our [website](#).
2. On the GV-IP Utility window, click the  button to search for the IP devices connected in the same LAN. Click the **Name** or **Mac Address** column to sort.
3. Find GV-CS1320 with its MAC address, click on its IP address and select **Web Page**.

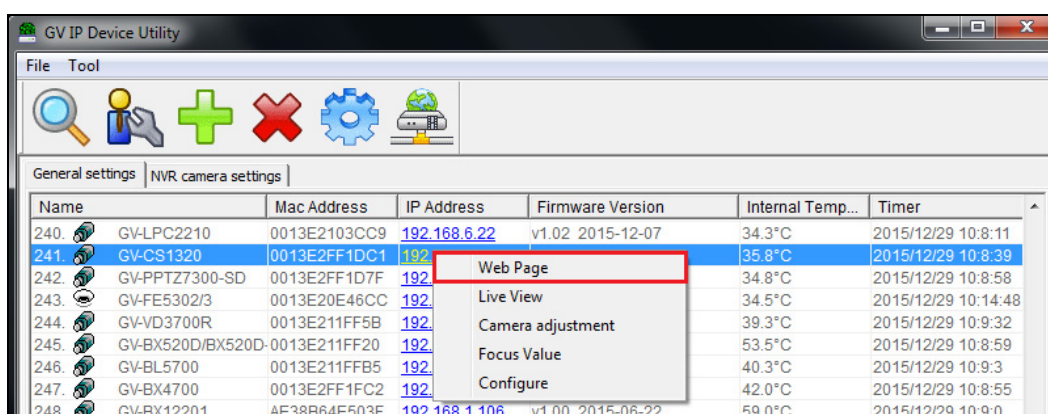

Figure 2-2

4. On the login page, enter your username and password to login. See *2.1 Creating Login Credentials*.

2.3 Assigning an IP Address

Follow the steps below to assign a new IP address.

Note:

1. GV-CS1320 has a default IP address of 192.168.0.10. The computer used to set the IP address must be under the same network assigned to the unit.
 2. If your router supports the DHCP server, GV-CS1320 will obtain a dynamic IP address from the DHCP server each time it connects to the LAN, instead of using 192.168.0.10.
-

1. Open your web browser, and type the default IP address <http://192.168.0.10>
2. In both Login and Password fields, enter your username and password and click **Apply**.
3. In the left menu, select **Network** and then **LAN** to begin the network settings.

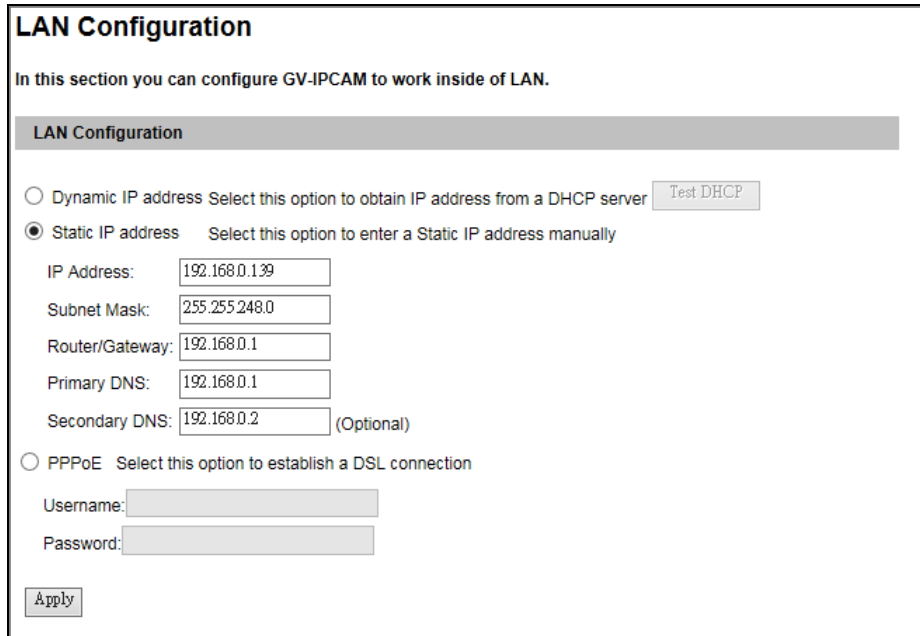

Figure 2-3

4. Select **Static IP address**. Type the IP Address, Subnet Mask, Router/Gateway, Primary DNS and Secondary DNS.
5. Click **Apply**. GV-CS1320 is now accessible by entering the assigned IP address on the web browser.

IMPORTANT:

1. If **Dynamic IP Address** or **PPPoE** is enabled, you need to know which IP address GV-CS1320 will receive from the DHCP server or ISP to log in. If your GV-CS1320 is installed in a LAN, use GV-IP Device Utility to look up its current dynamic address. See [2.2 Checking the Dynamic IP Address](#).
If your GV-CS1320 uses a public dynamic IP address, via **PPPoE**, first use the Dynamic DNS service to obtain a domain name linked to the unit's changing IP address. For details on Dynamic DNS Server settings, see [4.4.3 Advanced TCP/IP](#).
 2. If **Dynamic IP Address** and **PPPoE** is enabled and you cannot access the unit, you may have to reset it to the factory default settings and then perform the network settings again. For details, see [5.3 Restoring to Factory Default Settings](#).
-

Chapter 3 Accessing the Camera Access Controller

Two types of user levels are allowed to log in GV-CS1320: **Administrator** and **Guest**. The Administrator has full access to all system configurations while the Guest can only access the live view and network status.

3.1 Accessing Your Surveillance Images

1. Start the Internet Explorer browser.
2. Type the IP address or domain name of GV-CS1320 in the **Location / Address** field of your browser.

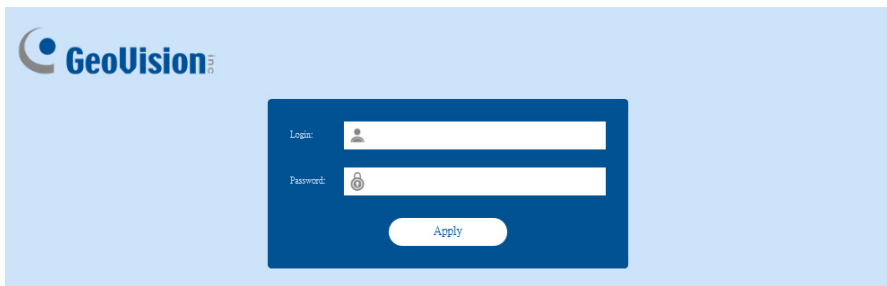

Figure 3-1

3. Enter your username and password.
4. The live web page, similar to the image in *Figure 3-3*, is now displayed on your browser.

For Mozilla Firefox, Google Chrome or Microsoft Edge, click **Run** to execute GV-Web Viewer when prompted by your web browser, type in the IP address of GV-CS1320, and click **Connect** to access the full functioning user interface.

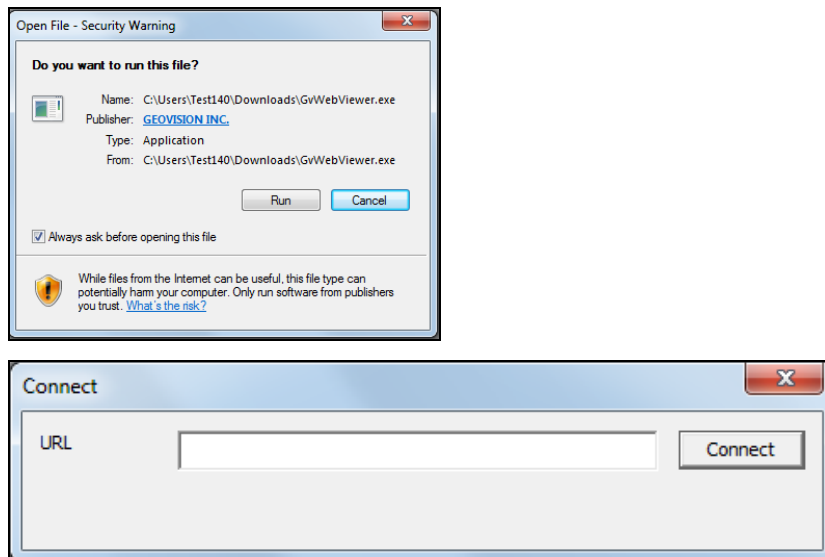

Figure 3-2

Note: To enable the updating of images in Microsoft Internet Explorer, you must set your browser to allow ActiveX Controls and perform a one-time installation of GeoVision's ActiveX component onto your computer.

3.2 Functions Featured on the Main Page

This section introduces the features of the **Live View** window on the main page.

3.2.1 The Live View Window



Figure 3-3

No.	Name	Function
1	Play	Plays live video.
2	Stop	Stops playing video.
3	Microphone	Talks to the surveillance area from the local computer.
4	Speaker	Listens to the audio around GV-CS1320.
5	Snapshot	Takes a snapshot of live video. --- See 3.2.3 <i>Snapshot of a Live Video</i> .
6	File Save	Records live video to the local computer. --- See 3.2.4 <i>Video Recording</i> .

7	Full Screen	<p>Switches to full screen view. Right-click the image to have these options: Snapshot, Digital PTZ, Wide Angle Lens Dewarping, Wide Angle Setting, PIP and PAP.</p> <p>--- See 3.2.5 <i>Digital PTZ</i></p> <p>--- See 3.2.6 <i>Wide Angle Lens Dewarping</i></p> <p>--- See 3.2.7 <i>Picture-in-Picture and Picture-and-Picture View</i></p>
8	Show System Menu	<p>Brings up these functions: Alarm Notify, Video and Audio Configuration, Remote Config, Show Camera Name and Image Enhance.</p> <p>--- See 3.2.8 <i>Alarm Notification</i></p> <p>--- See 3.2.9 <i>Video and Audio Configuration</i></p> <p>--- See 3.2.10 <i>Remote Configuration</i></p> <p>--- See 3.2.11 <i>Camera Name Display</i></p> <p>--- See 3.2.12 <i>Image Enhancement</i> respectively.</p>

3.2.2 The Control Panel of the Live View Window

To open the control panel of the Live View window, click the arrow button on top of the viewer. You can access the following functions by using the left and right arrow buttons on the control panel.

Click the arrow button to display the control panel.

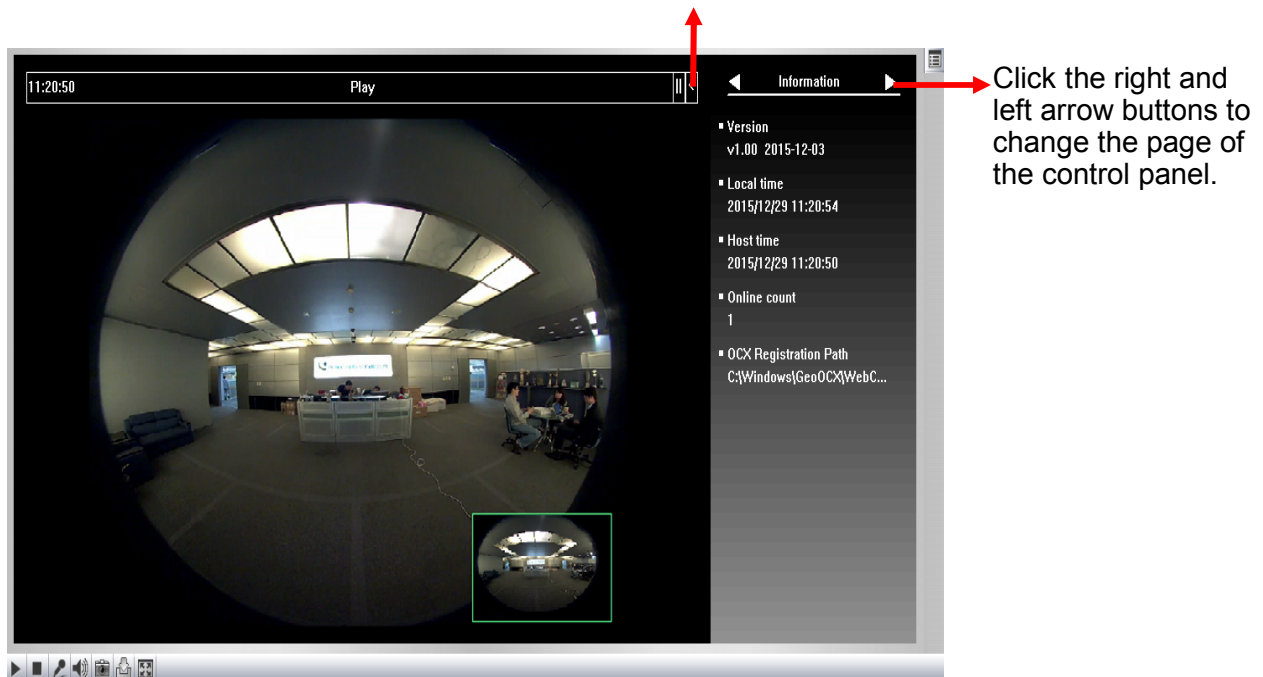

Figure 3-4

[Information] Displays the version of GV-CS1320, local time of the local computer, host time of GV-CS1320, and the number of users logging in to GV-CS1320.

[Video] Displays the current video codec, resolution and data rates.

[Audio] Displays the audio data rates when the microphone and speaker devices are enabled.

[Alarm Notify] Displays the captured images upon sensor triggers. For this function to work, you must configure the Alarm Notify settings first. See *3.2.8 Alarm Notification*.

[Camera Adjustment] Allows you to adjust the image quality.



Figure 3-5

- **Brightness:** Adjusts the brightness of the image.
- **Contrast:** Adjusts the relative differences between one pixel and the next.
- **Saturation:** Adjusts the saturation of the image.
- **Sharpness:** Adjusts the sharpness of the image
- **Gamma:** Adjusts the relative proportions of bright and dark areas
- **White balance:** GV-CS1320 automatically adjusts the color to be closest to the image you are viewing. You can choose one of the four presets: **Auto**, **Outdoor**, **Indoor**, and **Fluorescent**. You can also choose **Manual** to adjust the white balance manually.

- **Flicker less:** GV-CS1320 automatically matches the frequency of your camera access controller's image to the frequency of indoor light sources, e.g. fluorescent lighting. You can also select 50 Hz or 60 Hz manually. If these don't match, faint light and dark bars may appear in your images. Check the power utility to determine which frequency is used.
- **Image Orientation:** Changes the image orientation on the Live View window.
- **Slowest Shutter Speed:** Shutter speed controls the amount of the lights enters the image sensor and directly impacts the quality of image presentation. A slow shutter speed allows higher light exposure that creates a brighter overall image by blurring moving objects and bringing out background details, and a faster shutter speed lowers color and image clarity in order to capture motions.
- **D/N:** Select **Auto** for automatic switch between day mode and night mode depending on the amount of light detected. Select **Black and white** to switch the camera access controller to night mode. Select **Color** to switch the camera access controller to day mode. The value 10 is the most light-sensitive. Select **Trigger by Input** for the externally installed infrared illuminator to turn on under low light and turn off under sufficient light.
- **Denoise:** Reduces image noise especially under low-light conditions. The higher the denoise value, the stronger the effect.
- **Wide Dynamic Range:** adjusts and generates clear live view when the scene contains very bright and very dark areas at the same time. Select **Auto (Strong)** to bring out details in the darks areas of the scene, select **Auto (Weak)** to bring out less detail in the dark area and at the same time keep the bright areas from overexposure, or select **Auto (Normal)** for a balanced effect. Select **Close** to disable the function.
- **Defog:** Select **Auto** to automatically enhance the visibility of images. Select **Close** to disable the function.
- **Super Low Lux:** Select **Auto** for GV-CS1320 to automatically enhance the live view under insufficient light. Select **Close** to disable the function. The default setting is Auto.
- **Metering:** Controls the camera access controller's exposure. Select **Normal** for GV-CS1320 to adjust exposure based on the full live view. Select **Regional Metering** for GV-CS1320 to adjust exposure of specified zones. Draw directly on the live view and a block marked with "AE (automatic exposure)" appears. You can establish up to 4 zones. To remove the block, right-click the block and select **Delete**.
- **Back Light Suppression:** Reduces back light under backlit conditions. Select **Face Enhanced** for FD Scene Mode to access this option (see *4.1.1 Video Settings*). The higher the value, the stronger the effect.

3.2.3 Snapshot of a Live Video

To take a snapshot of live video, follow these steps:

1. Click the **Snapshot** button (No. 5, Figure 3-3). The Save As dialog box appears.
2. Specify **Save in**, type the **File name**, and select **JPEG** or **BMP** as **Save as Type**. You may also choose whether to display the name and date stamps on the image.
3. Click the **Save** button to save the image in the local computer.

3.2.4 Video Recording

You can record live video for a certain period of time to your local computer.

1. Click the **File Save** button (No. 6, Figure 3-3). The Save As dialog box appears.
2. Specify **Save in**, type the **File name**, and move the **Time period** scroll bar to specify the time length of the video clip from 1 to 5 minutes.
3. Click the **Save** button to start recording.
4. To stop recording, click the **Stop** button (No. 2, Figure 3-3).

3.2.5 Digital PTZ

The Digital PTZ (DPTZ) function of GV-CS1320 allows you to simulate the PTZ movement on the screen.

1. Right-click on the live view to display a dropdown list.
2. Select **Digital PTZ**. The PTZ control panel appears.



Figure 3-6

3. To change the direction, click the **Arrow** buttons.
4. To zoom in / out, click the corresponding buttons or use the mouse scroll. To bring the live view back to its default image, click **Home**.

3.2.6 Wide Angle Lens Dewarping

Use the Wide Angle Lens Dewarping function to reduce the warping of live view.

1. Right-click on the live view to display a dropdown list.
2. Select **Wide Angle Setting**. The Wide Angle Dewarping Setting window appears.

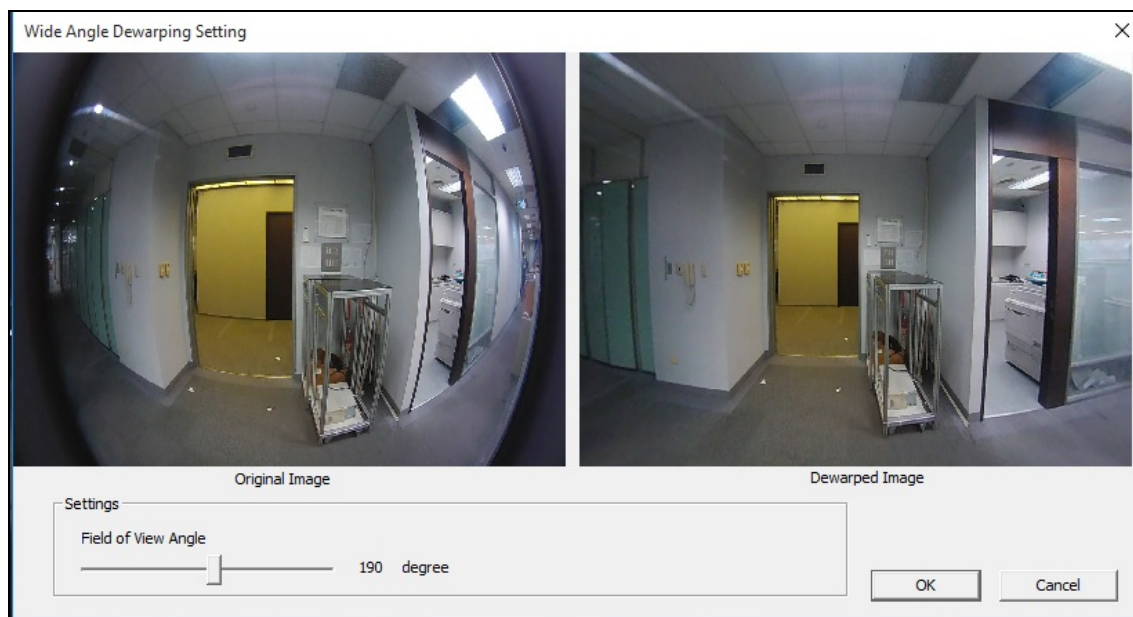

Figure 3-7

3. Slide the slider at the bottom to correct the degree of warping. The adjusted view is shown on the right. Click **OK** to close this window.
4. To enable this configuration, right-click on the live view, select **Wide Angle Lens Dewarping**.

3.2.7 Picture-in-Picture and Picture-and-Picture View

Two types of close-up views are available to provide clear and detailed images of the surveillance area: **Picture-in-Picture (PIP)** and **Picture-and-Picture (PAP)**. After entering the live view window, the image is displayed in PIP mode by default.

Picture-in-Picture View

With the Picture in Picture (PIP) view, you can crop the video to get a close-up view or zoom in on the video.

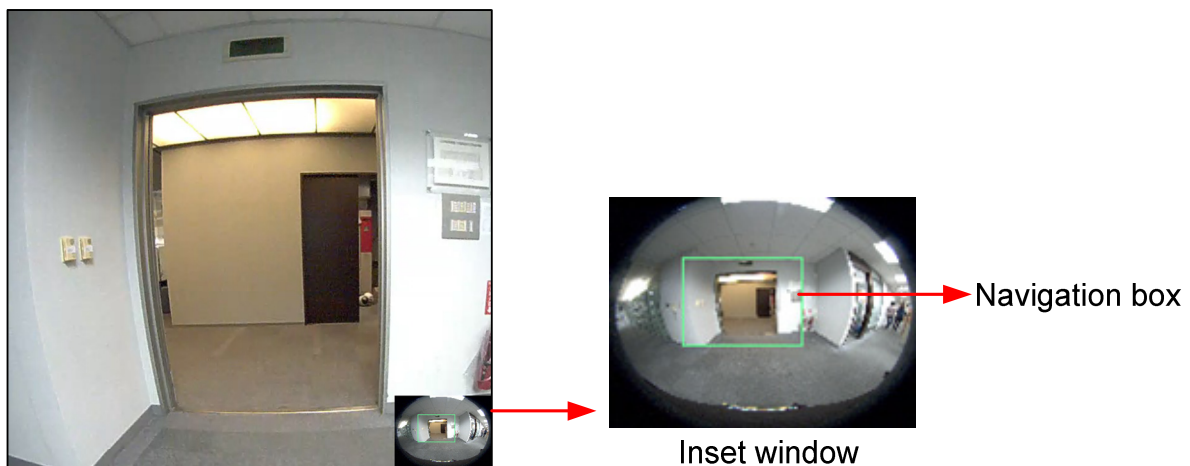

Figure 3-8

1. Right-click the live view and select **PIP**. An inset window appears.
2. Click the inset window. A navigation box appears.
3. Move the navigation box around in the inset window to have a close-up view of the selected area.
4. To adjust the navigation box size, move the cursor to any of the box corners, and enlarge or diminish the box.
5. To exit the PIP view, right-click the image and click **PIP** again.

Picture-and-Picture View

With the Picture and Picture (PAP) view, you can create a split video effect with multiple close-up views on the image. A total of 7 close-up views can be defined.



Figure 3-9

1. Right-click the live view and select **PAP**. Three inset windows appear at the bottom.
2. Draw a navigation box on the image, and this selected area is immediately reflected in one inset window. Up to seven navigation boxes can be drawn on the image.
3. To adjust a navigation box size, move the cursor to any of the box corners, and enlarge or diminish the box.
4. To move a navigation box to another area on the image, drag it to that area.
5. To change the frame color of the navigation box or hide the box, right-click the image, select **Mega Pixel Setting** and click one of these options:
 - **Display Focus Area of PAP Mode:** Displays or hides the navigation boxes on the image.
 - **Set Color of Focus Area:** Changes the color of the box frames.
6. To delete a navigation box, right-click the desired box, select **Focus Area of PAP Mode** and click **Delete**.
7. To exit the PAP view, right-click the image and click **PAP** again.

3.2.8 Alarm Notification

After motion detection, you can view up to four captured images.



Figure 3-10

For this function to work, click the **Show System Menu** button (No. 8, Figure 3-3), and select **Alarm Notify**. In the pop-up dialog box, configure the following settings.

- **Motion Notify:** Enable the option to capture images upon motion detection, and display the captured ones on the control panel of the Live View window.
- **Alert Sound:** Activates the computer alarm upon motion detection.
- **Auto Snapshot:** The snapshot of live view is taken every 5 seconds upon motion detection.
- **File Path:** Assigns a file path to save the snapshots.

3.2.9 Video and Audio Configuration

You can enable the microphone and speaker for two-way audio communication and set the number of frames to keep for live view buffer. Click the **Show System Menu** button (No. 9, Figure 3-3), and select **Video and Audio Configuration**.

- **Camera:** Sets the number of frames to keep in live view buffer. Keeping more frames for live view buffer can ensure a smooth live view, but the live view will be delayed for the number of frames specified.

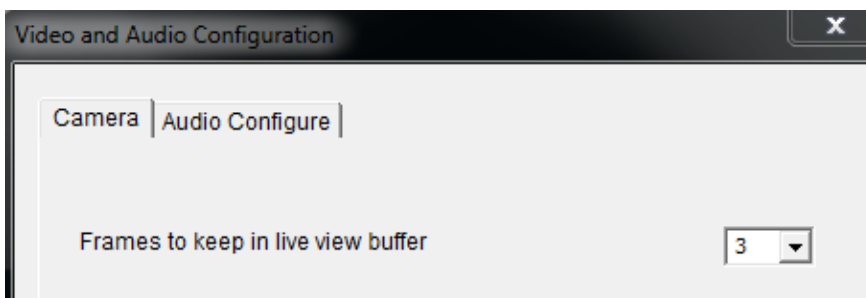

Figure 3-11

- **Audio Configure:** You can enable the microphone and speaker and adjust the audio volume.

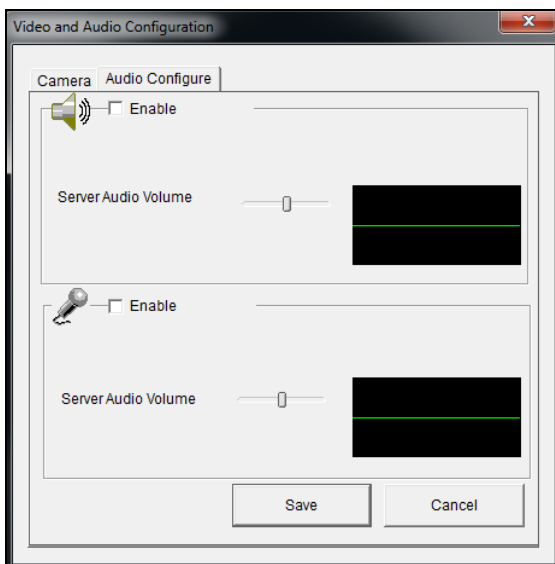

Figure 3-12

3.2.10 Remote Configuration

You can upgrade firmware over the network. Click the **Show System Menu** button (No. 9, Figure 3-3), and select **Remote Config**. For details, see *5.1.1 Using the Web Interface*.

3.2.11 Camera Name Display

To display the camera access controller's name on the image, click the **Show System Menu** button (No. 9, Figure 3-3), and select **Show Camera Name**.

3.2.12 Image Enhancement

To enhance the image quality of live video, click the **Show System Menu** button (No. 9, Figure 3-3), and select **Image Enhance**. This dialog box appears.

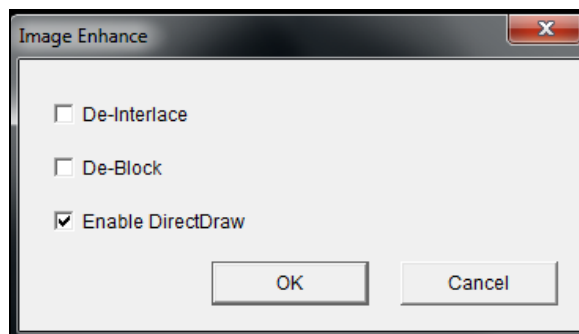

Figure 3-13

- **De-Interlace:** Converts the interlaced video into non-interlaced video.
- **De-Block:** Removes the block-like artifacts from low-quality and highly compressed video.
- **Enable DirectDraw:** Activates the DirectDraw function.

Chapter 4 Administrator Mode

The Administrator can access system configuration of GV-CS1320 through the network. The following configuration categories are available: **Video, Access Control, Events and Alerts, Network, Management and SIP.**

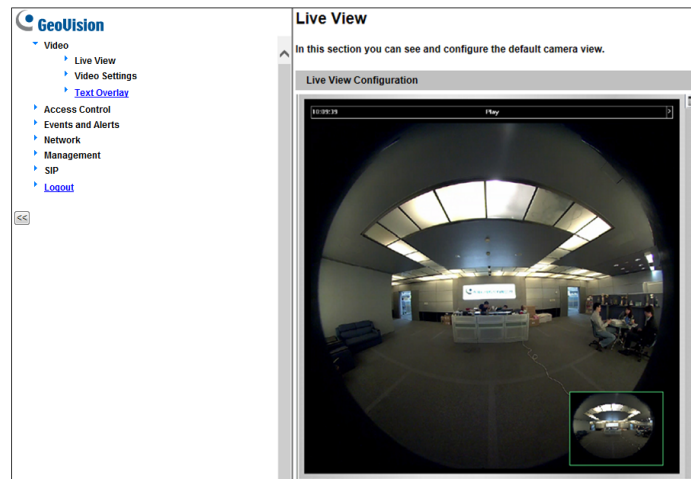

Figure 4-1

List of Menu Options

Find the topic of interest by referring to the section number prefixed to each option.

4.1 Video & Motion	4.1.1 Video Settings 4.1.2 Text Overlay
4.2 Access Control	4.2.1 Basic Setting 4.2.2 Extended Device
4.3 Events and Alerts	4.3.1 RTSP/ONVIF
4.4 Network	4.4.1 Status 4.4.2 LAN 4.4.3 Advanced TCP/IP 4.4.4 IP Filtering 4.4.5 SNMP Setting
4.5 Management	4.5.1 Date and Time 4.5.2 Storage Settings 4.5.3 User Account 4.5.4 Log Information 4.5.5 Tools 4.5.6 Language
4.6 SIP	4.6.1 SIP Setting
Note: Motion Detection, found under Video and Motion setting, is nonfunctional.	

4.1 Video and Motion

GV-CS1320 supports dual streams, Streaming 1 and Streaming 2, which allow separate codec and resolutions settings for a single video transmission. In a bandwidth-limited network, such as mobile phone surveillance, this dual-stream feature allows you to view live video in lower resolution (Streaming 2), and record in highest resolution (Streaming 1) at the same time.

Comparison between Stream 1 and Stream 2:

Video Setting Options	Stream 1	Stream 2
Video Signal Type	Different codec, resolutions and frame rates can be applied to Stream 1 and 2.	
Watermark Setting	Yes	Not configurable. Settings in Stream 1 will be automatically applied to Stream 2.
Special View Setting		

4.1.1 Video Settings

Video Settings

In this section you can define compression art, broadcasting method and privacy mask.

Video Signal Type

In this section you can configure camera's video signal, also the resolution and frame per second to be transmitted through the network

Video Format

Resolution	Frame per second
<input type="text" value="1920*1080 (16:9)"/>	<input type="text" value="15"/>

Bandwidth Management

In this section you can configure the bit rate used by video stream. When VBR (Variable Bit Rate) is selected, consistent image quality is achieved at the cost of varying bit rate. To set a consistent bit rate at the cost of varying image quality, select CBR (Constant Bit Rate).

<input checked="" type="radio"/> VBR	Quality <input type="text" value="Good"/>	Maximal Bit Rate <input type="text" value="8"/>	Mbit
<input type="radio"/> CBR	Maximal Bit Rate <input type="text" value="2048"/>	Kbps	<input type="text" value="Quick List"/>

Region Of Interest (ROI)

In this section you can configure ROI of H.264.

Enable [ROI Setting](#)

GOP Structure and Length

In this section you can configure the composition of the video stream (GOP structure). Using I-Frame only will significantly increase the video quality as well as the bandwidth.

Group of Picture(GOP) Size (seconds)

H264 Video Entropy Coding Setting

In this section you can decide Video entropy coding for H.264 codec

H.264 Entropy Encoding

Text Overlay Settings

In this section you can set up texts to be overlaid on live view when viewing via GeoVision software.

Camera Name

Overlay with:

Camera Name

Date

System Time

Figure 4-2a

Text Overlay Settings (OSD)

In this section you can set up texts to be overlaid on live view.

Camera Name

Font Size

Overlay with:

Camera Name

Date

System Time

Watermark Setting

In this section you can set Watermark function.

Enable

LED Control

Ready LED Enable Disable

Enable SDK

Enable

Special View Setting

Additional functions for Live View

D/N

<input checked="" type="radio"/>	Auto	Sensitivity <input type="text" value="3"/>
<input type="radio"/>	Black and White	
<input type="radio"/>	Color	

BLC Off On

IR Light Auto Off

FD Scene Mode

Mode

Figure 4-2b

[Connection Template] Select the type of your network connection. Unless you select **Customized**, this option will automatically bring up the recommended frame rate.

[Video Signal Type] Configure the codec type, signal format, resolution and frame rate. Select between **H.264** and **MJPEG** as the codec type.

The codec options, resolutions and maximum frame rates are listed as below:

Streams	Codec Options	Image Resolution	Max Frame Rate
Stream 1	H.264, MJPEG	1920 x 1080	15 fps
Stream 2	H.264, MJPEG	640 x 360	15 fps

[Bandwidth Management] When using the H.264 code, you can select constant bitrate or variable bitrate to control the bandwidth usage.

- **VBR (Variable Bitrate):** The quality of the video stream is kept as constant as possible at the cost of a varying bitrate. The bandwidth is used much more efficiently than a comparable CBR. You can set a limit to the bit rate by specifying a **Maximal Bit Rate**. Set the image quality to one of the 5 standards: **Standard, Fair, Good, Great, and Excellent**.
- **CBR (Constant Bitrate):** CBR is used to achieve a specific bitrate by varying the quality of the stream. Select a bitrate from the **Maximal Bit Rate** dropdown list.

[GOP Structure and Length] Set the maximum number of seconds between every key frame. This option is only available when H.264 is selected for codec.

[H.264 Video Entropy Coding Setting] By default, the entropy coding is set to CAVLC. To change it to **CABAC**, click and select from the dropdown list.

[Text Overlay Settings] Displays camera name, date, and/or time on the live view and recorded videos when viewing through GeoVision software.

- **Camera:** Type the camera name.
- **Overlay with:** Select one or more of the options to be overlaid on the live view and recorded videos: Camera Name, Date and System Time.

[Text Overlay Settings (OSD)] Displays camera name, date, and/or time on the live view and recorded videos when viewing through GeoVision software and third-party software through ONVIF and RTSP.

- **Camera Name:** Type the camera name.
- **Font Size:** Select the font size from 1x to 5x.
- **Overlay with:** Select one or more of the options to be overlaid on the live view and recorded videos: Camera Name, Date and System Time, and select the display position

[Watermark] Enable this option to watermark all recordings. The watermark allows you to verify whether the recorded video has been tampered with. See *5.4 Verifying Watermark*.

[Special View Setting]

- **D/N:** Sets the Day/Night mode of GV-CS1320.
 - ⊙ **Auto:** Select **Auto** for GV-CS1320 to detect the amount of light present and automatically switch to monochrome in a poorly-lit scene. Use the dropdown list to adjust the sensitivity level of light sensor from 1 to 5. The higher the value, the more sensitive GV-CS1320 is to light.
 - ⊙ **Black and White:** Select this option for the live view to be in monochrome.
 - ⊙ **Color:** Select this option for the live view to be in color.

[BLC] Enable the backlight compensation to adjust the exposure when the subject is positioned in front of a bright light source.

[IR Light] Enable or disable the IR LEDs (No. 4, Figure 1-5).

[FD Scene Mode]: When connected to GV-AI FR Server, face detection accuracy may be reduced under backlit conditions. To improve accuracy, select **Face Enhanced** to enable **Back Light Suppression** in the control panel of the Live View window (see Figure 3-5).

Note:

1. The functions **Region of Interest (ROI)**, **LED Control** (Ready LED), **Enable SKD** in the Video Setting page don't work with GV-CS1320.
 2. Selecting "Face Enhanced" for FD Scene Mode will reset all settings under Camera adjustment.
-

4.1.2 Text Overlay

The Text Overlay allows you to overlay any text in any place on the camera view. Up to 16 text messages can be created on one camera view. The overlaid text will be saved in the recordings.

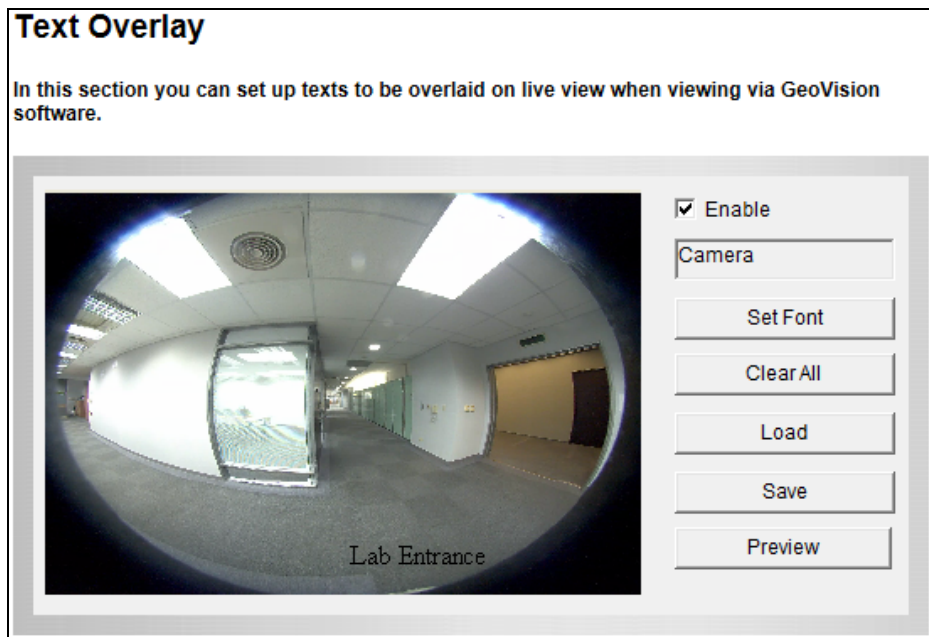

Figure 4-3

1. Select the **Enable** option.
2. Click **Set Font** to set up the font, font style and font size in a pop-up window.
3. Click any place on the image. This dialog box appears.

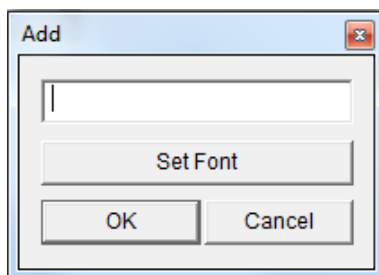

Figure 4-4

4. Type the desired text, and click **OK**. The text is overlaid on the image.
5. Drag the overlaid text to a desired place on the image.
6. Click **Set Font** to modify the font settings.
7. Click **Save** to apply the settings, or click **Load** (Undo) to revert to the last saved setting.
8. Click **Preview** to see how the text will appear on the image. Click **Close** to end the preview.

4.2 Access Control

Under Access Control, there are two sections, **Basic Setting** and **Extended Device**, you can choose from to configure the controller settings on the left menu of the Web interface.

4.2.1 Basic Setting

The Basic Setting section covers function setting, door parameter configuration, card setting, input and other settings.

Changes in some of the Basic Setting page will affect the options available on other pages. The diagram below shows the relationships between each Basic Setting page.

The Relationship Diagram between each Basic Setting Page

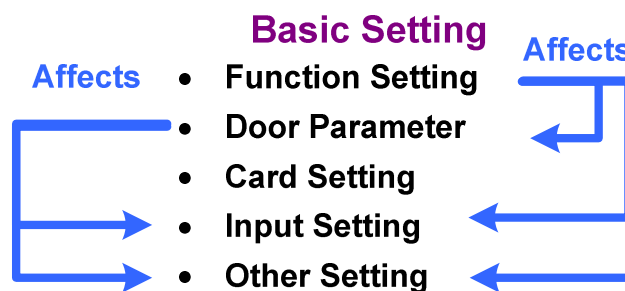

Figure 4-5

4.2.1.1 Function Setting

With the function setting, you can assign certain authentication methods for controlling a door/gate or an elevator.

Function Configuration	
ID	
ID	<input type="text" value="1"/>
Door/Gate A	
Function	<input type="text" value="Door Entry Control"/>
Authentication Mode	<input type="text" value="Authentication Schedule Mode"/>
Series Function(APB & Fire)	
Enable/Disable	<input type="text" value="Disable"/>
Info IP	<input type="text" value="00.00"/>
<input type="button" value="Apply"/>	

Figure 4-6

[ID] Enter the ID number for the controller. This ID is used by GV-ASManager to differentiate among multiple units of controllers. The ID number can only be between 1 and 1000.

[Door/Gate #] [Elevator] Select the function type and the authentication mode for the use of the Doors / Gates / Elevators.

- **Function:** Select the function for GV-CS1320 to be installed in a general door / parking place and an elevator for entry or exit access control.
 - ⊙ **Door Entry Control**
 - ⊙ **Parking Entry Control**
 - ⊙ **Door Exit Control:**
 - ⊙ **Parking Exit Control**
 - ⊙ **Elevator Control**

- **Authentication Mode:** Select the authentication mode for the Doors/Gates or Elevator.
 - ⊙ **Local Unlock Mode:** Remains open. The held-open state cannot be cleared through GV-ASManager.
 - ⊙ **Local Lock Mode:** Remains locked. The locked state cannot be cleared through GV-ASManager.
 - ⊙ **Fixed Card Mode:** Grants access after the card is presented or the passcode is entered, and ignores the authentication schedule of GV-ASManager.
 - ⊙ **Fixed Card + PIN Mode:** Grants access after the user presents the card and enters the card's PIN code, and ignores the authentication schedule of GV-ASManager.
 - ⊙ **Fixed Card/Common mode:** Grants access after the user presents the card or enters the door's password, and ignores the authentication schedule of GV-ASManager.
 - ⊙ **Authentication Schedule Mode:** Follows the authentication schedule set on GV-ASManager.
 - ⊙ **Local Lock Down:** Locks down the door. This mode overrides the Authentication Schedule and the door can only be opened by presenting the assigned access card.

[Series Function (APB & Fire)] This option lets you set the Anti-Passback function and fire sensor function across multiple door controllers. The Anti-Passback means that a card used on an entry door cannot access the same entry door again unless it has been used on a corresponding exit door.

- **Enable/Disable:** Enables or disables the Anti-Passback function and fire sensor function.
- **Info IP:** Enter the IP address of the next corresponding controller.

Note: GV-CS1320 does not support fire sensor inputs. However, the output of GV-CS1320 will be triggered when the fire sensors on one door of its associated controller is triggered.

4.2.1.2 Door Parameter

The content of the Parameter Configuration page change is based on your settings for **Door/Gate #** in the **Function Configuration** page (Figure 4-6).

Parameter Configuration

Events

Anti-passback

Lock Reset Time (1~255);

Held Open Time (5~9999);

Fire Action

Alarm Continuous Time (1~10)

Alarm

Door Held Open Alarm

Door Forced Open Alarm

Door Access Denied Alarm

Global Fire Alarm

UrgentCode Alarm

Common Password

Common Password

Password Confirm

Figure 4-7

[Events]

Set the parameters for the events.

- When **Door Control** is selected in the **Function Configuration** page (Figure 4-6), these options become available:

Option	Description
Anti-Passback	Enables or disables the Anti-Passback function.
Lock Reset Time	Sets the time (1 to 255 sec.) that a door remains open after which the door will automatically be locked.
Held Open Time	Sets the time (5 to 9999 sec.) that a door can be held open before an alarm is generated.
Fire Action	Locks or unlocks the door when a fire condition occurs. Otherwise, remains the door's current state by selecting <i>Unchanged</i> .
Alarm Continuous Time	Sets the time (1 to 10 sec.) that the alarm will continuously go off before it ends.

- When **Parking Control** is selected in the **Function Configuration** page (Figure 4-6), these options become available:

Option	Description
Anti-Passback	See the same option above.
Relay On Time	Sets the time (1 to 255 sec.) that a gate remains open after which the gate will automatically be closed.
Held Open Time	See the same option above.
Fire Action	
Alarm Continuous Time	

- When **Elevator Control** is selected in the **Function Configuration** page (Figure 4-6), these options become available:

Option	Description
Relay on Time	See the same option above.
Fire Action	
Alarm Continuous Time	See the same option above.

Note: GV-CS1320 does not support fire sensor inputs. The **Fire Action** and **Global Fire Alarm** options must work with the Anti-Pass Back (APB).

[Alarm] Select **Yes** or **No** to enable or disable the alarm function. The default settings for all the alarms are set to **NO**.

- When **Door Control** is selected in the **Function Configuration** page (Figure 4-6), these options become available:

Option	Description
Door Held Open	This alarm activates whenever the door is held open over the set period of time.
Door Forced Open	This alarm activates whenever the door is opened by force.
Door Access Denied	This alarm activates whenever entry is denied due to using the wrong card or entering the wrong password.
Global Fire	This alarm activates whenever fire is detected.
Urgent Code	This alarm activates whenever an emergency arises at the door.

[Common Password] When **Fixed Card/Common Mode** is selected as **Authentication Mode** in the **Function Configuration** page (Figure 4-6), you can gain access by using the card or entering this Common Password (door’s password).

4.2.1.3 Card Setting

In the Card Setting page, you can set up face detection and select an identification type for your reader.

Card Configuration

Face Detection Setting

Show a box around each detected face

Show face detection area

Sensitivity

Enable card and face mode

Card Identify

Identification type

Figure 4-8

[Face Detection Setting]

- **Show a box around each detected face:** Select this option to draw a box around each detected face on the camera view.
- **Show face detection area:** Show the face detection area on the camera view to indicate the area where face detection is supported.
- **Sensitivity:** Select a sensitivity level for face detection.
- **Enable card and face mode:** Select this option to require a card to be presented and a face to be detected before access is granted. The LED Indicator will flash red if the camera reader controller fails to detect the face.

[Card Identify]

- **Identification type:** Set the built-in card reader of GV-CS1320 to read UID (unique identification) or GID (GeoVision identification) on GV-AS ID F Card / Key Fob.

To use **GeoVision Identification (GID)**, make sure there are two numbers on your GV-AS ID Cards / Key Fobs as shown below. If there is only one number on your GV-AS ID Cards / Key Fobs, GID is not supported and you must select **Unique Identification (UID)**.

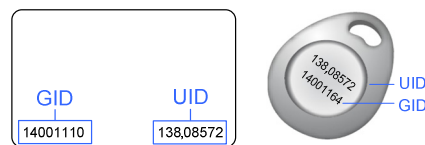

Figure 4-9

Note:

1. If face detection fails, the card will not be recognized by GV-CS1320.
 2. When **Card and Face** mode is enabled, the cardholder should stand in front of GV-CS1320 for at least 5 seconds to allow face detection before presenting the card.
 3. When **Night** mode is enabled, the built-in IR LEDs may be automatically switched off at the time of face detection for approximately 2 seconds whenever a card is swiped through GV-CS1320.
-

4.2.1.4 Input Setting

The Input Setting is used to define the input devices connected to GV-CS1320.

CS1320 Input Configuration	
Input Function	
01 Door/Car Sensor	NO ▼
02 Door/Gate Button	NO ▼
<input type="button" value="Apply"/>	

Figure 4-10

[Input Function] Set the input contact types to be normally open or normally closed. The default settings for all the inputs are set to **NO**.

4.2.1.5 Other Setting

Here you can specify the encryption code and device port of GV-CS1320 which are used when connecting to GV-ASManager.

Other Configuration	
3DES Code	
3DES Code1 (8 ~ 24 characters long)
3DES Code2	(optional)
3DES Code3	(optional)
GV-ASManager Configuration	
Device Port	4000 (from 1025 to 65535)
GV-ASManager Connection Status	OK
<input type="button" value="Submit"/>	

Figure 4-11

- **3DES Code 1-3:** Stands for Triple DES (Data Encryption Standard). Type up to three different keys for data encryption. The default 3DES Code1 is **12345678**.
- **Device Port:** Keep the default value **4000** or modify it to match that of GV-ASManager's.

4.2.2 Extended Device

You can define GeoVision readers and GV-I/O Box 4 ports connected to GV-CS1320.

4.2.2.1 Extended Reader

Define the readers connected to the controller, and then use the Function dropdown list to select the door option associated with the reader.

CS1320 Extended Reader Configuration

GV-Reader/CR420/GF1921/GF1922/OSDP Function

RS485 Protocol GV OSDP Two-Factor-Authentication

RS485	ID	Serial Number	Functions	Connection Status
<input type="checkbox"/>	0	<input type="text"/>	No Function ▼	
<input type="checkbox"/>	1	<input type="text"/>	Door/Gate A Exit ▼	

OSDP Speed/Baudrate ▼

GeoFinger Server IP Address (from 1025 to 65535)

Figure 4-12

[Protocol]

- **GV:** For the following GeoVision readers, select this protocol.
 - ⊙ **GV-RK1352 / R1352 / DFR1352:** Select the **RS-485** checkbox and type the **Serial Number** of the reader. The ID number located next to the serial number field will be assigned to the reader.
 - ⊙ **Reader 1352 V2:** Select the **RS-485** checkbox and leave the serial number field blank. Note that the ID number located next to the serial number field need to match the reader's ID number defined by the dip switches on the reader.
 - ⊙ **GV-GF1921 / GF1922:** Type the **MAC address** of the fingerprint reader and *do not* select the RS-485 checkbox.
 - ⊙ **GV-CR420:** Select the **RS-485** checkbox only if GV-CR420 is connected to the controller through RS-485 connection. If the reader is connected via network, do not check the RS-485 checkbox. Type the **MAC address** of GV-CR420 if using the latest GV-CR420 firmware.
 - ⊙ **GV-FR2020:** Type the **MAC address** of the face recognition reader and *do not* select the RS-485 checkbox.

- **OSDP:** For OSDP compliant readers, e.g. GV-RKD1352, select this protocol and select the paired ID No. of the reader (ID #1 ~#2).
- **Two-Factor Authentication:** Only for *networked* readers supporting face / finger recognition, the access is granted only when registered faces / fingers are detected and corresponding cards are presented too. Once registered faces / fingers are detected, GV-CS1320 will beep once and flash green lights for 10 seconds, during which users must present corresponding cards for access granted.

[GeoFinger Server IP Address]

To allow GV-ASManager to receive data from GV-GF1921 / 1922 defined on this page during remote fingerprint enrollment, type the IP address and port of GV-ASManager server. By default the port number is 2167.

Click **Apply**. The green Connection Status indicates the successful connection between GV-CS1320 and the reader whereas a red status indicates otherwise.

Note:

1. To allow network connection, you must also enable network connection to the controller on the Web interface of GV-CR420 or GV-GF1921 / 1922.
 2. The extended reader connected is limited to use UID (unique identification) card type. For details on card authentication, see [Card Identify] in 4.2.1.3 *Card Setting*.
-

4.2.2.2 Extended IOBOX 4 Ports

For **Extended IOBOX Configuration**, see *Chapter 8 Connecting to GV-I/O Box 4 Ports*.

4.3 Events and Alerts

4.3.1 RTSP/ONVIF

The RTSP enables video and audio streaming to your mobile phone. And, you can configure the ONVIF settings for a third-party DVR and access controllers to connect to GV-CS1320.

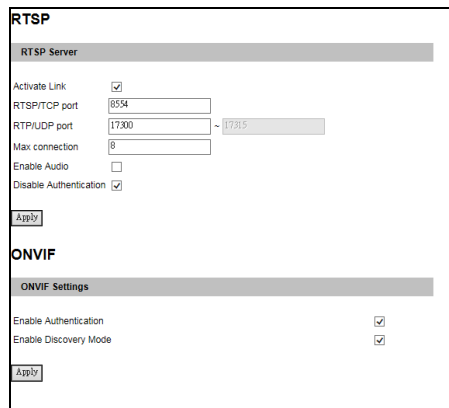

Figure 4-13

[RTSP]

- **Activate Link:** Enable the RTSP protocol.
- **RTSP/TCP Port:** Keep the default value 8554, or modify it if necessary.
- **RTP/UDP Port:** Keep the default range from 17300 to 17315, or modify it if necessary. The number of ports for use is limited to 20.
- **Max Connection:** Set the maximum number of connections to GV-CS1320. The maximum value is 8.
- **Enable Audio:** Turns the audio streaming on or off.
- **Disable Authentication:** By default, when accessing live view through the RTSP command, the ID and password of GV-CS1320 are required. Select this option to disable the authentication prompt.

[ONVIF]

- **Enable Authentication:** The ID and password of GV-CS1320 are required to access GV-CS1320 by a third-party DVR through ONVIF. This function is enabled by default.
- **Enable Discovery Mode:** Allows the third-party DVR to browse GV-CS1320. This function is enabled by default.

For details on the RTSP command, see *RTSP Protocol Support* in *Appendix B*.

4.4 Network

The Network section includes some basic but important network configurations that enable GV-CS1320 to be connected to a network.

4.4.1 Status

You can access an overview of GV-CS1320's network status.

Network Status Information

In this section you can see an overview of GV-IPCAM status.

Current Status Information	
interface:	Wired
IP Acquirement:	Fixed
MAC Address:	0013E2FF1DC1
IP Address:	192.168.6.4
Subnet Mask:	255.255.248.0
Gateway:	192.168.0.1

Figure 4-14

4.4.2 LAN

According to your network environment, select among DHCP, static IP and PPPoE.

LAN Configuration

In this section you can configure GV-IPCAM to work inside of LAN.

LAN Configuration	
<input checked="" type="radio"/> Dynamic IP address	Select this option to obtain IP address from a DHCP server <input type="button" value="Test DHCP"/>
<input type="radio"/> Static IP address	Select this option to enter a Static IP address manually
IP Address:	<input type="text" value="192.168.3.13"/>
Subnet Mask:	<input type="text" value="255.255.248.0"/>
Router/Gateway:	<input type="text" value="192.168.0.1"/>
Primary DNS:	<input type="text" value="192.168.0.1"/>
Secondary DNS:	<input type="text" value="0.0.0.0"/> (Optional)
<input type="radio"/> PPPoE	Select this option to establish a DSL connection
Username:	<input type="text"/>
Password:	<input type="text"/>
<input type="button" value="Apply"/>	

Figure 4-15

[LAN Configuration]

- **Dynamic IP address:** The network environment has a DHCP server which will automatically assign a dynamic IP address to GV-CS1320. Click the **Test DHCP** to see the currently assigned IP address or look up the address using GV-IP Device Utility.
- **Static IP address:** Assign a static IP or fixed IP to GV-CS1320. Type GV-CS1320's IP address, Subnet Mask, Router/Gateway, Primary DNS server and Secondary DNS server.

Parameters	Default
IP address	192.168.0.10
Subnet Mask	255.255.255.0
Router/Gateway	192.168.0.1
Primary DNS server	192.168.0.1
Secondary DNS server	192.168.0.2

- **PPPoE:** The network environment is xDSL connection. Type the Username and Password provided by ISP to establish the connection. If you use the xDSL connection with dynamic IP addresses, first use the DDNS function to obtain a domain name linking to GV-CS1320's changing IP address.

4.4.3 Advanced TCP/IP

This section introduces the advanced TCP/IP settings, including the DDNS Server, HTTPS port, streaming port, UPnP and QoS.

Advanced TCP/IP

In this section you can set the advanced TCP/IP configuration

Dynamic DNS Server Settings

In this section you can configure your GV-IPCAM to obtain a domain name by using a dynamic IP.

Enable

Service Provider: Geovision GVDIP ex: [Register Geovision DDNS Server](#)

Host Name:

User Name:

Password:

Update Time : [Refresh](#)

HTTPS Settings

Use customized certification and private key. External storage is necessary.

Certificate File:

Certificate Key File:

Password:

GV-IPCAM Streaming Port Settings

In this section you can configure Streaming connection from a determine port. The default setting is 10000.

VSS Port:

UPnP Settings

In this section you can enable or disable UPnP function.

UPnP: Enable Disable

QoS Settings

QoS DSCP Settings. The DSCP value can be in decimal or hexadecimal format between 0~63

DSCP Value:

Figure 4-16

[Dynamic DNS Server Settings]

DDNS (Dynamic Domain Name System) provides a convenient way of accessing GV-CS1320 when using a dynamic IP. DDNS assigns a domain name to GV-CS1320, so that the Administrator does not need to go through the trouble of checking if the IP address assigned by DHCP Server or ISP (in xDSL connection) has changed.

Before enabling the following DDNS function, the Administrator should have applied for a Host Name from the DDNS service provider's website. There are 3 providers listed in GV-CS1320: GeoVision GVDIP, GeoVision DDNS Server and DynDNS.org.

To enable the DDNS function:

1. **Enable:** Enable the DDNS function.
2. **Service Provider:** Select the DDNS service provider you have registered with.
3. **Host Name:** Type the host name used to link to GV-CS1320. For users of GeoVision DDNS Server, it is unnecessary to fill the field because the system will detect the host name automatically.
4. **User Name:** Type the user name used to enable the service from the DDNS.
5. **Password:** Type the password used to enable the service from the DDNS.
6. Click **Apply**.

[HTTPS Settings]

By enabling the Hypertext Transfer Protocol Secure (HTTPS) settings, you can access GV-CS1320 through a secure protocol. You can use self-generated Certificate File and Certificate Key File or the ones verified by the SSL authority. Click **Browse** to locate the Certificate File and Certificate Key File and type the password if the .pem files are protected by password. Click **Apply**. The Web interface will be restarted and you will need to log in again.

Note: The .pem file format is supported by the Certificate File and Certificate Key File.

[GV-IPCAM Streaming Port Settings]

The VSS port enables your GV-CS1320 to be connected to GV-DVR / NVR / GV-VMS and to send images to GV-ASManager. The default setting is **10000**.

[UPnP Settings]

UPnP (Universal Plug & Play) is a networking architecture that provides compatibility among networking equipment, software and peripherals of the 400+ vendors that are part of the Universal Plug and Play Forum. It means that they are listed in the network devices table for the operating system (such as Windows XP) supported by this function. Enabling this function, you can connect to GV-CS1320 directly by clicking on the camera listed in the network devices table.

[QoS Settings]

The Quality of Service (QoS) is a bandwidth control mechanism that guarantees delay-sensitive data flows such as voice and video streams and obtains a certain amount of bandwidth to keep the streaming smooth.

To apply QoS to the camera reader, all network routers must support QoS and QoS must be enabled on these devices. To enable the QoS on the camera, enter a Differentiated Services Code Point (DSCP) value. This value is a field in an IP packet that enables different levels of services for the network traffic. When the video stream from the camera reaches a router, the DSCP value will tell the router what service level to be applied, e.g. the bandwidth amount. This value ranges from 0 to 63 in decimal format. The default value is 0, meaning QoS is disabled.

Note: If you do not intend to connect GV-CS1320 to the network, disable this function to prevent automatic reboot.

4.4.4 IP Filtering

The Administrator can set IP filtering to restrict access to GV-CS1320.

IP Filter Setting

In this section you can allow or deny network connection listed in the table. (Only 4 filter entries are supported.)

IP Filtering

Enable IP Filtering

No.	IP Address Range in CIDR format	Action	Customize
The IP Filter has not been configured yet			

Filtered IP: ex: 192.168.1.2 or 192.168.1.0/24

Action to take: Allow ▼

Figure 4-17

To enable the IP Filter function:

1. **Enable IP Filtering:** Enable the IP Filtering function.
2. **Filtered IP:** Type the IP address from which you want to restrict the access.
3. **Action to take:** Select the action of **Allow** or **Deny** to be taken by the IP address(es) you have specified.
4. Click **Apply**.

4.4.5 SNMP Setting

The Simple Network Management Protocol (SNMP) allows you to monitor the status of GV-CS1320 through SNMP network management software.

SNMP Settings

In this section you can configure the SNMP settings.

SNMP Configuration

Enable SNMPv1, SNMPv2

Read/Write Name: public

Read Only Name: public

Enable SNMPv3

Read/Write Name: public

Authentication Type: MD5

Authentication Password: [text input]

Current password (Encrypted): [text input]

Read Only Name: public

Authentication Type: MD5

Authentication Password: [text input]

Current password (Encrypted): [text input]

Apply

Figure 4-18

To set up the SNMP settings:

1. Select **Enable SNMPv1 SNMPv2c** to enable the function.
2. To enable access to **Read/Write Name**, type a community string. This will serve as a password to allow read and write access to GV-CS1320 from the SNMP software.
3. To enable **Read Only Name**, type a community string to allow read-only access to the camera from the SNMP software.
4. For a more secured connection, select **Enable SNMPv3** to enable SNMP version 3.
5. To enable access to **Read/Write Name**, type a community string.
6. Select an **Authentication Type** to be used for SNMP requests.
7. Type the **Authentication Password** and **Current Password (Encrypted)**. You will need to type these passwords in the SNMP software to be able to access GV-CS1320.
8. To enable access to **Read Only Name**, type a community string to allows read-only access to GV-CS1320, and set up the **Authentication Type**, **Authentication Password** and the **Current Password (Encrypted)**.
9. Click **Apply** to save the settings.

4.5 Management

The Management section includes the settings of data and time and user account. You can also view the firmware version and execute certain system operations.

4.5.1 Date and Time

The date and time settings are used for date and time stamps on the image.

Date and Time Settings

In this section you can configure time and date or just synchronize with a NTP server.

Date and Time on GV-IPCAM

Mon Dec 28 10:00:27 GMT8:00 2015

Time Zone

(GMT+08:00) China,Hong Kong,Australia Western,Singapore,Taiwan,Russia ▼

Enable Daylight Saving Time

Start (MM/dd/hh/mm)

End (MM/dd/hh/mm)

	Month	The day of the week	Hour
Start Time	<input type="text" value=""/>	<input type="text" value=""/>	<input type="text" value="0"/>
Stop Time	<input type="text" value=""/>	<input type="text" value=""/>	<input type="text" value="0"/>

Synchronized with a Network Time Server

Synchronized with Network Time Server (NTP)

Host name or IP Address:

Update period: 24 hours; Update Time: :

Synchronized with your computer or modify manually

Modify manually

Date (yyyy/mm/dd)

Time (hh:mm:ss)

Synchronized with your computer

Date and time overlay setting

Show date as ▼

(This is a format of date where yyyy stands for year in 4 digits or yy in 2 digits, mm stands for month, and dd stands for day)

Display order

Date prior to time (Ex.2007/05/21 17:00:00)

Time prior to date(Ex.17:00:00 2007/05/21)

Figure 4-19

[Date & Time on GV-IPCAM] Displays the current date and time on GV-CS1320

[Time Zone] Sets the time zone for local settings. Select Enable Daylight Saving Tim to automatically adjust GV-CS1320 for daylight saving time. Select the Start and Stop time to enable the daylight saving function.

[Synchronized with a Network Time Server] By default, GV-CS1320 uses the timeserver to automatically update its internal clock every 24 hours at the Update Time you specified. You can also change the host name or IP setting to the timeserver of interest.

[Synchronized with your computer or modify manually] Manually changes GV-CS1320's date and time or synchronize the camera access controller's date and time with those of the local computer.

[Date and time overlay setting] Select the display format of date and time stamps on the image. For this function to work, you must also enable the **Overlaid with date stamps** and **Overlaid with time stamps** options in Figure 4-2b.

4.5.2 Storage Setting

Note that only the formatting function is available in the setting page. Other settings are nonfunctional. The SD card is used for storing log data of the device.

Disk Information						
Disk No.	Total Size	Used Size	Free space	Utilization	Remove	Format
Disk0	1862.852	2.841	1860.010	0%	<input type="button" value="Remove"/>	<input type="button" value="Format"/>

Figure 4-20

- **Disk information:** Indicates the capacity of the SD card inserted and allows you to format the SD card. To safely remove the inserted SD card, click **Remove**.

4.5.3 User Account

You can change the Administrator's login name and password. To remain logged in after reboot, select **Disable auto logout after reboot**.

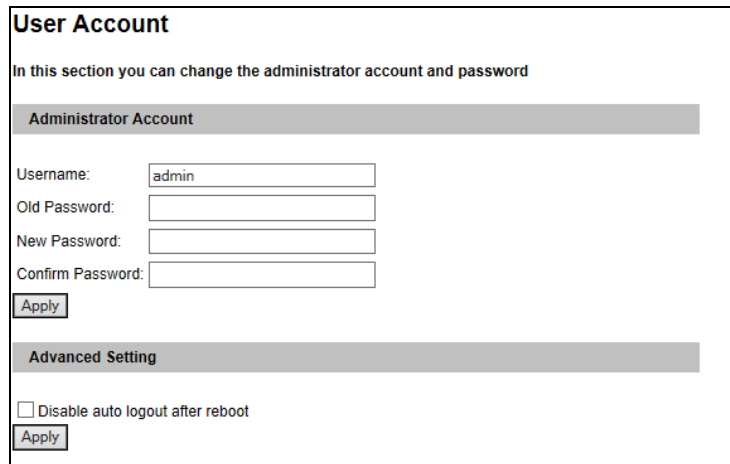

The screenshot shows a web interface titled "User Account". Below the title is a subtitle: "In this section you can change the administrator account and password". The interface is divided into two sections by horizontal bars. The first section is "Administrator Account" and contains four input fields: "Username:" with the value "admin", "Old Password:", "New Password:", and "Confirm Password:". Below these fields is an "Apply" button. The second section is "Advanced Setting" and contains a checkbox labeled "Disable auto logout after reboot" which is currently unchecked. Below this checkbox is another "Apply" button.

Figure 4-21

4.5.4 Log Information

The log information contains dump data that is used by service personnel for analyzing problems.

4.5.5 Tools

You can use additional tools to execute certain system operations and view the firmware version.

Additional Tools

In this section you can set the additional tools

Host Settings

In this section you can determine a hostname and camera name for identification.

Host Name

Auto Reboot Setup

In this section you can set the system's auto reboot time.

Enable

Day Interval days

RebootTime :

Firmware Update

In this section you can see firmware version.

System Settings

Restore to factory default settings

Restore to factory default settings(Except network)

Internal Temperature

Internal Temperature Normal Range: 0°C ~ 95°C "(32°F ~ 203°F)"

Reboot

Do you wish to reboot now?

Figure 4-22

[Host Settings] Enter a descriptive name for GV-CS1320.

[Auto Reboot Setup] Select **Enable** to activate automatic reboot and specify the time for reboot in the sub fields.

- **Day Interval:** Type the day interval between each automatic reboot.
- **Reboot Time:** Use the dropdown lists to specify the time for automatic reboot.

[Firmware Update] Displays the firmware version of GV-CS1320.

[System Settings]

Clicking the first **Load Default** button will restore GV-CS1320 to factory default settings.

Clicking the second **Load Default** button will restore GV-CS1320 to factory default settings (Except network).

Note: After clicking the first default function, you will need to configure the camera access controller's network setting again.

[Internal Temperature] Displays the chipset temperature inside GV-CS1320.

[Reboot] Click the **Reboot** button will make GV-CS1320 perform the software reset.

4.5.6 Language

You can select the language for the Web interface. By default, the language on the Web interface will be the same with the one used for the operating system.

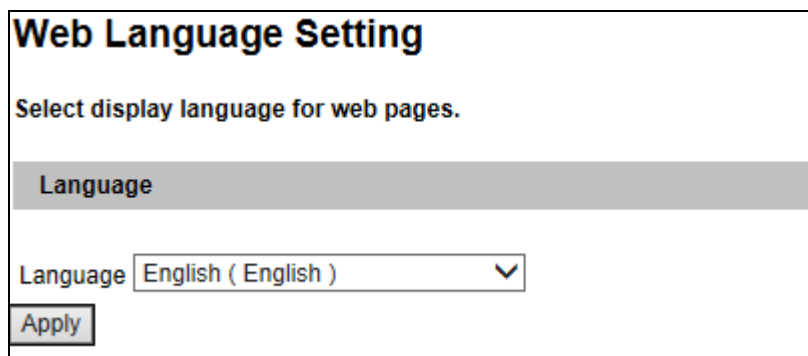

The screenshot shows a web interface titled "Web Language Setting". Below the title is the instruction "Select display language for web pages." There is a section header "Language" in a grey bar. Below this is a dropdown menu labeled "Language" with "English (English)" selected. At the bottom left of the form is an "Apply" button.

Figure 4-23

4.6 SIP

SIP (Session Initiation Protocol) is an IP telephony signaling protocol for Voice over Internet Protocol (VoIP) calls. You can connect to a SIP server and configure VoIP services on the setting page. GV-CS1320 can then place a call to the operator with an IP phone or a computer with VoIP software. Through VoIP, the operator can communication with the visitor and enter an access code to open the door.

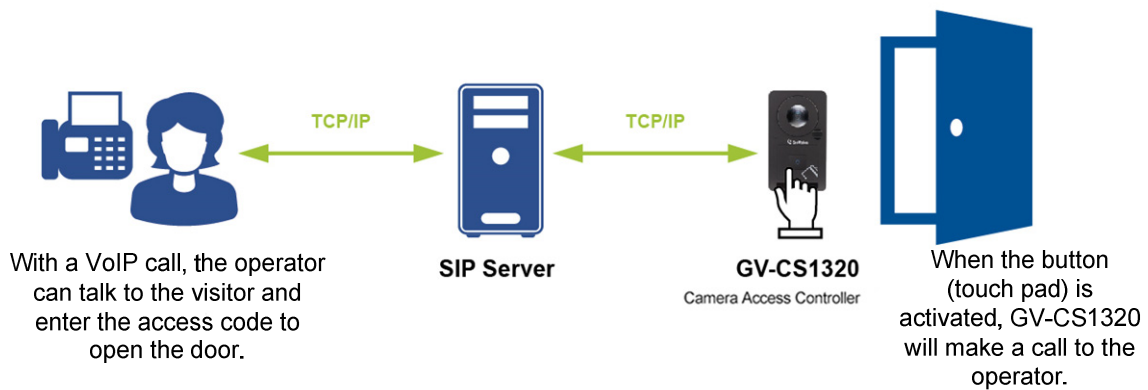

Figure 4-24

Note: SIP is supported by GV-CS1320 V1.11 or later.

SIP

SIP Setting.

Enable

SIP Server Setting

User Name:

Password:

SIP Server Address:

SIP Server Port:

UDP TCP TLS

SIP Outgoing Call Setting

Enable Alternate

Primary Outgoing Call SIP Name: (Extension)

Alternate Outgoing Call SIP Name:

Alternate Outgoing Call SIP Name:

SIP Incoming Call Setting

Decline

SIP Video Setting

Enable Video

SIP Access Code

Enable Access Code

Access Code: (Maximum 4 digits)

Figure 4-25

[SIP Server Setting]

Select **Enable** to apply the following setting:

- **User Name:** Type the phone number of GV-CS1320 registered on SIP Server.
- **Password:** Type the password of GV-CS1320 registered on SIP Server.
- **SIP Server Address:** Type the IP Address of SIP Server.
- **SIP Server Port:** Type the SIP Server's port number or keep the default value 5060.
The default port type is UDP. Change the port type if necessary.

[SIP Outgoing Call Setting]

Select **Enable Alternate** to allow GV-CS1320 to make phone calls to at most three phone numbers registered on SIP server. If unanswered, GV-CS1320 will automatically forward the call to the next two phone numbers.

- **Primary Outgoing Call SIP Name:** Type the first phone number for GV-CS1320 to call.
- **Alternate Outgoing Call SIP Name:** Type the second phone number for GV-CS1320 to call.
- **Alternate Outgoing Call SIP Name:** Type the third phone number for GV-CS1320 to call.

[SIP Incoming Call Setting]

Select **Decline** to reject phone calls from SIP server to GV-CS1320. It indicates that the operator cannot talk to the visitor.

[SIP Video Setting]

Click **Enable Video** to receive video calls so the operator / phone call receiver can watch video streaming of GV-CS1320.

[SIP Access Code]

Click **Enable Access Code** so that the operator / phone call receiver of GV-CS1320 can take the phone call and enter the access code to open the door.

- **Access Code:** Type at most 4 digits to be the access code of the door.

Chapter 5 Advanced Applications

This chapter introduces more advanced applications.

5.1 Upgrading System Firmware

GeoVision periodically releases the updated firmware on the website. The new firmware can be simply loaded into GV-CS1320 using its Web interface or GV-IP Device Utility download from GeoVision's [website](#).

Important Notes before You Start

Before you start updating the firmware, please read these important notes:

1. Stop the connection to GV-DVR / NVR / VMS.
2. Stop all the remote connections, including RTSP.
3. While the firmware is being updated, the power supply and network connection must not be interrupted.

WARNING: The interruption of power supply during updating causes not only update failures but also damages to your camera access controller. In this case, please contact your sales representative and send your device back to GeoVision for repair.

4. If firmware upgrade fails, you will need to restore GV-CS1320 to the default settings. For details, see *5.3 Restoring to Factory Default Settings* in the User's Manual.

5.1.1 Using the Web Interface

1. In the Live View window, click the **Show System Menu** button (No. 8, Figure 3-4) and select **Remote Config**. This dialog box appears.

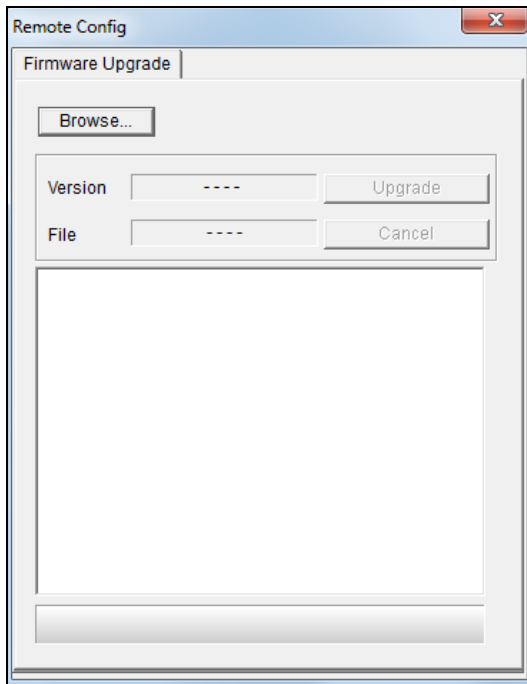



Figure 5-1

2. Click the **Browse** button to locate the firmware file (.img) saved at your local computer.
3. Click the **Upgrade** button to process the upgrade.

5.1.2 Using the IP Device Utility

GV-IP Device Utility provides a direct way to upgrade the firmware for multiple IP devices. Note the computer used to upgrade firmware must be under the same network as the IP devices.

1. Download and install GV-IP Device Utility from our [website](#).
2. On the GV-IP Utility window, click the  button to search for the IP devices connected under the same LAN. Click the **Name** or **Mac Address** column to sort.
3. Double-click a GV-CS1320 in the list to bring up a dialog box, and click the **Firmware Upgrade** tab. This dialog box appears.

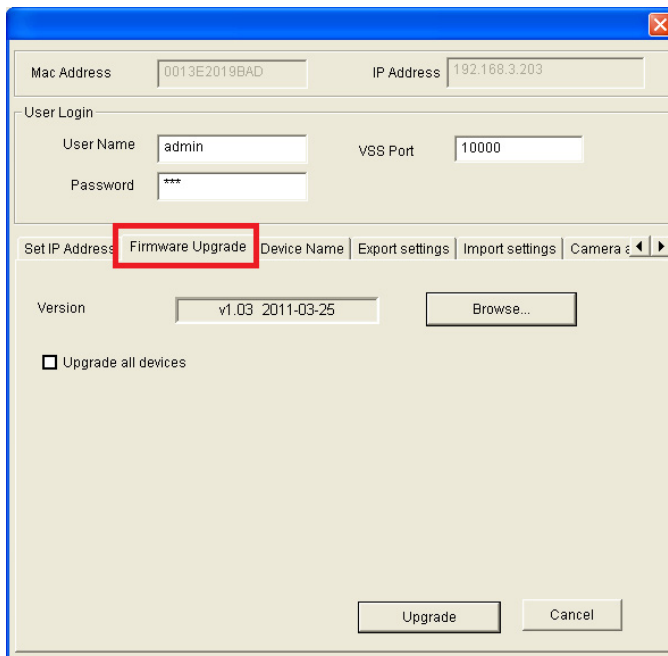

Figure 5-2

4. Click the **Browse** button to locate the firmware file (.img) saved at your local computer.
5. If you would like to upgrade all cameras / camera access controllers of the same model in the list, check **Upgrade all devices**.
6. Type **Password**, and click **Upgrade** to process the upgrade.

5.2 Backing Up and Restoring Settings

With GV-IP Device Utility, you can back up the configurations in GV-CS1320, and restore the backup data to the current unit or import it to another unit.

5.2.1 Backing Up the Settings

1. Run GV-IP Device Utility and locate a GV-CS1320. See Steps 1-2 in *5.1.2 Using the IP Device Utility*.
2. Double-click a GV-CS1320 in the list to bring up a dialog box, and click the **Export Settings** tab. This dialog box appears.

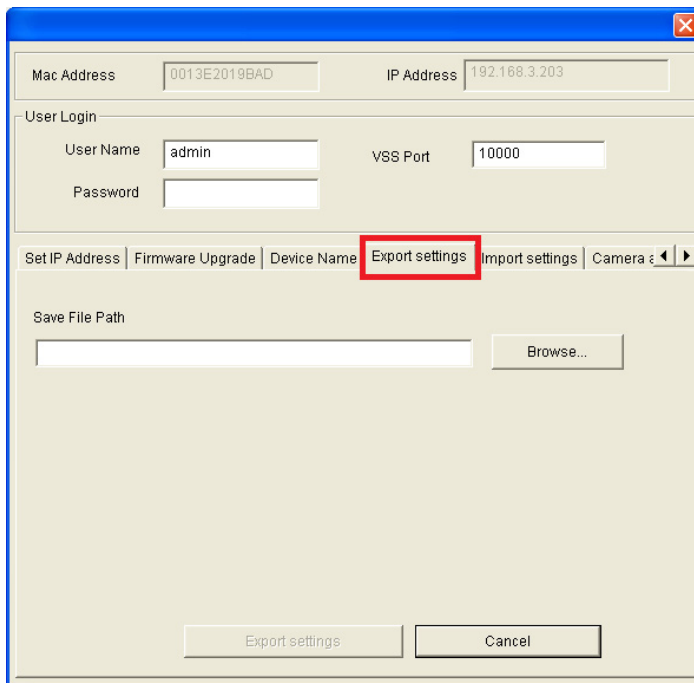

Figure 5-3

3. Click the **Browse** button to assign a file path.
4. Type the **Password**, and click **Export Settings** to save the backup file.

5.2.2 Restoring the Settings

1. In Figure 5-3, click the **Import Settings** tab. This dialog box appears.

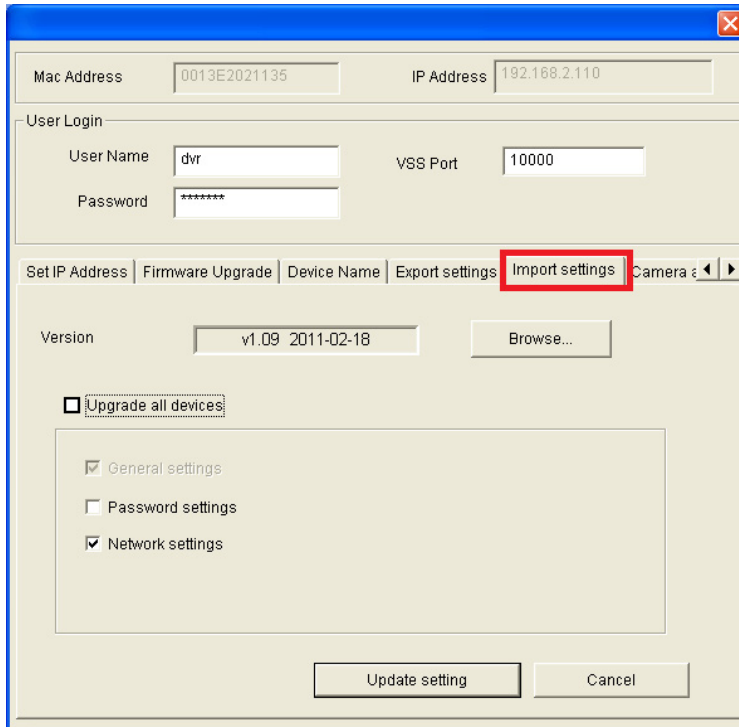

Figure 5-4

2. Click the **Browse** button to locate the exported file (.dat).
3. Select **Upgrade all devices** to apply the settings to all devices of the same model in the same LAN. To import password settings and/or network settings, select **Password Settings** and/or **Network settings**.
4. Click the **Update Settings** button to start restoring.

5.3 Restoring to Factory Default Settings

You can restore GV-CS1320 to factory default settings using the Web interface or directly on the camera.

To restore to default settings using the Web interface:

1. In the left menu, select **Management** and select **Tools**.
2. Under the **System Settings** section, click the **Load Default** button.

To restore to default settings directly on the camera access controller:

1. Unplug the power cable.
2. Use a pointy object such as the tip of a pen to hold down the **Load default** button (No. 7, Figure 1-3) while plugging the power cable.
3. Wait until the status LED blinks twice to release the **Load default** button. The process takes about 5 seconds.

5.4 Verifying Watermark

The watermark is an encrypted and digital signature embedded in the video stream during the compression stage, protecting the video from the moment of its creation. Watermarking ensures that an image is not edited or damaged after it is recorded. To enable the watermark function, see [Watermark], *4.1.1 Video Settings*.

The **Watermark Proof** is a watermark-checking program. It can verify the authenticity of the recording before you present it in court.

5.4.1 Accessing AVI Files

To verify watermark, first you have to access the recorded AVI files by one of these methods:

1. Use the **File Save** function on the Live View window (No. 6, Figure 3-4) to start recording on the local computer.

5.4.2 Running Watermark Proof

1. Install **Watermark Proof** from the Software DVD. After installation, a **WMProof** icon is created on your desktop.
2. Double-click the created icon. The Water Mark Proof window appears.
3. Click **File** from the menu bar and select **Open** and locate the recording (.avi). The selected recording is then listed on the window. Alternatively, you can drag the recording directly from the storage folder to the window.
4. If the recording is unmodified, a check will appear in the **Pass** column. On the contrary, if the recording is modified or does not contain watermark during recording, a check mark will appear in the **Failed** column. To review the recording, double-click the listed file on the window.

5.4.3 The Watermark Proof Window

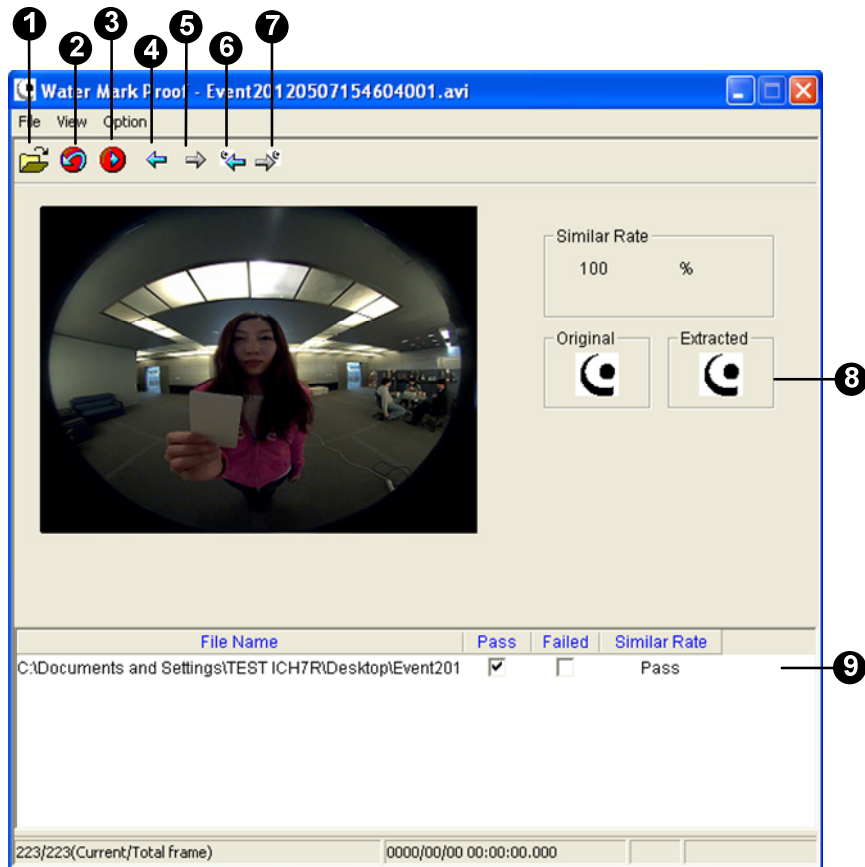

Figure 5-5

The controls in the window:

No.	Name	Description
1	Open File	Opens the recorded file.
2	First Frame	Goes to the first frame of the file.
3	Play	Plays the file.
4	Previous Frame	Goes to the previous frame of the file.
5	Next Frame	Goes to the next frame of the file.
6	Previous Watermarked Frame	Goes to the previous frame that contains watermark.
7	Next Watermarked Frame	Goes to the next frame that contains watermark.
8	Original vs. Extracted	The Extracted icon should be identical to the Original icon. If not, it indicates the recording has been tampered with.
9	File List	Displays the proof results.

Chapter 6 GV-DVR / NVR / VMS Configurations

GV-DVR / NVR / VMS provide a complete video management, such as video viewing, recording, playback, alert settings and more. The integration specifications are listed below:

1. GV-CS1320 is compatible with GV-DVR / NVR V8.6.2.0 with patch or later.
2. GV-CS1320 is compatible with GV-VMS V15.10.
3. The maximum number of streams supported by GV-CS1320 is **5**. When GV-CS1320 is connected to IE browser or any other applications, it takes up **1** stream. When GV-CS1320 is connected to GV-DVR / NVR / GV-VMS, it takes up **2** streams.

Maximum number of streams	5
Connection from one GV-DVR / NVR / VMS	Takes up 2 streams
Connection to one GV-ASManager	Takes up 2 streams
One connection to Web interface	Takes up 1 stream

Note:

1. The above maximum numbers of streams are based on the maximum resolution for the camera access controller and the codec H.264.
2. By default, GV-CS1320 is in dual streams and will take up 2 streams when connected to GV-DVR / NVR / GV-VMS.

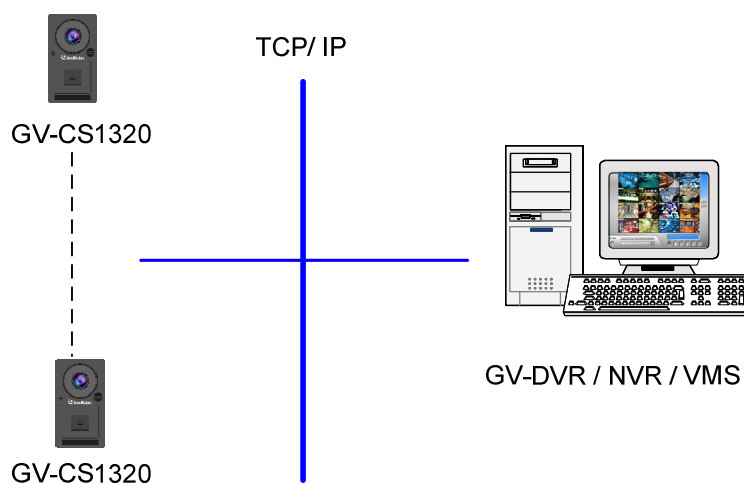

Figure 6-1

6.1 Setting up GV-CS1320 on GV-DVR / NVR

To set up GV-CS1320 and receive live view on GV-DVR / NVR, follow these steps:

1. On the main screen, click the **Configure** button, select **System Configure**, select **Camera Install** and click **IP Camera Install**. This dialog box appears.

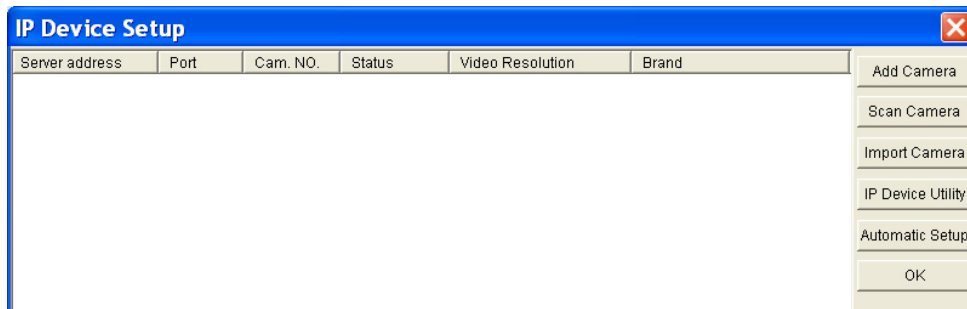

Figure 6-2

- To automatically set up GV-CS1320, click **Scan Camera** to detect any GV-IP devices on the LAN.
- To manually set up GV-CS1320, click **Add Camera**. Follow steps 2 to 7.

2. Click **Add Camera**. This dialog box appears.

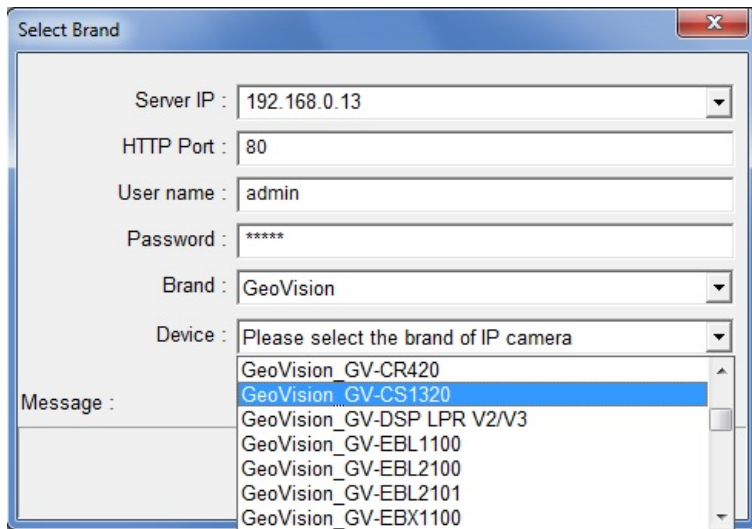

Figure 6-3

3. Type the IP address, username and password of GV-CS1320. Modify the default HTTP port if necessary. Select **GeoVision** from the **Brand** dropdown list and select the model from the **Device** dropdown list. This dialog box appears.

6 GV-DVR / NVR / VMS Configurations

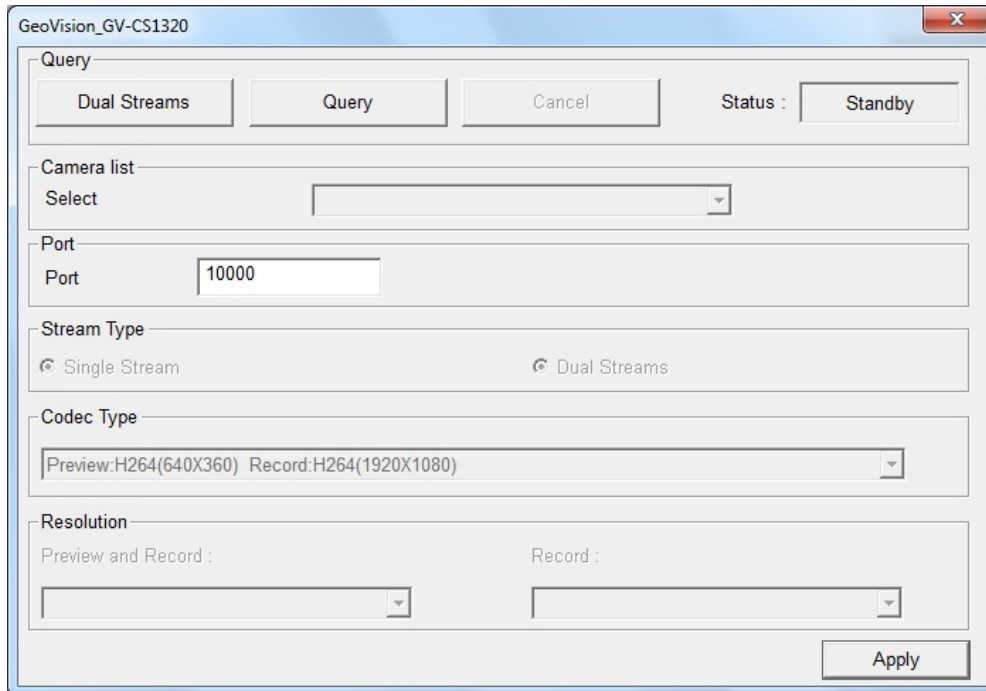

Figure 6-4

4. Click **Query** to acquire the information from GV-CS1320. The video streaming port should match the VSS port on GV-CS1320. The default port number is 10000.
5. Click **Apply**. GV-CS1320 is added to the connection list.
6. Click the listed camera access controller and select **Display position** to map the IP camera access controller to a channel on GV-DVR / NVR.

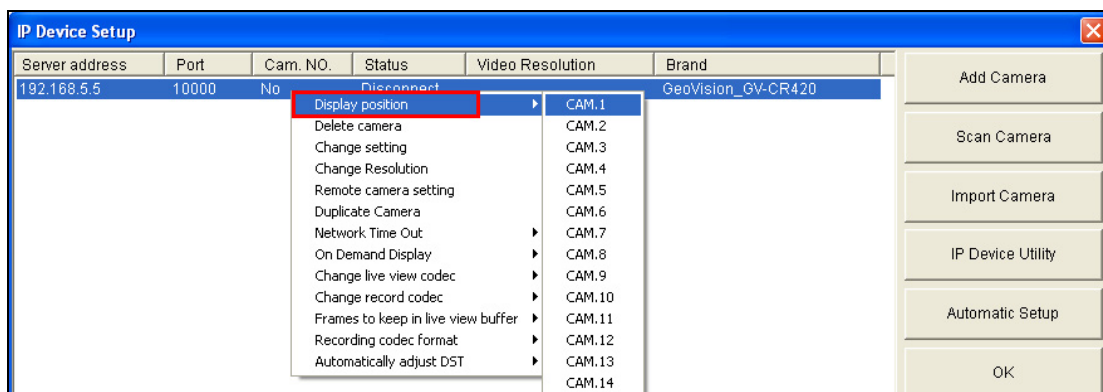

Figure 6-5

7. The Status column should display "Connected". Click **OK**.

6.1.1 Customizing the Basic Settings

After GV-CS1320 is connected and assigned with a display position, you can configure GV-CS1320's settings such as frame rate, codec type and resolution. Right-click the desired camera access controller to see the following list of options:

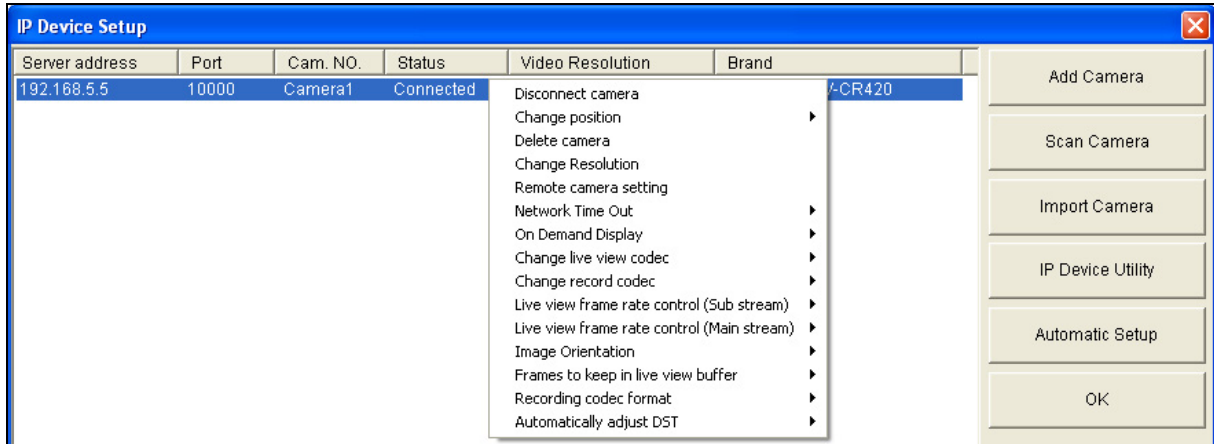

Figure 6-6

- **Remote Camera Setting:** Accesses the configuration interface of the connected device.
- **Network Time Out:** When network disconnection exceeds the specified time period, the camera status will be displayed as Connection Lost.
- **On Demand Display:** Enable automatic adjustment of live view resolution. Refer to the *On Demand Display* section in *DVR User's Manual* for more details.
- **Change live view codec:** Changes the code type of the live view.
- **Change record codec:** Change the codec type to record in.
- **Live view frame rate control (Sub stream):** Sets the live view of the sub stream to help reduce the CPU usage. If you have set the live view codec to be MJPEG, select the number of frames to allow in a second. If the live view codec selected is H.264, select one of the following options:
 - ⊙ **Maximum Live-view Frame Rate:** View the video at the maximum frame rate possible.
 - ⊙ **Live-view Key Frame only:** You can choose to view the key frames of the videos only instead of all frames on the live view. This option is related to the GOP setting of the IP camera. For example, if the GOP value is set to 30, there is only one key frame among 30 frames.

- **Live view frame rate control (Main stream):** Sets the live view frame rate of the main stream with higher resolution when On Demand function is enabled. Refer to the sub stream setting above to see the options available.
- **Image Orientation:** You can adjust the image orientation by selecting **Normal**, **Horizontal Mirror**, **Vertical Flip** or **Rotate 180°**.
- **Frames to keep in live view buffer:** Specifies the number of frames to keep in the live view buffer.
- **Recording Codec Format:** Specifies whether to record in standard or GeoVision type of MJPEG H.264 codec.
- **Automatically Adjust DST:** If enabled, the time on the GV-IP device Web interface will be synchronized with the time of GV-DVR / NVR when DST period starts or ends on the GV-DVR / NVR.

6.2 Setting up GV-CS1320 on GV-VMS

Follow the steps below to manually connect your GV-CS1320 to GV-VMS.

1. To access the IP Device Setup page, click **Home** , select **Toolbar** , click **Configure**  and select **Camera Install**.

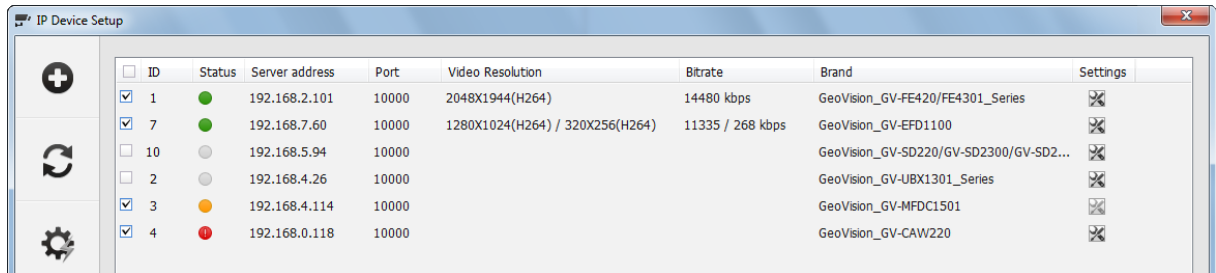

Figure 6-7

2. Click **Add Camera** . This dialog box appears.

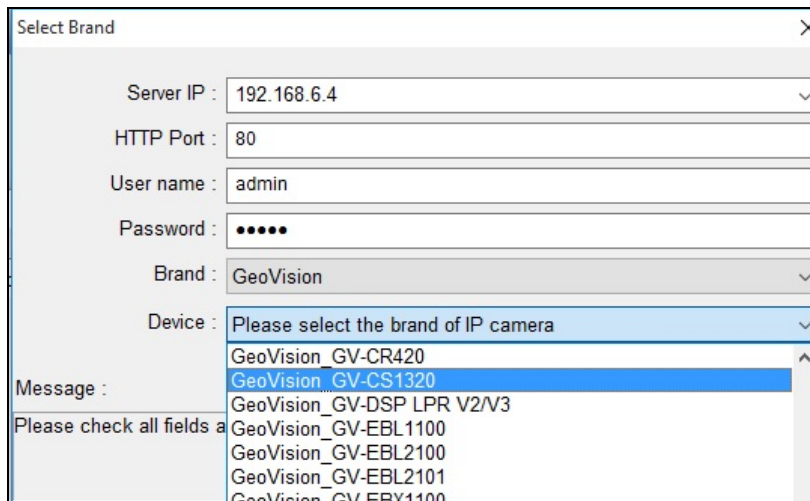

Figure 6-8

6 GV-DVR / NVR / VMS Configurations

3. Type the IP address, username and password of GV-CS1320. Modify the default HTTP port **80** if necessary.
4. Select GeoVision and model name from the **Brand** dropdown list and select GV-CS1320 from the **Device** dropdown lists. This dialog box appears.

The dialog box is titled "GeoVision_GV-CS1320". It features a "Query" section with buttons for "Dual Streams", "Query", and "Cancel", along with a "Status" dropdown menu currently set to "Standby". Below this is a "Camera list" section with a "Select" dropdown. The "Port" section has a text input field containing "10000". The "Stream Type" section has two radio buttons: "Single Stream" and "Dual Streams", with "Dual Streams" selected. The "Codec Type" section has a dropdown menu showing "Preview:H264(640X360) Record:H264(1920X1080)". The "Resolution" section has two dropdown menus for "Preview and Record" and "Record". An "Apply" button is located at the bottom right of the dialog.

Figure 6-9

5. In the dialog box, configure the options.
 - **Dual Streams:** Select this option to apply the dual-streaming settings (lower resolution for live view and higher resolution for recording).
 - **Query:** Detect and apply the current codec and resolution setting on GV-CS1320.
 - **Port:** Modify the video streaming port number if necessary.
6. Click **Apply** to add GV-CS1320 to the list.
7. To connect the added GV-CS1320, click the box besides the **ID** column. Upon successful connection, the **Status** icon shows green, with the video resolution and bit rate being displayed in the correspondent columns.

ID	Status	Server address	Port	Video Resolution	Bitrate	Brand	Settings
1		192.168.6.4	10000	1920X1080(H264) / 640X360(H264)	1317 / 331 kbps	GeoVision_GV-CS1320	

Figure 6-10

Chapter 7 Mobile Phone Connection

Using iPhone, iPod Touch, iPad or Android Smartphones, you can now remotely watch live view with GV-CS1320. Find **GV-Access** App from our [website](#) for latest information.

Chapter 8 Connecting to GV-I/O Box 4 Ports

Ports

GV-I/O Box 4 Ports provides extra protection for GV-CS1320. The wiring of a locking device to be secured inside the door can prevent outside intruders from shorting the wires together and opening the door.

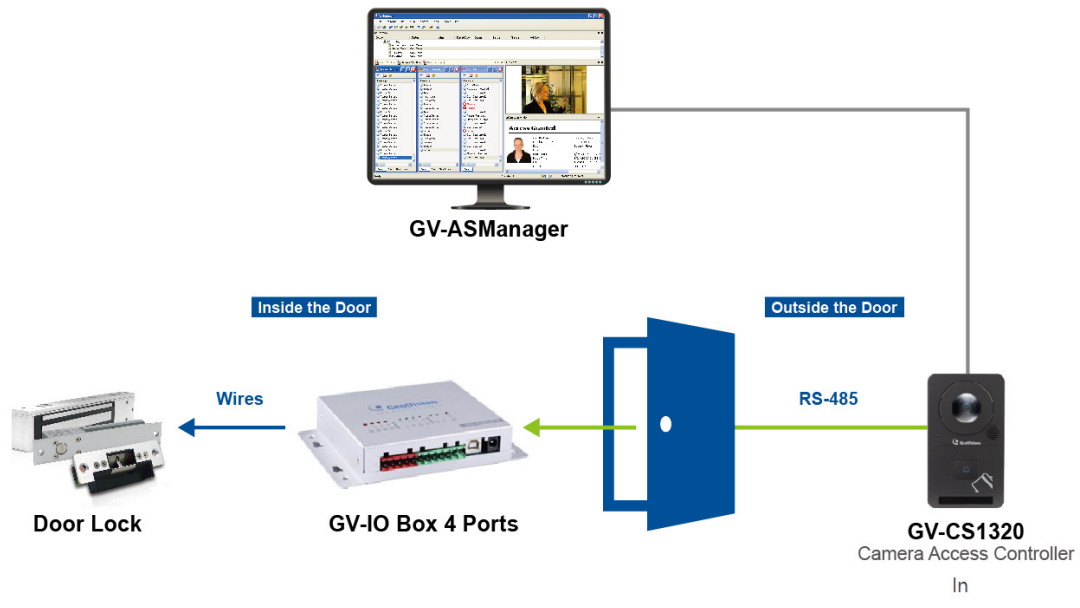

Figure 8-1

8.1 Physical Connection

Connect the RS-485 wires from GV-CS1320 to GV-I/O Box 4 Ports.

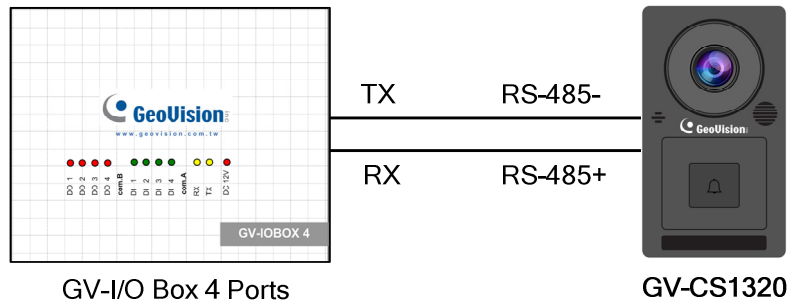

Figure 8-2

The table below shows the wire assignments of RS-485 connection on GV-CS1320.

Wire color	Definition	Wire color	Definition
Red	12V DC	Blue	RS-485 +
Black	GND	Light Blue	RS-485 -

For GV-I/O Box 4 Ports, four Door Entry / Exit Control related functions such as Door Sensor, Door / Gate Button, Fire Sensor, and Tamper Sensor are available for users. The table below specifies the corresponding input and output pins for each function.

GV-I/O Box wiring

Sensor / Button	Input Pins on GV-I/O Box	Output Pins on GV-I/O Box
Door Sensor	Input 1	(to trigger) Output 2
Door / Gate Button	Input 2	(to trigger) Output 1
Fire Sensor	Input 3	(to trigger) Output 2
Tamper Sensor	Input 4	(to trigger) Output 2
Door Bell (Touchpad)	X	(to trigger) Output 3

Note:

- The pin of Output 1 is for opening the door, Output 2 for sending the alarm and Output 3 for triggering the door bell. The pin of Output 4 on I/O Box is not functional in the application.
- GV-I/O Box 8 Ports and GV-I/O Box 16 Ports are not supported.
- When GV-I/O Box 4 Ports is properly installed in the application, the door sensor (yellow) and door button (light red) wires of GV-CS1320 will no longer be effective.

8.2 Setting up GV-CS1320

After establishing connections among GV-CS1320, GV-I/O Box, door button and sensors, you need to set up GV-CS1320 to identify all these connected input devices.

1. Log on the Web interface of GV-CS1320.
2. Under **Access Control**, select **Extended IOBOX Configuration** to access the Input and Output settings of GV-I/O Box.

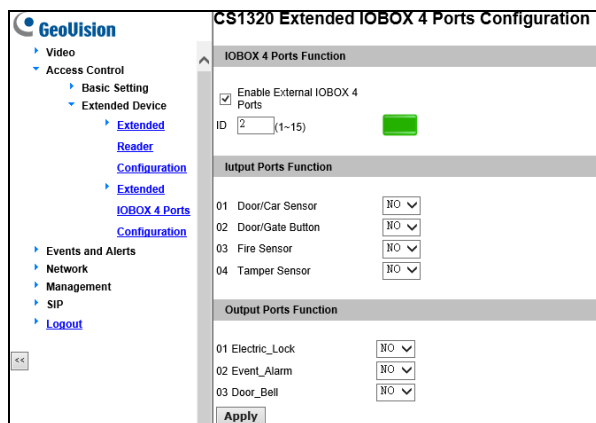

Figure 8-3

All input and output devices are **dry contact** and can be configured as normally open (NO) or normally closed (NC) on the configuration page.

[IOBOX 4 Ports Function]

- **External IOBOX:** activate the external I/O box.
- **ID:** Type the ID set on GV-I/O Box.

[Input Ports Function]

- **Door / Car Sensor:** When the door is forcibly opened, **Door Sensor** will trigger **Forced Open**. If **Forced Open** is selected on GV-ASManager, GV-CS1320 will send forth alarm sound.
- **Door / Gate Button:** When **Door / Gate Button** gets triggered, the door will be opened.
- **Fire Sensor:** When the flame detector senses fire, **Fire Sensor** will be triggered. If **Fire Alarm** is selected on GV-ASManager, GV-CS1320 will send forth alarm sound.
- **Tamper Sensor:** When GV-CS1320 is being physically tampered with, the alarm events will show on GV-ASManager. If **Tamper** is selected on GV-ASManager, GV-CS1320 will send forth alarm sound.

Note: For the alarm sound to be sent by GV-CS1320, the corresponding settings must be specified on GV-ASManager first.

[Output Ports Function]

- **Electric Lock:** The lock output is triggered when the correct card is presented to open the locking device.
- **Event Alarm:** The alarm output is triggered when the defined alarm events occur.

Inputs	Alarm Events
Door Sensor	Forced Open
Fire Sensor	Fire Alarm
Tamper Sensor	Tamper

- **Door Bell:** The door bell is triggered upon activating the touchpad.
3. Click **Apply**. The green light represents the active connection between GV-CS1320 and GV-I/O Box whereas a red light indicates otherwise.

Note:

1. GV-I/O Box application is only supported by the Authentication Mode of Door Entry and Exit Control. Parking and Elevator Control related functions are not supported.

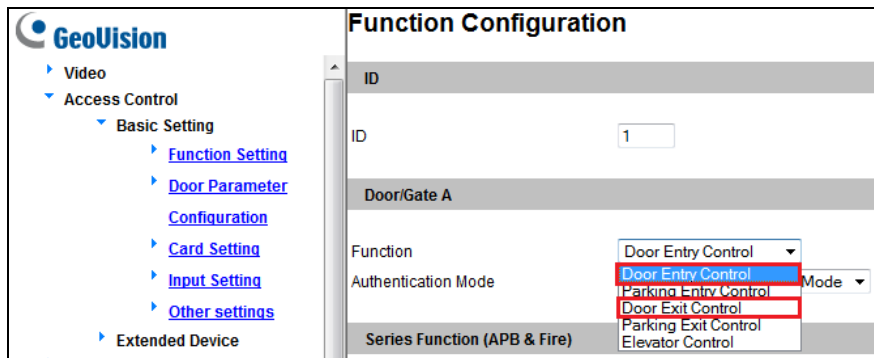

2. GV-I/O Box 4 Ports is supported by GV-CS1320 firmware V1.11 or later.
-

Appendix

A. RTSP Protocol Support

The camera reader can support RTSP protocol for both video and audio streaming.

If you are using Quick Time player, use the following RTSP command:

```
rtsp://<IP of the camera reader>:8554/<CH No.>.sdp
```

For example, `rtsp://192.168.3.111:8554/CH001.sdp`

If you are using VLC player, use the following RTSP command:

```
rtsp://<ID>:<Password>@<IP of the camera reader>:8554/<CH No.>.sdp
```

For example, `rtsp://admin:admin@192.168.3.111:8554/CH001.sdp`

Note:

1. RTSP streaming is supported over HTTP, UDP and TCP.
 2. The RTSP protocol must be enabled on the Web interface. See 4.3.8 RTSP.
 3. Only VLC and QuickTime players are supported for streaming video via RTSP protocol.
-

B. The CGI Command

You can use the CGI command to obtain a snapshot of the live view without logging in the Web interface or to access the User Account Web interface. For a camera reader with the following details:

IP address: 192.168.2.11

Username: admin

Password: admin

Desired stream: 1

Type the following into your web browser to **obtain a snapshot**:

```
http://192.168.2.11/PictureCatch.cgi?username=admin&password=admin&channel=1
```

Type the following into your web browser to **access the User Account Web interface**:

```
http://192.168.2.11/ConfigPage.cgi?username=admin&password=admin&page=UserSetting
```