



WayPoint102

DC Outdoor Power Supply/Charger

Installation Guide



Rev. 083018

More than just power.™

Installing Company: _____ Service Rep. Name: _____

Address: _____ Phone #: _____

Overview:

Altronix WayPoint102 DC Outdoor Power Supply/Charger provides 12VDC and is designed to be conveniently located where power is required.

Specifications:

Input:

- Input: 120VAC, 60Hz, 3.5A.
- Input fuse rating: 5A/250V.

Output:

- 12VDC @ 10A maximum supply current.
- Auxiliary power-limited output rated @ 1A (unswitched).
- Filtered and electronically regulated output.
- Thermal overload and short circuit protection.

Battery Backup:

- Built-in charger for sealed lead acid or gel type batteries.
- Maximum charge current 1.54A.
- Automatic switch over to stand-by battery.

Output Disconnect:

- Supervised output disconnect (latching or non-latching) 10K EOL resistor. Operates on a normally open (NO) or normally closed (NC) trigger.

Supervision:

- AC fail supervision (form "C" contacts).
- Battery fail & presence supervision (form "C" contacts).
- Low power shutdown. Shuts down DC output terminals if battery voltage drops below 71-73%. Prevents deep battery discharge.

Visual Indicators:

- Green AC Power LED indicates 120VAC present.
- AC input and DC output LED indicators.

Environmental:

- Operating Ambient Temperature:
 - 40°C to 60°C (– 40°F to 140°F).
- Relative Humidity: 85%, +/- 5%
- Storage Temperature:
 - 40°C to 75°C (– 40°F to 167°F).
- Operating Altitude: – 304.8 to 2,000m.

Optional Accessories:

- **PMK1 Pole Mount Kit** simplifies installation of outdoor units.
- **LINQ2 Network Communication Module** provides remote supervision, control, and monitoring over LAN/WAN.

Enclosure:

- NEMA 4/4X, IP66-11 Rated enclosure for outdoor use.
- Enclosure Dimensions (H x W x D approx.): 13.31" x 11.31" x 5.59" (338.1 mm x 287.3 mm x 142 mm).
- Enclosure accommodates up to two (2) 12VDC/7AH batteries.

Installation Instructions:

Unit shall be installed in accordance with The National Electrical Code and all applicable Local Regulations.

1. Remove backplane from enclosure prior to mounting (do not discard hardware).
2. Mark and drill desired inlets on the enclosure to facilitate wiring (*Fig. 2, pg. 4*).

Note: Inlets for conduit fittings should only be made on the bottom of the enclosure.

UL Listed NEMA type 4X rated conduit connector/hubs shall be used for the appropriate size inlets.

3. Mount unit in the desired location. For wall mounting refer to *Fig. 4, pg. 7*.
For pole mounting installation refer to *pg. 7 - Pole Mounting Using Optional Pole Mount Kit PMK1*.
4. Mount backplane to enclosure with hardware.
5. To facilitate wire entry utilize weather-tight NEMA 4 rated connectors, bushings, and cable.
6. Connect unswitched AC power (120VAC, 60 Hz) to terminals marked [L, N] (*Fig. 3, pg. 5*).
Green branch wire connects to earth (safety) ground lug .
Wire gauge range of connectors is 14 AWG to 11 AWG (1.6mm to 2.5mm diameter).
7. Measure output voltage before connecting devices. This helps avoiding potential damage.
8. Connect devices to be powered to terminals marked [– DC +] (*Fig. 1h, pg. 4*). For auxiliary device connection this output will not be affected by Low Power Disconnect or Output Disconnect.
Connect device to terminals marked [+ AUX –] (*Fig. 1f, pg. 4*).
9. For Access Control applications batteries are optional. When batteries are not used, a loss of AC will result in the loss of the output voltage. When the use of stand-by batteries is desired, they must be lead acid or gel type. Connect battery to terminals marked [– BAT +] (*Fig. 1g, pg. 4*). Use batteries - Casil CL1270 (12V/7AH) batteries or UL recognized BAZR2 batteries of an appropriate rating.
10. Connect appropriate signaling notification devices to AC FAIL & BAT FAIL (*Fig. 1b, pg. 4*) supervisory relay outputs.

11. To delay AC reporting for 2 hrs. set DIP switch [AC Delay] to OFF position (*Fig. 1c, pg. 4*).
To delay AC reporting for 1 min. set DIP switch [AC Delay] to ON position (*Fig. 1c, pg. 4*).
12. To enable Output Disconnect set DIP switch [Shutdown] to ON position (*Fig. 1c, pg. 4*).
To disable Output Disconnect set DIP switch [Shutdown] to OFF position (*Fig. 1c, pg. 4*).
13. Trigger terminals are end of a line resistor supervised (10k ohms). Opening or shorting trigger terminals will cause [DC] output to shutdown (*Fig. 1d, pg. 4*).
14. Place a jumper for non-latching output. A momentary short on these terminals resets output latching [Trigger EOL Shutdown] (*Fig. 1e, pg. 4*).
15. Upon completion of wiring secure enclosure door with latches and optional lock.

WARNING: When installing in a non-restricted service area use lock or other fastened means on door latches. This installation should be made by qualified service personnel and should conform to the National Electrical Code and all local codes.

LED Diagnostics:

Red (DC)	Green (AC/AC1)	Power Supply Status
ON	ON	Normal operating condition.
ON	OFF	Loss of AC. Stand-by battery supplying power.
OFF	ON	No DC output.
OFF	OFF	Loss of AC. Discharged or no stand-by battery. No DC output.

Terminal Identification:

Terminal Legend	Function/Description
L, G, N	Connect 120VAC 60Hz to these terminals: L to hot, N to neutral(non power-limited) (<i>Fig. 1a, pg. 4</i>).
- DC + (<i>Fig. 1h, pg. 4</i>)	12VDC @ 10A continuous output (Non power-limited output).
Trigger EOL Supervised	Trigger inputs can be normally open, normally closed from an output circuit (power-limited input) (<i>Fig. 1d, pg. 4</i>).
NO, GND RESET	Trigger input latching or non-latching (power-limited) (<i>Fig. 1c, pg. 4</i>).
+ AUX -	Auxiliary power-limited output rated @ 1A (unswitched) (power-limited output) (<i>Fig. 1f, pg. 4</i>).
AC Fail NC, C, NO	Indicates loss of AC power, e.g. connect to audible device or alarm panel. Relay normally energized when AC power is present. Contact rating 1A @ 30VDC (power-limited) (<i>Fig. 1b, pg. 4</i>).
Bat Fail NC, C, NO	Indicates low battery condition, e.g. connect to alarm panel. Relay normally energized when DC power is present. Contact rating 1A @ 30VDC. A removed battery is reported within 5 minutes. Battery reconnection is reported within 1 minute (power-limited) (<i>Fig. 1b, pg. 4</i>).
- BAT +	Stand-by battery connections. Maximum charge current 1.54A (non power-limited) (<i>Fig. 1g, pg. 4</i>).

Fig. 1 - eFlow Board Configuration

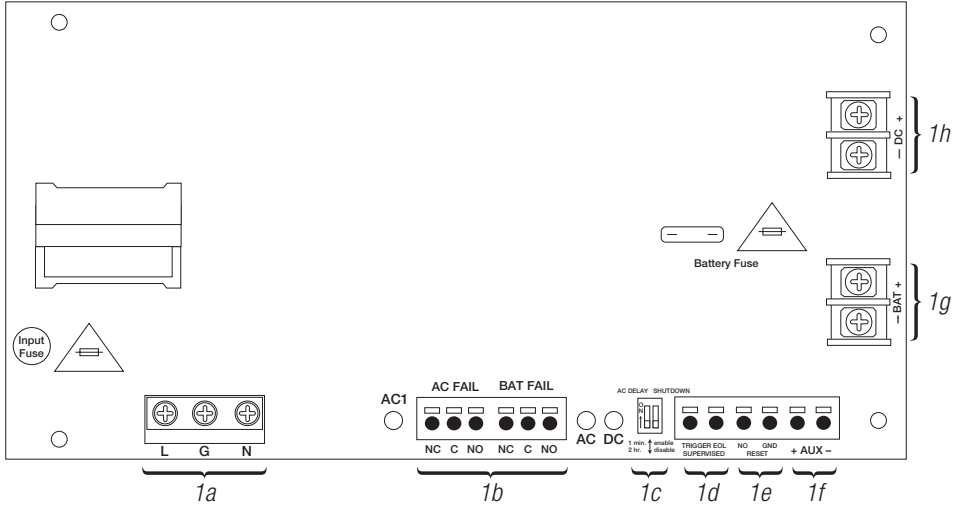

Fig. 2

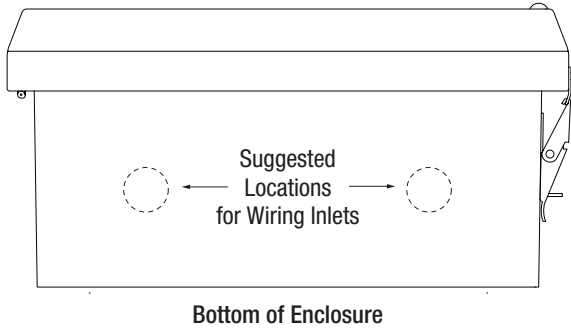
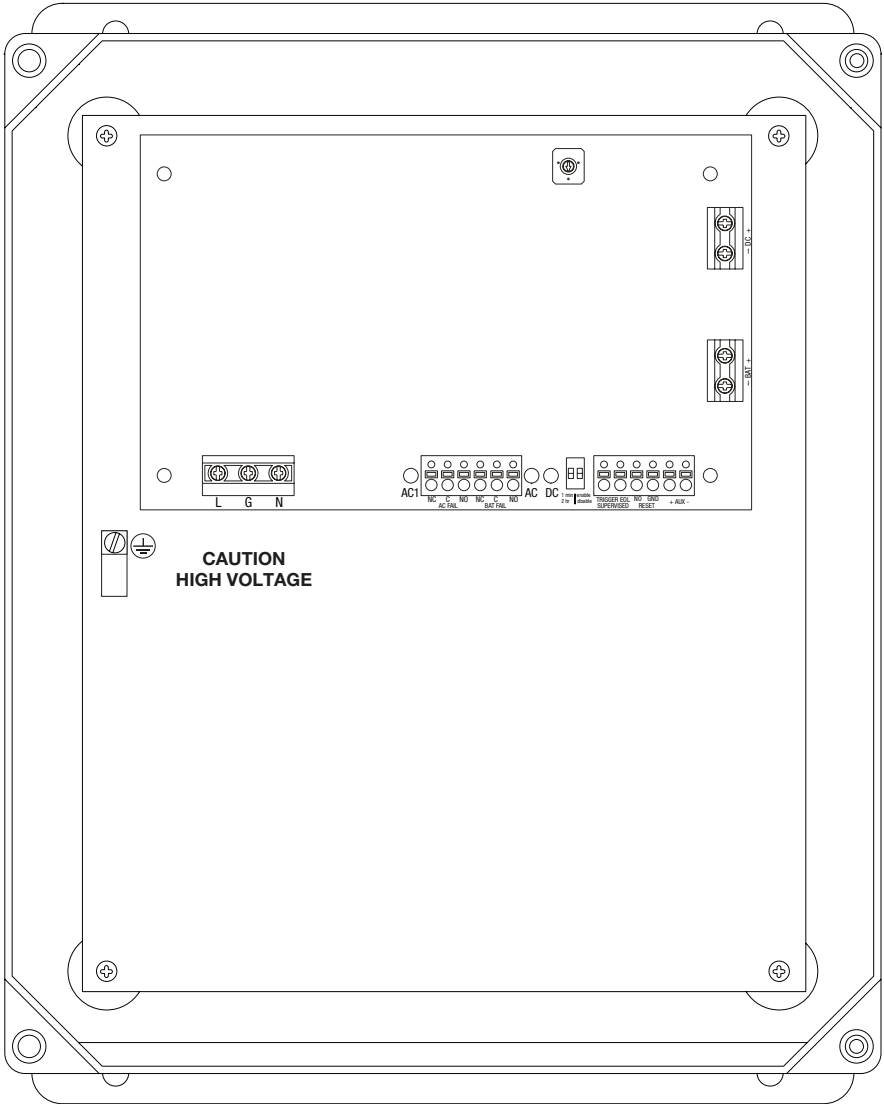

Fig. 3 - WayPoint102



The lightning flash with arrowhead symbol within an equilateral triangle is intended to alert the user to the presence of an insulated DANGEROUS VOLTAGE within the product's enclosure that may be of sufficient magnitude to constitute an electric shock.



The exclamation point within an equilateral triangle is intended to alert the user to the presence of important operating and maintenance (servicing) instructions in the literature accompanying the appliance.



CAUTION
RISK OF ELECTRIC SHOCK
DO NOT OPEN



CAUTION: To reduce the risk of electric shock do not open enclosure. There are no user serviceable parts inside. Refer servicing to qualified service personnel.

Notes:

Wall Mount Installation

- 1- Place unit at desired location and secure with mounting screws (*not included*) (*Fig. 4, pg. 7*).

Fig. 4

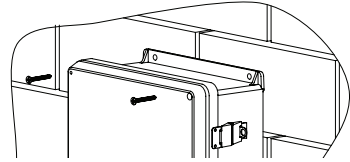

Pole Mounting Using Optional Pole Mount Kit PMK1 (not included):

This installation should be made by qualified service personnel. This product contains no serviceable parts. PMK1 is intended for use with Altronix outdoor rated power supplies or accessories housed in WP1, WP3 and WP4 enclosures. Brackets are designed for use with the Wormgear Quick Release Straps (two included).

1. Thread one (1) wormgear quick release strap through the slots on the back of a mounting bracket (*Fig. 5, pg. 7*).
2. Once the desired height of the top Pole Mount bracket is achieved, tighten the straps down by sliding open end of the strap through the locking mechanism on the strap, then tighten the screw with flat head screwdriver or 5/16" hex socket driver (*Fig. 6, pg. 7 and Fig. 8, pg. 7*).

Fig. 5

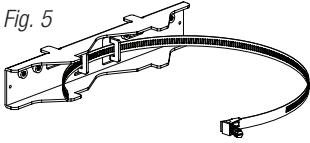

Fig. 6

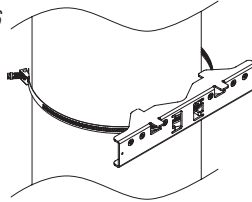
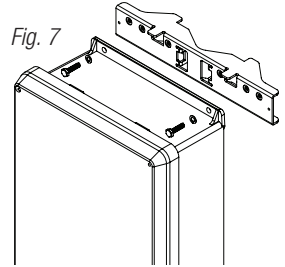

Fig. 7



3. Attach the bottom bracket to the enclosure by inserting bolts through the flange of the enclosure and into the bracket, tightening bolts with a 7/16" hex socket (*Fig. 7, pg. 7*).
4. Thread the second wormgear quick release strap through the slots on the back of the bottom mounting bracket (*Fig. 5, pg. 7*).
5. Mount enclosure onto the top bracket by inserting bolts through flange of the enclosure and into the bracket, tightening bolts with a 7/16" hex socket (*Fig. 7, pg. 7*).
6. Tighten the straps of the bottom bracket down by sliding the open end of the strap through the locking mechanism on the strap, then tighten screw with flat head screwdriver or 5/16" hex socket driver (*Fig. 8, pg. 7*).
7. Clip excess straps.

Fig. 8

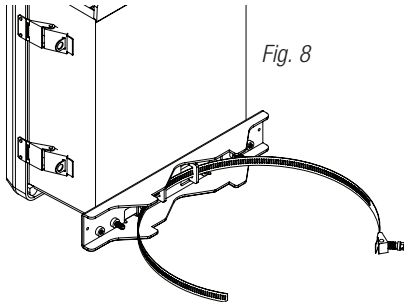

Fig. 9
2" to 8" (50.8mm to 203.2mm)
diameter round pole

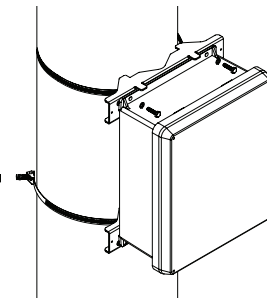
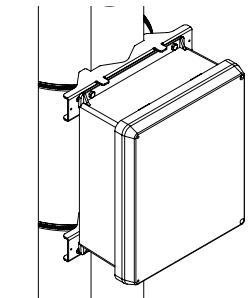

Fig. 9a
5" (127mm) square pole



Enclosure Dimensions (H x W x D approximate):

13.31" x 11.31" x 5.59" (338.1mm x 287.3mm x 142mm)

FRONT VIEW

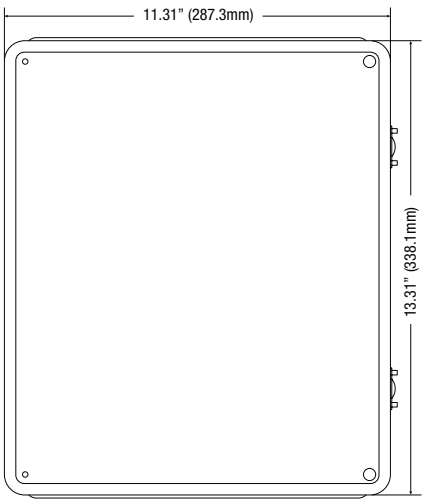

RIGHT SIDE VIEW

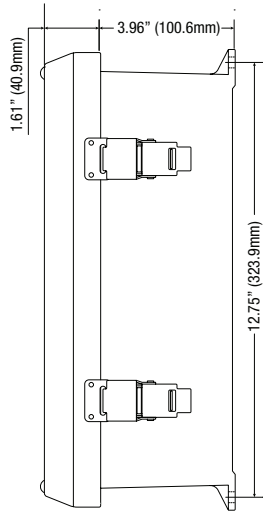

FRONT VIEW COVER REMOVED

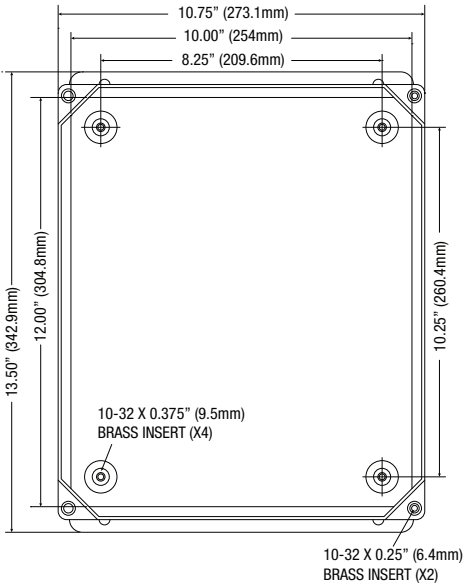

END VIEW

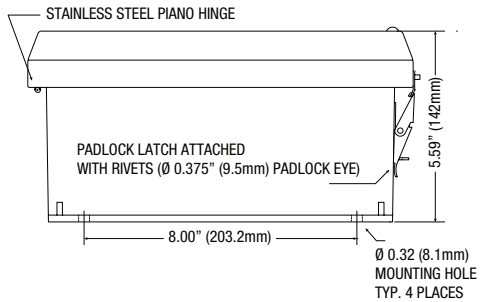

Altronix is not responsible for any typographical errors.

140 58th Street, Brooklyn, New York 11220 USA | phone: 718-567-8181 | fax: 718-567-9056
website: www.altronix.com | e-mail: info@altronix.com | Lifetime Warranty
IIWayPoint102 109U

