

TR²IVE™

Access & Power Integration

Trove1BL1R

- Trove rack enclosure with universal blank backplane (TBL1R)

Installation Guide



More than just power.™

All registered trademarks are property of their respective owners.

Rev. TBLR102418

Installing Company: _____ Service Rep. Name: _____

Address: _____ Phone #: _____

Overview:

Altronix Trove1BL1R can be customized to accommodate various combinations of access control and power supply boards and accessories for access control systems. TBL1R backplane is blank, which allows for ultimate flexibility in configuration.

Specifications:

Agency Listings:

- CE European Conformity.

Trove1BL1R

Trove1R rack mount enclosure with TBL1R universal blank backplane.

- Black enclosure with ample knockouts for convenient access.
- Includes: tamper switch, cam lock.
- Modular 2U standard EIA 19" drawer with extendable slides up to 48".
- Dimensions (H x W x D): 3.25" x 19.0" x 26.5" (82.6mm x 482.6mm x 673.1mm).

TBL1R

Universal blank backplane.

- 16 Gauge backplane.
- Includes mounting hardware.
- Dimensions (H x W x D): 18.5" x 15.25" x 0.05" (469.9mm x 387.4mm x 1.3mm).

Optional Accessories:

- *RE2*: Rack Mount Battery Enclosure accommodates up to four (4) 12VDC/7AH batteries
- *WM5, WM25, WM100*: Magnetic Cable Tie Mounts (5, 25, 100 counts).
- *LC3*: 6 ft. three-wire line cord.

Assembling and Attaching Z Bracket Wire Management Accessory (included):

Altronix Trove Rack enclosures include Z Bracket, a convenient and reliable wire management accessory.

Hardware (included):

 Ten (10) bolts and  eight (8) lock nuts.

1. Carefully unpack Z Bracket. Do not discard hardware (included) (*Fig. 1, pg. 2*).
2. Attach arms to each other using bolts and lock nuts (*Fig. 1a, pg. 2*).
3. Attach the hinge brackets to the ends of arms using bolts and nuts positioning them as shown on *Fig. 1b, pg. 2*.
4. Make sure that all nuts are tightened.

Fig. 1a

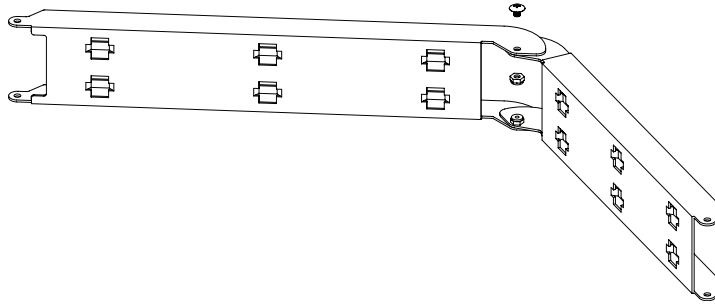

Fig. 1

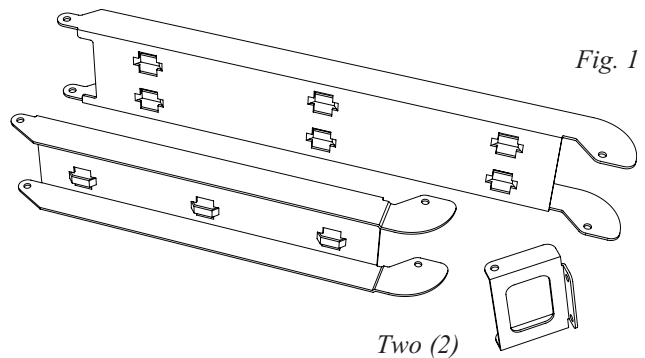
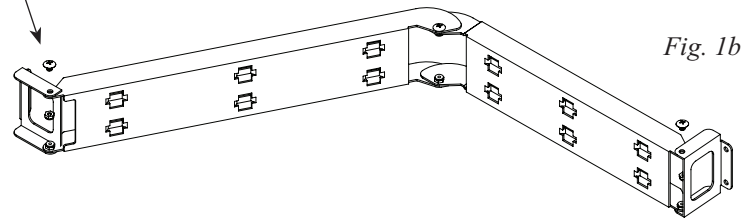

Fig. 1b



5. Attach the hinge bracket on the longer side of Z Bracket to the adjustable slide using bolts and lock nuts (included) (*Fig. 2, 2a, pg. 2*).
6. Attach the hinge bracket on the shorter side of Z Bracket to the rear of the rack enclosure using bolts (included).

Fig. 2

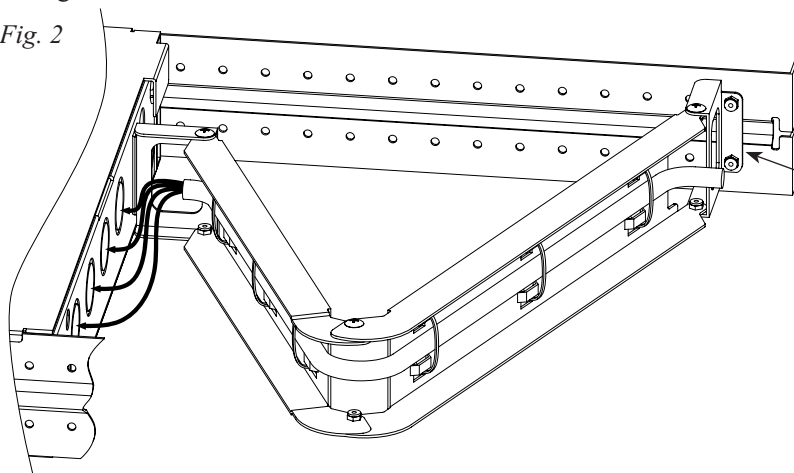

Fig. 2a

Installation Instructions for Trove1R:

Wiring methods shall be in accordance with the National Electrical Code/NFPA 70/ANSI, and with all local codes and authorities having jurisdiction. Product is intended for indoor use only.

1. Remove backplane from enclosure prior to installing into rack cabinet (do not discard hardware).
2. In order to mount included UL Listed tamper switch (Altronix Model TS112 or equivalent) turn the enclosure upside down. Punch out the knockout in designated location, on the back of the unit, from outside of the drawer (*Fig. 3, pg. 3*). Insert the tamper switch into the knockout from outside of the drawer with the button facing outwards and spaded connectors inside the drawer. Connect tamper switch wiring to the Access Control Panel input or the appropriate UL Listed reporting device. To activate alarm signal open the rack drawer.
3. Slide the Trove rack enclosure into an open 2U location in the rack cabinet.
4. Utilizing proper fasteners attach front ears to the rack rails.
5. Attach the rear of the adjustable slides to the rear rails of the rack cabinet with the proper fasteners.
6. **Mounting Boards and Accessories to TBL1R:**
 - a. Carefully plan the boards' layout and mark their place(s) on backplane.
 - b. Drill the backplane in the marked spots using appropriate tools.
 - c. Attach mounting hardware for the boards and mount boards according to their specifications.
 - d. Make all wire connections between boards prior to mounting backplane into Trove rack.
 - e. Ensure all internal configurations (voltage selection, switch settings, etc.) are completed before mounting backplane back into Trove rack enclosure.
7. After all components are mounted on the backplane, fasten backplane into Trove rack utilizing supplied mounting hardware.

Fig. 3 Back of the drawer, viewed from outside.

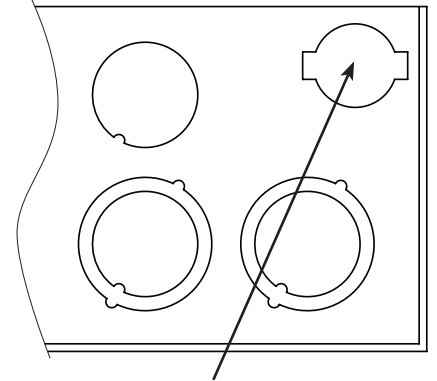

Tamper Switch mounting location

Trove1BL1R Enclosure Dimensions (H x W x D):

3.25" x 19.0" x 26.5" (82.6mm x 482.6mm x 673.1mm). Shown with Z Bracket attached.

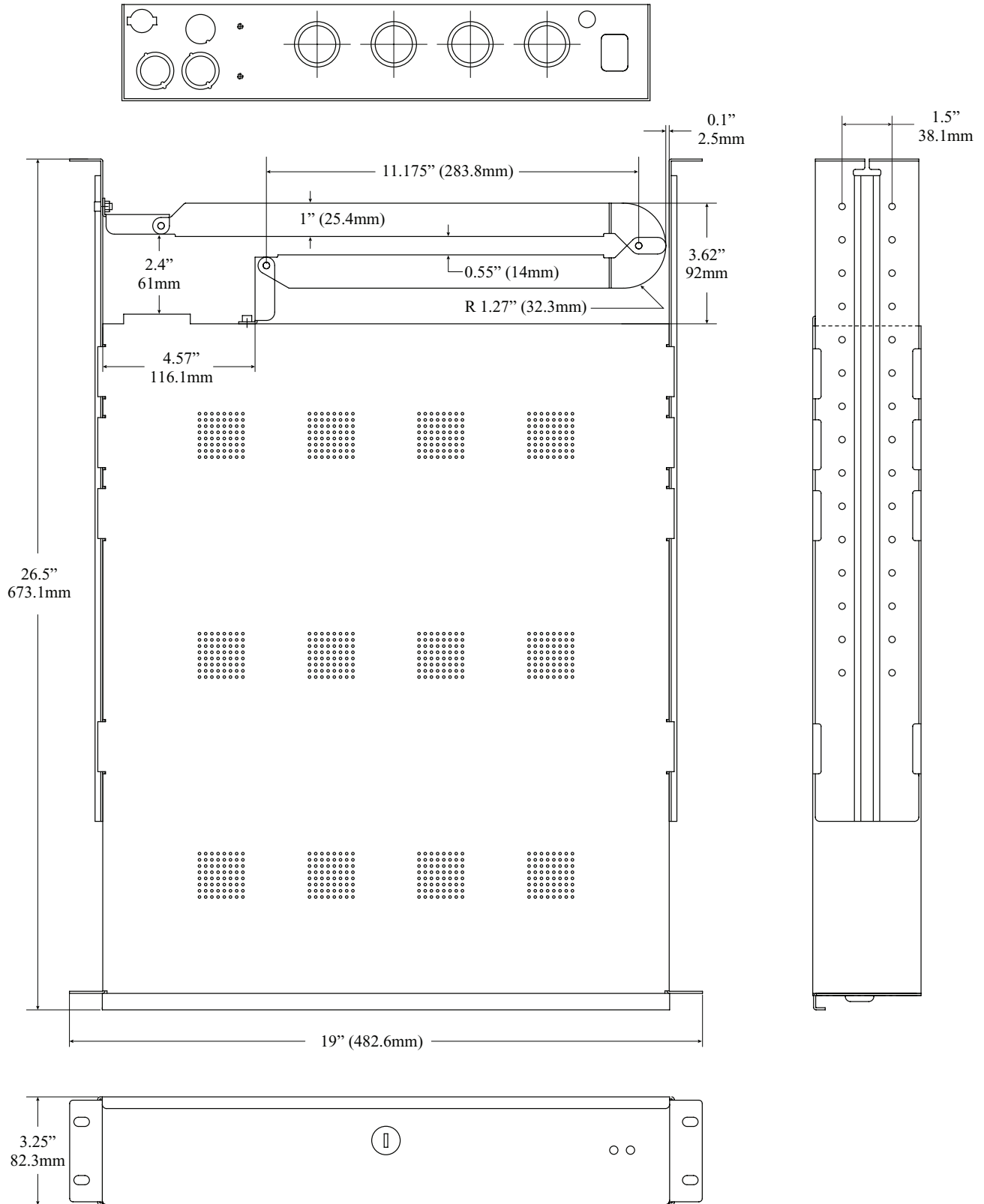

Altronix is not responsible for any typographical errors.

140 58th Street, Brooklyn, New York 11220 USA | phone: 718-567-8181 | fax: 718-567-9056

web site: www.altronix.com | e-mail: info@altronix.com | Made in U.S.A.

ITrove1BL1R

L11R

